

# RD132 Disc Mower-Conditioner Header

## Repair Manual

87755424 1/08  
1st Printing

**CASE *III***

# **RD132 REPAIR MANUAL CONTENTS**

- SECTION 00 - GENERAL INFORMATION**
- SECTION 35 - HYDRAULICS**
- SECTION 58 - ATTACHMENTS/HEADERS**
- SECTION 88 - OPTIONAL EQUIPMENT**
- SECTION 90 - DECALS**

**The sections used through out all Case IH product Repair manuals may not be used for each product. Each Repair manual will be made up of one or several books.**

**The sections listed above are the sections utilized for the RD132 Disc Mower-Conditioner Header.**

---

# COMPLETE CONTENTS

## SECTION 00 - GENERAL INFORMATION

### Chapter 1 - General Information

#### CONTENTS

<b>Section</b>	<b>Description</b>	<b>Page</b>
	Forward .....	2
	Precautionary Statements .....	3
	Safety .....	4
	Introduction .....	5
	Theory of Operation .....	6
	Roll Conditioning .....	6
	Roll Gap .....	6
	Roll Tension .....	6
	Torsion Bar Tensioning System .....	7
	Properly Conditioned Crop .....	7
	Checking Crop .....	7
	Product Identification Number .....	8
	Jack Assembly .....	8
	Shielding .....	8
	Storing the Header .....	9
	Specifications .....	10
	Special Tools .....	10
	Hardware Torque Values .....	11
	Minimum Hardware Tightening Torques .....	12
	Installation of Adjustable Fittings in Straight Thread O-ring Bosses .....	14
	Standard Torque Data For Hydraulic Tubes and Fittings .....	14
	Pipe Thread Fitting Torque .....	15
	Installation of ORFS (O-ring Flat Faced) Fittings .....	15
	Recommended Sealants .....	16
	Sealants .....	16
	Ecology and the Environment .....	17
	Universal Symbols .....	18

**<https://www.ebooklibonline.com>**

Hello dear friend!

Thank you very much for reading.

Enter the link into your browser.

The full manual is available for immediate download.

**<https://www.ebooklibonline.com>**

---

## SECTION 00 - GENERAL INFORMATION

### Chapter 2 - Adjustments

#### CONTENTS

Section	Description	Page
	Description and Operation .....	2
	Swathing .....	2
	Conditioner Roll Gap .....	3
	Conditioner Roll Pressure .....	4
	Unplugging the Conditioner Rolls .....	5
	Roll Timing - Rubber Rolls .....	6
	Conditioner Belt .....	7
	Cutting Height .....	7
	Header Speed Sensor Adjustment .....	8

## SECTION 00 - GENERAL INFORMATION

### Chapter 3 - Troubleshooting

#### CONTENTS

Section	Description	Page
	Troubleshooting .....	2

---

## SECTION 35 - HYDRAULICS

### Chapter 1 - Header Drive Motors - RD132

#### CONTENTS

<b>Section</b>	<b>Description</b>	<b>Page</b>
	Description of Operation .....	2
	Hydraulic Motors .....	2
	Overview .....	3
	Special Tools .....	3
	Specifications .....	3
	Fixed Displacement Motors .....	3
	Lubrication .....	3
	Overhaul .....	5
	Hydraulic Motor .....	5
	Removal .....	5
	Inspection .....	5
	Installation .....	6
	Back Plate .....	7
	Disassembly .....	7
	Inspection .....	8
	Assembly .....	9
	Main Shaft .....	11
	Removal .....	11
	Inspection .....	15
	Assembly .....	16
	Troubleshooting .....	21
	Labor Guide .....	22

---

## SECTION 58 - ATTACHMENTS/HEADERS

### Chapter 1 - Bevel Gearbox Header Drive

#### CONTENTS

Section	Description	Page
	Introduction .....	2
	Overhaul .....	2
	Bevel Gearbox .....	2
	Removal .....	2
	Disassembly .....	5
	Upper Bearing .....	7
	Removal .....	7
	Installation .....	7
	Lower Bearing .....	8
	Removal .....	8
	Installation .....	8
	Vertical Shaft (Gearbox) .....	9
	Assembly .....	9
	Side Shaft .....	10
	Assembly .....	10
	Installation .....	11
	Labor Guide .....	15

---

## SECTION 58 - ATTACHMENTS/HEADERS

### Chapter 2 - Cutter Bar

#### CONTENTS

Section	Description	Page
	Introduction .....	2
	Discs .....	5
	Knife and Bolt Inspection .....	6
	Disc Knives .....	7
	7 Degree Twist Knives .....	7
	14 Degree Twist Knives .....	7
	14 Degrees Serrated Knives .....	7
	V Knives .....	7
	Overhaul .....	8
	Knife Replacement .....	8
	Crop Lifter Replacement .....	10
	Rock Guards .....	11
	Skid Shoes .....	11
	Cutter Bar Inspection/Failure Analysis .....	12
	Top Cap .....	15
	Removal .....	15
	Inspection .....	16
	Installation .....	16
	Cutter Bar .....	19
	Removal .....	19
	Installation .....	22
	Bayonet Bushing - Replacement .....	23
	Disassembly .....	24
	Reassembly .....	25
	Shear Hub .....	29
	Removal .....	29
	Installation .....	30
	Inspection .....	31
	Disc Module .....	32
	Disassembly .....	32
	Assembly .....	34
	Cutter Bar Drive Shaft .....	38
	Removal .....	38
	Disassembly .....	39
	Assembly .....	41

---

## SECTION 58 - ATTACHMENTS/HEADERS

### Chapter 3 - Conditioner Rolls Drive System

#### CONTENTS

Section	Description	Page
	Introduction .....	2
	Conditioner Belt .....	2
	Belt Adjustment .....	3
	Overhaul .....	4
	Conditioner Belt .....	4
	Belt Replacement .....	4
	Conditioner Roll Gearbox .....	7
	Removal .....	7
	Disassembly .....	9
	Assembly .....	10
	Installation .....	11

## SECTION 58 - ATTACHMENTS/HEADERS

### Chapter 4 - Conditioner Rolls and Drive Shafts

#### CONTENTS

Section	Description	Page
	Introduction .....	2
	Overhaul .....	2
	Conditioner Roll Drive Shaft .....	2
	Removal .....	2
	Disassembly .....	3
	Assembly .....	5
	Installation .....	6
	Lower Conditioner Roll .....	7
	Removal .....	7
	Installation .....	10
	Upper Conditioner Roll .....	13
	Removal .....	13
	Installation .....	16

---

## SECTION 58 - ATTACHMENTS/HEADERS

### Chapter 5 - Conditioner Roll Tension System

#### CONTENTS

Section	Description	Page
	Theory of Operation .....	2
	Roll Conditioning .....	2
	Roll Gap .....	2
	Roll Tension .....	2
	Torsion Bar Tensioning System .....	2
	Properly Conditioned Crop .....	3
	Checking Crop .....	3
	Rolls in Home Position .....	4
	Rolls Open at 15 Degrees .....	4
	Rolls Fully Open at 27.3 Degrees .....	4
	Disassembly .....	5
	Assembly .....	9

## SECTION 88 - OPTIONAL EQUIPMENT

### Chapter 1 - Optional Equipment

#### CONTENTS

Section	Description	Page
88 000	Optional Equipment .....	2
	Field Installed Options .....	2
	High Stubble Kit .....	2
	Rolling Crop Dividers .....	3
	Pushbar and Dividers .....	3
	Corner Marker .....	4

---

**SECTION 90 - DECALS**

**Chapter 1 - Decals**

**CONTENTS**

<b>Section</b>	<b>Description</b>	<b>Page</b>
	Safety Decals .....	2

## SECTION 00 - GENERAL INFORMATION

### Chapter 1 - General Information

#### CONTENTS

Section	Description	Page
	Forward .....	2
	Precautionary Statements .....	3
	Safety .....	4
	Introduction .....	5
	Theory of Operation .....	6
	Roll Conditioning .....	6
	Roll Gap .....	6
	Roll Tension .....	6
	Torsion Bar Tensioning System .....	7
	Properly Conditioned Crop .....	7
	Checking Crop .....	7
	Product Identification Number .....	8
	Jack Assembly .....	8
	Shielding .....	8
	Storing the Header .....	9
	Specifications .....	10
	Special Tools .....	10
	Hardware Torque Values .....	11
	Minimum Hardware Tightening Torques .....	12
	Installation of Adjustable Fittings in Straight Thread O-ring Bosses .....	14
	Standard Torque Data For Hydraulic Tubes and Fittings .....	14
	Pipe Thread Fitting Torque .....	15
	Installation of ORFS (O-ring Flat Faced) Fittings .....	15
	Recommended Sealants .....	16
	Sealants .....	16
	Ecology and the Environment .....	17
	Universal Symbols .....	18

## **FOREWORD**

Appropriate service methods and correct repair procedures are essential for the safe, reliable operation of all equipment, as well as the personal safety of the individual performing the repair.

This Repair Manual provides troubleshooting and overhaul instructions using recommended procedures and equipment. Following these instructions will ensure the safe, efficient, and timely completion of the service or repair.

The manual is divided into sections which are subdivided into chapters. Each chapter contains information on general operating principals, detailed inspection, overhaul and, where applicable, specific troubleshooting, special tools, and specifications.

Any reference in this manual to right, left, rear, front, top, or bottom is determined by standing behind the machine and looking in the direction of travel.

All data and illustrations in this manual are subject to variations in build specification. This information was correct at the time of issue, but Case IH policy is one of continuous improvement, and the right to change specifications, equipment, or design at any time, without notice, is reserved.

# PRECAUTIONARY STATEMENTS

## PERSONAL SAFETY

Throughout this manual and on machine decals, you will find precautionary statements (“**DANGER**”, “**WARNING**”, and “**CAUTION**”) followed by specific instructions. These precautions are intended for the personal safety of you and those working with you. Please take the time to read them.



**DANGER**



This word “**DANGER**” indicates an immediate hazardous situation that, if not avoided, will result in death or serious injury. The color associated with Danger is RED.

---



**WARNING**



This word “**WARNING**” indicates a potentially hazardous situation that, if not avoided, could result in death or serious injury. The color associated with Warning is ORANGE.

---



**CAUTION**



This word “**CAUTION**” indicates a potentially hazardous situation that, if not avoided, may result in minor or moderate injury. It may also be used to alert against unsafe practices. The color associated with Caution is YELLOW.

---

**FAILURE TO FOLLOW THE “DANGER”, “WARNING”, AND “CAUTION” INSTRUCTIONS MAY RESULT IN SERIOUS BODILY INJURY OR DEATH.**

## MACHINE SAFETY

The precautionary statement (“**IMPORTANT**”) is followed by specific instructions. This statement is intended for machine safety.

**IMPORTANT:** *The word “IMPORTANT” is used to inform the reader of something he needs to know to prevent minor machine damage if a certain procedure is not followed.*

## INFORMATION

**NOTE:** *Instructions used to identify and present supplementary information.*

# SAFETY

## PRECAUTIONARY STATEMENTS

A careful operator is the best operator. Most accidents can be avoided by observing certain precautions. To help prevent accidents, read the following precautions before operating this equipment. Equipment should be operated only by those who are responsible and instructed to do so.

Carefully review the procedures given in this manual with all operators. It is important that all operators be familiar with and follow safety precautions.

1. **Do not operate the disc header without all the cutter bar shields down, cover skirts installed and in good condition, and cover skirts snapped together. Immediately replace any skirt that is torn or has a hole in it.**
2. **Header locks are built into the header lift system to lock the header in the raised position. Lock the header on both sides before working under a raised header.**
3. **Use the amber flashing safety lights and road lights when driving the self-propelled windrower and header on the highway. Be sure to use the road lights, not the work lights, because the rear work lights could be mistaken for the headlights of an oncoming vehicle.**
4. **Instruct inexperienced operators to read the operator's manual, safety signs, and become familiar with the handling of the unit which the disc header is attached. Operate the unit in uncongested areas where there is no likelihood of personal injury or property damage.**
5. **Never make any adjustments or attempt to work on the unit with the engine running. Disengage the header drive, lower the header to the ground, or lock it in the transport position, shut off the engine, and engage the parking brake before attempting any adjustments or trying to work on the header.**
6. **Tilt the cutter bar back in fields where stones and foreign objects are present, to raise the cutting knives, minimize debris deflected from the knives and reduce knife damage.**
7. **Do not attempt to remove material from the disc header while it is in operation. Shut the windrower off and allow the rotating discs to stop before leaving the windrower cab. Rotating elements may cause serious bodily injury.**
8. **Always operate the disc header with the covers and shields in place. Do not lean against or stand on the covers or shields.**
9. **Do not attempt to adjust the lift linkage with a header attached. Header will drop suddenly if clevis pin is driven out, causing header damage and/or personal injury.**
10. **Observe the following precautions before adjusting or lubricating the header.**
  - **Disengage the header drive.**
  - **Lower the header to the ground, or raise the header and engage the header locks.**
  - **Stop the engine and engage the parking brake before leaving the cab.**
  - **Reinstall and close all shielding before operating the unit.**
11. **Do not attempt to clean, lubricate, or adjust the machine while it is running.**
12. **Replace damaged knives, knife hardware or discs immediately to prevent an accident.**
13. **The bottom leading edge of worn discs can become very sharp. Wear gloves to prevent injury.**
14. **Do not weld on wheels. Welding on wheels may cause high stress and a wheel failure.**
15. **Do not weld on wheels with a mounted tire. Welding on wheels with a mounted tire may cause the tire to burst, causing serious injury or death.**

## INTRODUCTION

The RD132 disc header is a disc mower-conditioner designed to be used with the WDX1701 (with modification to the tractor and header), WDX1902, WDX2302, WD1903 and WD2303 self-propelled windrower. The two operate together as an integral unit. The valves and cylinders for lifting and tilting the header are mounted on the windrower, as are all the hydraulic controls. The flotation springs or hydraulic lift cylinders are also mounted on the windrower.

The header contains 10 disc mowing modules. A hydraulic pump on the windrower supplies all power for the header.

The windrower controls the speed of the header in either automatic or manual mode. In the automatic mode, the speed is held constant regardless of the speed of the windrower. In the manual mode, the speed varies with the windrower engine speed. The mode is set from the windrower cab.

**NOTE:** *On this equipment, left and right are determined by standing behind the unit, looking in the direction of travel.*

## THEORY OF OPERATION

### ROLL CONDITIONING

Roll conditioning passes the cut crop through a set of closely spaced intermeshing rolls with matching lands and valleys. The rolls crush and crack the plant stem at several points along its length, which wears away the waxy coating and allows moisture to escape.

There are two rolls in roll conditioning.

The lower roll is fixed in the machine.

The upper roll can pivot to let the crop mat feed through the rolls without plugging.

Roll gap and roll tension affect crop conditioning.

See below for more information.

### Roll Gap

The roll gap is the space between the land of one roll and valley of the opposite conditioning roll. This space should be kept between 0.4 mm - 3 mm (1/64 in. - 1/8 in.) to provide the best performance.

To check the roll gap easily and quickly in the field, use the "one stem method". Take one stem of the crop being cut and pass it between the rolls at three or four points across the roll width. The stem should move between the rolls, but with some resistance. If the stem passes through the gap with little or no resistance, the gap should be reset closer. If you cannot pass the stem between the rolls at all, the gap should be increased slightly. To get peak machine performance and efficiency, check the roll gap before each cutting during the season, and also when cutting different forage crops because each crop will be different.

In high volume crops like Sudan grass and other cane-type crops, increase the roll gap slightly to get better crop flow through the rolls without sacrificing good crop conditioning. The lands and valleys should be centered to maintain a uniform distance on all sides of the lands.

### Roll Tension

After setting the roll gap, adjust the roll tension. Roll tension is the amount of pressure added to restrict upper roll movement as the crop feeds through the rolls. Hard-to-condition crops require more tension. Light and easily-conditioned crops require less tension. Higher roll tensions increase the pressure exerted on the crop mat as it moves between the lands and valleys, increasing the ability of the rolls to crack and wear the stem away. Higher roll tensions result in more aggressive crop conditioning because the rolls become more resistant to spreading apart as the crop is fed through.

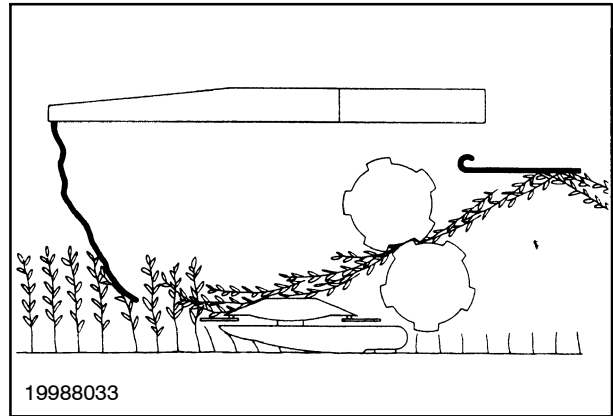

1

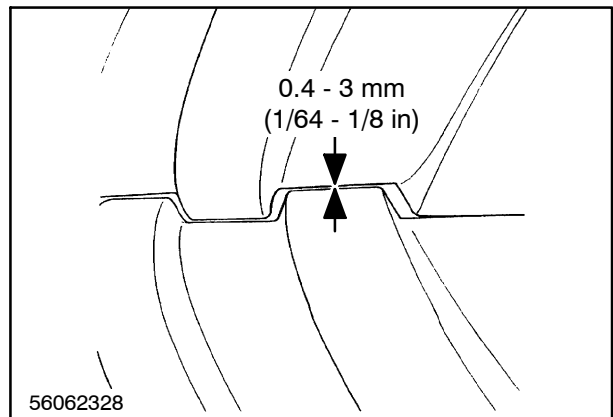

2

### **Torsion Bar Tensioning System**

The torsion bar tensioning system maintains uniform pressure throughout the range of roll movement as the crop mat passes through, providing better control and reducing potential crop plugging. In most conditions, a good starting point for tension on intermeshing rolls is to increase the roll tension by turning the adjusting crank 8 full turns after you start to feel resistance on the crank handle.

Too large a roll gap or too little roll tension under-conditions the crop, resulting in extended dry down times and increased potential for weather-related damage. Too close a roll gap or too much roll tension can severely over-condition the crop, breaking the tops away from the plants and causing excessive leaf loss. It can also cause excessive wear of the conditioning rolls if they touch while turning.

### **Properly Conditioned Crop**

Properly conditioned crops will show a pattern of cracks at regular intervals along the plant stem. Each

crack will be about 25-50 mm (1-2 in.) in length. The stem should look flat in these cracked areas. Depending on crop height when cut, there will be at least two or three cracks along the plant length. The plant leaves should show only minimal bruising. Leaf bruising is characterized by dark green streaks or marks across the leaf surface. While some leaf bruising can't be avoided, too much bruising is not good because the bruises allow moisture to escape the leaf. When this occurs, the leaf dries too quickly, resulting in loss of the plant leaf before or during packaging. This in turn reduces the overall feed value of the crop.

### **Checking Crop**

As a general check, grab a handful of crop directly behind the machine after it has been processed and hold it in one hand. The plant stems should be fairly limp and just fold over your hand. Nine out of 10 stems in a random sample should show stem cracks. Inspect the leaves in the same random sample, and no more than 5% of the leaves should have bruising.



**Suggest:**

**For more complete manuals. Please go to the home page.**

**<https://www.ebooklibonline.com>**

**If the above button click is invalid. Please download this document first, and then click the above link to download the complete manual.**

**Thank you so much for reading**

**PRODUCT IDENTIFICATION NUMBER**

The product identification number plate, 1, for the disc mower-conditioner is located at the back on the left side of the frame.

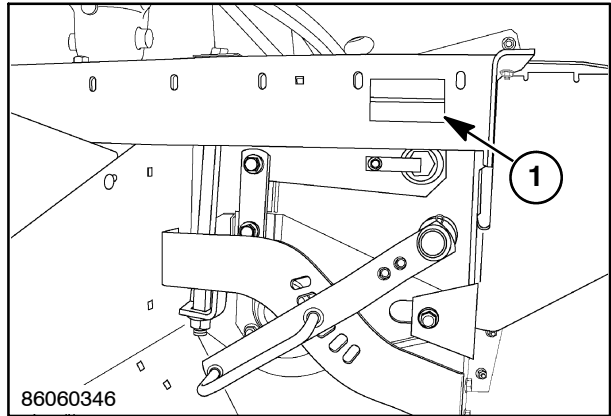

3

**JACK ASSEMBLY**

There is one jack stand on the header, 1, located on the left side of the unit.

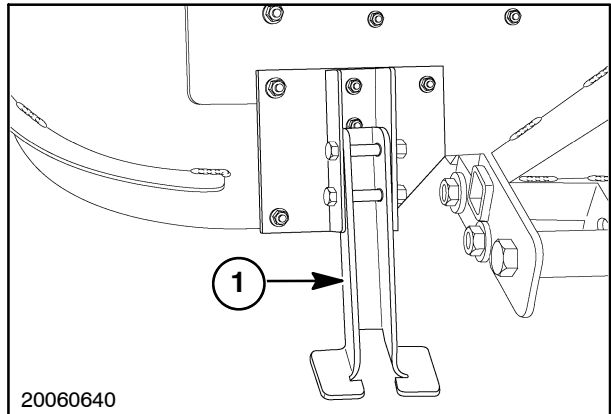

4

**SHIELDING**

**NOTE:** Before raising either of the front shields, unhook the cutter bar shield skirt spring snaps, 1, at the skirt overlaps. Be sure that the skirts are reattached before using the header again.

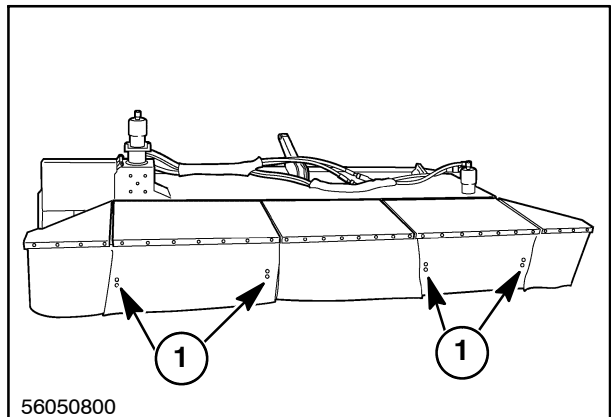

5

When raised, the front shields are held in place by a lever, 1. The lever automatically springs into the lock as the shield is raised. To lower the shield, release the lever by pushing it to the side.

**⚠ WARNING ⚠**

**Close shields prior to operating the machine to prevent damage to the shield. Running the header with a damaged shield may result in bodily injury from flying objects. Failure to comply could result in death or serious injury.**

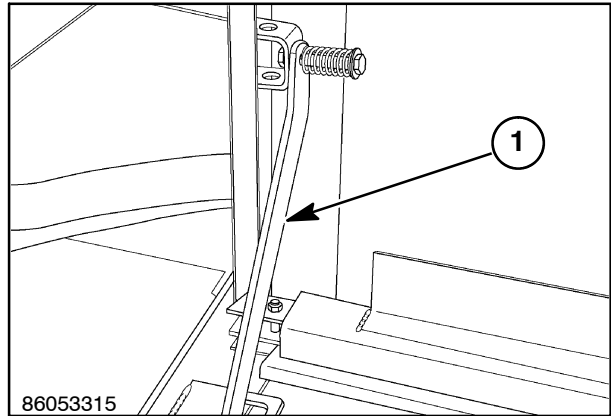

6

### STORING THE HEADER

When preparing the header for storage:

1. Clean the header thoroughly. Remove any build-up of debris and any wrapped material from the cutter bar and the conditioner rolls.
2. Lubricate the header.
3. Drain the oil from all gearboxes and refill with clean oil of the correct specification to the correct level. Run the header for a few minutes.
4. Inspect for worn or broken parts. Replace with genuine factory parts.
5. Relieve roll pressure.
6. Remove tension from the roll drive belt.
7. Clean rusted or abraded areas and touch up with factory paint. Spray cans are available from your authorized dealer.
8. Store the header where it is not exposed to weather.

**<https://www.ebooklibonline.com>**

Hello dear friend!

Thank you very much for reading.

Enter the link into your browser.

The full manual is available for immediate download.

**<https://www.ebooklibonline.com>**