

RBX341 Silage Pack

Repair Manual

6- 33700



REPAIR MANUAL

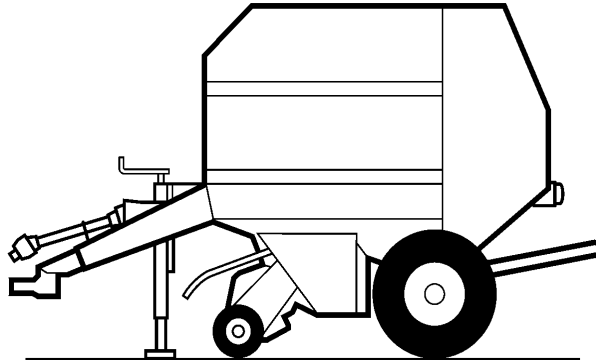

RBX341 ROUND BALER

SECTIONS

GENERAL INFORMATION	1000
ELECTRICAL SYSTEM	4000
IMPLEMENT POWER TAKE-OFF	6000
BRAKES	7000
PRODUCT FEEDING	6000
HYDRAULIC SYSTEMS	8000
CHASSIS COMPONENTS	9000
FAULT FINDING	10000

S E R V I C E

RBX341 BALER AND RBX341 SILAGE PACK

SERVICE MANUAL

TABLE OF CONTENTS BINDER 1 CONTAINS TABS 1, 4, 6, 7, 8, 9, AND 10

1. GENERAL INFORMATION - BALER ONLY

Section	Description	Page
1001	Introduction,	2
	Important Information,	2
	General Instruction,	3
	Spare Parts,	4
	Safety Regulations,	5
	Product Identification	8

1. TECHNICAL INFORMATION - BALER ONLY

Section	Description	Page
1002	Driveline Schematic,	3
	Drive Line Schematic,	4
	Conversion Chart,	6
	Tightening Torques,	7
	Lubricants To Be Used,	8
	Specifications,	8
	Dimensions,	9
	Technical Data,	10
	Hauling The Baler,	17
	Low Hitch,	17
	High Hitch,	18

1. TECHNICAL INFORMATION - BALER WRAPPER

Section	Description	Page
1002.1	Specifications	1
	Torque Values	5
	General Information	7

<https://www.ebooklibonline.com>

Hello dear friend!

Thank you very much for reading.

Enter the link into your browser.

The full manual is available for immediate download.

<https://www.ebooklibonline.com>

4. ELECTRICAL SYSTEM - BALER ONLY

Section	Description	Page
4001	Set-up And Diagnostics,	2
	Bale Density Sensors Mounting,	3
	Sensor And Actuator Disassembly/Assembly ,	10
	Twine Actuator Sensor (Page 19 On The Set-up/Diagnostic Mode),	16
	Rotor cutter Actuator Sensor (Page 14 In The Set-up/Diagnostic Mode),	21
	Assembly,	22
	Tailgate Switches (Page 15 Of The Set-up/Diagnostic Mode),	28
	Net Metering Roll Sensor (Page 16 Of The Set-up/Diagnostic Mode) ,	30
	Bale Shape Sensitivity (Page 17 Of The Set-up/Diagnostic Mode) ,	32
	Software Revision Number (Page 18 Of The Set-up/Diagnostic Mode),	33
	Operator Panel Test (Page 19 Of The Set-up/Diagnostic Mode),	34
	Keypad Check,	35
	Supply Voltage Check (Page 20 Of The Set-up/Diagnostic Mode),	37
	To Deactivate The Twine Wrap,	40
	Wiring Diagram,	41
	Rotor cutter Wiring Diagram,	44
	Serviceable Operator Panel Components,	45
	Serviceable Controller Components,	46
	Harness Connector Repair,	47
	Troubleshooting,	50
	Twine/Net Actuator Test Procedure,	57
	Dealer Pre Delivery Set-up,	58

4. ELECTRICAL SYSTEM - BALER WRAPPER

Section	Description	Page
4001.1	Specifications	1
	Tooling	2
	Wrapper Control Module and sensors	5
	Description and Operation	9
	Schematics	15
	Fault Finding and Error Codes	53
	Connector Repair	207

6. POWER TAKE OFF CLUTCH - BALER ONLY

Section	Description	Page
6001	Cut Out Clutch,	1
	Clutch Removal,	3
	Clutch Assembly,	5

6. POWER TAKE OFF - GEARBOX - BALER ONLY

Section	Description	Page
6002	Gearbox (US),	1
	Removal,	5
	Reinstallation,	13
	Gearbox (Comer),	6
	Front Pinion Disassembly And Check,	12
	Main Gearbox Disassembly,	16
	Main Gearbox Assembly,	18
	Gearbox Installation,	21

6. PRODUCT FEEDING - PICK UP - BALER ONLY

Section	Description	Page
6003	Pick Up Removal And Installation,	1
	Installation,	2
	Cam Track Replacement,	3
	Assembly,	4
	Pick-up Reel,	5
	Reel Drive (Left-hand Side),	7
	Reel Drive (Right-hand Side),	9
	Standard Pick-up,	11
	Cam Track Disassembly,	13
	Cam Track Assembly,	15
	Cam Track Roll Disassembly And Assembly,	18
	Pick-up Tine Replacement,	20

6. PRODUCT FEEDING - ROTOR MODULE - BALER ONLY

Section	Description	Page
6004	Cross Drive Shaft (Wide Pick-up Units),	1
	Intermediate Shaft,	3
	Overrun Clutch,	3
	Rotor Bearings,	5
	Rotor And Scrapers,	8
	Rotor Scrapers,	9
	Rotor,	10
	Stub Augers,	13
	Rotor Cutter System,	15

6. PRODUCT FEEDING - CONVEYOR CHAIN - BALER ONLY

Section	Description	Page
6005	Replacing A Roller Bearing / Conveyor Bar,	1
	Chain Removal,	4
	Chain Installation,	6
	Chain Replacement,	10
	Conveyor Chain Drive Shaft,	12
	Conveyor Chain Lower Top Idlers,	14
	Lower Idler Shaft,	15
	Conveyor Chain Tensioner Shaft,	17

6. PRODUCT FEEDING - ROLLS GROUP - BALER ONLY

Section	Description	Page
6006	Floor Roll,	1
	Installation,	2
	Bearing Replacement,	3
	Stripper Roll,	4
	Assembly,	4

6. PRODUCT FEEDING - NET/TWINE WRAP SYSTEM - BALER ONLY

Section	Description	Page
6007	Twine Wrapper,	1, 8
	Net - Plastic Wrap System (Duckbill),	3
	Replacement Of The Spreader Roll Bearings,	5
	Duckbill Reassembly,	6
	Replacement Of The Counter Roll Bearings,	6
	Chain Disassembly,	9
	Driven Pinion, Disassembly-assembly,	10
	Drive Pinion And Drive Mechanism Disassembly-assembly,	13
	Drive Pinion,	15
	Twine Feed Roller disassembly-assembly,	16
	Twine Spreader Hook disassembly-assembly,	15
	Wrapper Unit Assembly,	19

7. BRAKES - BALER WRAPPER

Section	Description	Page
7001	Technical data	1
	Park brake	2
	Hydraulic brake system	3
	Brakes shoes	4
	Air brake Description of operation	8
	Air brake valve	10

8. HYDRAULIC SYSTEM - CYLINDERS AND ROLLERS - BALER ONLY

Section	Description	Page
8001	Pick-up Lift Cylinder	1
	Cylinder Seal Kit Replacement,	2
	Lock-out Valve Replacement,	3
	Tailgate Lift Cylinders,	3
	Checking Cylinder Characteristics,	5
	Density Cylinders,	5
	Checking The Oil And Accumulator Pressure,	9
	Accumulator Filling,	10
	Cylinder Seal Kit Replacement	11
	Cylinder Filling,	13
	Automatic Oiler,	14
	Greasing Lines And Metering Units,	15

8. HYDRAULIC SYSTEM - BALER WRAPPER

Section	Description	Page
8001.1	Specifications	1
	Tightening Torques	1
	Tools	1
	Description of Hydraulic Circuit	10
	Description of Hydraulic Wrapping Process	12
	Fault Finding	45
	Overhaul	55

9. CHASSIS COMPONENTS - BALER WRAPPER

Section	Description	Page
9001	Baler wrapper components	1
	Satellite Assembly	2
	Satellite motor and brake valve	4
	Film dispensers	6
	Bale lift fork assembly	8
	Table assembly	10

9. AXLES - BALER WRAPPER

Section	Description	Page
9001.1	Specifications	1
	Axle assembly	1
	Tire and Wheel	3
	Wheel Hub and Bearing	4

10. FAULT FINDING - BALER ONLY

Section	Description	Page
10001	P.T.O. Drive Area,	1
	Pick-up Area,	1, 2
	Bale Formation,	3
	Bale Density,	3, 4
	Twine Wrapping,	4
	Automatic Lubrication ,	11
	Baler Performance Monitor System,	12
	Rotor cutter,	10, 20

10. FAULT FINDING - BALER WRAPPER

Section	Description	Page
10001.1	Electrical Fault Finding (also refer to Section 4001 Electrical System)	2
	Hydraulic Fault Finding (also refer to Section 8001 Hydraulic System)	18
	Satellite Calibration	21

Section 1002.1

1002

GENERAL INFORMATION RBX341 Round Baler Wrapper

1002.1-1 GENERAL INFORMATION

BALER WRAPPER

CONTENT

Section	Description	Page
1002.1	Specifications	1
	Torque Values	5
	General Information	7

SPECIFICATIONS

Baler wrapper	Specifications
Technical data	
Total length	6.28 m (20.6 ft)
Total width (standard tyres)	2.79 m (9.2 ft)
Total width (optional tyres)	2.99 m (9.8 ft)
Total height	2.83 m (9.3 ft)
Wheel spacing (standard)	2.35 m (7.7 ft)
Wheel spacing (optional tyres)	2.45 m (8.0 ft)
Weight	
Total weight (less bale, net and film). Standard tyres, hydraulic brakes.	4580 kg (10,076 lbs)
Brakes	
Service brake (standard)	Hydraulic. Drum, on 4 wheels
Service brake (option)	Pneumatic. Drum, on 4 wheels
Parking brake	Spindle – Manual operation
Emergency brake (French market only)	Cable activated when connection with tractor is lost
Wheels and Tyres	
Dimension (standard)	15.0 / 55-17-10pr
Dimension (optional)	19.0 / 45-17-10pr
Pressure	1.75 bar @ 30 KPH – 2.0 bar @ 40 KPH (25.36 PSI @ 18 MPH – 29 PSI @ 25 MPH)
Wheel nuts tightening torque	380 Nm (280 lbs ft)
Hitch	
Type	Adjustable, High/Low
Low	450-550mm (17.1-21.6in)
High	750-1000mm (29.5-39.4)
Maximum road speed	40 km/h (25.0mph) (unless local speed regulations restrict to a lower speed)
Tractor requirements	
Minimum kw/hp	67/90
Recommended kw/hp	82/110

Baler wrapper	Specifications
Hydraulic oil flow requirements (closed centre)	
Oil flow from tractor required	Closed centre with continuous feed
Oil flow: minimum	20 litres/min (5 US GPM)
maximum	30 litres/min (8 US GPM)
Pressure: minimum	150 bar (2175 PSI)
maximum	210 bar (3045 PSI)
Valve (closed centre)	1 single acting valve with free return
Hydraulic oil flow requirements (open centre)	
Oil flow from tractor if "open centre"	Flow not to exceed 50 Litres/min (13 US GPM) or fit an Optional divert valve with continuous feed
Wrapper Hydraulics	
Type	Tractor remote
Oil Filter - disposable	10 micron high pressure
Tractor oil flow indicator (visable from tractor cab)	Coloured range indication (green is ok)
Electro magnetic valves (valveblock, rh side)	5, manual override possibility
Electrical system	
Wrapper control module – Installation	12 volts
Infoview monitor	Connector 1 pin
Work lights (ON when Performance monitor ON OFF when performance monitor OFF)	Connector 7 pin
Beacon Light (ON with performance monitor Off OFF with Infoview ON)	Connector 1 pin
Accessory socket	12 volts
Fuse & Relay Board	
Relays	Work light and beacon operation
Fuse (Beacon light)	10 ampere
Fuse (Wrapper Control module)	15 ampere
Fuse (Work light)	15 ampere
Fuse (Wrapper circuit)	30 ampere
Fuse (In main line to tractor)	80 ampere
Sensors Diagnoses. Error & value information	
B1 & B2	2x Film dispenser empty (no movement)
B3	1x Tailgate (open)
B4	1x Tailgate (closed)
B5	1x Tailgate (locked)
B6	1x Satellite home position (& wrap counting)
B7	1x Satellite speed (& relative position)
B8	1x Bale on transfer fork
B9	1x Transfer fork down
B10 & B11	2x Satellite emergency stop
B5, B7	Sensor type - M12 Flush (max distance 2mm)
B1, B2,	Sensor type - M12 Non flush (max distance 5mm)
B3, B4, B6, B8, B9, B10, B11	Sensor type - M18 Non flush (max distance 10mm)
Bale Transfer	
Transfer fork	Pivoting, cradle-type
Bale guides	Pivoting, half-moon shaped

Baler wrapper	Specifications
Wrapping Table	
Chain&bar type	15 steel tubes (Ø 60,3mm) and 2 chains
Bale positioning	4 inclined cylindrical centring rollers
	Rear stop roller
Rotation speed	Three pre-set levels
Drive	Hydraulic motor and gearbox
Wrapping Satellites	
Number of satellites (film dispensers)	2
Film Storage (active + storage)	2+10 rolls
Film width	750 mm (29.5 in)
Prestretching	67% Fixed
Overlap	50% Fixed
Max. rotation speed (rpm)	30 revs/min (Progressive start & stop)
Drive	Hydraulic motor 100cc and chain
Emergency stop	2 protection bars, hydraulic stop
Bale drop	
Wrapping table	Pivoting
	Ground roller with max. pressure control
Drop support roller	1, steered pivoting
Wrapper Performance monitor controller	
Name	Performance monitor
Type	Multi language, two way communication display
Function menu's	Home, Operating, Intervention, Set-up menu
Operation Choice, (main menu, A/M)	Fully automatic, semi-automatic or fully manual cycle based on three functions
1. Bale exit from baler and transfer to wrapper	Automatic start/manual start
2. Film wrapping	Automatic start/manual start /no film wrapping (hay & straw)
3. Bale drop	Automatic start/manual start
Manual Operation (main menu)	
Knives	Open/close
Baler tailgate & transfer fork	Open/close
Satellite positioning	Forward. Stop at home position
Wrapping table (bale drop)	Up/down
Setting (main menu)	
Number of film layers	2-4-6-8 (number of wraps will be set automatically and shown)
Setting (service menu - machine set-up)	
Wrapping table speed (rpm)	slow (18 rpm), standard (24 rpm), fast (30 rpm)
Number of wraps	Non-standard (partial cover) number of film layers or high number (> 8) possibility
Information	Multilingual text & pictural process information
Alarms	Satellite out of position
	Bale stuck
	Emergency stop
	Tailgate open
	Film end/Film broken

Baler wrapper	Specifications
Alarms	Electro magnetic valves.
Rear auxiliary operation	Possibility with monitor and without (direct hydraulic valve operation)
Audible warning during intervention mode	Buzzer mounted behind fuse relay board

Options	
Rotating beacon	Dealer installed option
53% prestretch gear	Dealer installed option
Hydraulic valve for open centre tractors	Dealer installed option

Lifting and craning points

If attempting to lift the baler wrapper it will be necessary to attach the lifting chains at three points and they are from the tow hitch at x1 and either side of the wrapper frame using the lift points shown for x2.

The chains must be capable of lifting weights twice the weight to be lifted, the baler wrapper weighs: 4580 kg (10,076 lbs) therefore the chains must be capable of lifting 9160 kg (20152 lbs)

Approximate chain lengths required less the lift hooks are:

- x1 chain = 5.6 m (18.37 ft)
- x2 chains = 3.7 m (12.1 ft)

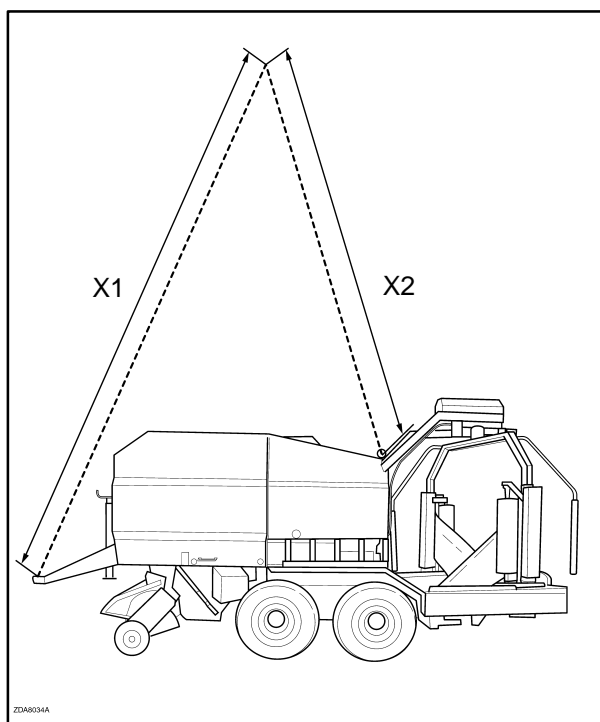

1

TOOLING

Tool or Part	Application	Where used
Tool - for Local manufacture - 28mm Dia	Knife pivot assembly	Bush insertion tool - Section
Tool - for Local manufacture - 60mm Dia	Axle pivot assembly	Bush insertion tool - Section
Electronic Service Tool cable link	Software download	WCM data input - Section

MINIMUM HARDWARE TIGHTENING TORQUES

IN NEWTON-METRES - Nm (FOOT POUNDS - LBF. FT)
FOR NORMAL ASSEMBLY APPLICATIONS

METRIC HARDWARE AND LOCKNUTS

NOMINAL SIZE	CLASS 5.8		CLASS 8.8		CLASS 10.9		LOCKNUT CL.8 W/CL8.8 BOLT
	UNPLATED	PLATED W/ZnCr	UNPLATED	PLATED W/ZnCr	UNPLATED	PLATED W/ZnCr	
M4	1.7 (15*)	2.2 (19*)	2.6 (23*)	3.4 (30*)	3.7 (33*)	4.8 (42*)	1.8 (16*)
M6	5.8 (51*)	7.6 (67*)	8.9 (79*)	12 (102*)	13 (115*)	17 (150*)	6.3 (56*)
M8	14 (124*)	18 (159*)	22 (195*)	28 (248*)	31 (274*)	40 (354*)	15 (133*)
M10	28 (21)	36 (27)	43 (32)	56 (41)	61 (45)	79 (58)	30 (22)
M12	49 (36)	63 (46)	75 (55)	97 (72)	107 (79)	138 (102)	53 (39)
M16	121 (89)	158 (117)	186 (137)	240 (177)	266 (196)	344 (254)	131 (97)
M20	237 (175)	307 (226)	375 (277)	485 (358)	519 (383)	671 (495)	265 (195)
M24	411 (303)	531 (392)	648 (478)	839 (619)	897 (662)	1160 (855)	458 (338)

NOTE: Torque values shown with * are inch pounds.

IDENTIFICATION HEX CAP SCREW AND CARRIAGE BOLTS CLASSES 5.6 AND UP

MANUFACTURER'S IDENTIFICATION

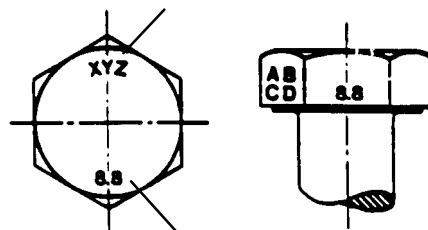

PROPERTY CLASS

HEX NUTS AND LOCKNUTS CLASSES 05 AND UP

MANUFACTURER'S IDENTIFICATION

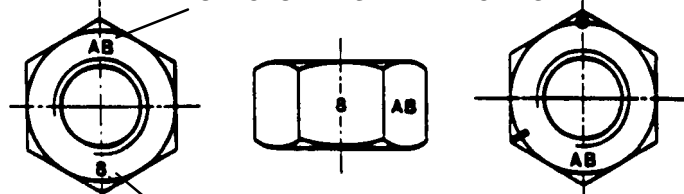

PROPERTY CLASS

CLOCK MARKING

**IN NEWTON-METRES - Nm (FOOT POUNDS - LBF. FT)
FOR NORMAL ASSEMBLY APPLICATIONS**

INCH HARDWARE AND LOCKNUTS

NOMINAL SIZE	SAE GRADE 2		SAE GRADE 5		SAE GRADE 8		LOCKNUTS		NOMINAL SIZE
	UNPLATED or PLATED SILVER	PLATED W/ZnCr GOLD	UNPLATED or PLATED SILVER	PLATED W/ZnCr GOLD	UNPLATED or PLATED SILVER	PLATED W/ZnCr GOLD	GR.B w/GR5 BOLT	GR.C w/GR8 BOLT	
1/4	6.2 (55*)	8.1 (72*)	9.7 (86*)	13 (112*)	14 (121*)	18 (157*)	6.9 (61*)	9.8 (86*)	1/4
5/16	13 (115*)	17 (149*)	20 (178*)	26 (229*)	28 (250*)	37 (324*)	14 (125*)	20 (176*)	5/16
3/8	23 (17)	30 (22)	35 (26)	46 (34)	50 (37)	65 (48)	26 (19)	35 (26)	3/8
7/16	37 (27)	47 (35)	57 (42)	73 (54)	80 (59)	104 (77)	41 (30)	57 (42)	7/16
1/2	57 (42)	73 (54)	87 (64)	113 (83)	123 (91)	159 (117)	61 (45)	88 (64)	1/2
9/16	81 (60)	104 (77)	125 (92)	163 (120)	176 (130)	229 (169)	88 (65)	125 (92)	9/16
5/8	112 (83)	145 (107)	174 (128)	224 (165)	244 (180)	316 (233)	122 (90)	172 (127)	5/8
3/4	198 (146)	256 (189)	306 (226)	397 (293)	432 (319)	560 (413)	217 (160)	306 (226)	3/4
7/8	193 (142)	248 (183)	495 (365)	641 (473)	698 (515)	904 (667)	350 (258)	494 (364)	7/8
1	289 (213)	373 (275)	742 (547)	960 (708)	1048 (773)	1356 (1000)	523 (386)	739 (545)	1

NOTE: Torque values shown with * are inch pounds.

**IDENTIFICATION
CAP SCREWS AND CARRIAGE BOLTS**



LOCKNUTS

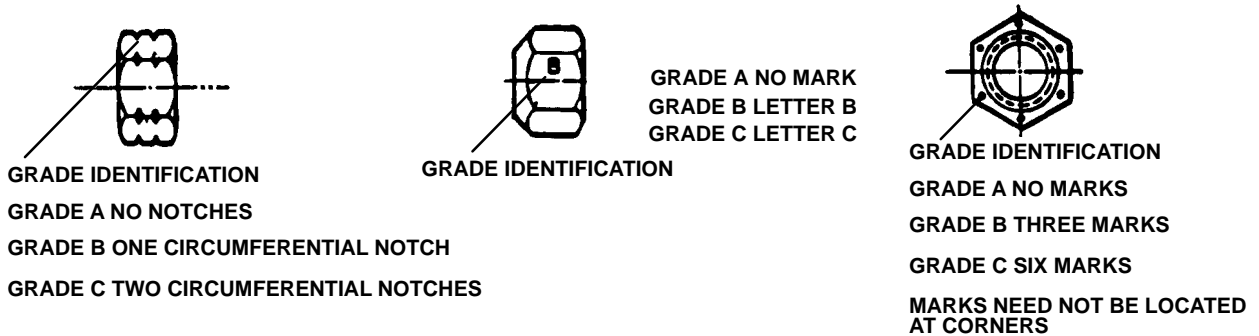

GENERAL INFORMATION

This Repair Manual provides the technical information needed to properly service the Wrapper.

Use this manual in conjunction with the Balers Repair Manual for complete operation, adjustment and maintenance information.

COMPONENTS OF THE BALER WRAPPER:

1. Performance monitor Control Panel
2. Balers Bale Chamber
3. Tailgate
4. Fork
5. Bale wrapping area
6. Satellite with Film dispenser's
7. Wrapping table

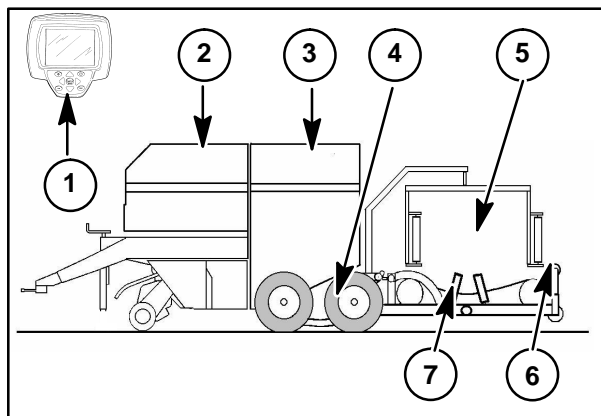

1

PERFORMANCE MONITOR

The monitor is used to view (1) and control (2) the different wrapper functions.

The monitor will also inform the operator continuously about the wrapping process with possible warnings or alarms.

IMPORTANT: Refer to the Baler Wrapper Operator Manual before attempting to operate the baler wrapper

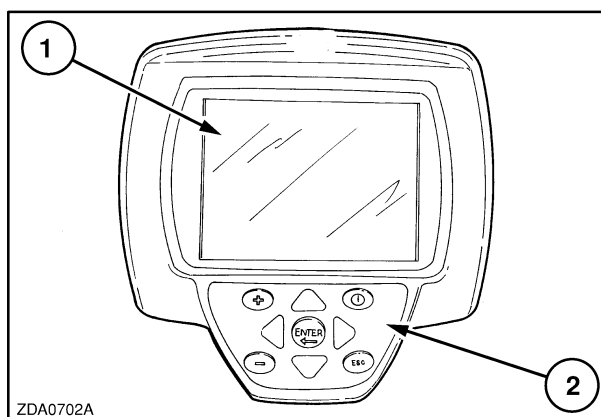

ZDA0702A

2

Section 4001.1

4001

ELECTRICAL SYSTEM RBX341 Round Baler Wrapper

4001.1-1 ELECTRICAL SYSTEM

BALER WRAPPER

CONTENT

Section	Description	Page
4001.1	Specifications	1
	Tooling	2
	Wrapper Control Module and sensors	5
	Description and Operation	9
	Schematics	15
	Fault Finding and Error Codes	53
	Connector Repair	207

SPECIFICATIONS

Baler monitor/controller	
Name	Baler performance monitor
	Automatic tailgate opening/closing choice through baler wrapper Performance monitor monitor
Electrical system	
Wrapper control module (WCM) – Installation	12 volts
Performance monitor	Connector 1 pin
Work lights (ON when Performance monitor ON - OFF when Performance monitor OFF)	Connector 7 pin
Beacon Light (ON with Performance monitor Off - OFF with Performance monitor ON)	Connector 1 pin
Accessory socket	12 volts
Fuse & Relay Board	Mounted above WCM
Relays	Work light and beacon operation
Fuse (Beacon light)	10 ampere
Fuse (Wrapper Control module)	15 ampere
Fuse (Work light)	15 ampere
Fuse (Wrapper circuit)	30 ampere
Fuse (In main line to tractor)	80 ampere
Alarms	Satellite out of position
	Bale stuck
	Emergency stop
	Tailgate open
	Film end/Film broken

Sensors	
B1 & B2	2x Film dispenser empty (no movement)
B3	3X Tailgate (open)
B4	3X Tailgate (closed)
B5	3X Tailgate (locked)
B6	1x Satellite home position (& wrap counting)
Sensors	
B7	1x Satellite speed (& relative position)
B8	1x Bale on transfer fork
B9	1x Transfer fork down
B10 & B11	2x Satellite emergency stop
B5, B7, B10, B11	Sensor type - M12 Flush (max distance 2mm)
B1, B2,	Sensor type - M12 Non flush (max distance 5mm)
B3, B4, B6, B8, B9	Sensor type - M18 Non flush (max distance 10mm)
Diagnoses. Error & value information	Sensors.
	Electro magnetic valves.
Rear auxiliary operation	Possibility with monitor and without (direct hydraulic valve operation)
Audible warning with manual operation	Buzzer mounted behind fuse relay board

TOOLING

A standard multi meter is sufficient for all general electrics testing.

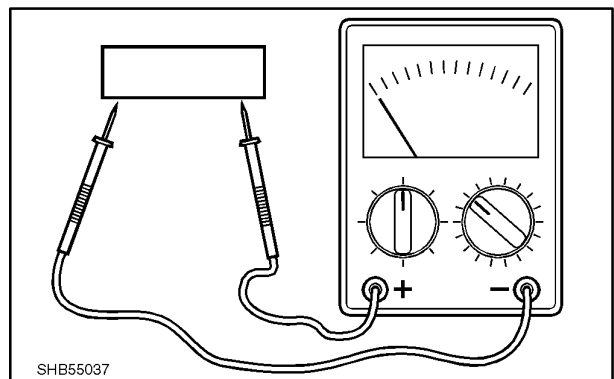



Suggest:

For more complete manuals. Please go to the home page.

<https://www.ebooklibonline.com>

If the above button click is invalid. Please download this document first, and then click the above link to download the complete manual.

Thank you so much for reading

GENERAL INFORMATION

Through the following pages are brief outlines of the wrapper electrics, for example:

PERFORMANCE MONITOR TO WCM

As shown through the connector X201 to the monitor the following connections are made:

CAN High CAN Low, ground, WCM, Battery, and 12volt Key Start, all of which are protected by individual fuses and overall are protected by the main 80 ampere fusible link in the tractor to baler harness.

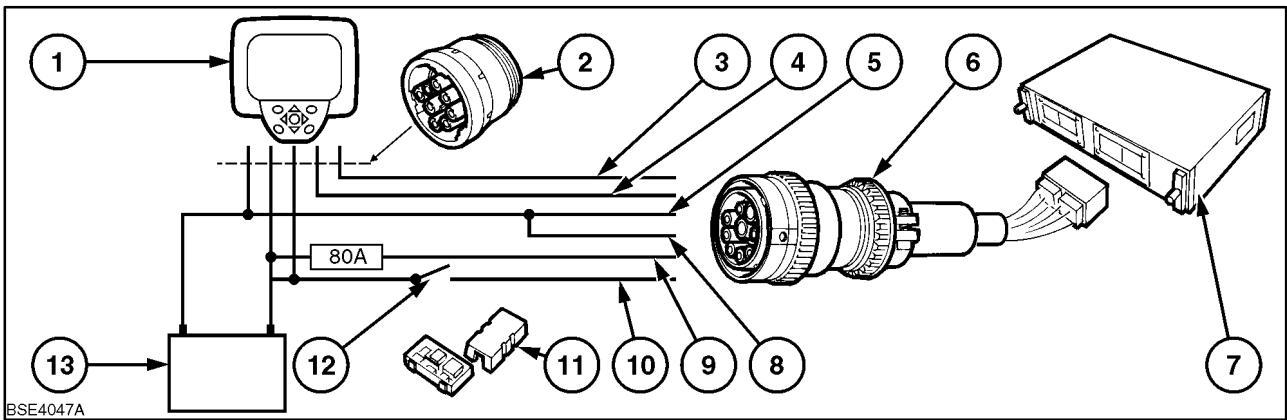

- | | |
|---------------------------------|---------------------------------|
| 1. Monitor | 8. WCM Ground |
| 2. Connector X201 | 9. Power |
| 3. CAN High | 10. 12 volts |
| 4. CAN Low | 11. 80 ampere main fusible link |
| 5. Ground | 12. Key start |
| 6. Connector X201 | 13. Battery |
| 7. Wrapper Control Module (WCM) | |

WRAPPER CIRCUIT

Shown below is the circuit of the baler wrapper electrics from the WCM and its control of the lights (when fitted).

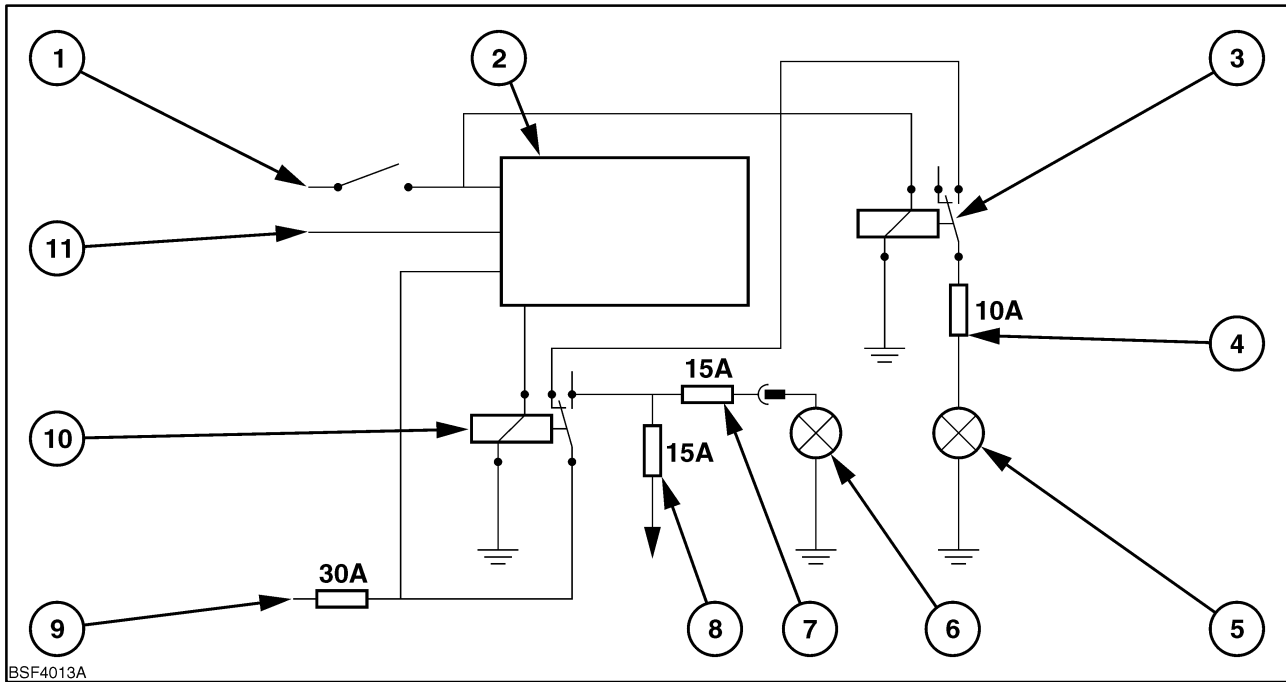

BSF4013A

- | | |
|-----------------------------------|---|
| 1. WCM Power IN | 7. 15 ampere fuse to work light |
| 2. WCM | 8. 15 ampere fuse to WCM |
| 3. Beacon relay | 9. 30 ampere fuse for wrapper circuit |
| 4. 10 ampere fuse to beacon light | 10. Relay operated from display ON signal |
| 5. Beacon light | 11. Monitor Display |
| 6. Worklight | |

Lighting

The work lights and beacon light work in conjunction with the WCM (work mode, or road mode) as described below.

	Flashing Beacon (Road mode)	Worklight (Work mode)	Wrapper operational (Work mode)
Power (connected)	OFF	OFF	OFF
Switch ON (WCM pwr)	ON	OFF	OFF
Display ON	OFF	ON	ON

<https://www.ebooklibonline.com>

Hello dear friend!

Thank you very much for reading.

Enter the link into your browser.

The full manual is available for immediate download.

<https://www.ebooklibonline.com>