

RBX341

Repair Manual

CE

6-71140EN

CASE III[®]



REPAIR MANUAL

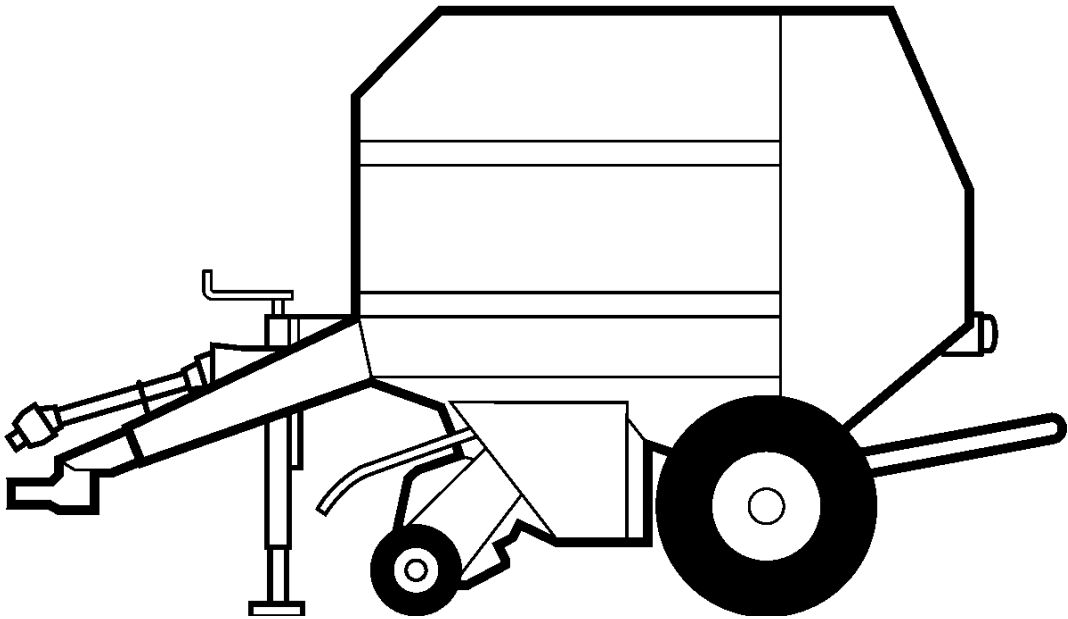

RBX341

Contents

INTRODUCTION	
DISTRIBUTION SYSTEMS	A
POWER PRODUCTION	B
POWER TRAIN	C
TRAVELLING	D
CROP PROCESSING	K

<https://www.ebooklibonline.com>

Hello dear friend!

Thank you very much for reading.

Enter the link into your browser.

The full manual is available for immediate download.

<https://www.ebooklibonline.com>



INTRODUCTION

Safety rules (- A.50.A.10)

RBX341

IMPORTANT INFORMATION

- All repair and maintenance works listed in this manual must be carried out only by staff belonging to the Manufacturers Service network, strictly complying with the instructions given and using, whenever required, the special tools.
Anyone who carries out the above operations without complying with the prescriptions shall be responsible for the subsequent damages.
- The manufacturer and all the organizations of its distribution chain, including - without limitation - national, regional or local dealers, reject any responsibility for damages due to the anomalous behaviour of parts and/or components not approved by the manufacturer himself, including those used for the servicing or repair of the product manufactures or marketed by the Manufacturer.
- In any case, no warranty is given or attributed on the product manufactures of marketed by the Manufacturer in case of damages due to an anomalous behaviour of parts and/or components not approved by the Manufacturer. No reproduction, though partial of text and illustrations allowed

SAFETY INFORMATION

WARNING AND DANGER SYMBOLS

- Warning symbols point out important personal safety messages. Carefully read the following safety regulations and observe advised precautions in order to avoid potential hazards and safeguard your health and safety. In this manual the symbol is accompanied by the following key words:
- "DANGER", "CAUTION", "WARNING". Warnings concerning unsuitable repair operations that may jeopardize the safety of Repair personnel.
DANGER - Specific warnings concerning potential hazards for operator safety or for other persons directly or indirectly involved.

ACCIDENT PREVENTION

- Most accidents or injuries that occur in workshops are the result of non observance of simple and fundamental safety regulations.
For this reason, IN MOST CASES THESE ACCIDENTS CAN BE AVOIDED by foreseeing possible causes and consequently acting with the necessary caution and care. Accidents may occur with all types of machine, regardless of how well the machine in question was designed and built. A careful and judicious service technician is the best guarantee against accidents. Precise observance of the most basic safety rule is normally sufficient to avoid many serious accident

DANGER

- Never carry out any cleaning, lubrication or maintenance operations when the tractor engine is running.

SAFETY RULES AND REGULATIONS

- Carefully follow specified repair and maintenance procedures.
- Do not wear rings, wrist watches, jewelry, unbuttoned or loose articles of clothing such as: ties, torn clothing, scarves, open jackets or shirts with open zips that may remain entangled in moving parts. It is advised to wear approved safety clothing, e.g.: non slip footwear, gloves, safety goggles, helmets, etc.
- Do not carry out repair operations with someone sitting in the driver's seat, unless the person is a trained technician who is assisting with the operation in question.
- Do not operate the machine or use any of the implements from different positions, other than the driver's seat.
- Do not carry out operations on the machine with the tractor engine running, unless specifically indicated.
- Stop the tractor engine and check that the hydraulic circuits are pressure-free before removing caps, covers, valves, etc.
- All repair and maintenance operations must be carried out using extreme care and attention.
- Service steps and platforms used in the workshop or elsewhere should be built according to standard accident prevention regulations.
- Disconnect the p.t.o. from the tractor and label all controls to indicate that the machine is being serviced. Any parts that are to be raised must be locked in position.

INTRODUCTION

- Brakes are inoperative when manually released for repair or maintenance purposes. Use blocks or similar devices to control the machine in these conditions.
- Only use specified towing points for towing the machine. Connect parts carefully. Make sure that all pins and/or locks are secured in position before applying traction. Never remain near the towing bars, cables or chains that are operating under load.
- When loading or unloading the machine from the trailer (or other means of transport), select a flat area capable of sustaining the trailer or truck wheels. Firmly secure the machine to the truck or trailer and lock the wheels in the position used by the carrier.
- Electric heaters, battery-chargers and similar equipment must only be powered by auxiliary power supplies with efficient ground insulation to avoid electrical shock hazards.
- Always use suitable hoisting or lifting devices when raising or moving heavy parts. Take extra care if bystanders are present.
- Never use petrol, diesel oil or other inflammable liquids as cleaning agents. Use non inflammable, non toxic commercially available solvents.
- Wear safety goggles with side guards when cleaning parts with compressed air. Reduce the air pressure according to the local regulations in force.
- Do not run the tractor engine in confined spaces without suitable ventilation.
- Never use naked flames for lighting when working on the machine or checking for leaks.
- All movements must be carried out carefully when working under, on or near the machine. Wear protective equipment: helmets, goggles and special footwear.
- When carrying out checks with the tractor engine running, request the assistance of an operator in the driver's seat. The operator must maintain visual contact with the service technician at all times.
- If operating outside the workshop, position the machine on a flat surface and lock in position. If working on a slope, lock the machine in position. Move to a flat area as soon as is safely possible.
- Damaged or bent chains or cables are unreliable. Do not use them for lifting or towing. Always use suitable protective gloves when handling chains or cables.
- Chains should always be safely secured. Make sure that the hitch-up point is capable of sustaining the load in question. Keep the area near the hitch-up point, chains or cables free of all bystanders.
- Maintenance and repair operations must be carried out in a CLEAN and DRY area. Eliminate any water or oil spillage immediately.
- Do not create piles of oil or grease-soaked rags as they represent a serious fire hazard. Always store rags in a closed metal container. Before engaging the machine, make sure that there are no persons within the machine or implement range of action.
- Empty your pockets of all objects that may fall accidentally unobserved into the machine inner compartments.
- In the presence of protruding metal parts, use protective goggles or goggles with side guards, helmets, special footwear and gloves.
- When welding, use protective safety devices: tinted safety goggles, helmets, special overalls, gloves and footwear. All persons present in the area where welding is taking place must wear tinted goggles. **NEVER LOOK DIRECTLY AT THE WELDING ARC WITHOUT SUITABLE EYE PROTECTION.**
- Metal cables tend to fray with repeated use. Always use suitable protective devices (gloves, goggles, etc.) when handling cables.
- Handle all parts carefully. Do not put your hands or fingers between moving parts. Wear suitable safety clothing - safety goggles, gloves and shoes.

START UP

- Never run the tractor engine in confined spaces that are not equipped with adequate ventilation for exhaust gas extraction.
Never place the head, body, limbs, feet, hands or fingers near rotating and moving parts.

HYDRAULIC SYSTEMS

- A liquid leaking from a tiny hole may be almost invisible but, at the same time, be powerful enough to penetrate the skin.

INTRODUCTION

Therefore, NEVER USE HANDS TO CHECK FOR LEAKS but use a piece of cardboard or wood for this purpose.

If any liquid penetrates skin tissue, call for medical aid immediately. Failure to treat this condition with correct medical procedure may result in serious infection or dermatosis.

In order to check the pressure in the system use suitable instruments.

WHEELS AND TYRES

- Make sure that the tyres are correctly inflated at the pressure specified by the manufacturer.
Periodically check the rims and tyres for damage.
Stand away from (at the side of) the tyre when checking inflation pressure.
Do not use parts of recovered wheels as incorrect welding brazing or heating may weaken and eventually cause damage to the wheel.
Never cut or weld a rim mounted with an inflated tyre.
To remove the wheels, lock all wheels. After having raised the machine, position supports underneath, according to regulations in force.
Deflate the tyre before removing any objects that may be jammed in the tyre tread.
Never inflate tyres using inflammable gases, as this may result in explosions and injury to bystanders.

REMOVAL AND REFITTING

- Lift and handle all heavy parts using suitable hoisting equipment. Make sure that parts are sustained by appropriate hooks and slings. Use the hoisting eyebolts for lifting operations. Extra care should be taken if persons are present near the load to be lifted.
Handle all parts carefully. Do not put your hands or fingers between parts. Wear suitable safety clothing - safety goggles, gloves and shoes.
Avoid twisting chains or metal cables. Always wear safety gloves when handling cables or chains.

HAULING THE BALER

- When hauling the baler, always make sure that all loose components are securely fastened to the machine:
P.t.o. front half
Spare net roll basket
Hydraulic hoses
Bale command monitor and road light wire harnesses
Twine balls
Net rolls
Pick-up wheels
Bale command operator panel, tractor wire harness and battery cable
Operator's manual
Close all guards and lock the pick-up in the transport position. When the baler has to be lifted for transport, special attention must be paid to the attachment of the sling hooks. The baler is equipped with two lifting eyes in the tailgate hinge area. A third sling hook must be attached to the hitch eye. Adapt the length of the lifting chains so that they join each other over the baler's center of gravity as shown in Figure 6 (for low hitch) and Figure 7 (for high hitch). Join the chains high enough above the baler to avoid lifting chain interference with the front access door or the conveyor chain idler rollers.

IMPORTANT: Use chains of adapted strength regarding the baler weight of **2600-2700 kg 5732-5952 lb(empty)**.

Lifting Chains

INTRODUCTION

1.

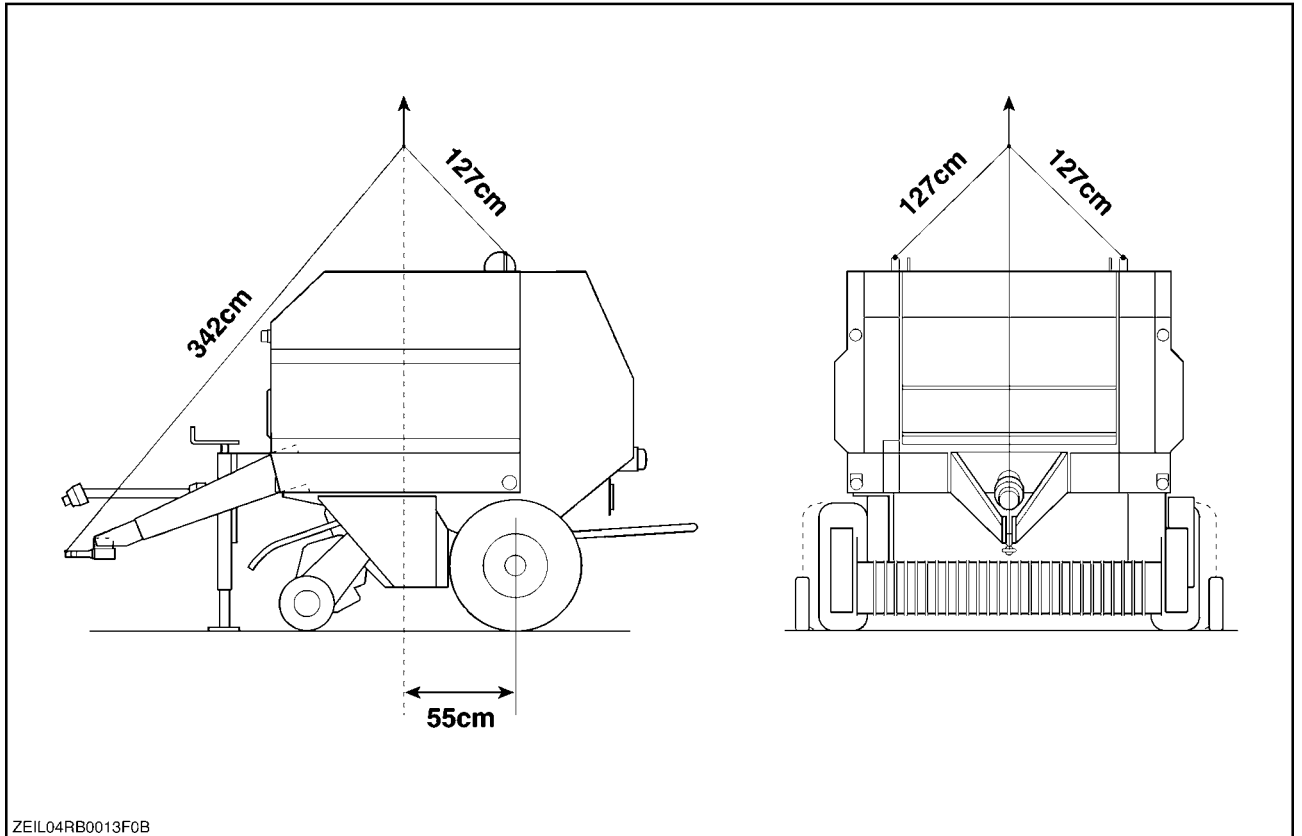

ZEIL04RB0013F0B 1

2.

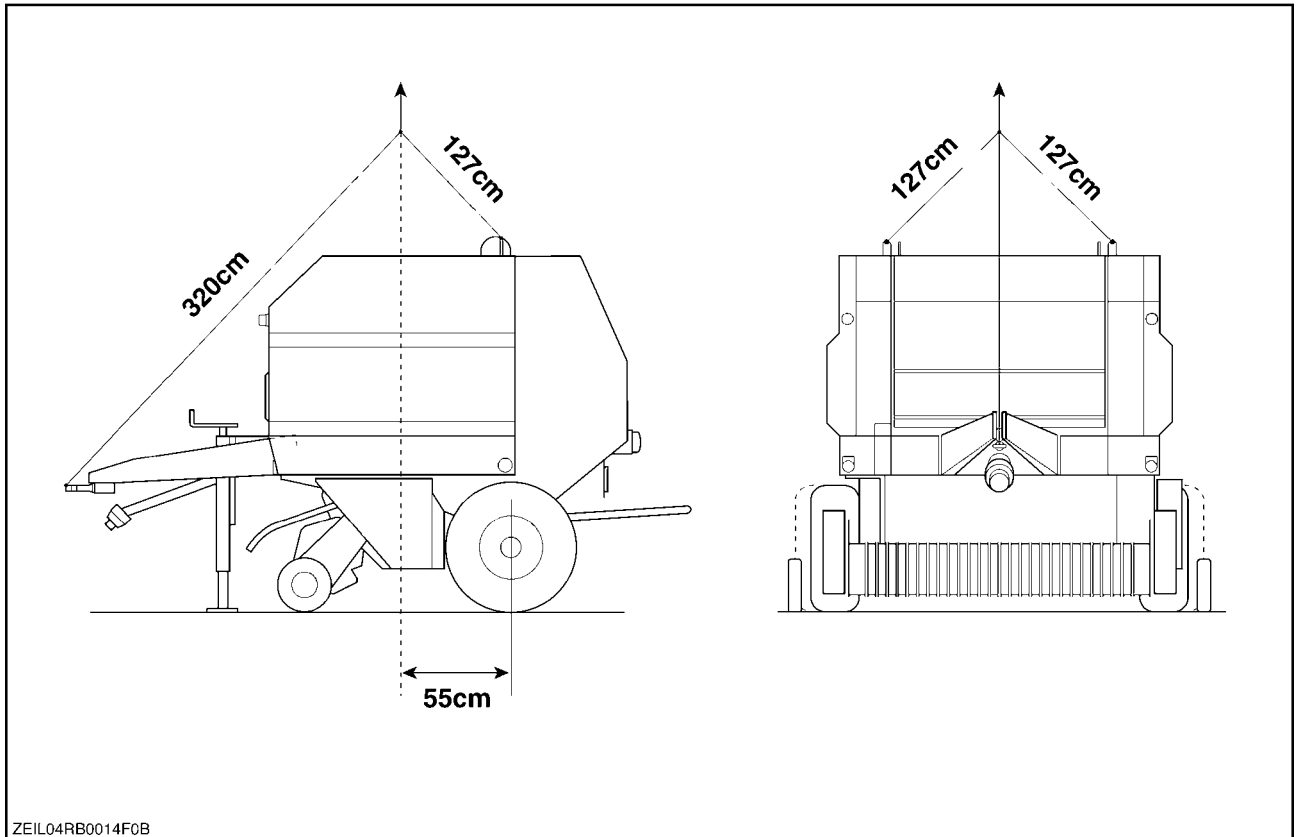

ZEIL04RB0014F0B 2

Torque (- A.90.A.10)

RBX341

Minimum hardware tightening torques Nm lb ft lb in for normal assembly applications unless otherwise stated

IMPORTANT: Shown below is the suggested initial torque tightening sequences for general applications, tighten in sequence from item 1 through to the last item of the hardware.

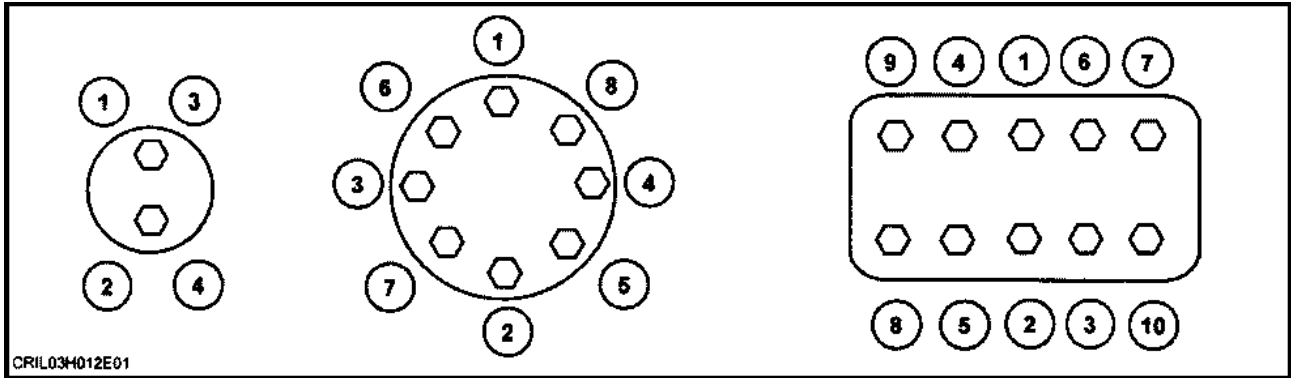

CRIL03M012E01

df5019-1 1

Imperial hardware

Nominal Size	SAE GRADE 2 Unplated or Silver plated	SAE GRADE 2 plated w/ZnCr GOLD	SAE GRADE 5 Unplated or Silver plated	SAE GRADE 5 plated w/ZnCr GOLD	SAE GRADE 8 Unplated or Silver plated	SAE GRADE 8 plated w/ZnCr GOLD	LOCK-NUTS GR.B w/GR5 BOLT	LOCK-NUTS GR.B w/GR8 BOLT
1/4	6.2 Nm 55 lb in	8.1 Nm 72 lb in	9.7 Nm 86 lb in	13 Nm 112 lb in	14 Nm 121 lb in	18 Nm 157 lb in	6.9 Nm 61 lb in	9.8 Nm 86 lb in
5/16	13 Nm 115 lb in	17 Nm 149 lb in	20 Nm 178 lb in	26 Nm 229 lb in	28 Nm 250 lb in	37 Nm 324 lb in	14 Nm 125 lb in	20 Nm 176 lb in
3/8	23 Nm 17 lb ft	30 Nm 22 lb ft	35 Nm 26 lb ft	46 Nm 34 lb ft	50 Nm 37 lb ft	65 Nm 48 lb ft	26 Nm 19 lb ft	35 Nm 26 lb ft
7/16	37 Nm 27 lb ft	47 Nm 35 lb ft	57 Nm 42 lb ft	73 Nm 54 lb ft	80 Nm 59 lb ft	104 Nm 77 lb ft	41 Nm 30 lb ft	57 Nm 42 lb ft
1/2	27 Nm 42 lb ft	73 Nm 54 lb ft	87 Nm 64 lb ft	113 Nm 83 lb ft	123 Nm 91 lb ft	159 Nm 117 lb ft	61 Nm 45 lb ft	88 Nm 64 lb ft
9/16	81 Nm 60 lb ft	104 Nm 77 lb ft	125 Nm 92 lb ft	163 Nm 120 lb ft	176 Nm 130 lb ft	229 Nm 169 lb ft	88 Nm 65 lb ft	125 Nm 92 lb ft
5/8	112 Nm 83 lb ft	145 Nm 107 lb ft	174 Nm 128 lb ft	224 Nm 165 lb ft	244 Nm 180 lb ft	316 Nm 233 lb ft	122 Nm 90 lb ft	172 Nm 127 lb ft
3/4	198 Nm 146 lb ft	256 Nm 189 lb ft	306 Nm 226 lb ft	397 Nm 293 lb ft	432 Nm 319 lb ft	560 Nm 413 lb ft	217 Nm 160 lb ft	305 Nm 226 lb ft
7/8	193 Nm 142 lb ft	248 Nm 183 lb ft	495 Nm 365 lb ft	641 Nm 473 lb ft	698 Nm 515 lb ft	904 Nm 667 lb ft	350 Nm 258 lb ft	494 Nm 364 lb ft
1.0	289 Nm 213 lb ft	373 Nm 275 lb ft	742 Nm 547 lb ft	960 Nm 708 lb ft	1048 Nm 773 lb ft	1356 Nm 1000 lb ft	523 Nm 386 lb ft	739 Nm 545 lb ft

INTRODUCTION

Metric hardware

Nominal Size	CLASS 5.8 UNPLATED	CLASS 5.8 UNPLATED	CLASS 8.8 UNPLATED	CLASS 8.8 UNPLATED	CLASS 10.9 UNPLATED	CLASS 10.9 UNPLATED	LOCKNUT CL.8 w/CL8.8 BOLT
M4	1.7 Nm 15 lb in	2.2 Nm 19 lb in	2.6 Nm 23 lb in	3.4 Nm 30 lb in	3.7 Nm 33 lb in	4.8 Nm 42 lb in	1.8 Nm 16 lb in
M6	5.8 Nm 51 lb in	7.6 Nm 67 lb in	8.9 Nm 79 lb in	12 Nm 102 lb in	13 Nm 115 lb in	17 Nm 150 lb in	6.3 Nm 56 lb in
M8	14 Nm 124 lb in	18 Nm 159 lb in	22 Nm 195 lb in	28 Nm 248 lb in	31 Nm 274 lb in	40 Nm 354 lb in	15 Nm 133 lb in
M10	28 Nm 21 lb ft	36 Nm 27 lb ft	43 Nm 32 lb ft	56 Nm 41 lb ft	61 Nm 45 lb ft	79 Nm 58 lb ft	30 Nm 22 lb ft
M12	49 Nm 36 lb ft	63 Nm 46 lb ft	75 Nm 55 lb ft	97 Nm 72 lb ft	107 Nm 79 lb ft	138 Nm 102 lb ft	53 Nm 39 lb ft
M16	121 Nm 89 lb ft	158 Nm 117 lb ft	186 Nm 137 lb ft	240 Nm 177 lb ft	266 Nm 196 lb ft	344 Nm 254 lb ft	131 Nm 97 lb ft
M20	237 Nm 175 lb ft	307 Nm 107 lb ft	375 Nm 277 lb ft	485 Nm 358 lb ft	519 Nm 383 lb ft	671 Nm 495 lb ft	265 Nm 195 lb ft
M24	411 Nm 303 lb ft	531 Nm 392 lb ft	648 Nm 478 lb ft	839 Nm 619 lb ft	897 Nm 662 lb ft	1160 Nm 855 lb ft	458 Nm 338 lb ft

**IDENTIFICATION
CAP SCREWS AND CARRIAGE BOLTS**



SAE
GRADE 2



SAE
GRADE 5



SAE
GRADE 8



REGULAR
NUTS



SAE
GRADE 5
HEX NUTS



SAE
GRADE 8
NUTS

LOCKNUTS

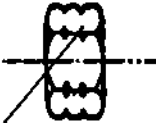

GRADE IDENTIFICATION
GRADE A NO NOTCHES
GRADE B ONE CIRCUMFRETIAL NOTCH
GRADE C TWO CIRCUMFRETIAL NOTCHES



GRADE IDENTIFICATION
GRADE A NO MARK
GRADE B LETTER B
GRADE C LETTER C



GRADE IDENTIFICATION
GRADE A NO MARKS
GRADE B THREE MARKS
GRADE C SIX MARKS

MARKS NEED NOT BE
LOCATED
AT CORNERS

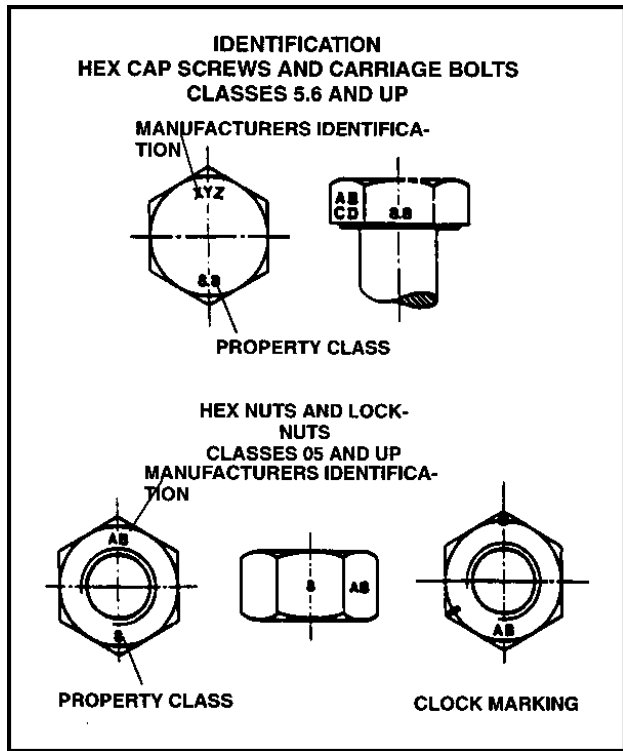

dave5019 3

General specification (- A.92.A.10)

RBX341

GENERAL INFORMATION

- This Repair Manual provides the technical information needed to properly service the round balers. Use this manual in conjunction with the Operator's Manual for complete operation, adjustment and maintenance information. On this equipment, left and right are determined by standing behind the unit, looking in the direction of travel.
- The descriptions and specifications contained in this manual were in effect at the time the manual was released for printing. The company reserves the right to discontinue models at any time, or to change specifications and design without notice and without incurring obligation.
- NOTE: Some illustrations in this manual were made of prototype or previous production models. Current production models may vary in some detail.

SHIMMING

- For each adjustment operation, select adjusting shims and measure individually using a micrometer, then add up the recorder values. Do not rely on measuring the entire shimming set, which may be incorrect, or the rated value indicated for each on shim.

ROTATING SHAFT SEALS

- For correct rotating shaft seal installation, proceed as follows:
- before assembly, allow the seal to soak in the oil it will be sealing for at least thirty minutes
- thoroughly clean the shaft and check that the working surface on the shaft is not damaged
- position the sealing lip facing the fluid; with hydrodynamic lips, take into consideration the shaft rotation direction and position the grooves so that they will deviate the fluid towards the inner side of the seal
- coat the sealing lip with a thin layer of lubricant (use oil rather than grease) and fill the gap between the sealing lip and the dust lip on double lip seals with grease
- insert the seal in its seat and press down using a flat punch, do not tap the seal with a hammer or mallet
- whilst inserting the seal, check that the it is perpendicular to the seat; once settled, make sure that it makes contact with the thrust element, if required
- to prevent damaging the seal lip on the shaft, position a protective guard during installation operations

O-RING SEALS

- Lubricate the O-RING seals before inserting them in the seats, this will prevent them from overturning and twisting, which would jeopardise sealing efficiency.

SEALING COMPOUNDS

- Apply one of the following sealing compounds on the mating surfaces marked with an X: RTV SILMATE, RHODORSIL CAF 1 or LOCTITE PLASTIC GASKET.
Before applying the sealing compound, prepare the surfaces as follows:
remove any incrustations using a metal brush;
thoroughly de-grease the surfaces using one of the following cleaning agents: trichlorethylene, petrol or a water and soda solution.

COTTER PINS

- When fitting split cotter pins, ensure that the pin notch is positioned in the direction of the force required to stress the pin. Spiral cotter pins do not require special positioning.

SPARE PARTS

- Only use original spare parts bearing the COMPANY logo.
Only genuine spare parts guarantee the same quality, duration and safety as original parts, as they are the same parts that are assembled during standard production. Only genuine spare parts can offer this guarantee. When ordering spare parts, always provide the following information:
Machine model (commercial name) and serial number
Part number of the ordered part, which can be found in the Spare Parts Catalogue, used for order processing

INTRODUCTION

TOOLS

- The tools that manufacturer suggests and illustrates in this manual have been:
 - specifically researched and designed for use with these machines
 - essential for reliable repair operations
 - accurately built and rigorously tested so as to offer efficient and long-lasting operation.
 By using these tools, Repair Personnel will benefit from:
 - operating in optimal technical conditions
 - obtaining the best results - saving time and effort
 - working in safe conditions

NOTE: Wear limit values indicated for certain parts should be considered to be recommended, but not binding. The terms "front", "rear", "right-hand" and "left-hand" (when referred to different parts) are determined from the rear, facing in the direction of travel of the machine during operation.

TECHNICAL DATA

WEIGHT	
Twine only baler	2600 kg 6965 lb
Net/Twine baler	2685 kg 7193 lb
TRACTOR REQUIREMENTS	
PTO Input requirements without knives	
Minimum	37 kW 50 Hp
Recommended	52 kW 70 Hp
Crop cutter 7 knives engaged	
Minimum	57 kW 77 Hp
Reccomended	40 kW 55 Hp
Crop cutter 15 knives engaged	
Minimum	44 kW 60 Hp
Reccomended	62 kW 85 Hp
HYDRAULICS	
2 single-acting valves	Minimum 124 bar 1798 psi Maximum 210 bar 3045 psi
Output at RPM	Minimum 45 L/min11.88 US gal
PTO	
ELECTRICS	
Bale command plus system	13.5 volts +/- 0.5
Road light equipment	B7 DINN72577 - 7 PIN
HITCH HEIGHT	
Low hitch	450-550 mm 17.7-61.65 in
High hitch	750-1000 mm 29.5-39.37 in
BALE CHAMBER	
Width and Diameter	120 cm 47.2 in
BALE WEIGHT	
Range Minimum-Maximum	120-800 kg 321-2143 lb
Typical Straw	120-200 kg 321-535 lb
Hay	180-300 kg 482-803 lb
Silage	350-800 kg 937-2143 lb



Suggest:

For more complete manuals. Please go to the home page.

<https://www.ebooklibonline.com>

If the above button click is invalid. Please download this document first, and then click the above link to download the complete manual.

Thank you so much for reading

Consumables (- A.92.A.55)

RBX341

Description	Service Interval	Capacity	Brand	International Specification
Multipurpose Grease	10hr - Daily 50hr - Weekly 400hr - Annually		CASE AKCELA 251H EP MULTI-PURPOSE GREASE	NLG1 - Class 2
Gearbox oil	400hr - Annually	1 L 0.26 US gal	CASE AKCELA 135H EP GEAR LUBE SAE 80W-90	API GL5, MIL-L-2105 D SAE 80W-90
Chain Oil	50hr - Weekly		CASE AKCELA HYDRAULIC EXCAVATORS FLUID BIO	DIN 51524 part 2 HV 46 ISO VG 46 API CE-MIL-L-2104E MV46
Automatic lubrication system	10hr - Daily	3 L 0.8 US gal	CASE AKCELA HYDRAULIC EXCAVATOR FLUIDCASE AKCELA HYDRAULIC EXCAVATORS FLUID BIO	DIN 51524 Part 2 HV 46 ISO VG 46 API CE-MIL-L-2104E
Linkages and rods	50hr - Weekly		CASE AKCELA HYDRAULIC EXCAVATORS FLUID BIO	DIN 51524 part 2 HV 46 ISO VG 46 API CE-MIL-L-2104E MV46 BIO

Dimension (- A.92.A.30)

RBX341

GENERAL DIMENSIONS

- The specification figures in this section are provided for your information and guidance. Company policy is one of continuous improvement and the right to change prices, specification or equipment at any time without notice is reserved. All data given in this manual is subject to production variation. Dimensions and weights are approximate only. The illustrations do not necessarily show balers in standard condition or imply that these features are available in all countries.

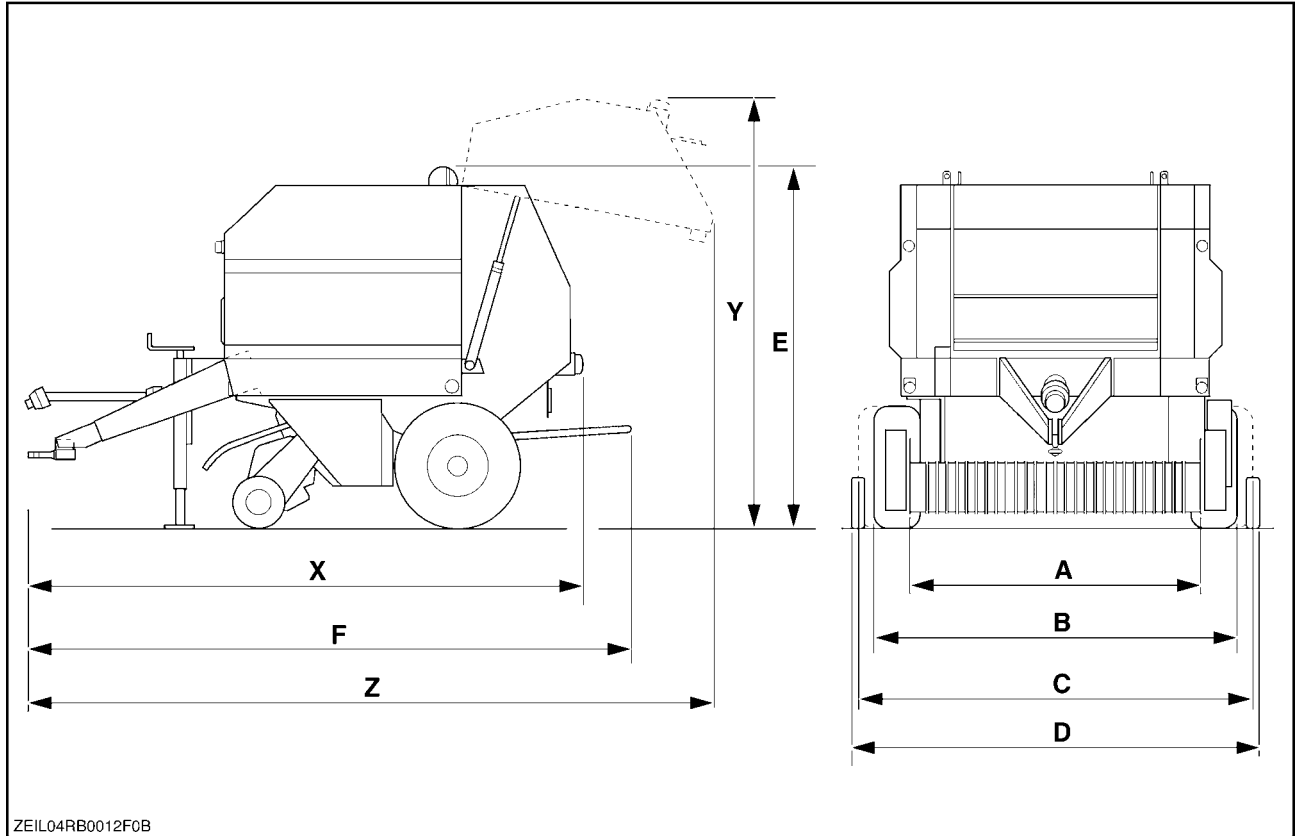

ZEIL04RB0012F0B 1

WIDTH

A	Pick up	2 m 6.56 ft
B	Ground wheels (standard machines)	2.4 m 7.87 ft
C	Ground wheels (crop cutting machines)	2.5 m 8.2 ft
D	Maximum (pick up wheels installed)	2.69 m 8.82 ft

LENGTH

X	Low hitch Bale ejector excluded	3.65 m 11.97 ft
F	Bale ejector included	3.95 m 12.95 ft
Z	Maximum (tailgate open) High hitch = low hitch + 0.15	4.5 m 14.76 ft

HEIGHT

E	Tailgate closed	2.35 m 7.7 ft
Y	Tailgate opened	2.7 m 8.858 ft

<https://www.ebooklibonline.com>

Hello dear friend!

Thank you very much for reading.

Enter the link into your browser.

The full manual is available for immediate download.

<https://www.ebooklibonline.com>