

MAXXFARM 35

Preliminary Service Manual

May 2009

47673549

NB: For Maxxfarm 35 refer to the i36 model listed in this manual



INDEX

Section	Content	No.
General information	Model identification and serial number location; component location; specifications	1
Overhaul instructions	Determining when to overhaul the engine; compression pressure measurement; troubleshooting; basic precautions for disassembly and assembly	2
Disassembly	Preparation for disassembly; electrical system; cooling system; fuel system; lubrication system; air inlet system and exhaust system; cylinder head and valve mechanism; timing gears and flywheel; cylinder block, crankshaft, pistons and oil pan	3
Inspection	Cylinder head and valve mechanism; timing gears and flywheel; cylinder block, crankshaft, pistons and oil pan	4
Assembly	Cylinder block, crankshaft, pistons and oil pan; timing gears and flywheel; cylinder head and valve mechanism; air inlet system and exhaust system; fuel system; lubrication system; cooling system; electrical system	5
Electrical system	General; starter; alternator; key shutoff system; automatic glow timer system	6
Cooling system	General; inspection (water pump; thermostat; thermoswitch; thermounit)	7
Lubrication system	General; inspection (oil pump; oil pressure switch; pressure relief valve)	8
Fuel system	General; fuel injection nozzle; fuel injection pump; governor; fuel pump; fuel filter	9
Air inlet system and exhaust system	General; Inspection	10
Maintenance	Lubrication and maintenance chart; engine oil and oil filter; valve clearance; fuel injection timing; fuel filter; fuel system priming; idle rpm setting; fuel injection nozzle; fan belt	11
Service data	Specifications; tightening torques; sealants; special tools	12

1

2

3

4

5

6

7

8

9

10

11

12

GENERAL INFORMATION

MODEL IDENTIFICATION AND SERIAL NUMBER LOCATION

1. Model identification location	2
2. Serial number location	2

1

COMPONENT LOCATION

S3L/S3L2	3
S4L/S4L	4

SPECIFICATIONS	5
----------------------	---

PERFORMANCE CURVES (ONE-HOUR RATING, WITH FAN)	6
--	---

PRIME POWER OUTPUT CHART	6
--------------------------------	---

<https://www.ebooklibonline.com>

Hello dear friend!

Thank you very much for reading.

Enter the link into your browser.

The full manual is available for immediate download.

<https://www.ebooklibonline.com>

GENERAL INFORMATION

MODEL IDENTIFICATION AND SERIAL NUMBER LOCATION

1. Model identification location

- (a) The model identification is embossed on the right side of the cylinder block, near the fuel injection pump mount.
- (b) The model identifications and displacements of the engines in current production are as listed below:

	Displacement
S3L	1.125 liters (68.7 cu in.)
S3L2	1.318 liters (80.4 cu in.)
S4L	1.500 liters (91.5 cu in.)
S4L2	1.758 liters (107.3 cu in.)

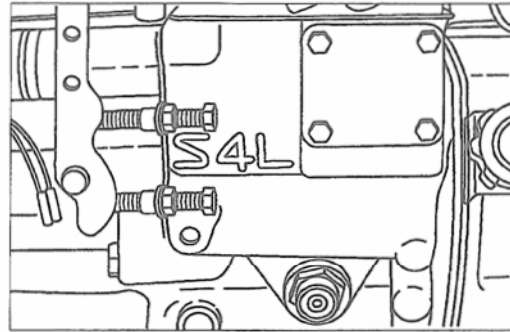

Model identification location

- (c) A scheme of coding used for identifying the engines in current production is as follows:

Example: Coded designation

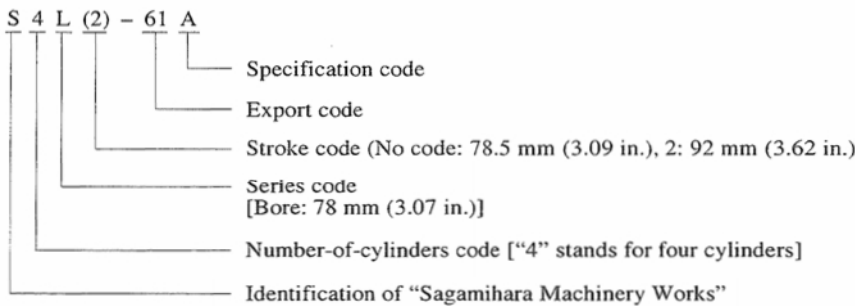

2. Serial Number Location

The serial number is punched on the cylinder block, near the fuel injection pump mount.

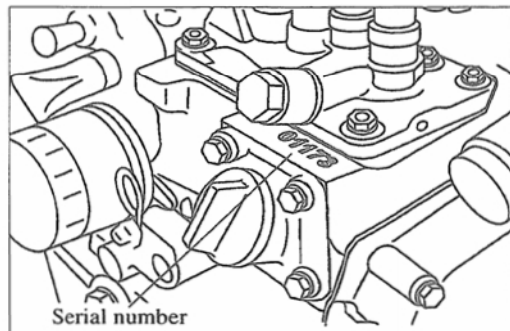

Serial number location

COMPONENT LOCATION

S3L/S3L2

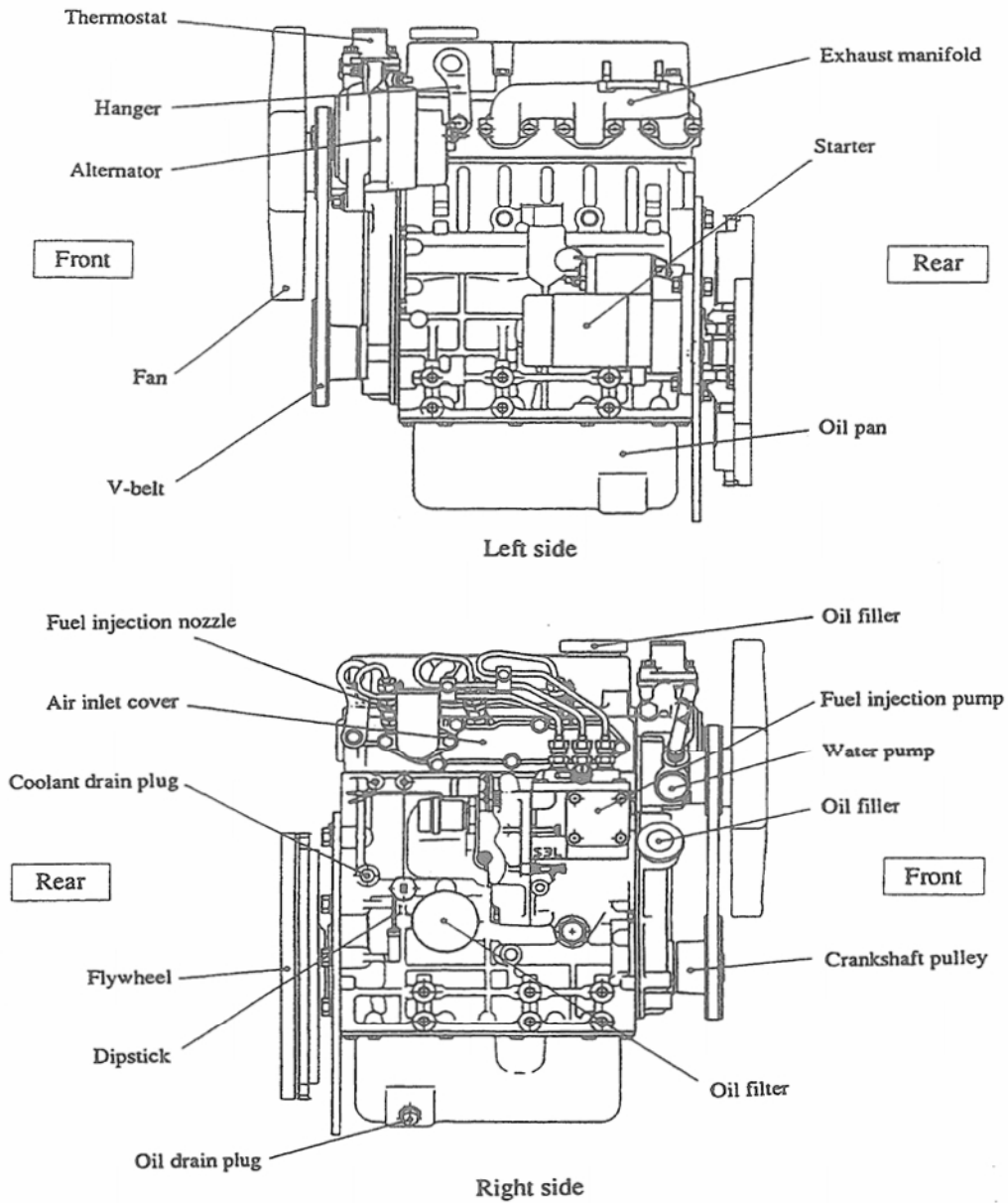

GENERAL INFORMATION

S4L/S4L2

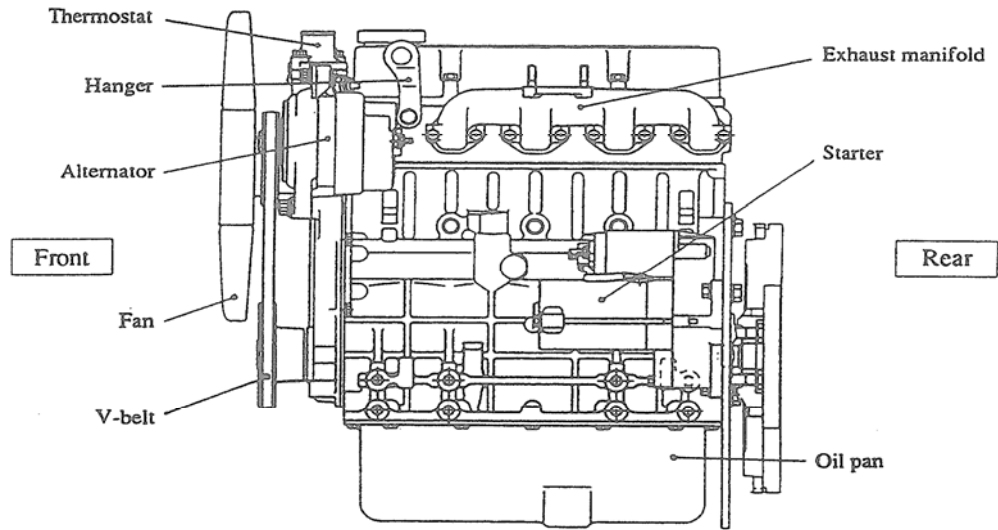

Left side

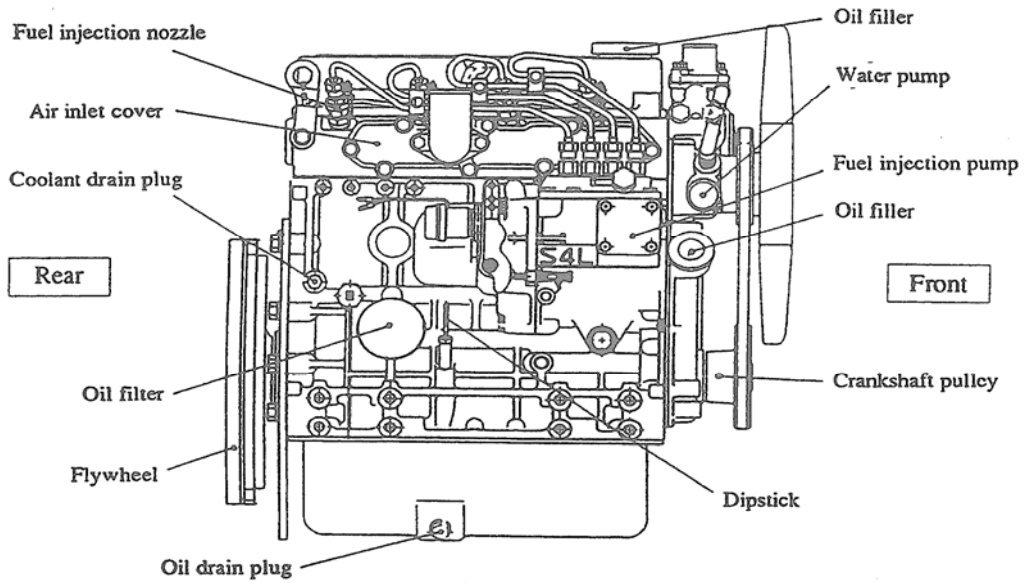

Right side

SPECIFICATIONS

Model		S3L	S3L2	S4L	S4L2
Type		Water-cooled, 4-stroke cycle, in-line diesel engine			
Firing order (injection sequence)		1 - 3 - 2		1 - 3 - 4 - 2	
Compression ratio		22			
Combustion chamber, type		Swirl			
Weight, kg (lb)		125 (276)		150 (331)	
No. of cylinders		3		4	
Bore x Stroke, mm (in.)		78 x 78.5 (3.07 x 3.09)	78 x 92 (3.07 x 3.62)	78 x 78.5 (3.07 x 3.09)	78 x 92 (3.07 x 3.62)
Displacement, liter (cu in.)		1.125 (68.7)	1.318 (80.4)	1.500 (91.5)	1.758 (107.3)
Fuel system	Injection pump, type	Bosch M			
	Injection nozzle, type	Throttle			
	Governor, type	Centrifugal flyweight			
	Fuel	ASTM No. 2-D			
Lubrication system	Type	Force feed (by trochoid pump)			
	Engine oil	API Service Classification CD			
	Oil filter	Paper-element (full-flow)			
	Capacity (high level excl. 0.5 liter (0.13 U.S. gal) of oil in oil filter), liter (U.S. gal)	5.7 (1.5) (with deep oil pan) 3.7 (1.0) (with standard oil pan)		7.7 (2.0) (with deep oil pan) 5.4 (1.4) (with standard oil pan)	
Cooling system	Type	Forced cooling			
	Capacity (approximate), liter (U.S. gal)	1.8 (0.5)		2.5 (0.7)	
Starter, V - kW		12 - 1.7		12 - 2.0	
Alternator, V - A		12 - 50			

GENERAL INFORMATION

PERFORMANCE CURVES (ONE-HOUR RATING, WITH FAN)

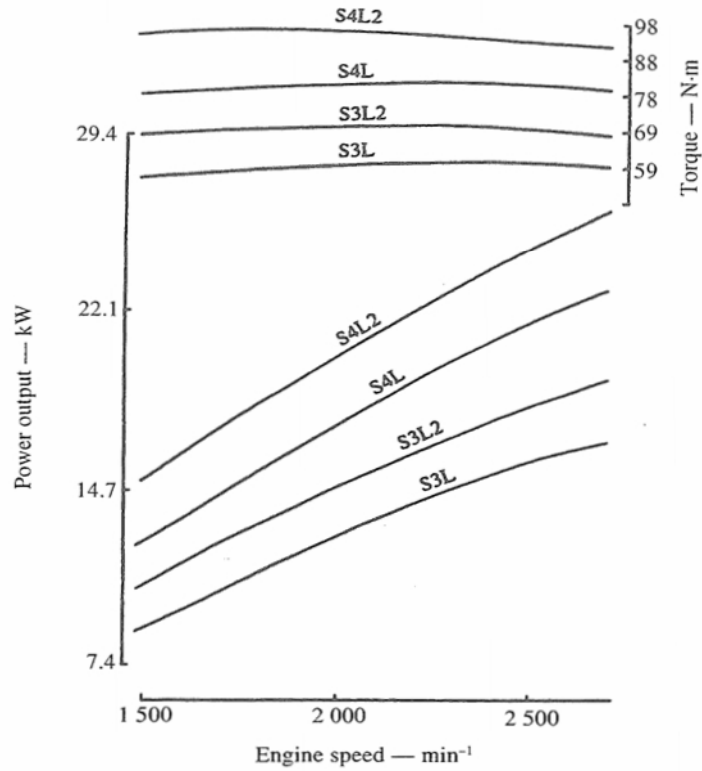

PRIME POWER OUTPUT CHART

Unit: kW

Rating	Engine model min ⁻¹	S3L	S3L2	S4L	S4L2
		With fan	With fan	With fan	With fan
One-hour (no overload)	1 500	8.8	10.7	12.5	15.1
	1 800	11.0	13.2	15.4	18.4
	2 000	12.5	14.7	17.3	20.2
	2 200	14.0	16.2	19.1	22.1
	2 500	15.8	18.0	21.3	24.6
Continuous	1 500	8.4	10.1	11.9	14.3
	1 800	10.5	12.6	14.7	17.5
	2 000	11.9	14.0	16.4	19.2
	2 200	13.3	15.4	18.2	21.0
	2 500	15.0	17.1	20.3	23.4

OVERHAUL INSTRUCTIONS

DETERMINING WHEN TO OVERHAUL THE ENGINE	8
COMPRESSION PRESSURE MEASUREMENT	
1. Inspection	9
2. Measurement	9
TROUBLESHOOTING	
1. General	10
2. Engine troubleshooting	
Problem 1: Hard starting	11
Problem 2: Fuel knock	12
Problem 3: Overheating	13
Problem 4: Black exhaust smoke	14
Problem 5: Erratic idle speeds	14
Problem 6: Low power or loss of power	15
3. Starting system troubleshooting	16
BASIC PRECAUTIONS FOR DISASSEMBLY AND ASSEMBLY	18
1. Disassembly	18
2. Assembly	18



Suggest:

For more complete manuals. Please go to the home page.

<https://www.ebooklibonline.com>

If the above button click is invalid. Please download this document first, and then click the above link to download the complete manual.

Thank you so much for reading

DETERMINING WHEN TO OVERHAUL THE ENGINE

Generally, when to overhaul the engine is to be determined by taking into account a drop in compression pressure as well as an increase in lube oil consumption and excessive blowby gases.

Lower power or loss of power, an increase in fuel consumption, a drop in lube oil pressure, hard starting and excessive abnormal noise are also troubles. These troubles, however, are not always the result of low compression pressure and give no valid reason for overhauling the engine.

The engine develops troubles of widely different varieties when the compression pressure drops in it. Following are the typical troubles caused by the compression pressure failure:

- (1) Low power or loss of power
- (2) Increase in fuel consumption
- (3) Increase in lube oil consumption
- (4) Excessive blowby through breather due to worn cylinders, pistons, etc.
- (5) Excessive blowby due to poor seating of worn inlet and exhaust valves
- (6) Hard starting or failure to start
- (7) Excessive engine noise

In most cases, these troubles occur concurrently. Some of them are directly caused by low compression pressure, but others are not. Among the troubles listed above, (2) and (6) are caused by a fuel injection pump improperly adjusted with respect to injection quantity or injection timing, worn injection pump plungers, faulty injection nozzles, or poor care of the battery, starter and alternator.

The trouble to be taken into account as the most valid reason for overhauling the engine is (4): in actually determining when to overhaul the engine, it is reasonable to take this trouble into account in conjunction with the other ones.

COMPRESSION PRESSURE MEASUREMENT

1. Inspection

Check to make sure —

- (1) The crankcase oil level is correct, and the air cleaner, starter and battery are all in normal condition.
- (2) The engine is at the normal operating temperature.

2. Measurement

- (1) Move the control lever to a position for shutting off fuel supply.
- (2) Remove all glow plugs from the engine. Install the compression gauge and adaptor (ST332270) combination to a cylinder on which the compression pressure is to be measured.
- (3) Turn the engine with the starter and read the gauge pressure at the instant the gauge pointer comes to stop.
- (4) If the gauge reading is below the limit, overhaul the engine.

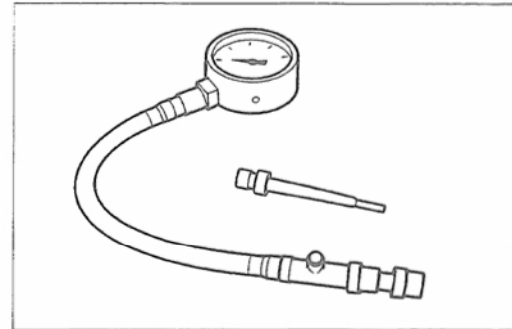

Compression gauge and adaptor

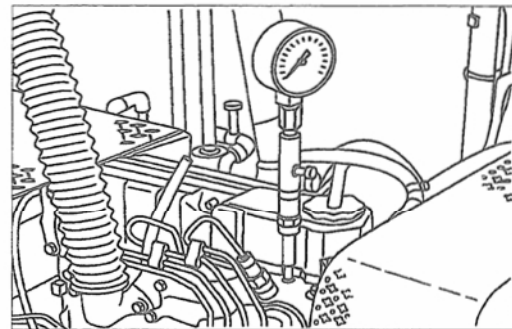

Measuring compression pressure

CAUTION

- a) Be sure to measure the compression pressure on all cylinders.
- b) The compression pressure varies with change of engine rpm. This makes it necessary to check engine rpm at the time of measuring the compression pressure.

CAUTION

- a) It is important to measure the compression pressure at regular intervals to obtain the data on the gradual change of the compression pressure.
- b) The compression pressure would be slightly higher than the standard in a new or overhauled engine owing to breaking-in of the piston rings, valve seats, etc. It drops as the engine components wear down.

Item	Standard		Limit
Engine speed, rpm	290		—
Compression pressure, kgf/cm ² (psi) [kPa]	SL	30 (427) [2 942]	23 (327) [2 256]
	SL2	32 (455) [3 138]	25 (356) [2 452]
Maximum permissible difference between average compression pressure of all cylinders in one engine. kgf/cm ² (psi) [kPa]	3 (42.7) [294]		—

<https://www.ebooklibonline.com>

Hello dear friend!

Thank you very much for reading.

Enter the link into your browser.

The full manual is available for immediate download.

<https://www.ebooklibonline.com>