



MDF1411A

# JXU75 - JXU85 - JXU95 JXU105 - JXU115

## TRACTORS SERVICE MANUAL

### SECTIONS

<b>GENERAL GUIDELINES</b> .....	<b>00</b>
<b>ENGINE</b> .....	<b>10</b>
<b>CLUTCH</b> .....	<b>18</b>
<b>TRANSMISSIONS</b> .....	<b>21</b>
<b>DRIVE LINES</b> .....	<b>23</b>
<b>FRONT MECHANICAL TRANSMISSION</b> .....	<b>25</b>
<b>REAR MECHANICAL TRANSMISSION</b> .....	<b>27</b>
<b>POWER TAKE-OFF</b> .....	<b>31</b>
<b>BRAKES</b> .....	<b>33</b>
<b>HYDRAULIC SYSTEMS</b> .....	<b>35</b>
<b>STEERING</b> .....	<b>41</b>
<b>AXLE AND WHEELS</b> .....	<b>44</b>
<b>CAB AIR CONDITIONING SYSTEM</b> .....	<b>50</b>
<b>ELECTRICAL SYSTEM</b> .....	<b>55</b>
<b>PLATFORM, CAB, BODYWORK</b> .....	<b>90</b>

S E R V I C E

**CONTENTS VOLUME 1**

	Page	Date		Page	Date
<b>00 - GENERAL GUIDELINES</b>			Checks and measurements - clutch .....	7-8	12-07
General instructions .....	1-2	12-07	Adjustments - clutch pedal	9	02-08
Safety regulations .....	3-4-5	12-07	Removal-Installation - clutch .....	10-12	12-07
Tractor refuelling .....	6	02-10	Clutch Overhaul .....	13-16	12-07
			Adjustments - clutch disengagement levers .....	17	12-07
<b>10 - ENGINE</b>			<b>21 - TRANSMISSIONS</b>		
Summary .....	1	02-10	<b>CHAPTER 1 - Reverser</b>		
General specifications ....	2-4	02-10	Summary .....	1	12-07
Fuel system data .....	5	02-10	Main Data .....	2	12-07
Torque Specifications ....	6-8	12-07	Transmission diagrams ...	3	12-07
Special Tools .....	9	12-07	Torque Specifications ....	4	12-07
View of 4-cylinder engine	10	12-07	Special Tools .....	5	12-07
Fault diagnosis .....	11-14	12-07	Sections .....	5-6	12-07
Engine removal-installation .....	15-32	12-07	Description and operation .	7	12-07
Replacing crankshaft front seal .....	33-35	12-07	Fault diagnosis .....	7-8	12-07
Replacing crankshaft rear seal .....	36-38	12-07	Disassembly-Assembly - reverser-clutch casing ...	8-12	12-07
Adjusting tappet, valve and rocker arm clearance ....	39-41	12-07	Transmission longitudinal cutaway section view ....	13-14	12-07
Removal-Installation - injectors .....	42-44	12-07	<b>CHAPTER 2 - Reverser and creeper unit</b>		
Removal - Installation - Bosch injection pump ....	45-49	12-07	Summary .....	1	12-07
Injection pump, renewal and checking timing .....	50-54	02-10	Main Data .....	2	12-07
Bosch injection pump - air bleeding .....	54	12-07	Transmission diagrams ...	3	12-07
Removal-Installation - coolant pump .....	55-56	12-07	Tightening torque .....	4	12-07
Removal-Installation - thermostat valve .....	57-58	12-07	Special Tools .....	5-6	12-07
Removal-Installation - radiator .....	59-65	12-07	Sections .....	7-8	12-07
Coolant pump drive belt adjustment .....	66-67	12-07	Description and operation	9	12-07
			Fault diagnosis .....	9	12-07
<b>18 - CLUTCH</b>			Replacing clutch casing-reverser and creeper unit .	10-15	12-07
Summary .....	1	12-07	End float adjustment between shaft and support ..	16-17	12-07
Main Data .....	2	12-07	Transmission longitudinal cutaway section view ....	18	12-07
Torque Specifications ....	3	12-07	<b>CHAPTER 3 - Power Shuttle Transmission (12X12)</b>		
Special Tools .....	3	12-07	Summary .....	1	12-07
Sections .....	4-5	02-10	Main Data .....	2-3	12-07
Fault diagnosis .....	6	12-07			

	Page	Date		Page	Date
Transmission diagrams . . .	4	12-07	Disassembly-Assembly - clutch (A) and (B) . . . . .	42÷47	12-07
Tightening torque . . . . .	5-6	12-07	Calibrations . . . . .	48	12-07
Special Tools . . . . .	7-8	12-07	HH MENU access . . . . .	48-49	12-07
Sections . . . . .	9÷10	12-07	Clutch calibration H1 menu transmission . . . . .	50÷52	02-10
Description and operation .	11-12	12-07	Transmission fault codes .	53÷55	02-10
Hydraulics . . . . .	13÷16	12-07	Transmission longitudinal cutaway section view . . . .	56	12-07
Range and gear lever posi- tion sensor adjustment	17-18	12-07			
Disassembly-Assembly - clutch casing with Power Shuttle units . . . . .	19÷23	12-07	<b>CHAPTER 5 - Power Shuttle transmission with creeper unit - 20X20 version</b>		
Disassembly-Assembly - driving shaft . . . . .	24-25	12-07	Summary . . . . .	1	02-10
Disassembly-Assembly - clutch (A) and (B) . . . . .	25÷32	12-07	Main Data . . . . .	2-3	02-10
Calibrations . . . . .	33	12-07	Transmission diagrams . . .	4	02-10
HH MENU access . . . . .	33-34	12-07	Tightening torque . . . . .	5-6	02-10
Clutch calibration H1 menu transmission . . . . .	35÷37	02-10	Special Tools . . . . .	7-8	02-10
Transmission fault codes .	38÷40	02-10	Sections . . . . .	9÷11	02-10
Transmission longitudinal cutaway section view . . . .	41	12-07	Description and operation .	12	02-10
			Creeper unit troubleshoot- ing . . . . .	13	02-10
<b>CHAPTER 4 - Power Shuttle transmission with dual command (2 speed power shift) function</b>			Disassembly-Assembly - clutch casing with Power Shuttle and creeper units .	14÷17	02-10
Summary . . . . .	1	12-07	Calibrations . . . . .	18	02-10
Main Data . . . . .	2-3	12-07	HH MENU access . . . . .	18-19	02-10
Transmission diagrams . . .	4	12-07	Clutch calibration H1 menu transmission . . . . .	20÷22	02-10
Tightening torque . . . . .	5-6	12-07	Transmission fault codes .	23÷25	02-10
Special Tools . . . . .	7-8	12-07			
Sections . . . . .	9÷11	12-07	<b>23 - DRIVE LINES</b>		
Description and operation .	12÷18	12-07	Summary . . . . .	1	12-07
Range and gear lever posi- tion sensor adjustment . . .	19-20	12-07	Main Data . . . . .	2	12-07
Removal-Installation - clutch casing with Power Shuttle and Dual Command (2 Speed Power Shift) units	21÷29	12-07	Torque Specifications . . . .	3	12-07
Disassembly-Assembly - clutch casing with Power Shuttle and Dual Command (2 Speed Power Shift) units	30÷36	12-07	Special Tools . . . . .	3	12-07
Disassembly-Assembly - driving shaft . . . . .	37-38	12-07	Sections . . . . .	4	12-07
Disassembly-Assembly - driven shaft . . . . .	39÷41	12-07	Description and operation .	5	12-07
			Fault diagnosis . . . . .	6	12-07
			Removal-Installation - ser- vices control valve . . . . .	7÷9	12-07
			Disassembly-Assembly - services control valve . . . .	10÷11	12-07
			Removal-Installation - drive gear casing . . . . .	12÷16	12-07

**<https://www.ebooklibonline.com>**

Hello dear friend!

Thank you very much for reading.

Enter the link into your browser.

The full manual is available for immediate download.

**<https://www.ebooklibonline.com>**

	Page	Date		Page	Date
Disassembly-Assembly - drive gear casing .....	17÷20	12-07	Disassembly-Assembly - transmission-gearbox casing .....	35÷42	12-07
<b>25 - FRONT AXLE MECHANICAL TRANSMISSION</b>					
Summary .....	1	12-07	Gearbox driving shaft end float adjustment .....	43	12-07
Main Data .....	2÷4	12-07	Adjustments - differential lock engagement sleeve position .....	44	12-07
Torque Specifications ....	5÷7	12-07	Determining the bevel pin- ion positioning adjustment ring .....	45-46	12-07
Special Tools .....	8-9	02-08	Tapered roller bearings adjustment for pinion shaft	47	12-07
Sections .....	10÷14	12-07	Adjusting the bevel crown wheel bearings and check- ing the clearance between the sides of the bevel drive teeth .....	48÷50	02-10
Description and operation .	15-16	12-07	Adjusting the preloading on the bevel drive bearings .	51-52	02-10
Fault diagnosis .....	17	12-07	Differential pinion and side gear backlash adjustment .	53-54	02-10
Rules for correctly fitting the axle support to the engine	18	12-07	Differential lock pedal travel adjustment .....	55	12-07
Removal-Installation - front axle .....	19÷22	12-07	Removal-Installation - fi- nal drive .....	56÷59	12-07
Disassembly-Assembly - front axle .....	23÷31	12-07	Disassembly-Assembly - epicyclic final drive .....	59	12-07
Overhaul - front differential	32	12-07	Disassembly-Assembly - drive wheel shaft .....	60-61	12-07
Overhaul - front axle differ- ential with LIM-SLIP .....	33-34	12-07	<b>31 - POWER TAKE-OFF</b>		
Overhaul - differential lock unit .....	35-36	12-07	<b>CHAPTER 1 - Mechanical power take-off</b>		
Disassembly-Assembly - front epicyclic final drive without brake .....	37÷40	12-07	Summary .....	1	12-07
Disassembly-Assembly - front epicyclic final drive with brake .....	41÷43	12-07	Main Data .....	2-3	12-07
Replacing wheel hub seal with brake .....	44	12-07	Special Tools .....	3	12-07
Stub axle adjustments ....	45-46	12-07	Torque Specifications ....	4	12-07
Adjustments - bevel drive	47÷51	12-07	Sections .....	5÷9	12-07
<b>27 - REAR MECHANICAL TRANSMISSION</b>			Description and operation .	10-11	12-07
Summary .....	1	12-07	Fault diagnosis .....	11	12-07
Main Data .....	2÷4	02-10	Fitting cooler with mechani- cal transmission and power take-off .....	12-13	12-07
Torque Specifications ....	5-6	12-07	Cooling system description and operation .....	14	12-07
Special Tools .....	7÷11	12-07	Removal-Installation - power take-off .....	15÷17	12-07
Sections .....	12÷17	02-10			
Description and operation .	18	02-10			
Fault diagnosis .....	19-20	12-07			
Removal-Installation - transmission-gearbox casing .....	21÷34	12-07			

	Page	Date		Page	Date
Disassembly-Assembly - power take-off .....	18÷20	12-07	Service brake circuit air bleeding .....	14-15	12-07
<b>CHAPTER 2 - Mechanical power take-off</b>			Removal-Installation - service brake pump .....	16-17	12-07
Summary .....	1	02-10	Adjusting the height of the service brake pedals .....	17	12-07
Main Data .....	2-4	02-10	Removal-Installation - service brake .....	18÷22	12-07
Special Tools .....	5	12-07	<b>CHAPTER 2 - Trailer air brakes (Italian and German version)</b>		
Torque Specifications ....	6	12-07	Summary .....	1	02-08
Sections .....	7÷14	12-07	Main Data .....	1	02-08
Description and operation .	15÷24	12-07	Torque Specifications ....	2	02-08
Additional PTO controls for cab-version tractors with Power Shuttle transmis- sions .....	25-26	02-10	Special Tools .....	2	02-08
Rear PTO fault code listing	26	02-10	Sections .....	3÷7	02-08
Fault diagnosis .....	27	12-07	Description and operation .	8-9	02-08
Replacing the power take- off brake .....	28-29	12-07	Operation of single trailer brake circuit components .	10÷16	02-08
Removal-Installation - power take-off .....	30÷33	12-07	Fault diagnosis .....	17	02-08
Disassembly-Assembly - power take-off .....	34÷40	12-07	Pressure tests .....	18÷22	02-08
Fitting cooler with mechani- cal transmission and elec- tro-hydraulic power take- off .....	41-42	12-07	<b>35 - HYDRAULIC SYSTEMS</b>		
Cooling system description and operation .....	43	12-07	<b>CHAPTER 1 - Rear mechanical hydraulic lift</b>		
<b>33 - BRAKES</b>			Summary .....	1	12-07
<b>CHAPTER 1 - Brakes</b>			Main Data .....	2÷6	02-10
Summary .....	1	12-07	Torque Specifications ....	7-8	12-07
Main Data .....	2	12-07	Special Tools .....	9	12-07
Torque Specifications ....	3	02-10	Sections .....	10-11	12-07
Sections .....	4-5	12-07	Description and operation .	12÷15	12-07
Description and operation .	6	12-07	Fault diagnosis .....	16-17	12-07
Hydraulic diagram - brakes .....	7	12-07	Hydraulic lift pump compo- nents .....	18-19	12-07
Pilot valve operation .....	8	12-07	Replacing the set of pump seals .....	19	12-07
Fault diagnosis .....	9	12-07	Disassembly-Assembly - LIFT-O-MATIC control ...	20	12-07
Adjustments - parking handbrake travel .....	10	12-07	Adjustments - lift rod mechanism .....	21-22	12-07
Removal-Installation/Dis- assembly-Assembly park- ing brake casing .....	11÷13	12-07	LIFT-O-MATIC device up- ward travel adjustment ...	23	02-08
			Disassembly-Assembly - external lift controls .....	24	02-08
			Removal-Installation - lift .	25÷31	12-07
			Disassembly-Assembly - lift .....	32÷36	12-07

	Page	Date		Page	Date
Adjusting the lift . . . . .	37÷42	12-07	<b>CHAPTER 4 - Trailer brakes auxiliary control valves</b>		
Removal-Installation - lift control valve . . . . .	43-44	12-07	Summary . . . . .	1	12-07
Disassembly-Assembly - lift control valve . . . . .	45÷49	12-07	Sections . . . . .	1	12-07
Lift pressure relief valve - removal/installation and setting . . . . .	50	02-10	Description and operation .	1÷5	12-07
			Operating diagrams . . . . .	6÷9	02-08
			Fault diagnosis . . . . .	10÷12	12-07
<b>CHAPTER 2 - Open centre system auxiliary control valves</b>			<b>CHAPTER 5 - Supplementary Cylinder</b>		
Summary . . . . .	1	12-07	Summary . . . . .	1	12-07
Main Data . . . . .	1	12-07	Main Data . . . . .	1	12-07
Special Tools . . . . .	1	12-07	Sections . . . . .	1	12-07
Torque Specifications . . . . .	2	12-07	Description and operation .	1	12-07
Sections . . . . .	3÷5	12-07	Removal-Installation/Disassembly-Assembly - supplementary cylinder . . . . .	2	12-07
Description and operation .	6÷9	12-07			
Disassembly-Assembly - auxiliary control valves . . . . .	10-11	12-07			
Rod hardening test . . . . .	11	12-07			
Blow-by test . . . . .	12	12-07			
Adjustment of the automatic detent release pressure . . . . .	12	12-07			
<b>CHAPTER 3 - Auxiliary control valves (BOSCH)</b>					
Summary . . . . .	1	12-07			
Main Data . . . . .	2	12-07			
Special Tools . . . . .	2	12-07			
Torque Specifications . . . . .	3	12-07			
View of BOSCH auxiliary control valve components . . . . .	4	12-07			
Description and operation .	4-5	12-07			
Control valve components	6÷9	12-07			
Description and operation - Hydraulic system . . . . .	10÷18	12-07			
Removal-Installation - BOSCH auxiliary control valves . . . . .	19÷21	12-07			
Disassembly-Assembly - BOSCH auxiliary control valves . . . . .	22÷26	12-07			
Quick coupler maintenance	27-28	12-07			
Fault diagnosis . . . . .	29-30	12-07			



## GENERAL INSTRUCTIONS

### IMPORTANT NOTICE

All maintenance and repair work described in this manual must be performed exclusively by CASE IH service technicians, in strict accordance with the instructions given and using any specific tools necessary.

Anyone performing the operations described herein without strictly following the instructions is personally responsible for any eventual injury or damage to property.

### SHIMMING

For each adjustment operation, select adjusting shims and measure individually using a micrometer, then add up the recorder values: Do not rely on measuring the entire shimming set, which may be incorrect, or the rated value indicated for each on shim.

### ROTATING SHAFT SEALS

For correct rotating shaft seal installation, proceed as follows:

- before assembly, allow the seal to soak in the oil it will be sealing for at least thirty minutes;
- thoroughly clean the shaft and check that the working surface on the shaft is not damaged;
- position the sealing lip facing the fluid; with hydrodynamic lips, take into consideration the shaft rotation direction and position the grooves so that they will deviate the fluid towards the inner side of the seal;
- coat the sealing lip with a thin layer of lubricant (use oil rather than grease) and fill the gap between the sealing lip and the dust lip on double lip seals with grease;
- insert the seal in its seat and press down using a flat punch; do not tap the seal with a hammer or mallet;
- whilst inserting the seal, check that it is perpendicular to the seat; once settled, make sure that it makes contact with the thrust element, if required;
- to prevent damaging the seal lip on the shaft, position a protective guard during installation operations.

### O-RING SEALS

Lubricate the O-RING seals before inserting them in the seats, this will prevent them from overturning and twisting, which would jeopardise sealing efficiency.

### SEALING COMPOUNDS

Apply one of the following sealing compounds on the mating surfaces marked with an X: RTV SILMATE, RHODORSIL CAF 1 or LOCTITE PLASTIC GASKET.

Before applying the sealing compound, prepare the surfaces as follows:

- remove any incrustations using a wire brush;
- thoroughly de-grease the surfaces using one of the following cleaning agents: trichlorethylene, petrol or a water and soda solution.

## BEARINGS

When installing bearings it is advised to:

- heat the bearings to 80 ÷ 90 °C before fitting on the shafts;
- allow the bearings to cool before installing them.

## SPRING PINS

When fitting split socket elastic pins, ensure that the pin notch is positioned in the direction of the force required to stress the pin.

Spiral spring pins do not require special positioning.

## SPARE PARTS

Use solely **genuine parts**, which guarantee the same quality, duration and safety as the original parts as they are identical to the ones fitted during production.

Only **genuine parts** can offer this guarantee.

When ordering spare parts, always provide the following information:

- tractor model (commercial name) and frame number;
- engine type and number;
- part number of the ordered part, which can be found in the "Microfiches" or the "Spare Parts Catalogue", used for order processing.

## NOTES FOR EQUIPMENT

The tools that CASE IH propose and illustrate in this manual are:

- specifically researched and designed for use with CASE IH vehicles;
- necessary to make reliable repair;
- accurately built and strictly tested to offer efficient and long-lasting working means.

By using these tools, repair personnel will benefit from:

- operating in optimal technical conditions;
- obtaining the best results;
- saving time and effort;
- working in safe conditions.

## IMPORTANT NOTES

Wear limit values indicated for certain parts are recommended, but not binding. The terms "front", "rear", "right-hand" and "left-hand" (when referred to different parts) are intended as seen from the driving position with the tractor in the normal direction of movement.

## MOVING THE TRACTOR WITH THE BATTERY REMOVED

External power supply cables should only be connected to the respective positive and negative cable terminals, using efficient clamps that guarantee adequate and secure contact.

Disconnect all services (lights, windshield wipers, etc.) before starting the vehicle.

If the vehicle electrical system requires checking, carry out operations with the power supply connected; Once checking is completed, disconnect all services and switch off the power supply before disconnecting the cables.

## SAFETY REGULATIONS

### WARNING AND DANGER SYMBOL



*This warning symbol points out important messages concerning your safety.*

*Carefully read the following safety regulations and observe advised precautions in order to avoid potential hazards and safeguard your health and safety.*

*In this manual the symbol is accompanied by the following key-words:*

**WARNING** - Warnings concerning unsuitable repair operations that may jeopardise the safety of Repair personnel.

**DANGER** - Specific warnings concerning potential hazards for operator safety or for other persons directly or indirectly involved.



### TO PREVENT ACCIDENTS

Most accidents or injuries that occur in workshops are the result of non-observance of simple and fundamental safety regulations.

For this reason, IN MOST CASES THESE ACCIDENTS CAN BE AVOIDED: by foreseeing possible causes and consequently acting with the necessary caution and care.

Accidents may occur with all types of vehicle, regardless of how well it was designed and built.

A careful and judicious service technician is the best guarantee against accidents.

Precise observance of the most basic safety rule is normally sufficient to avoid many serious accidents.

**DANGER.** Never carry out any cleaning, lubrication or maintenance operations when the engine is running.

### SAFETY REGULATIONS

#### GENERAL

- Carefully follow specified repair and maintenance procedures.
- Do not wear rings, wristwatches, jewellery, unbuttoned or loose articles of clothing such as: ties, torn clothing, scarves, open jackets or shirts with open zips that may remain entangled in moving parts.

It is advised to wear approved safety clothing, e.g: non-slip footwear, gloves, safety goggles, helmets, etc.

- Do not carry out repair operations with someone sitting in the driver's seat, unless the person is a trained technician who is assisting with the operation in question.
- Operate the vehicle and use the implements exclusively from the driver's seat.
- Do not carry out operations on the vehicle with the engine running, unless specifically indicated.
- Stop the engine and ensure that all pressure is relieved from hydraulic circuits before removing caps, covers, valves, etc.
- All repair and maintenance operations must be carried out using extreme care and attention.
- Service steps and platforms used in a workshop or in the field should be built in compliance with the safety rules in force.
- Disconnect the batteries and label all controls to indicate that the vehicle is being serviced. Block the machine and all equipment which should be raised.
- Do not check or fill fuel tanks, accumulator batteries, nor use starting liquid when smoking or near naked flames, as these fluids are inflammable.
- Brakes are inoperative if manually released for repair or maintenance purposes.  
Use blocks or similar devices to secure the machine in these conditions.
- The fuel nozzle should always be in contact with the filling aperture. Maintain this position until filling operations are completed in order to avoid possible sparks caused by the accumulation of static electricity.

- Only use specified towing points for towing the tractor, connect parts carefully. Make sure that all pins and/or locks are secured in position before applying traction.  
Never remain near the towing bars, cables or chains that are operating under load.
- Transport vehicles that cannot be driven using a trailer or a low-loading platform trolley, if available.
- When loading or unloading the vehicle from the trailer (or other means of transport), select a flat area capable of sustaining the trailer or truck wheels, firmly secure the tractor to the truck or trailer and lock the wheels in the position.
- Electric heaters, battery-chargers and similar equipment must only be powered by auxiliary power supplies with efficient ground insulation to avoid electrical shock hazards.
- Always use suitable hoisting or lifting devices when raising or moving heavy parts.
- Take extra care if bystanders are present.
- Never pour gasoline or diesel oil into open, wide and low containers.
- Never use gasoline, diesel oil or other inflammable liquids as cleaning agents. Use non-inflammable, non toxic commercially available solvents.
- Wear safety goggles with side guards when cleaning parts with compressed air.
- Limit the air pressure to a maximum of 2.1 bar, according to local regulations.
- Do not run the engine in confined spaces without suitable ventilation.
- Do not smoke, use naked flames, or cause sparks in the area when fuel filling or handling highly inflammable liquids.
- Never use naked flames for lighting when working on the machine or checking for leaks.
- All movements must be carried out carefully when working under, on or near the vehicle and wear protective equipment: helmets, goggles and special footwear.
- When carrying out checks with the engine running, request the assistance of an operator in the driver's seat. The operator must maintain visual contact with the service technician at all times.
- If operating outside the workshop, position the vehicle on a flat surface and lock in position. If working on a slope, lock the vehicle in position and move to a flat area as soon as is safely possible.
- Damaged or bent chains or cables are unreliable. Do not use them for lifting or towing.  
Always use suitable protective gloves when handling chains or cables.
- Chains should always be safely secured. Make sure that the hitch-up point is capable of sustaining the load in question.  
Keep the area near the hitch-up point, chains or cables free of all bystanders.
- Maintenance and repair operations must be carried out in a CLEAN and DRY area, eliminate any water or oil spillage immediately.
- Do not create piles of oil or grease-soaked rags as they represent a serious fire hazard; store them in a closed metal container.  
Before starting the vehicle or implements, make sure that the driver's seat is locked in position and always check that the area is free of persons or obstacles.
- Empty pockets of all objects that may fall unobserved into the vehicle parts when disassembled.
- In the presence of protruding metal parts, use protective goggles or goggles with side guards, helmets, special footwear and gloves.
- When welding, use protective safety devices: tinted safety goggles, helmets, special overalls, gloves and footwear. All persons present in the area where welding is taking place must wear tinted goggles.  
**NEVER LOOK DIRECTLY AT THE WELDING ARC WITHOUT SUITABLE EYE PROTECTION.**
- Metal cables tend to fray with repeated use. Always use suitable protective devices (gloves, goggles, etc.) when handling cables.
- Handle all parts carefully, do not put your hands or fingers between moving parts, wear suitable safety clothing - safety goggles, gloves and shoes.

## START UP

- Never start the engine in confined spaces that are not equipped with adequate ventilation for exhaust gas extraction.
- Never place the head, body, limbs, feet, hands or fingers near fans or rotating belts.

## ENGINE

- Always loosen the radiator cap slowly before removing it to allow any remaining pressure in the system to be discharged. Coolant should only be added when the engine is stopped or idling, if hot.
- Never fill up with fuel when the engine is running, especially if hot, in order to prevent the outbreak of fire as a result of fuel spillage.
- Never check or adjust fan belt tension when the engine is running.  
Never adjust the fuel injection pump when the vehicle is moving.
- Never lubricate the vehicle when the engine is running.

## ELECTRICAL SYSTEMS

- If it is necessary to use auxiliary batteries, remember that both ends of the cables must be connected as follows: (+) with (+) and (-) with (-).
- Avoid short-circuiting the terminals. **GAS RELEASED FROM BATTERIES IS HIGHLY INFLAMMABLE.**
- During charging, leave the battery compartment uncovered to improve ventilation.
- Never check the battery charge using "jumpers" (metal objects placed on the terminals).
- Avoid sparks or flames near the battery zone to prevent explosion hazards.
- Before servicing operations, check for fuel or current leaks: Eliminate any eventual leaks before starting work.
- Do not charge batteries in confined spaces: Make sure that there is adequate ventilation in order to prevent accidental explosion hazards as a result of the accumulation of gases released during charging operations.
- Always disconnect the battery before performing any kind of servicing on the electrical system.

## HYDRAULIC SYSTEMS

- A liquid leaking from a tiny hole may be almost invisible but, at the same time, be powerful enough to penetrate the skin. Check for leaks using a piece of cardboard, **NEVER USE HANDS.**

- If any liquid penetrates skin tissue, call for medical aid immediately
- Serious skin infections may result if medical attention is not given.
- Use the specific tools when checking pressure values on the hydraulic system.

## WHEELS AND TYRES

- Make sure that the tyres are correctly inflated at the pressure specified by the manufacturer.  
Periodically check the rims and tyres for damage.
- Stand away from (at the side of) the tyre when checking inflation pressure.
- Only check pressure when the vehicle is unloaded and the tyres are cold, to avoid incorrect readings as a result of over-pressure.
- Do not re-use parts of recovered wheels as incorrect welding or brazing may heat the material, causing it to weaken and eventually damage or break the wheel.
- Never cut or weld a rim mounted with an inflated tyre.
- When removing the wheels, lock both the front and rear vehicle wheels.
- Always position support stands when raising the vehicle, in order to conform to current safety regulations.
- Deflate the tyre before removing any object caught in the tyre tread.
- Never inflate tyres using inflammable gases; this could cause an explosion and put operator safety at risk.

## REMOVAL AND RE-FITTING

- Lift and handle all heavy parts using suitable lifting equipment and make sure that all slings and hooks are correctly secured.
- Handle all parts carefully during lifting operations, keep an eye on the personnel working near the load to be lifted. Never insert hands or fingers between parts, always wear approved accident prevention clothing (goggles, gloves and work boots).
- Avoid twisting chains or metal cables and always wear safety gloves when handling cables or chains.

## CONSUMABLES

COMPONENT TO BE FILLED OR TOPPED UP	QUANTITY dm <sup>3</sup> (litres)	RECOMMENDED CASE IH PRODUCT	INTERNATIONAL SPECIFICATION
Cooling system: less cab: ..... with cab: .....	14 16	Water and <b>AKCELA PREMIUM ANTIFREEZE MS 1710</b> 50% + 50%	-
Windscreen wash reservoir .....	2	Water & cleaning liquid	-
Fuel tank - all models ..... - mod.: 71/97, 78/106 and 83/113 KW/CV (suppl. tank) .....	127 40	Decanted, filtered diesel fuel	-
Engine oil sump: without filter: ..... with filter: .....	8,9 9,5	<b>AKCELA No 1 ENGINE OIL MS 1121 SAE 15W-40</b> or MS 1121 SAE 10W-30	API CH-4 ACEA E5 SAE 15W-40 API CH-4 SAE 10W-30
Brake control circuit without front brakes .....	0,4	<b>AKCELA LHM FLUID</b>	ISO 7308
Front axle: axle housing: - all models ..... final drives (each): - with brakes ..... - without brakes .....	7,5 2,0 1.4	<b>AKCELA NEXPLORE</b> MAT 3525 fluid	API GL4 ISO 32/46 SAE 10W-30
Rear transmission (bevel drive, final drives and brakes), gearbox, hydraulic lift, PTO and power steering - Mech. transmissions ..... - Power shuttle .....	50 60		
Front hubs .....	-	<b>AKCELA MULTI-PURPOSE GREASE 251H EP</b>	NLGI 2
Grease fittings .....	-		
Antifreeze fluid reservoir for air brakes .....	0,5	Antifreeze for compressed air brake systems for low-temperature use (down to - 40 °C)	-

**SECTION 10 - ENGINE****Chapter 1 - Engine****CONTENTS**

<b>Description</b>	<b>Page</b>
General specifications .....	2
Torque Specifications .....	6
Special Tools .....	9
Engine view .....	10
Fault diagnosis .....	11
Engine R.I. ....	15
Crankshaft front seal - Replacement .....	33
Crankshaft rear seal - Replacement .....	36
Valve tappet and rocker arm clearance - Adjustment .....	39
Engine injector R.I. ....	42
Bosch injection pump R.I. Valve Timing. Air bleed .....	45
Coolant pump R.I. ....	55
Thermostat valve R.I. ....	57
Radiator R.I. ....	59
Coolant pump and generator drive belt. Tension adjustment .....	66

GENERAL SPECIFICATIONS	4-cylinder
Engine, technical type:	
- mod. 56/76 KW/HP .....	F4CE9484A*J600
- mod. 63/86 KW/HP .....	F4CE9484N*J601
- mod. 71/97 KW/HP .....	F4CE9484M*J601
- mod. 78/106 KW/HP .....	F4CE9484L*J600
- mod. 83/113 KW/HP .....	F4CE9484C*J600
Cycle .....	diesel, 4-stroke
Fuel injection .....	Direct
Number of cylinders in line .....	4
mod. 56/76, 63/86, 71/97, 78/106 and 83/113 KW/HP	
- Piston diameter .....	104 mm
- Piston stroke .....	132 mm
Total displacement:	
- mod. 56/76, 63/86, 71/97, 78/106 and 83/113 KW/HP ....	4485 cm <sup>3</sup>
Compression ratio	
- mod. 56/76, 63/86, 71/97, 78/106 and 83/113 KW/HP ....	16,5:1
Maximum Power Output:	
- mod. 56/76 KW/hp - type F4CE9484A*J600 .....	56 KW (76 hp)
- mod. 63/86 KW/hp - type F4CE9484N*J601 .....	63 kW (86 Hp)
- mod. 71/97 KW/hp - type F4CE9484M*J601 .....	71 kW (97 Hp)
- mod. 78/106 KW/hp - type F4CE9484L*J600 .....	78 KW (106 hp)
- mod. 83/113 KW/HP - type F4CE9484C*J600 .....	83 KW (113 hp)
Maximum power speed .....	2300 rpm
Maximum torque	
- mod. 56/76 KW/hp - type F4CE9484A*J600 .....	324 (Nm)
- mod. 63/86 KW/hp - type F4CE9484N*J601 .....	366 (Nm)
- mod. 71/97 KW/hp - type F4CE9484M*J601 .....	404 (Nm)
- mod. 78/106 KW/hp - type F4CE9484L*J600 .....	425 (Nm)
- mod. 83/113 KW/HP - type F4CE9484L*J600 .....	445 (Nm)
Maximum torque speed .....	1300 rpm
Number of main bearings .....	5
Sump pan .....	structural, cast iron

(continued)

(Continued)

GENERAL SPECIFICATIONS	4-cylinder
<b>Lube</b> ..... Pump drive ..... Engine speed/oil pump speed ratio ..... Oil filtration ..... Normal oil pressure with motor warmed-up: at slow idling ..... at fast idling .....	forced, with lobe pump Camshaft mesh screen on oil pick-up and filter cartridge in delivery line > 0.7 bar (> 0.71 Kg/cm <sup>2</sup> ) 3,1 ± 0,9 (3,16 ± 0,91)
<b>Cooling system</b> ..... Radiator on Mod. 56/76, 63/86, 71/97, 78/106 and 83/113 KW/HP ..... Fan, attached to the pulley ..... Coolant pump ..... Coolant thermometer ..... Temperature ranges corresponding to each section: - Initial blue section ..... - Middle green section (normal working conditions) ..... - red end section ..... Temperature control ..... - initial opening .....	coolant circulation three-row vertical pipes intake, in plastic with 10 blades centrifugal vane-type coloured scale divided into three sections 40° ÷ 60 °C 60° ÷ 110 °C 110° ÷ 120 °C via thermostat valve 81 ± 2 °C
<b>Timing</b> ..... Intake: - start: before T.D.C. .... - end: after B.D.C. .... Exhaust: - start: before B.D.C. .... - end: after T.D.C. .... Clearance between valves and rocker arms with engine cold: - intake ..... - exhaust .....	overhead valves operated by tappets, rods and rocker arms via the camshaft located in the engine block; the camshaft is driven by the crankshaft using straight-tooth gears 16° ± 30' 32° ± 30' 48° ± 30' 4° ± 30' 0.30 ± 0.05 mm 0.55 ± 0.05 mm

(continued)

(Continued)

GENERAL SPECIFICATIONS	4-cylinder
<p><b>Boost</b></p> <p>Turbocharger type:</p> <ul style="list-style-type: none"> <li>- Holset</li> </ul> <p>Air filter .....</p> <p>Charge Pump .....</p> <p>Fuel filtration .....</p> <p>Cam operated .....</p> <p>BOSCH pump .....</p> <p>All-speed governor, incorporated in pump:</p> <p>BOSCH .....</p> <p>Automatic advance regulator, incorporated in pump:</p> <p>BOSCH .....</p> <p>Fixed advance (pump setting on engine for start of delivery before TDC) .....</p>	<p>With intercooler</p> <p>HX25</p> <p>dual cartridge dry air filter, with clogged filter indicator with centrifugal pre-filter and automatic dust ejector</p> <p>with double diaphragm</p> <p>through wire filter in fuel supply pump, and replaceable cartridge on delivery line to injection pump</p> <p>via engine timing</p> <p>rotating distributor type</p> <p>centrifugal counterweights</p> <p>hydraulic</p> <p>refer to the data given in the table for operation 14 page 53</p>
<p><b>Filling</b></p> <p>Oil sump</p> <p>Engine sump + filter</p>	<p>8.9 litres</p> <p>9.5 litres</p>
<p><b>Anti-pollution system</b></p> <p>Type: .....</p>	<p>Exhaust gas recirculation system <b>EGR (*)</b></p>

(\*) Modification to the profile of the intake cam that permits partial opening of the valve simultaneously with the exhaust valve (exhaust gas recirculation EGR).

## FUEL SYSTEM DATA

Injection pump .....	rotating distributor with speed governor and advance variator incorporated
BOSCH pump:	
- mod. 56/76 KW/hp - type F4CE9484A*J600 .....	VE 4/12 F1150 L2042
- mod. 63/86 KW/hp - type F4CE9484N*J601 .....	VE 4/12 F1150 L2033
- mod. 71/97 KW/hp - type F4CE9484M*J601 .....	VE 4/12 F1150 L2029
- mod. 78/106 KW/hp - type F4CE9484L*J600 .....	VE 4/12 F1150 L2041
- mod. 83/1113 KW/HP - type F4CE9484C*J600 .....	VE 4/12 F1150 L___
Direction of rotation .....	anticlockwise
Injection order .....	1-3-4-2 (for all models)

	56/76 KW/hp	63/86 KW/hp	71/97 KW/hp	78/106 KW/hp	83/113 KW/hp
BOSCH-type injectors:	DSL A 145 P 1441				
- F4CE9484A*J600 .....					
- F4CE9484N*J601 .....					
- F4CE9484M*J601 .....					
- F4CE9484L*J600 .....					
- F4CE9484C*J600 .....					
Number of nozzle holes .....	6				
Nozzle hole diameter mm.	0,226				
- F4CE9484A*J600 .....					
- F4CE9484N*J601 .....					
- F4CE9484M*J601 .....					
- F4CE9484L*J600 .....					
- F4CE9484C*J600 .....					
Setting pressure bar (kg/cm <sup>2</sup> ) .....	260 ÷ 272 (265.13 ÷ 277.36)				

**NOTE:** For more information on the **engine** and overhauling, refer to the specific manual:  
document no° 87664161A for Italian  
document no° 87659057A for English  
document no° 87659058A for French  
document no° 87659059A for German  
document no° 87659060A for Spanish.

PARTS TO BE TIGHTENED	Thread	Tightening torque		
		Nm	kgm	kgm
Cooling nozzles .....	M 8X1.25X10	15 ± 3	1,5 ± 0,3	-
Main bearings:	-	-	-	-
1 <sup>st</sup> phase .....	-	50 ± 6	5,0 ± 0,6	-
2 <sup>nd</sup> phase .....	-	80 ± 6	8,0 ± 0,6	-
3 <sup>rd</sup> phase .....	-	-	-	90° ± 5°
Rear gearbox .....	M 8X1.25X40	24 ± 4	2,4 ± 0,4	-
	M 8X1.25X25	24 ± 4	2,4 ± 0,4	-
	M 10x1.5	49 ± 5	4,9 ± 0,5	-
Oil pump .....	M 8X1.25X30	8 ± 1	0,8 ± 0,1	-
Front box cover .....	M 8X1.25X45	24 ± 4	2,4 ± 0,4	-
	M 8X1.25X30	24 ± 4	2,4 ± 0,4	-
Big-end cap bolts:	-	-	-	-
1 <sup>st</sup> phase .....	M 11X1.25	30 ± 3	3,0 ± 0,3	-
2 <sup>nd</sup> phase .....	M 11X1.25	60 ± 5	6,0 ± 0,5	-
3 <sup>rd</sup> phase .....	M 11X1.25	-	-	60° ± 5°
Bracket assembly .....	M 10X1.25X25	43 ± 5	4,3 ± 0,5	-
Plugs on the cylinder block .....	M 10X1	6 ± 1	0,6 ± 0,1	-
	M 14x1.5	11 ± 2	1,1 ± 0,2	-
Oil inlet pipe assembly .....	M 8X1.25X20	24 ± 4	2,4 ± 0,4	-
Oil sump installation .....	M 8X1.25X25	24 ± 4	2,4 ± 0,4	-
	M 18x1.5	60 ± 9	6,0 ± 0,9	-
Timing system locking pin installation .....	M5 T25	5 ± 1	0,5 ± 0,1	-
Fuel pump installation .....	M8	24 ± 4	2,4 ± 0,4	-
	M6	10 ± 1	1,0 ± 0,1	-
Fuel pump retaining bolts:	-	-	-	-
pre-tightening .....	M 10x1.25	10÷15	1.0 ÷ 1.5	-
end torque .....	M 10x1.25	50÷55	5.0 ÷ 5.5	-
Fuel pump gear:	-	-	-	-
precision torque .....	Retaining nut	15÷20	1.5 ÷ 2.0	-
end torque .....	Retaining nut	85÷90	8.5 ÷ 9.0	-
Inspection cover on the gearbox .....	-	30÷35	3.0 ÷ 3.5	-
Fixing the rocker arm on the head .....	M8	24 ± 4	2,4 ± 0,4	-

(continued)

(overleaf)

Head retaining bolts (*):	-	-	-	-
1 <sup>st</sup> phase - 2 <sup>nd</sup> phase .....	M12X70	50	5.0	90°
1 <sup>st</sup> phase - 2 <sup>nd</sup> phase - 3 <sup>rd</sup> phase .....	M12X140	40	4.0	90° + 90°
1 <sup>st</sup> phase - 2 <sup>nd</sup> phase - 3 <sup>rd</sup> phase .....	M12X180	70	7.0	90° + 90°
Rocker arm covers .....	M8X1.25X65	24 ± 4	2.4 ± 0.4	-
Intake manifold fastening .....	M8X1.25	24 ± 4	2.4 ± 0.4	-
Air intake union assembly .....	M8X1.25	24 ± 4	2.4 ± 0.4	-
Oil by-pass valve fastening on the filter head .....	M22X1.5X10	80 ± 8	8.0 ± 0.8	-
Plug .....	M12X1.25X12	10 ± 1	1.0 ± 0.1	-
Exhaust manifold fastening .....	M10X1.25X65	43 ± 6	4.3 ± 0.6	-
Coolant pump fastening .....	M8X1.25X25	24 ± 4	2.4 ± 0.4	-
Coolant inlet connector assembly .....	M8X1.25X35	24 ± 4	2.4 ± 0.4	-
	M8X1.25X70	24 ± 4	2.4 ± 0.4	-
Fan hub fastening .....	M10X1.25X20	33 ± 5	3.3 ± 0.3	-
Fan pulley fastening .....	M6	10 ± 2	1.0 ± 0.2	-
	M10	43 ± 6	4.3 ± 0.6	-
Rear lifting bracket fastening .....	M12X1.75X30	77 ± 12	7.7 ± 1.2	-
Crankshaft pulley .....	M12X1.75 (10.9)	110 ± 5	11.0 ± 0.5	-
Flywheel casing fastening: .....	M12X120	85 ± 10	5.5 ± 1.0	-
	M12X70	85 ± 10	5.5 ± 1.0	-
	M12X140	49 ± 5	4.9 ± 0.5	-
	M12X180	49 ± 5	4.9 ± 0.5	-
Flywheel fastening on the crankshaft	-	-	-	-
1 <sup>st</sup> phase .....	M12X1.25	30 ± 4	3.0 ± 0.4	-
2 <sup>nd</sup> phase .....	M12X1.25	-	-	60° ± 5°
Inlet pump gear cover .....	M8X1.25X16	24 ± 4	2.4 ± 0.4	-
Fuel injectors .....	-	60 ± 5	6.0 ± 0.6	-
Fuel priming pump fastening .....	-	24 ± 4	2.4 ± 0.4	-
Turbo-blower / exhaust manifold fastening .....	M10	43 ± 6	4.3 ± 0.6	-
Oil inlet pipe / filter fastening .....	-	24 ± 4	2.4 ± 0.4	-
Lubrication piping / turbo-blower fastening .....	M12X1.5	35 ± 5	3.5 ± 0.5	-
Turbo-blower exhaust piping fastening .....	M8X1.25X16	24 ± 4	2.4 ± 0.4	-

(overleaf)

(overleaf)

Alternator fastening on its support .....	M8X1.25X30	24 ± 4	2.4 ± 0.4	-
Alternator support / thermostat cover fastening .....	M8X1.25X30	24 ± 4	2.4 ± 0.4	-
Alternator support / thermostat cover assembly .....	M8X1.25X30	24 ± 4	2.4 ± 0.4	-
Lower support assembly .....	M10X1.25X25	24 ± 4	2.4 ± 0.4	-
Fastening of the top of the alternator on the support ..	M10	49 ± 5	4.9 ± 0.5	-
Alternator support fastening .....	M12X1.75X120	43 ± 6	4.3 ± 0.6	-
Electrical connections on the alternator .....	M6X1	10 ± 2	1.0 ± 0.2	-
Starter motor / flywheel cover casing fastening .....	M10	49 ± 5	4.9 ± 0.5	-
Crankshaft cap retaining bolts:	-	-	-	-
1 <sup>st</sup> phase .....	M12	50 ± 6	5 ± 0.6	-
2 <sup>nd</sup> phase .....	M12	80 ± 6	8 ± 0.6	-
3 <sup>rd</sup> phase .....	M12	-	-	90° ± 5°
Camshaft longitudinal retaining plate fixing bolt .....	M8	24 ± 4	2.4 ± 0.4	-
Camshaft gear retaining bolt .....	M8	36 ± 4	3.6 ± 0.4	-
Connecting rod cap retaining bolt:	-	-	-	-
1 <sup>st</sup> phase .....	M11	60 ± 5	6 ± 0.5	-
2 <sup>nd</sup> phase .....	M11	-	-	60° ± 5°

(\*) To tighten the head, proceed as follows:

- 1<sup>st</sup> phase** of tightening with torque wrench:  
M12 x 1.75 x 70 bolt: 50 Nm ÷ 5 Nm  
(ref. 3-6-11-14)

M12 x 1.75 x 140 bolt: 40 Nm ÷ 5 Nm  
(ref. 1-2-7-8-9-10-15-16-17-18)

M12 x 1.75 x 180 bolt: 70 Nm ÷ 5 Nm  
(ref. 4-5-12-13)

- 2<sup>nd</sup> phase** tightening to an angle of 90° for all the screws.  
 **3<sup>rd</sup> stage** additional tightening to an angle of 90° for 140 and 180 mm long bolts only.

A = fan side

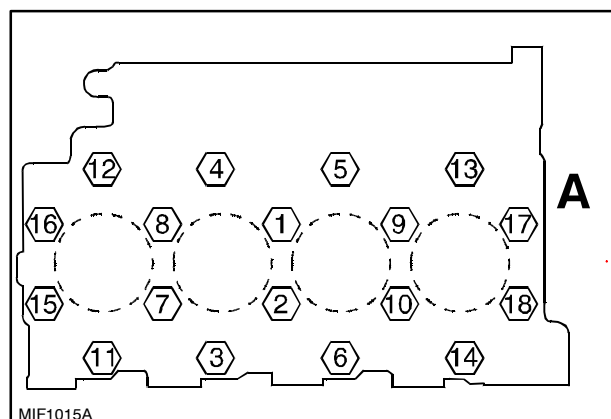

MIF1015A



**Suggest:**

**For more complete manuals. Please go to the home page.**

**<https://www.ebooklibonline.com>**

**If the above button click is invalid. Please download this document first, and then click the above link to download the complete manual.**

**Thank you so much for reading**

**SPECIAL TOOLS**

**Warning** - The operations described in this section can only be carried out with **ESSENTIAL** tools indicated by an (X).

To work safely and efficiently and obtain the best results, it is also necessary to use the recommended specific tools listed below and certain other tools, which are to be made according to the drawings included in this manual.

**List of specific tools required for the various operations described in this Section.**

X 380000216	Engine removal and installation tool.	X 380000664	Splining tool for fitting rear seal on crankshaft.
380000220	Clamp for fitting piston in cylinder liner (60-125 mm).	X 380000665	Tool to extract crankshaft front seal.
X 380000221	Pliers for piston ring disassembly and reassembly (65-110 mm).	X 380000666	Splining tool for fitting front seal on crankshaft.
380000301	Rotating stand for overhaul operations (capacity 1000 daN, torque 120 daN/m).	X 380000667	Drift for camshaft bushing disassembly and reassembly (use with 380000668).
X 380000302	Tool for engine valve disassembly and reassembly.	380000668	Grip for interchangeable drifts.
380000304	Pair of gauges for angular tightening with 1/2" and 3/4" square connection.	X 380000669	Gasket extraction tool.
380000362	Crankshaft lifting tool.	X 380000670	Tool for cartridge filter disassembly.
X 380000364	Dial gauge base for various measurements (use with 380000228).	380000671	Injector extraction tool.
380000569	Movable tool for dismantling tractors with bracket 380000500 and adapter plate 380000844.	380000975	Box with full set of tools to regrind valve seats.
X 380000661	Engine mounting brackets for rotating stand 380000301.	380000976	Spring load test appliance.
X 380000663	Tool to extract crankshaft rear seal.	380001003	Complete square to check for connecting rod distortion.
		380001268	Belt tension gauge.
		<b>Injection pump bench test.</b>	
		380000228	Dial gauge (0-5 mm).
		X 380000914	Dial-gauge holder tool for rotary injection pump timing (use with 380000228).
		X 380000732	Tool for engine flywheel rotation (use with 380000988).
		X 380000988	Plate for engine flywheel rotation tool with flywheel timing pin (use with 380000732).

ENGINE VIEW

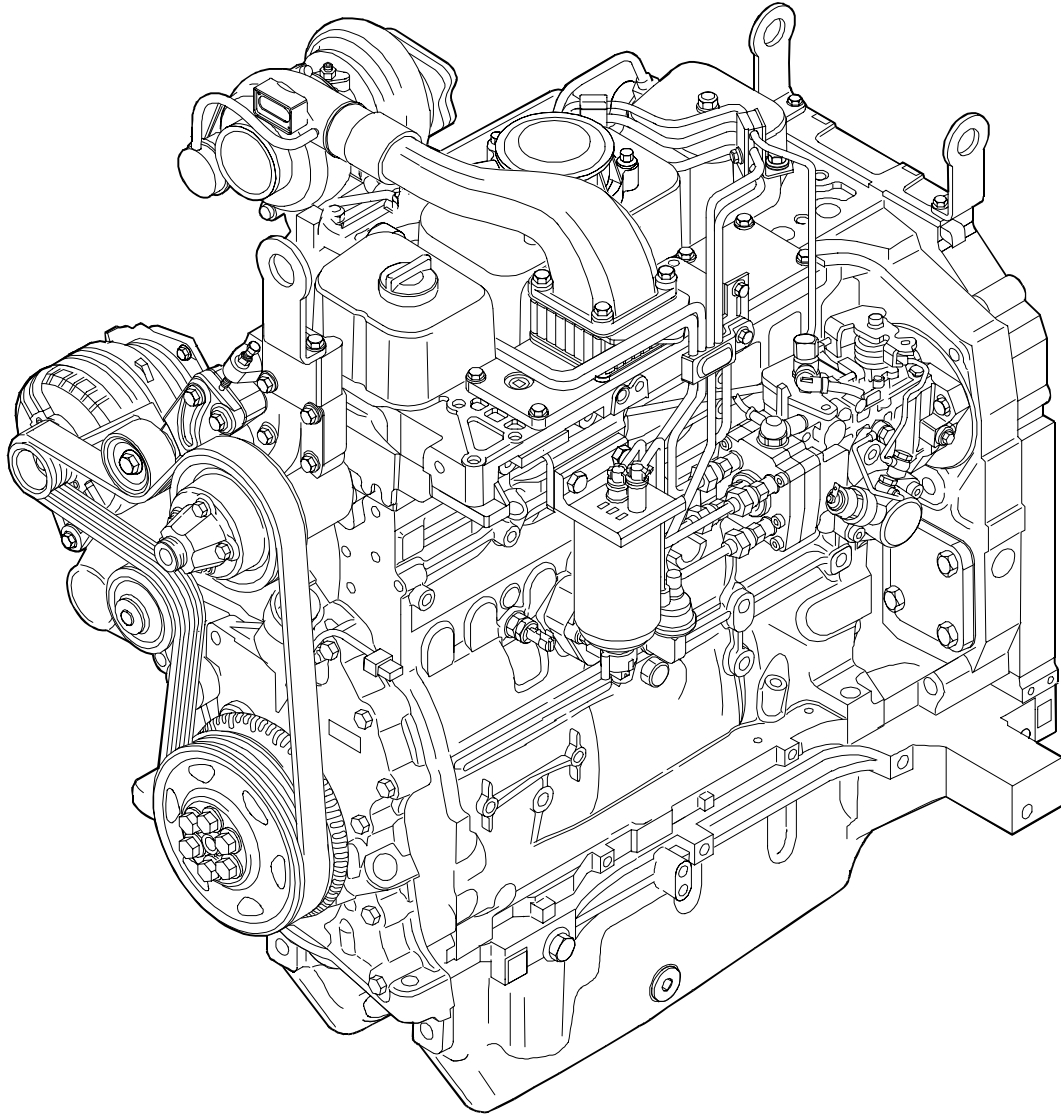

MIF1097A

**<https://www.ebooklibonline.com>**

Hello dear friend!

Thank you very much for reading.

Enter the link into your browser.

The full manual is available for immediate download.

**<https://www.ebooklibonline.com>**