

JX60 - JX70 - JX80 - JX90 - JX95 MODEL TRACTORS SERVICE MANUAL

SECTIONS	
GENERAL	00
ENGINE	10
CLUTCH	18
GEARBOX	21
TRANSMISSION OF MOTION	23
FRONT MECHANICAL TRANSMISSION	25
REAR MECHANICAL TRANSMISSION	27
POWER TAKE-OFF	31
BRAKES	33
HYDRAULIC SYSTEMS	35
STEERING	41
AXLE AND WHEELS	44
AUXILIARY EQUIPMENT	50
ELECTRICAL SYSTEM	55
CAB	90

S E R V I C E



Repair Manual - JX Series Tractors

CONTENTS

GENERAL

SECTION 00

General Instructions and Health and Safety

Chapter 1

Section	Description	Page
00 000	General instructions	1
	Notes for spare parts	2
	Notes for equipment	2
	Safety rules	3
	Consumables	6

ENGINE

SECTION 10

Engine System

Chapter 1

Section	Description	Page
10 000	General specification	2
	Injection pump calibration data	5
	General specifications	16
	Tightening torques	24
	Tools	25
	Cross-sectional views	28
	Lubrication and cooling system diagrams	32
	Fault diagnosis	35
10 001 10	Engine <i>Removal-Installation</i>	39
10 001 54	Engine <i>Bench overhaul</i>	53
	Checks, measurements and repairs	78
10 406 10	Radiator <i>Removal-Installation</i>	102
10 102 70	Crankshaft front oil seal <i>removal installation</i>	106
10 402 10	Coolant pump <i>removal installation</i>	112
10 402 30	Cooling system thermostat	115
10 206 14	Bosch injection pump <i>removal installation</i>	118
	Bosch injection pump <i>timing</i>	121
	Bosch injection pump <i>air bleeding</i>	123
10 218 30	Injectors <i>removal installation</i>	124
10 106 12	Valve clearance adjustment	126

10 402 28	Coolant pump overhaul	129
10 001 30	Compression test	130

CLUTCH

SECTION 18

Clutches

Chapter 1

Section	Description	Page
18 000	General specifications	1
	Tightening torques	2
	Tools	3
	Cross-sectional views	4
	Clutch Troubleshooting	5
18 110 10	Removal - Installation	6
	Overhaul	14
	Minimum permissible dimensions after refacing	18
	Adjustments	19
18 100 40	Adjustment of the main and PTO clutch control linkage	21

GEARBOX

SECTION 21

Mechanical Transmission (12x4)

Chapter 1

Section	Description	Page
21 000	Main data	1
	Tightening torques	2
	Tools	3
	Section views	3&5
	Description and operation	8
	Fault diagnosis	8
21 110	Removal - Refitting	see sect 27

Reverser (12x12)

Chapter 2

Section	Description	Page
21 000	Main data	1
	Tightening torques	2
	Tools	3
	Section views	3
	Description and operation	5
	Fault diagnosis	5
21 110	Removal-Refitting	6

Reverser and Creeper (20x12)

Chapter 3

Section	Description	Page
21 000	Main data	1
	Tightening torques	2
	Tools	3
	Section views	4
	Description and operation	6
	Fault diagnosis	6
21 110	Removal-Refitting	7

<https://www.ebooklibonline.com>

Hello dear friend!

Thank you very much for reading.

Enter the link into your browser.

The full manual is available for immediate download.

<https://www.ebooklibonline.com>

DRIVE LINES

SECTION 23

Drive Lines

Chapter 1

Section	Description	Page
23 000	Main specification	1
	Torque settings and Tools	2
	Cross-Sectional views	3
23 101 26	Transmission shafts and guard (Disassembly - Assembly)	4
23 101 40	Drive gear housing (Removal - Installation)	5
23 101 42	Drive gear housing removed (Disassembly - Assembly)	7

FRONT AXLE MECHANICAL TRANSMISSION

SECTION 25

Front Axle Mechanical Transmission

Chapter 1

Section	Description	Page
25 000	Main data	1
	Tightening torques	4
	Tools	6
	Cross-sectional views	7
	Description and operation	9
25 100 30	Complete front axle. Removal - Installation	10
25 100 38	Front axle. Removal - Installation	14
25 108 46-47	Steering knuckle bearing pins. Replacement	24
	Stub axle adjustment	25
	Wheel hub bearing adjustment	27
	Bevel drive adjustment	29
25 102 24	Front axle differential. Overhaul	36
25 100 27	Front axle differential with LIM-SLIP. Overhaul	37
	Front axle differential with NO SPIN. Overhaul	39
44 511 80	Leading drive wheels toe-in check	42

REAR AXLE AND TRANSMISSION

SECTION 27

Rear Axle And Transmission

Chapter 1

Section	Description	Page
27 000	Main data	1
	Tightening torques	3
	Special tools	5
	Cross-sectional views	7
	Description and operation and troubleshooting	9
21.118.10 - 12	Transmission-gearbox casing Removal-Installation	10
21.118.85	Transmission-gearbox casing Disassembly-Overhaul	27
	Gearbox driven shaft end float adjustment	35
	Differential lock engagement sleeve adjustment	36
	Determining the bevel pinion positioning adjustment ring	37
	Adjusting the taper roller bearings for the bevel pinion shaft	39
	Adjusting the bearings and checking the backlash	40
	Differential pinion and side gear backlash adjustment	44

POWER TAKE-OFF

SECTION 31

Mechanical Power Take - Off

Chapter 1

Section	Description	Page
31 000	Main specification	1
	Tools	3
	Torque settings	4
	Sectional drawings	5
	Description and operation	9
	Troubleshooting	10
	Removal - Refitting	11
31 101	Bench overhaul	14

BRAKING SYSTEM

SECTION 33

Braking System

Chapter 1

Section	Description	Page
33 000	Main data	1
	Tightening torques	2
	Cross-sectional views	2
	Description & Operation	9
	Tools - Troubleshooting	10
33.206	Front brake assembly mod. JX60 and JX70 removal and refitting - overhauling on the bench	11
33.202.60	Service brake removal and refitting	14
33.202.50	Removal-Refitting of front brake pumps	19
33.202.40	Bleeding air from the front braking system	23
33.120.08	Adjusting service brake pedals travel	24
33.110.08	Parking brake travel adjustment	24

HYDRAULIC SYSTEM

SECTION 35

Rear Mechanical Hydraulic Lift

Chapter 1

Section	Description	Page
35 000	Main specification	1
	Tightening torques	3
	Tools	6
	Cross-sectional views	7
	Description & Operation	9
	Hydraulic circuit	9
	Description and operation of lift phases	10
	Fault diagnosis	13
35 110.30	Hydraulic lift - disassembly reassembly	15
35.110.40-42-46	Hydraulic lift - bench overhaul	21
	Adjusting the lift	26
35.110.08	Linkage adjustment	32
35.110.30	Pressure relief valve - disassembly reassembly	34
35.110.32	Pressure relief valve - setting	34
35.110.14	Lift control valve - disassembly assembly and overhaul on bench	36
35.0101.10	Lift pump	41

Open Centre System Auxiliary Control Valves

Chapter 2

Section	Description	Page
35 000	Main data – Tools	1
	Auxiliary control valves – sectional views	2
	Description and operation	3
	Fault diagnosis	see chapter 1
35 204 46	Auxiliary control valves – Assembly-Disassembly	7
	Spool binding test	15
	Spool leakage test	16
	Adjustment of the automatic detent release pressure	17

Trailer Brake Auxiliary Control Valve

Chapter 3

Section	Description	Page
35 000	Section views	1
	Description and operation	1
	Hydraulic diagram	2
	Description and operation of valve phases	3
	Trailer brake auxiliary control valve linkage adjustment	6

STEERING

SECTION 41

Steering

Chapter 1

Section	Description	Page
41 000	Principal data	1
	Tightening torques	3
	Section views	4
	Hydraulic diagram	6
	Operation	7
	Fault diagnosis	9
	Tools	10
41 204 30	Hydrostatic steering control valve – Removal-Installation	11
41 204 34	Hydrostatic steering control valve – Disassembly-Assembly	14
41 204 38	Hydrostatic steering control valve – Bench testing	28
	Hydrostatic steering oil pump – Disassembly-Assembly	30
41 216 20	Steering cylinder (two-wheel drive axle) – Removal-Refitting	32
	Steering cylinder (four wheel drive axle) – Removal-Refitting	33

FRONT AXLE AND WHEELS

SECTION 44

Front Axle And Wheels

Chapter 1

Section	Description	Page
44 000	Principal data	1
	Sectional views	3
	Torque settings	4
	Equipment – Fault diagnosis	5
44 101 30	Removal-Refitting-Overhaul	6
44 101 22	Wheel hub disassembly-assembly	9
44 101 46	Stub axle overhaul	16
44 101 80	Checking wheel alignment	20

AUXILIARY UNITS

SECTION 50

Auxiliary Units

Chapter 1

Section	Description	Page
50 000	Safety instructions	2
	General characteristics	3
	Equipment	4
	Operating principles	5
	Fault diagnosis	7
	Cab controls	11
	Use	14
	Main components of the cab air conditioning system	15
	Refrigerant recovery–recycling and evacuation–charging stations	20
50 200 04	Drying recharging and checking cooling	22
50 200 03	Functional testing of air conditioning system	27
	Summary of the cab air–conditioning system charging operations	28
	Checking for refrigerant leaks using an electronic leak detector	30
	Summary of fault diagnosis and maintenance	31
	Air conditioning and heating pipes – Replacement	33
50 200 04-74	Receiver–drier – Replacement	36
50 200 04-72	Condenser – Replacement	38
50 200 04-26	Compressor – Removal–Refitting	39
50 200 10	Compressor drive belt tension adjustment	41

ELECTRICAL SYSTEM

SECTION 55

Instruments

Chapter 1

Section	Description	Page
	Analogue instruments Introduction	1
	Transmitter and switch	4

Components

Chapter 2

Section	Description	Page
55 500	Introduction	1
	Component description	1

Starting System

Chapter 3

Section	Description	Page
55 000	Technical information	1
	Tightening torques	1
	Description and operation	2
	Starting circuit	3
	System tests	5
55 201	Removal and re-installation of starter motor	8
	Servicing	9
	Bench tests	10

Charging System

Chapter 4

Section	Description	Page
55 000	Technical information	1
	Tightening torques	1
	Description and operation	2
	System testing and trouble-shooting	4
55 301	Removal, re-installation and servicing	10

Battery

Chapter 5

Section	Description	Page
55 000	Technical information	1
	Description and operation	1
55.301.040	Removal and re-installation	2
	Battery checking and maintenance	3
	Charging the battery	4
	Battery problems – Frequent causes	7

Electrical Circuits

Chapter 6

Section	Description	Page
55 100	Contents	1
	Fuses (all versions)	2
	Symbols used in electrical circuits	4
	Electrical wire colour coding	5
	Ground locations	5
	Electrical diagrams	
	- General diagrams (W/Cab)	9
	- General diagrams (W/Out Cab)	15
	- Analogue instrument circuit and connector overview	19
	- Start-up circuit and connector overview	21
	- Direction indicator & hazard warning light circuit and connector overview	25
- Windscreen and rear window wiper/washer circuit and connector overview	31	
- Brake light circuit and connector overview	35	

- Heating and air-conditioning system circuit and connector overview	41
- Work lamp (without cab circuit and connector overview)	45
- Work lamp (without cab circuit and connector overview)	49
- Side lights,main and dipped headlights, parking light circuit and connector overview	53

BODYWORK AND DRIVER POSITION

SECTION 90

Bodywork And Driver Position

Chapter 1

Section	Description	Page
90 160 42 - 43		
90 120 10	Control levers, seat and electrical controls - disassembly and reassembly	2
90 156 52	Rear window, handle and lock - disassembly and reassembly	10
90 154 30	Left-hand door exterior handle and lock - disassembly and reassembly	11
90 154 10	Left-hand door - disassembly and reassembly	12
90 160 60		
55 518 52	Windscreen wiper motor - disassembly and reassembly	13
90154 24		
90 156 10 - 14		
90 156 28	Cab windows - replacement	15

GENERAL INSTRUCTIONS

IMPORTANT NOTICE

All maintenance and repair operations described in this manual should be carried out exclusively by the CASE IH authorised workshops. All instructions detailed should be carefully observed and special equipment indicated should be used if necessary.

Everyone who carries out service operations described without carefully observing these prescriptions will be directly responsible of deriving damages.

SHIMMING

At each adjustment, select adjusting shims, measure them individually using a micrometer and then sum up recorded values. Do not rely on measuring the whole shimming set, which may be incorrect, or on rated value indicated for each shim.

ROTATING SHAFT SEALS

To correctly install rotating shaft seals, observe the following instructions:

- Let the seal soak into the same oil as it will seal for at least half an hour before mounting;
- Thoroughly clean the shaft and ensure that the shaft working surface is not damaged;
- Place the sealing lip towards the fluid. In case of a hydrodynamic lip, consider the shaft rotation direction and orient grooves in order that they deviate the fluid towards the inner side of the seal;
- Coat the sealing lip with a thin layer of lubricant (oil rather than grease) and fill with grease the gap between the sealing lip and the dust lip of double lip seals;
- Insert the seal into its seat and press it down using a flat punch. Do not tap the seal with a hammer or a drift;
- Take care to insert the seal perpendicularly to its seat while you are pressing it. Once the seal is settled, ensure that it contacts the thrust element if required.;
- To prevent damaging the sealing lip against the shaft, place a suitable protection during installation.

O RINGS

Lubricate the O rings before inserting them into their seats. This will prevent the O rings from rolling over and twine during mounting which will jeopardise sealing.

SEALERS

Apply one of the following sealers: RTV SILMATE, RHODORSIL CAF 1, or LOCTITE PLASTIC GASKET over the mating surfaces marked with an X.

Before applying the sealer, prepare the surface as follows:

- remove possible scales using a metal brush;
- thoroughly degrease the surfaces using one of the following cleaning agent: trichlorethylene, petrol or a water and soda solution.

BEARINGS

It is advisable to heat the bearings to 80 to 90°C before mounting them on their shafts and cool them down before inserting them into their seats with external tapping.

ROLL PINS

When fitting straight roll pins, ensure that the pin notch is oriented in the direction of the effort to stress the pin. Coil roll pins can be installed in any position.

NOTES FOR SPARE PARTS

Use exclusively **genuine CASE IH spare parts**, the only ones bearing this logo.

Only genuine parts guarantee same quality, life, safety as original components as they are the same as mounted in production.

Only the **CASE IH genuine spare parts** can offer this guarantee.

All spare parts orders should be complete with the following data:

- tractor model (commercial name) and frame number;
- engine type and number;
- part number of the ordered part, which can be found on the "Microfiches" or the "Spare Parts Catalogue", which is the base for order processing.

NOTES FOR EQUIPMENT

Equipment which CASE IH proposes and shows in this manual are as follows:

- studied and designed expressly for use on CASE IH tractors;
- necessary to make a reliable repair;
- accurately built and strictly tested to offer efficient and long-lasting working means.

We also remind the Repair Personnel that having these equipment means:

- work in optimal technical conditions;
- obtain best results;
- save time and effort;
- work more safely.

NOTICES

Wear limits indicated for some details should be intended as advised, but not binding values. The words "front", "rear", "right hand", and "left hand" referred to the different parts should be intended as seen from the operator's seat oriented to the normal sense of movement of the tractor.

HOW TO MOVE THE TRACTOR WITH THE BATTERY REMOVED

Cables from the external power supply should be connected exclusively to the respective terminals of the tractor positive and negative cables using pliers in good condition which allow proper and steady contact.

Disconnect all services (lights, wind-shield wipers, etc.) before starting the tractor.

If it is necessary to check the tractor electrical system, check it only with the power supply connected. At check end, disconnect all services and switch the power supply off before disconnecting the cables.

SAFETY RULES

PAY ATTENTION TO THIS SYMBOL



This warning symbol points out important messages involving personal safety. Carefully read the safety rules contained herein and follow advised precautions to avoid potential hazards and safeguard your safety and personal integrity.

In this manual you will find this symbol together with the following key-words:

WARNING - it gives warning about improper repair operations and deriving potential consequences affecting the service technician's personal safety.

DANGER - it gives specific warning about potential dangers for personal safety of the operator or other persons directly or indirectly involved.



TO PREVENT ACCIDENTS

Most accidents and personal injuries taking place in workshops are due from non-observance of some simple and essential prudential rule and safety precautions. For this reason, **IN MOST CASES THEY CAN BE AVOIDED**. It suffices to foresee possible causes and act consequently with necessary caution and care.

The possibility that an accident might occur with any type of machines should not be disregarded, no matter how well the machine in question was designed and built.

A wise and careful service technician is the best precautions against accidents.

Careful observance of this only basic precaution would be enough to avoid many severe accidents.

DANGER: Never carry out any cleaning, lubrication or maintenance operations when the engine is running.

SAFETY RULES

GENERALITIES

- ◇ Carefully follow specified repair and maintenance procedures.
- ◇ Do not wear rings, wristwatches, jewels, unbuttoned or flapping clothing such as ties, torn clothes, scarves, open jackets or shirts with open zips which could get hold into moving parts. We advise to use approved safety clothing such as anti-slipping footwear, gloves, safety goggles, helmets, etc.
- ◇ Never carry out any repair on the machine if someone is sitting on the operator's seat, except if they are certified operators to assist in the operation to be carried out.
- ◇ Never operate the machine or use attachments from a place other than sitting at the operator's seat.
- ◇ Never carry out any operation on the machine when the engine is running, except when specifically indicated.
- ◇ Stop the engine and ensure that all pressure is relieved from hydraulic circuits before removing caps, covers, valves, etc.
- ◇ All repair and maintenance operations should be carried out with the greatest care and attention.
- ◇ Service stairs and platforms used in a workshop or in the field should be built in compliance with the safety rules in force.
- ◇ Disconnect the batteries and label all controls to warn that the tractor is being serviced. Block the machine and all equipment which should be raised.
- ◇ Never check or fill fuel tanks and accumulator batteries, nor use starting liquid if you are smoking or near open flames as such fluids are flammable.
- ◇ Brakes are inoperative when they are manually released for maintenance purposes. In such cases, the machine should be kept constantly under control using blocks or similar devices.
- ◇ The fuel filling gun should remain always in contact with the filler neck. Maintain this contact until the fuel stops flowing into the tank to avoid possible sparks due to static electricity buildup.

- ◇ Use exclusively specified towing points for towing the tractor. Connect parts carefully. Ensure that foreseen pins and/or locks are steadily fixed before applying traction. Do not stop near towing bars, cables or chains working under load.
- ◇ To transfer a failed tractor, use a trailer or a low loading platform trolley if available.
- ◇ To load and unload the machine from the transportation mean, select a flat area providing a firm support to the trailer or truck wheels. Firmly tie the machine to the truck or trailer platform and block wheels as required by the forwarder.
- ◇ For electrical heaters, battery-chargers and similar equipment use exclusive auxiliary power supplies with a efficient ground to avoid electrical shock hazard.
- ◇ Always use lifting equipment and similar of appropriate capacity to lift or move heavy components.
- ◇ Pay special attention to bystanders.
- ◇ Never pour gasoline or diesel oil into open, wide and low containers.
- ◇ Never use gasoline, diesel oil or other flammable liquids as cleaning agents. Use non-flammable non-toxic proprietary solvents.
- ◇ Wear protection goggles with side guards when cleaning parts using compressed air.
- ◇ Do not exceed a pressure of 2.1 bar, in accordance with local regulations.
- ◇ Do not run the engine in a closed building without proper ventilation.
- ◇ Do not smoke, use open flames, cause sparks in the nearby area when filling fuel or handling highly flammable liquids.
- ◇ Do not use flames as light sources when working on a machine or checking for leaks.
- ◇ Move with caution when working under a tractor, and also on or near a tractor. Wear proper safety accessories: helmets, goggles and special footwear.
- ◇ During checks which should be carried out with the engine running, ask an assistant to seat at the operator's seat and keep the service technician under visual control at any moment.
- ◇ In case of operations outside the workshop, drive the tractor to a flat area and block it. If working on an incline cannot be avoided, first block the tractor carefully. Move it to a flat area as soon as possible with a certain extent of safety.
- ◇ Ruined or plied cables and chains are unreliable. Do not use them for lifting or trailing. Always handle them wearing gloves of proper thickness.
- ◇ Chains should always be safely fastened. Ensure that fastening device is strong enough to hold the load foreseen. No persons should stop near the fastening point, trailing chains or cables.
- ◇ The working area should be always kept CLEAN and DRY. Immediately clean any spillage of water or oil.
- ◇ Do not pile up grease or oil soaked rags, as they constitute a great fire hazard. Always place them into a metal container.
Before starting the tractor or its attachments, check, adjust and block the operator's seat. Also ensure that there are no persons within the tractor or attachment operating range.
- ◇ Do not keep into your pockets any object which might fall unobserved into the tractor's inner compartments.
- ◇ Whenever there is the possibility of being reached by ejected metal parts or similar, use protection eye mask or goggles with side guards, helmets, special footwear and heavy gloves.
- ◇ Wear suitable protection such as tinted eye protection, helmets, special clothing, gloves and footwear whenever it is necessary to carry out welding procedures. All persons standing in the vicinity of the welding process should wear tinted eye protection. NEVER LOOK AT THE WELDING ARC IF YOUR EYES ARE NOT SUITABLY PROTECTED.
- ◇ Metal cables with the use get frayed. Always wear adequate protections (heavy gloves, eye protection, etc.)
- ◇ Handle all parts with the greatest caution. Keep your hands and fingers far from gaps, moving gears and similar. Always use approved protective equipment, such as eye protection, heavy gloves and protective footwear.

START UP

- ◇ Never run the engine in confined spaces which are not equipped with adequate ventilation for exhaust gas extraction.
- ◇ Never bring your head, body, arms, legs, feet, hands, fingers near fans or rotating belts.

ENGINE

- ◇ Always loosen the radiator cap very slowly before removing it to allow pressure in the system to dissipate. Coolant should be topped up only when the engine is stopped or idle if hot.
- ◇ Do not fill up fuel tank when the engine is running, mainly if it is hot, to avoid ignition of fires in case of fuel spilling.
- ◇ Never check or adjust the fan belt tension when the engine is running.
Never adjust the fuel injection pump when the tractor is moving.
- ◇ Never lubricate the tractor when the engine is running.

ELECTRICAL SYSTEMS

- ◇ If it is necessary to use auxiliary batteries, cables must be connected at both sides as follows: (+) to (+) and (-) to (-). Avoid short-circuiting the terminals. **GAS RELEASED FROM BATTERIES IS HIGHLY FLAMMABLE.** During charging, leave the battery compartment uncovered to improve ventilation. Avoid checking the battery charge by means of "jumpers" made by placing metallic objects across the terminals. Avoid sparks or flames near the battery area. Do not smoke to prevent explosion hazards.
- ◇ Prior to any service, check for fuel or current leaks. Remove these leaks before going on with the work.
- ◇ Do not charge batteries in confined spaces. Ensure that ventilation is appropriate to prevent accidental explosion hazard due to build-up of gases released during charging.
- ◇ Always disconnect the batteries before performing any type of service on the electrical system.

HYDRAULIC SYSTEMS

- ◇ Some fluid slowly coming out from a very small port can be almost invisible and be strong enough to penetrate the skin. For this reason, **NEVER USE YOUR HANDS TO CHECK FOR LEAKS**, but use a piece of cardboard or a piece of wood to this purpose. If any fluid is injected into the skin, seek medical aid immediately. Lack of immediate medical attention, serious infections or dermatosis may result.
- ◇ Always take system pressure readings using the appropriate gauges.

WHEELS AND TYRES

- ◇ Check that the tyres are correctly inflated at the pressure specified by the manufacturer. Periodically check possible damages to the rims and tyres.
- ◇ Keep off and stay at the tyre side when correcting the inflation pressure.
- ◇ Check the pressure only when the tractor is unloaded and tyres are cold to avoid wrong readings due to over-pressure. Do not reuse parts of recovered wheels as improper welding, brazing or heating may weaken the wheel and make it fail.
- ◇ Never cut, nor weld a rim with the inflated tyre assembled.
- ◇ To remove the wheels, block both front and rear tractor wheels. Raise the tractor and install safe and stable supports under the tractor in accordance with regulations in force.
- ◇ Deflate the tyre before removing any object caught into the tyre tread.
- ◇ Never inflate tyres using flammable gases as they may originate explosions and cause injuries to bystanders.

REMOVAL AND INSTALLATION

- ◇ Lift and handle all heavy components using lifting equipment of adequate capacity. Ensure that parts are supported by appropriate slings and hooks. Use lifting eyes provided to this purpose. Take care of the persons near the loads to be lifted.
- ◇ Handle all parts with great care. Do not place your hands or fingers between two parts. Wear approved protective clothing such as safety goggles, gloves and footwear.
- ◇ Do not twine chains or metal cables. Always wear protection gloves to handle cables or chains.

CONSUMABLES

COMPONENT TO BE FILLED OR TOPPED UP	QUANTITY			CASE IH RECOMMENDED PRODUCTS	INTERNATIONAL SPECIFICATION
	litres/dm ³	US gal	IMP gal		
Cooling system: JX60, JX70 models JX80, JX90, JX95 models with cab : JX60, JX70 models JX80, JX90, JX95 models	12 14 14 16	3.2 3.7 3.7 4.2	2.64 3.08 3.1 3.5	Water & liquid AKCELA PREMIUM ANTI-FREEZE 50% + 50%	-
Windscreen washer bottle	2	0.53	0.44	Water & cleaning liquid	-
Fuel tank	92	24.3	20.2	Decanted and filtered diesel fuel	-
Engine sump: without filter : JX60, JX70 models JX80, JX90, JX95 models with filter : JX60, JX70 models JX80, JX90, JX95 models	7.6 10.5 8.3 11.2	1.98 2.77 2.19 2.96	1.67 2.31 1.83 2.46	AKCELA No.1 ENGINE OIL API CH-4 * ACEA E5 * MB 228.3 * CUMMINS CES 200072/20076/20077	API CF-4/SG CCMC D4 MIL-L-2104E
Brake control circuit	0.4	0.1	0.09	AKCELA LHM FLUID Oil	ISO 7308
Hydrostatic steering circuit	2.0	0.5	0.44	Oil AKCELA NEXPLORE	API GL4 ISO 32/46 SAE 10W-30
Front axle: - axle housing : JX60, JX70 models JX80, JX90, JX95 models - final drives (each) : JX60, JX70 HP models JX80, JX90, JX95 models	4.5 7.0 0.8 1.25	1.2 1.8 0.2 0.3	0.99 1.54 0.18 0.28		
Rear transmission (bevel drive and brakes), gearbox, hydraulic lift and PTO JX60, JX70, JX80, JX90, JX95 models	46	12.15	10.12		
- with synchro-reverser: JX60, JX70, JX80, JX90, JX95 models	46	12.15	10.12		
Rear final drives (each) : JX60, JX70 HP models JX80, JX90, JX95 models	3.9 5.3	1.03 1.40	0.86 1.17		
Front wheel hubs	-	-	-	Grease AKCELA MULTI-PURPOSE GREASE (251H EP)	NLGI 2
Grease fittings	-	-	-		

SECTION 10 - ENGINE

Chapter 1 - Engine

CONTENTS

Section	Description	Page
10 000	General specification	2
	Injection pump calibration data	5
	General specifications	16
	Tightening torques	24
	Tools	25
	Cross-sectional views	28
	Lubrication and cooling system diagrams	32
	Fault diagnosis	35
10 001 10	Engine <i>Removal-Installation</i>	39
10 001 54	Engine <i>Bench overhaul</i>	53
	Checks, measurements and repairs	78
10 406 10	Radiator <i>Removal-Installation</i>	102
10 102 70	Crankshaft front oil seal <i>removal installation</i>	106
10 402 10	Coolant pump <i>removal installation</i>	112
10 402 30	Cooling system thermostat	115
10 206 14	Bosch injection pump <i>removal installation</i>	118
	Bosch injection pump <i>timing</i>	121
	Bosch injection pump <i>air bleeding</i>	123
10 218 30	Injectors <i>removal installation</i>	124
10 106 12	Valve clearance adjustment	126
10 402 28	Coolant pump overhaul	129
10 001 30	Compression test	130

GENERAL SPECIFICATIONS	3 cylinders	4 cylinders
Engine type:		
- mod. JX60 normally aspirated - type 8035.05D.939 (BOSCH pump)	see data pages 6-7	-
- mod. JX70 turbocharged - type 8035.25C.939 (BOSCH pump)	see data pages 8-9	-
- mod. JX80 normally aspirated - type 8045.05R.939 (BOSCH pump)	-	see data pages 10-11
- mod. JX90 turbocharged - type 8045.25.939 (BOSCH pump)	-	see data pages 12-13
- mod. JX95 turbocharged - type 8045.25L.939 (BOSCH pump)	-	see data pages 14-15
Cycle	Diesel, 4-stroke	
Fuel injection	Direct	
Number of cylinders in line	3	4
Cylinder liners		dry force-fitted in cylinder block
Piston diameter		
- mod. JX60	104 mm (4.0945 in.)	-
- mod. JX70	104 mm (4.0945 in.)	-
- mod. JX80	-	104 mm (4.0945 in.)
- mod. JX90	-	104 mm (4.0945 in.)
- mod. JX95	-	104 mm (4.0945 in.)
Piston stroke	115 mm (4.5276 in.)	
Total displacement:		
- mod. JX60-JX70	2931 cm ³ (178.8496 in. ³)	-
- mod. JX80-JX90-JX95	-	3908 cm ³ (238.4662 in. ³)
Compression ratio	17 to 1 normally aspirated 16.5 to 1 turbocharged	
Maximum power 2000/25 EC at 2500 rpm:		
- mod. JX60	43.4 kW (59 hp)	-
- mod. JX70	50.7 kW (69 hp)	-
- mod. JX80	-	58.8 kW (80 hp)
- mod. JX90	-	65.5 kW (89 hp)
- mod. JX95	-	69.1 kW (94 hp)
Maximum power ECE R 24 at 2500 rpm:		
- mod. JX60	41.2 kW (56 hp)	-
- mod. JX70	47.8 kW (65 hp)	-
- mod. JX80	-	55.9 kW (76 hp)
- mod. JX90	-	63.3 kW (86 hp)
- mod. JX95	-	66.9 kW (91 hp)
Fast idling speed	2500 rpm.	
Maximum torque (daNm) at 1500 rpm: JX60 model	20.7 (152.6753 ft lb)	-
Maximum torque (daNm) at 1500 rpm: JX70 model	25.0 (184.3905 ft lb)	-
Maximum torque (daNm) at 1500 rpm: JX80 model	-	27.9 (205.9778 ft lb)
Maximum torque (daNm) at 1500 rpm: JX90 model	-	32.0 (236.0194 ft lb)
Maximum torque (daNm) at 1500 rpm: JX95 model	-	33.7 (248.5584 ft lb)
Number of main bearings	4	5
Sump	Structural, cast iron	

(continued)

GENERAL SPECIFICATIONS	3 cylinders	4 cylinders
Lubrication Pump drive Engine speed/oil pump speed ratio Oil cleaning Normal oil pressure, with engine hot and at fast idling speed . Pressure relief valve Valve opening pressure For further lubrication data	forced, with gear pump camshaft 2:1 mesh filter on oil intake and cartridge filter on delivery line 2.9 to 3.9 bar (42.06 to 56.56 psi) built into pump housing 3.5 bar (50.76 psi) See page 23	
Cooling system Radiator on JX60, JX70, JX80 and JX90 models Radiator on JX95 models Fan, attached to coolant pump pulley Coolant pump Engine speed/coolant pump speed ratio Temperature control Coolant temperature gauge Temperature ranges corresponding to each section: - initial white section - middle green section - final red section For further cooling system data	coolant circulation three-row vertical pipes with copper fins four-row vertical pipes with copper fins four-blade steel exhauster fan 6-blade steel exhauster fan (JX95) centrifugal vane-type 1:1,403 Thermostat coloured scale divided into three sections from 30° to 65° C (86° to 149° F) from 65° to 105° C (149° to 221° F) from 105° to 115° C (221° to 300.2° F) See page 23	
Rev counter Rev counter drive Hour counter calibrated for engine speed of	incorporated in control panel from gear on camshaft 1800 rpm.	

(Continued)

(continued)

GENERAL SPECIFICATIONS	3 cylinders	4 cylinders
Timing Intake: - start: before T.D.C - end: after B.D.C Exhaust: - start: before B.D.C - end: after T.D.C Valve clearance for timing check Valve clearance for normal running (engine cold): - intake - exhaust For further timing data	overhead valves operated by a camshaft located in the engine block through tappets, pushrods and rockers. Camshaft is driven by the crankshaft through helical gears. 12° 31° 50° 16° 0.45 mm (0.0177 in.) 0.30 ± 0.05 mm (0.0118 ± 0.0020 in.) 0.30 ± 0.05 mm (0.0118 ± 0.0020 in.) See page 20	
Fuel System Air cleaning Fuel pump Fuel filter Minimum fuel flow rate with pump shaft rotating at 1600 rev/min. Operated by eccentric cam BOSCH Injection pump All-speed governor, incorporated in pump: BOSCH Automatic advance regulator, incorporated in pump: BOSCH For further fuel system data: For fixed advance (pump setting for start of delivery before TDC) - Pressure setting - Injection order, and other information regarding the BOSCH pump	dual cartridge dry air filter, with clogged filter indicator with centrifugal pre-filter and automatic dust ejector. with double diaphragm mesh filter in fuel supply pump, and replaceable cartridge on delivery line to injection pump. 100 litres/hour on camshaft rotary distributor type centrifugal counterweights hydraulic see pages 5 to 15 refer to the data for the relevant engine type in the tables from page 6 to page 14.	

DATA

Turbocharger (Model JX95): - GARRETT type		T25			
Fuel injection pump BOSCH pump: - JX60 model - JX70 model - JX80 model - JX90 model - JX95 model Direction of rotation Injection order		distributor type with incorporated speed governor and automatic advance regulator VE 3/12 F 1250 L 976 - 504054473 VE 3/12 F 1250 L 977 - 504054474 VE 4/12 F 1250 L 985 - 504041416 VE 4/12 F 1250 L 982 - 504042214 VE 4/12 F 1250 L 952 - 504042718 anticlockwise 1-2-3 (JX60 and JX70) 1-3-4-2 (JX80, JX90 and JX95)			
Fuel injectors: BOSCH - Nozzle holder type - Nozzle type Number of nozzle holes Diameter of nozzle orifices Pressure setting	5 248-272 bar (3596.9176-3945.0064 psi)	6 248-272 bar (3596.9176-3945.0064 psi)			
	JX70	JX95	JX60	JX80	JX90
Fuel delivery lines - BOSCH pump - Type - Dimensions mm	-	-	-	-	-

ENGINE**Removal - Installation (Operation 10 001 10)****DANGER**

Lift and handle all heavy parts using suitable lifting equipment.

Make sure that assemblies or parts are supported by means of suitable slings and hooks.

Check that no one is in the vicinity of the load to be lifted.

**WARNING**

Always use suitable tools to align holes in parts.
NEVER USE FINGERS OR HANDS.

1. Disconnect the battery negative cable.
2. Drain oil from the transmission/gearbox.
3. Drain the cooling system.

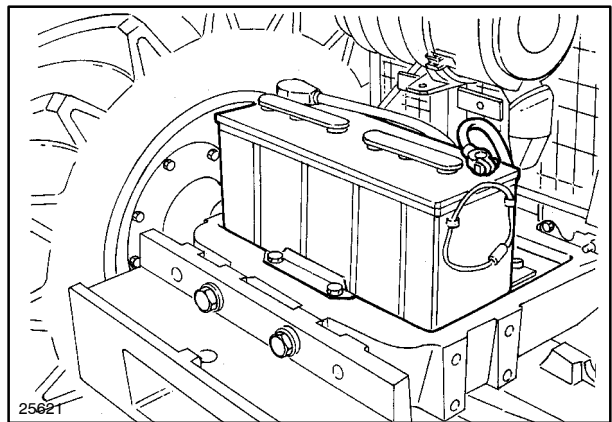

10

4. Unscrew the nut (1) from the weight retaining pin.

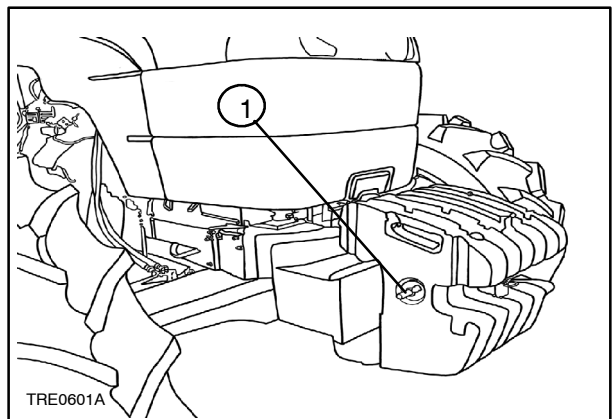

11

5. Remove the weights (1) from the front support.

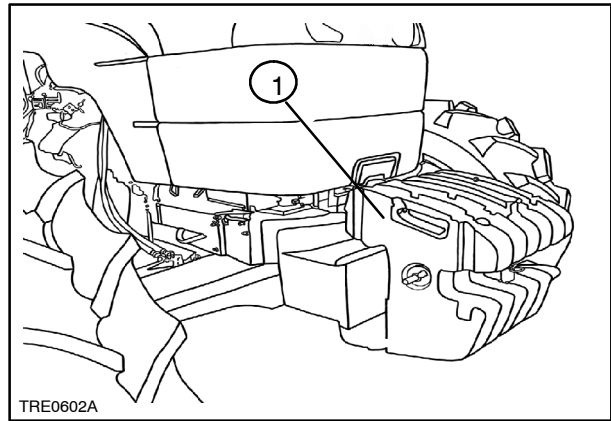

12

6. Remove the exhaust pipe, attach lifting chains to the bonnet (1) and attach the chain to the hoist.

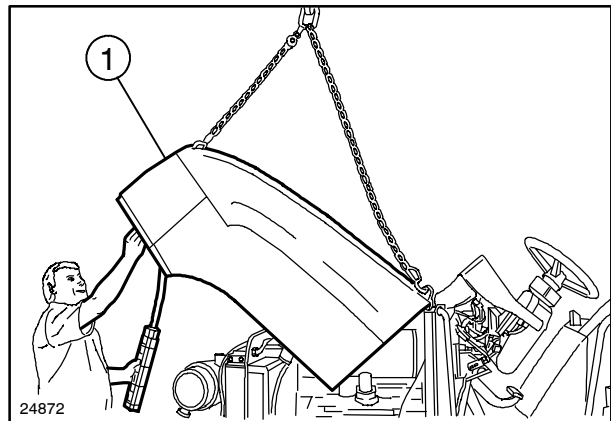

13

7. Disconnect the electrical leads (1) from headlamps (2).

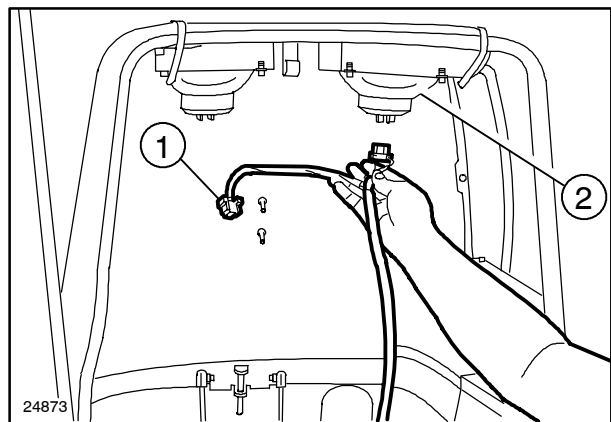

14

8. Detach the gas struts (1) from the bonnet.

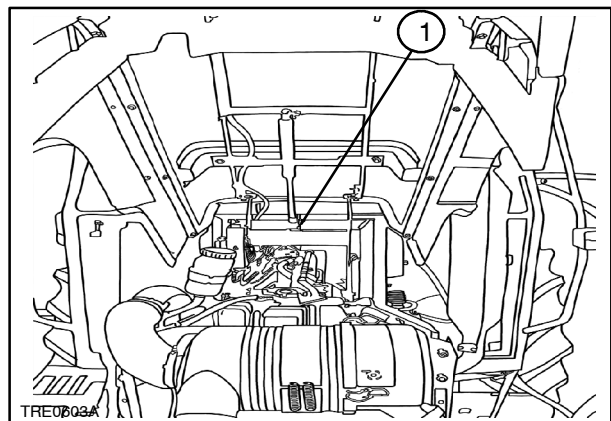

15

9. Remove the four bonnet hinge bolts (1) and lift the bonnet clear.

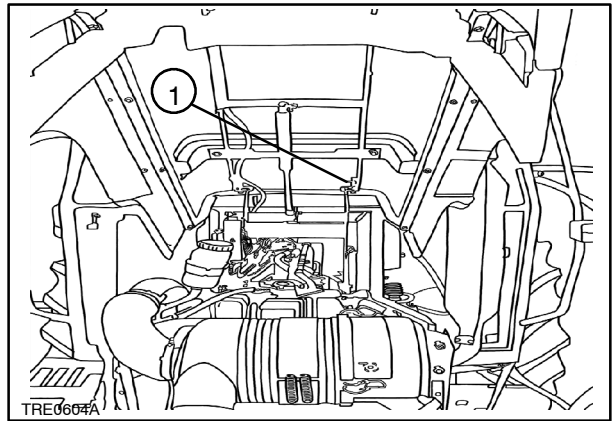

16

10. Remove the wire mesh guard (1) from right-hand side of the fan.

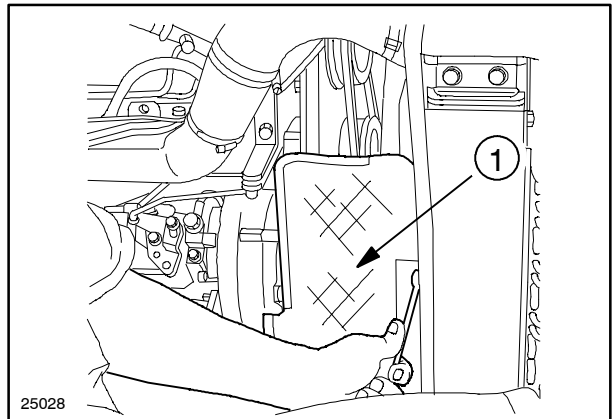

17

11. Disconnect the tachometer cable (1) and remove the retaining ring and sleeve.

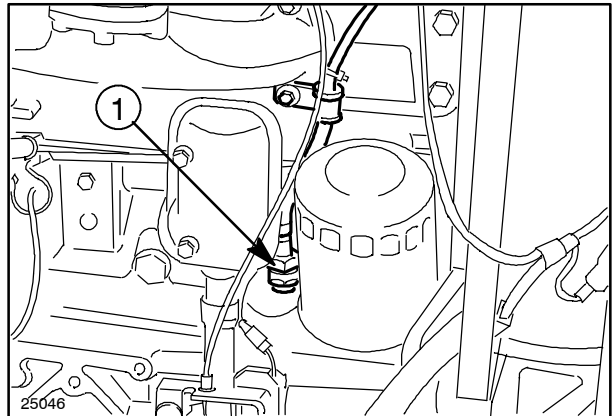

18

12. Detach the throttle control spring (1) and remove the throttle lever (2).

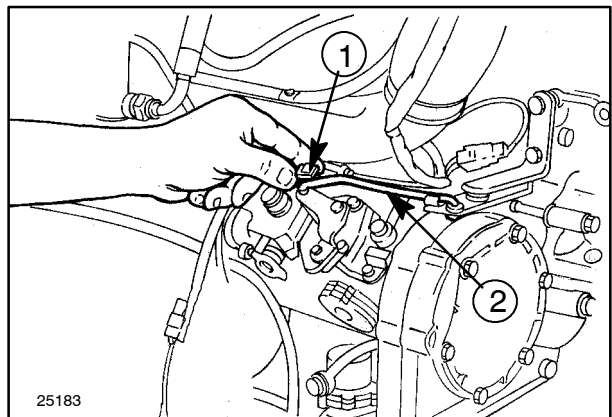

19

13. After recovering the air-conditioner gas (HRC 134a) with the **recovery and recycling station 294048**, disconnect the pipes of the cab air conditioner (1) and (2).

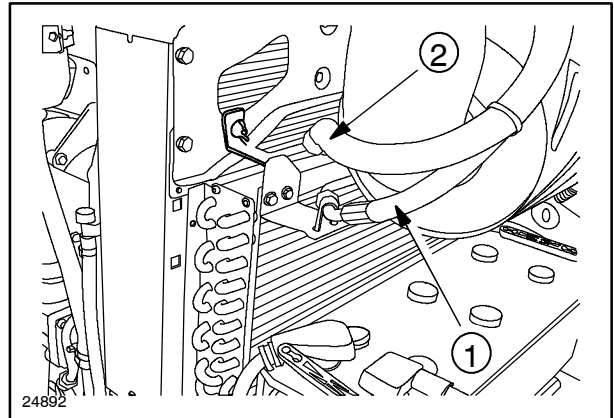

20

14. Detach the cab heating pipes (1) and (2).

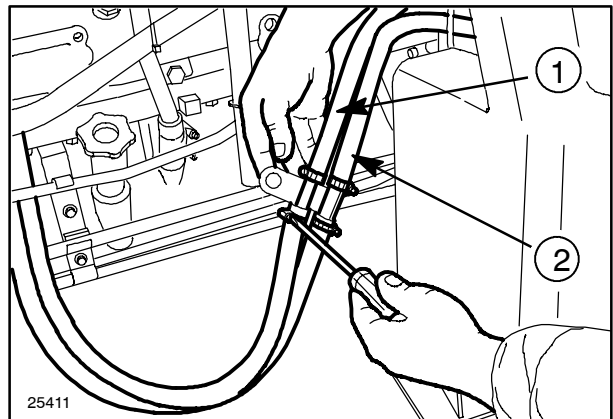

21

15. Disconnect the power steering hoses (1).

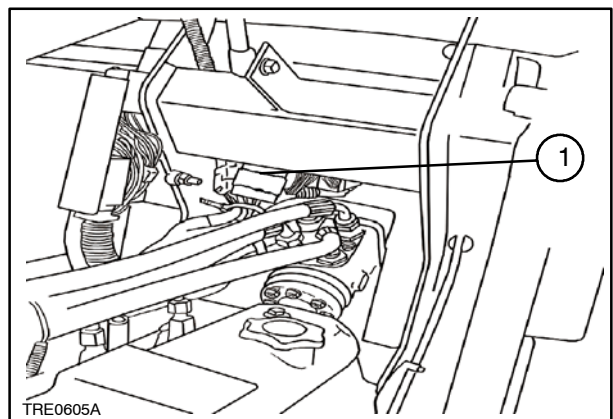

22

16. Disconnect the electrical connectors. Detach the fusebox by unscrewing the nut (1).

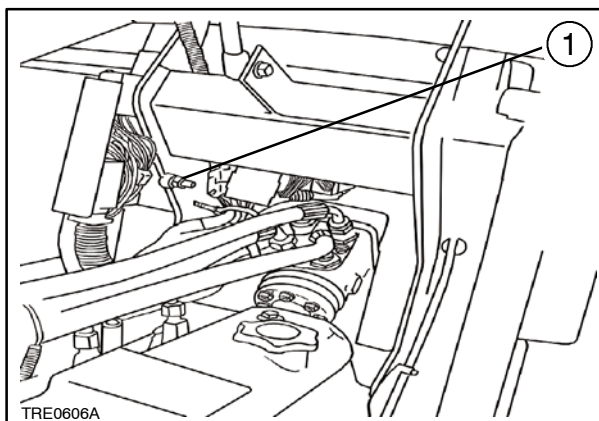

23

17. Disconnect the delivery and return lines (1) to the power steering cylinders.

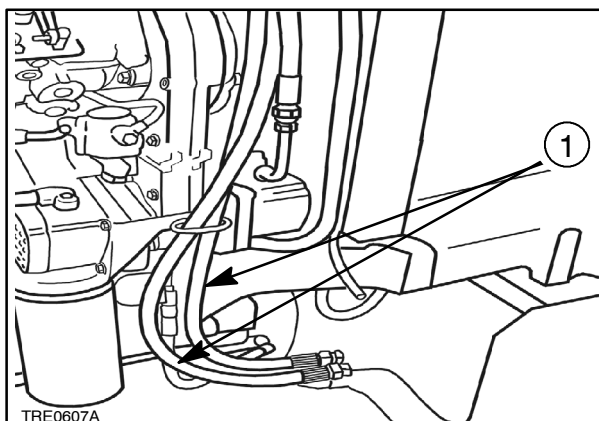

24

18. Remove the hose (1) from the lift pump suction pipe.

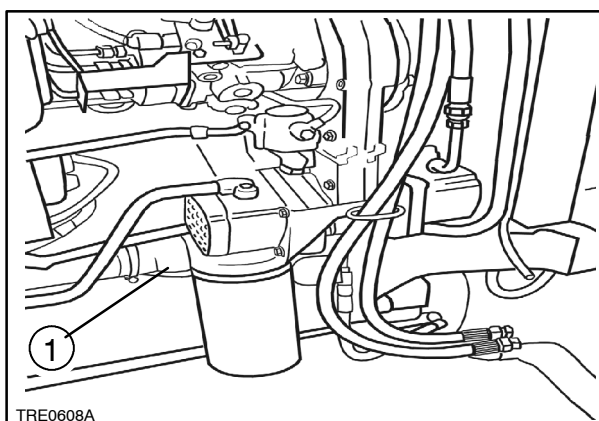

25

19. Detach the lift pump delivery pipe (1).

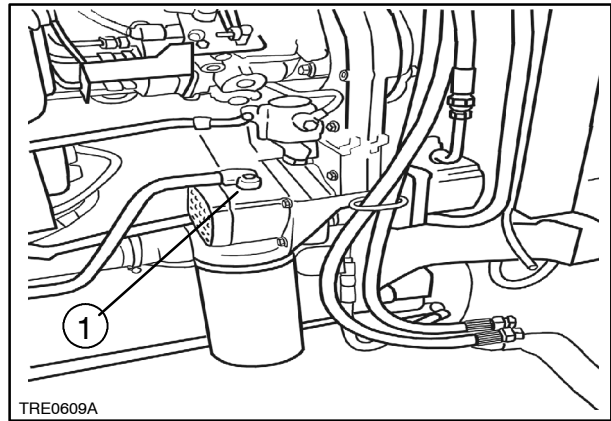

26

20. Detach the fuel pipes from the injection pump and fuel pump and the pipe connecting the tank to the sedimentation filter.

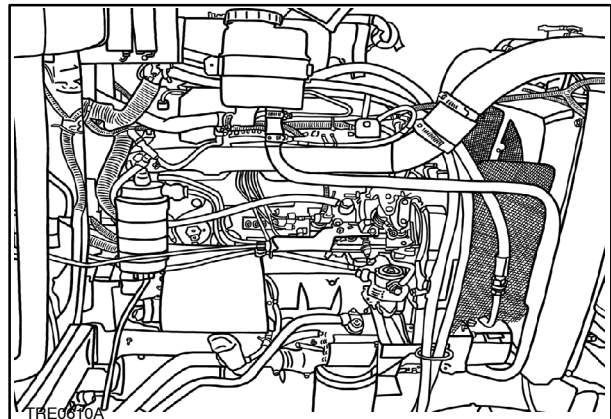

27

21. Remove the fuel filter (1) complete with its support.

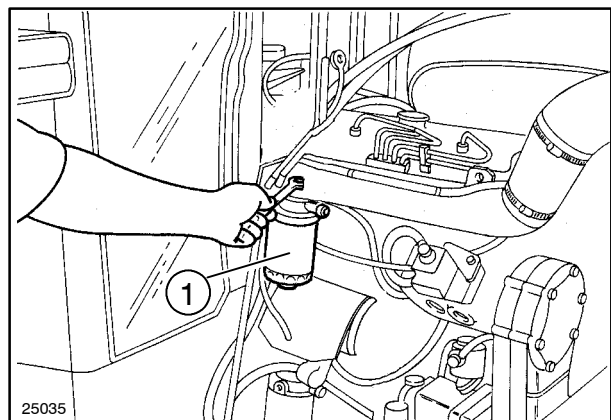

28

22. Remove the front, centre and rear retaining bolts from the front axle drive shaft guard and remove the guard.

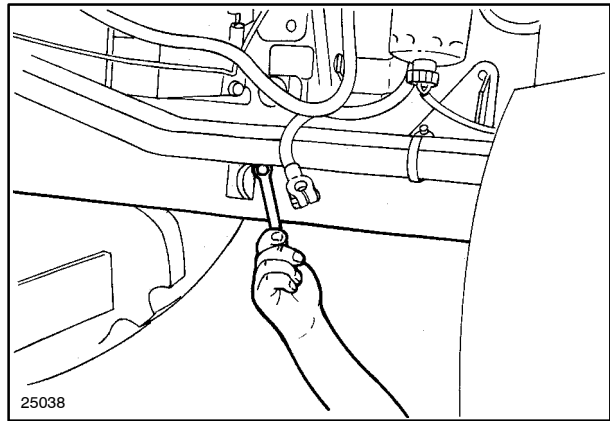

29

23. Remove the circlip (2) from the front of the prop shaft and slide the sleeve (1), in the direction shown by the arrow, until it is free of the splines on the front axle.

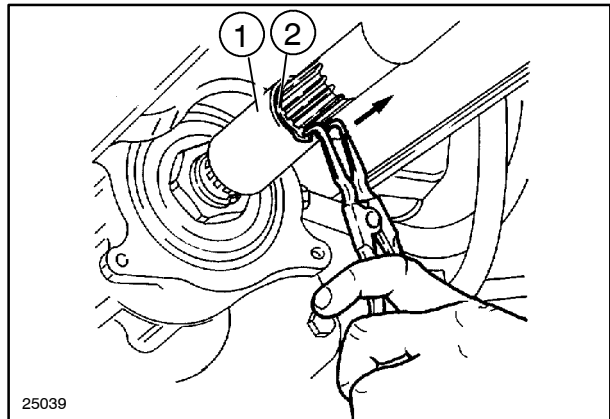

30

24. Remove the circlip (2) from the rear of the prop shaft and slide the sleeve (1), in the direction shown by the arrow, until it is free of the splines on the crankshaft.

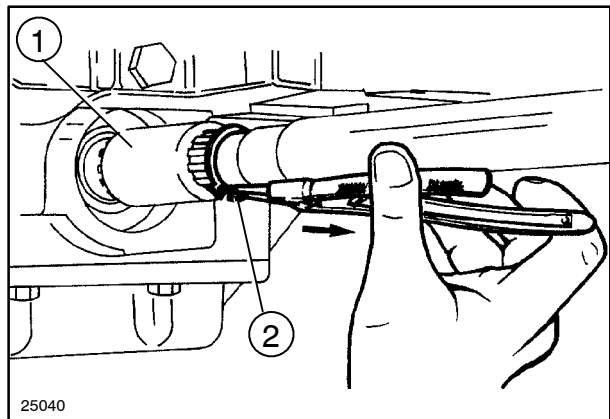

31

25. Remove the middle support bolts (1) from the propeller shaft and remove the shaft complete with support.

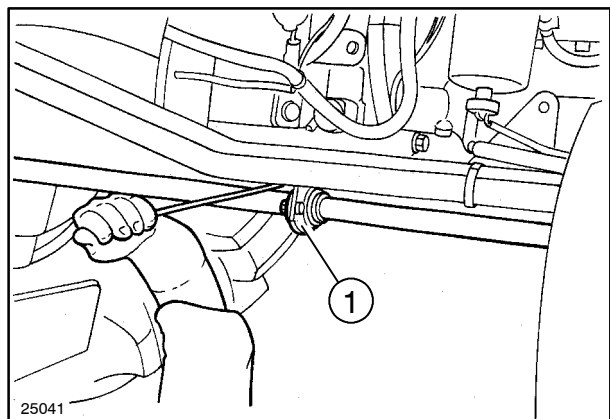

32

26. Withdraw the pin securing the differential lock (1) knob, remove the knob and remove the mat (2) from the floor.

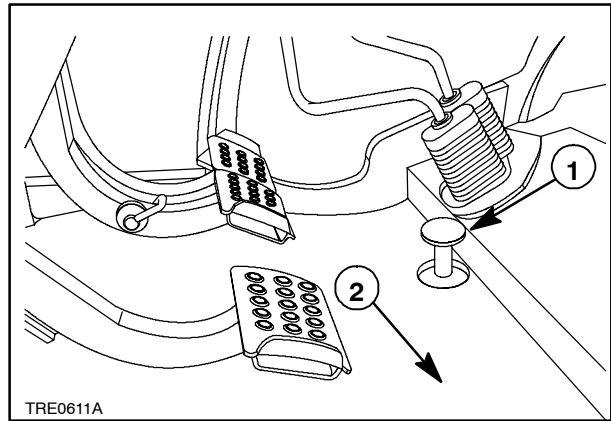

33

27. Unscrew the nuts (1) and the bolts securing the engine to the transmission. Access is through the two slots in the cab floor.

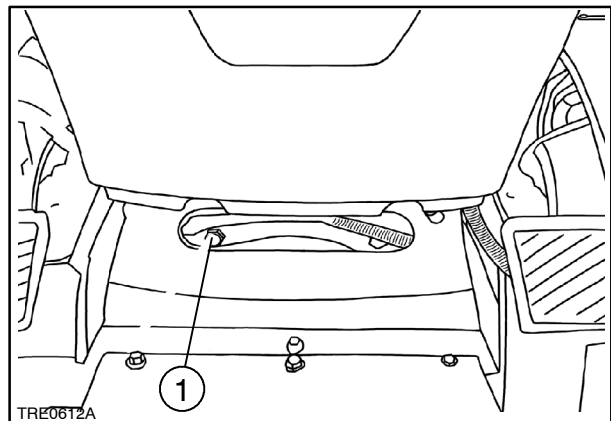

34

28. Unscrew the four lower bolts (1) securing the engine to the transmission.

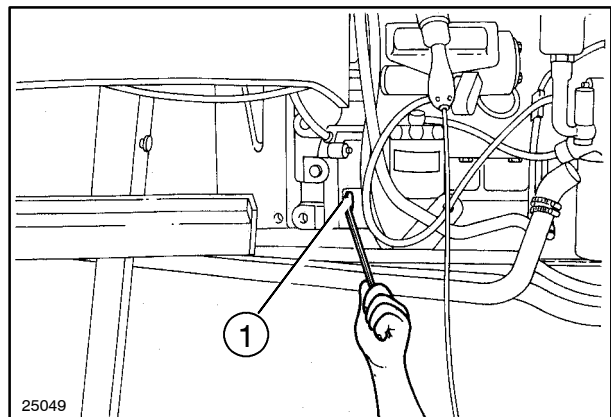

35



Suggest:

For more complete manuals. Please go to the home page.

<https://www.ebooklibonline.com>

If the above button click is invalid. Please download this document first, and then click the above link to download the complete manual.

Thank you so much for reading

29. Position stand **380000236** underneath the tractor and insert a wedge (1), either side of the axle, to prevent the axle from pivoting.

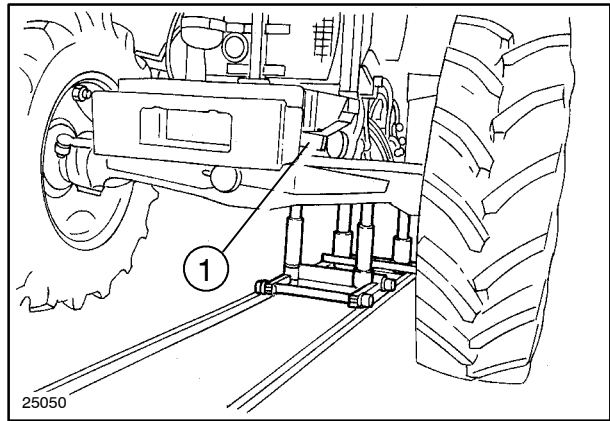

36

30. Insert a wooden block between the stands and the tractor.

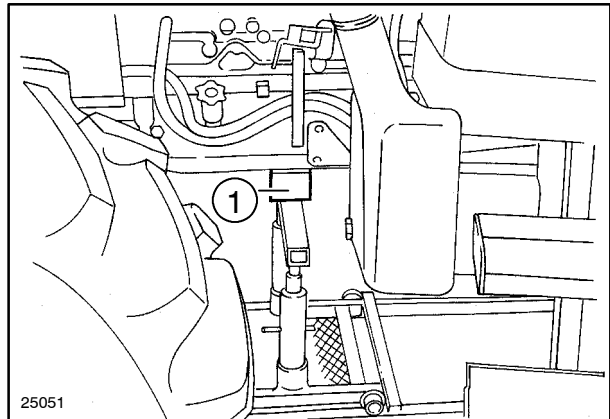

37

31. Place a fixed stand (1) underneath the drawbar support and apply the handbrake.

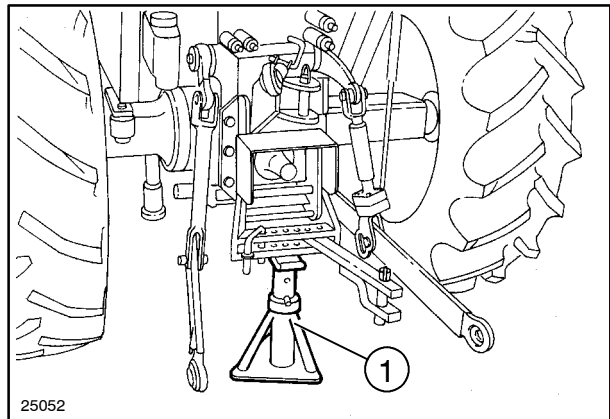

38

32. Unscrew the four remaining bolts securing the engine to the transmission.
 33. Separate the engine from the transmission.
 34. Remove the spacer collar (1) between the engine and the transmission on the JX95 model.

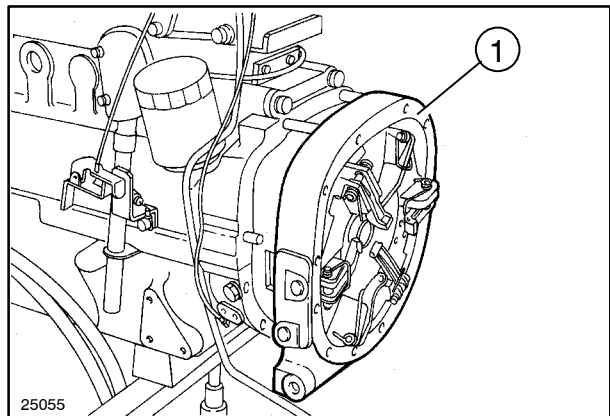

39

35. Place a fixed stand (1) underneath the front weight support and chock the wheels with wooden wedges (2).

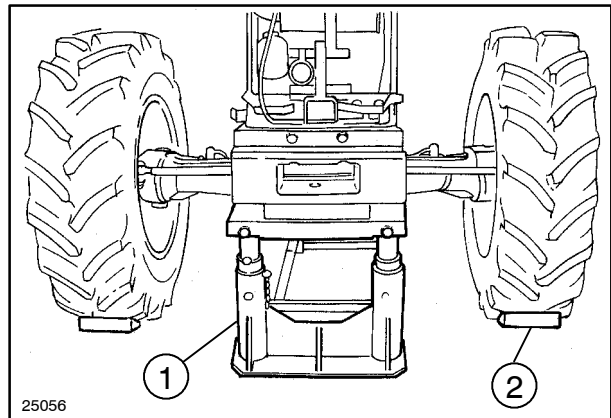

40

36. Insert the pin of kit **380000612** (11"/11" clutch) or the pin **380000292** (12"/12" clutch) (1) into the central hole of the clutch. Unscrew the six bolts (2) securing the clutch to the flywheel and remove complete clutch assembly.

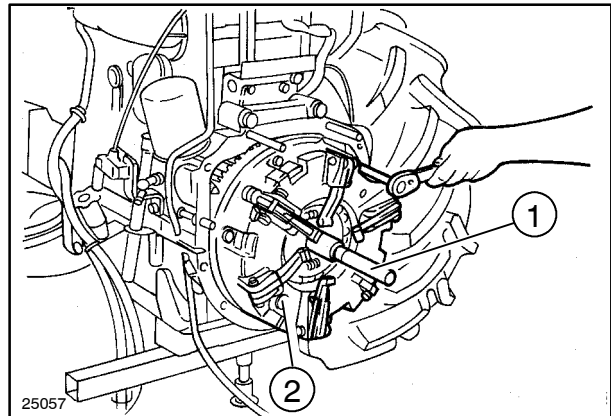

41

37. Remove the radiator mounting bolt (1).

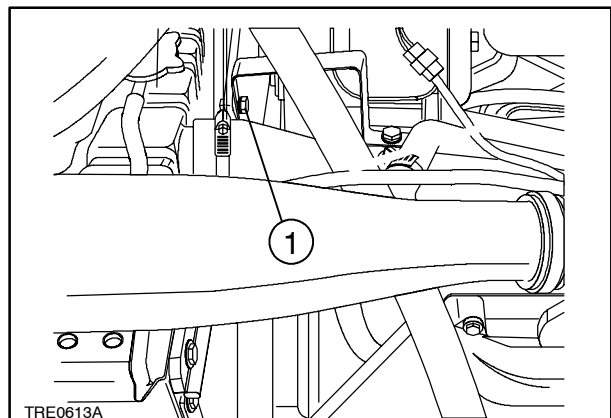

42

<https://www.ebooklibonline.com>

Hello dear friend!

Thank you very much for reading.

Enter the link into your browser.

The full manual is available for immediate download.

<https://www.ebooklibonline.com>