

# DC162 Disc Mower-Conditioner

## Service Manual

84207372 3/09  
1st Printing



# **DC162 SERVICE MANUAL CONTENTS**

**SECTION 00 - GENERAL INFORMATION**

**SECTION 31 - IMPLEMENT POWER TAKE-OFF  
(PTO)**

**SECTION 35 - HYDRAULIC SYSTEM**

**SECTION 39 - FRAMES/TONGUE AND HITCHES**

**SECTION 55 - ELECTRICAL SYSTEM**

**SECTION 58 - ATTACHMENTS/HEADERS**

**SECTION 90 - DECALS**

**The sections used through out all Case IH product Service manuals may not be used for each product. Each Service manual will be made up of one or several books. Each book will be labeled as to which sections are in the overall Service manual and which sections are in each book.**

**The sections listed above are the sections utilized for the DC162.**

**SECTION 00 - GENERAL INFORMATION**

**Chapter 1 - General Information**

**CONTENTS**

<b>Section</b>	<b>Description</b>	<b>Page</b>
	Special Tools .....	2
	Specifications .....	2
	Model DC162 .....	2
	Recommended Lubricants and Coolants .....	6
	Minimum Hardware Tightening Torques .....	7
	Installation of Adjustable Fittings In Straight Thread O-ring Bosses .....	9
	Standard Torque Data for Hydraulic Tubes and Fittings .....	9
	Pipe Thread Fitting Torque .....	10
	Installation of ORFS (O-ring Flat Faced) Fittings .....	10

**<https://www.ebooklibonline.com>**

Hello dear friend!

Thank you very much for reading.

Enter the link into your browser.

The full manual is available for immediate download.

**<https://www.ebooklibonline.com>**

**SPECIAL TOOLS**

Tool Number	Description/Use
<b>Section 31</b>	
NHO1386	Pivot tongue gearbox neck cap screws
610R	Snap ring remover
Local Manufacture	Neck lock nut removal
Local Manufacture	Holding tool for neck housing
Local Manufacture	Neck rolling torque measurement
<b>Section 58</b>	
FNH23ET95	Top cap bearing cover
FNH01221-2	Cutter bar tie bolt holding tool
FNH01221-3	Cutter bar wrench

**SPECIFICATIONS**

**MODEL DC162**

	<b>Standard Tongue</b>	<b>Swivel Hitch Tongue</b>
Overall Width		
Transport position . . . . .	4801 mm (15 ft 9 in)	4801 mm (15 ft 9 in)
Field position . . . . .	7087 mm (23 ft 3 in)	7595 mm (24 ft 11 in)
Overall Length		
Transport position . . . . .	8966 mm (29 ft 5 in)	9271 mm (30 ft 5 in)
Field position . . . . .	7366 mm (24 ft 2 in)	7670 mm (25 ft 2 in)
Height		
Transport position . . . . .	2032 mm (6 ft 8 in)	2032 mm (6 ft 8 in)
Field position . . . . .	1727 mm (5 ft 8 in)	1727 mm (5 ft 8 in)
Ground Clearance . . . . .	457 mm (18 in)	457 mm (18 in)
Wheel Tread Width . . . . .	3772 mm (148.5 in)	3772 mm (148.5 in)
Weight . . . . .	2948 kg (6500 lb)	2948 kg (6500 lb)

**SECTION 00 - GENERAL INFORMATION - CHAPTER 1**

---

**Driveline**

Tractor Requirement ..... 75 kW (100 Hp) or greater with standard category 2 or 3 ASAE hitch and PTO locations. Two remote hydraulic circuits capable of 104 bar (1500 psi).

Input Speed ..... 1000 rpm only

Drive ..... 1000 rpm PTO with slip clutch/overrunning clutch, enclosed gears and (3) HB banded belts with spring loaded idlers.

**Header**

Cutting Width ..... 4699 mm (15 ft 7 in)

Flotation ..... Vertical & radial

Windrow Width ..... 914 mm to 2438 mm (3 ft to 8 ft)

Header Lift ..... Hydraulic (master-slave system)

**Cutter Bar**

Type ..... Modular

No. of Discs ..... 8 counter-rotating, 4 co-rotating

Knives per Disc ..... 2

Disc Cutting Diameter ..... 500 mm (19.7 in)

Disc Drive ..... Bevel gears in sealed modules

Disc Speed ..... 3000 RPM

Cutting Height, Approximate ..... 24 mm - 81 mm (0.95 in - 3.20 in)

Cutting Bar Angle ..... -2° to -10°

**Conditioner**

Type ..... Intermeshing rolls

Drive ..... 4HB V-belt, enclosed gears with u-joint drives to upper & lower rolls.

**Rolls**

Type ..... Molded rubber with intermeshing spiral design.

Length ..... 2591 mm (102 in)

Diameter ..... 264 mm (10.38 in)

Speed ..... 740 rpm

Operating Speed ..... 0 to 14 km/h (0 to 9 mph)

Transport Speed ..... 32 km/h (20 mph) maximum

Capacity ..... 3.36 H/hr (8.97 A/hr) @ 10 km/h (6 mph) & 80% field efficiency.

Tire ..... 31.5 x 13.5L x 15, 6 ply tubeless agricultural rib implement tire

Tire Pressure ..... 207 kPa or 2.07 bar (30 psi).

Jack ..... 2000 lb capacity side-wind

Tongue Shift ..... Hydraulic

**SECTION 00 - GENERAL INFORMATION - CHAPTER 1**

---

**MODEL DC162**

	<b>Standard Tongue</b>	<b>Swivel Hitch Tongue</b>
<b>Overall Width</b>		
Transport position .....	4801 mm (15 ft 9 in)	4801 mm (15 ft 9 in)
Field position .....	7087 mm (23 ft 3 in)	7595 mm (24 ft 11 in)
<b>Overall Length</b>		
Transport position .....	8966 mm (29 ft 5 in)	9271 mm (30 ft 5 in)
Field position .....	7366 mm (24 ft 2 in)	7670 mm (25 ft 2 in)
<b>Height</b>		
Transport position .....	2032 mm (6 ft 8 in)	2032 mm (6 ft 8 in)
Field position .....	1727 mm (5 ft 8 in)	1727 mm (5 ft 8 in)
Ground Clearance .....	457 mm (18 in)	457 mm (18 in)
Wheel Tread Width .....	3772 mm (148.5 in)	3772 mm (148.5 in)
Weight .....	2894 kg (6380 lb)	2894 kg (6380 lb)
<b>Driveline</b>		
Tractor Requirement .....	74 kW (100 Hp) or greater with standard category 2 or 3 ASAE hitch and PTO locations. Two remote hydraulic circuits capable of 104 bar (1500 psi).	
Input Speed .....	1000 rpm only	
Drive .....	1000 rpm PTO with slip clutch/overrunning clutch, enclosed gears and (3) HB banded belts with spring loaded idlers.	
<b>Header</b>		
Cutting Width .....	4750 mm (15 ft 7 in)	
Flotation .....	Vertical & radial	
Windrow Width .....	914 mm to 2438 mm (3 ft to 8 ft)	
Header Lift .....	Hydraulic (master-slave system)	
<b>Cutter Bar</b>		
Type .....	Modular	
No. of Discs .....	8 counter-rotating, 4 co-rotating	
Knives per Disc .....	2	
Disc Cutting Diameter .....	500 mm (19.7 in)	
Disc Drive .....	Bevel gears in sealed modules	
Disc Speed .....	3000 rpm	
Cutting Height, Approximate .....	24 mm - 81 mm (0.95 in - 3.20 in)	
Cutting Bar Angle .....	-2° to -10°	
<b>Conditioner</b>		
Type .....	Flail	
Drive .....	4HB V-belt, enclosed gears with u-joint drives to rotor.	

*SECTION 00 - GENERAL INFORMATION - CHAPTER 1*

---

Rolls

Length ..... 2591 mm (102 in)  
Diameter ..... 560 mm (22 in)  
Speed ..... 1011 rpm (726 rpm optional)

Operating Speed ..... 0 to 14 km/h (0 to 9 mph)

Transport Speed ..... 32 km/h (20 mph) maximum

Capacity ..... 3.36 H/hr (8.97 A/hr) @ 10 km/h (6 mph) &  
80% field efficiency.

Tire ..... 31.5 x 13.5L x 15, 6 ply tubeless agricultural  
rib implement tire

Tire Pressure ..... 207 kPa or 2.07 bar (30 psi).

Jack ..... 2000 lb capacity side-wind

Tongue Shift ..... Hydraulic

**SECTION 00 - GENERAL INFORMATION - CHAPTER 1**

**RECOMMENDED LUBRICANTS AND COOLANTS**

<b>Lubricant</b>	<b>Type and Description</b>	<b>Part Number</b>	<b>Container Size</b>	
<b>Engine Oil</b>	AKCELA NO. 1 SSL OIL SAE 0W-40	B505693	2.5G / 9.46L	
	AKCELA NO. 1 OIL SAE 10W	407357R4	5G / 18.93L	
	AKCELA NO. 1 OIL SAE 10W-30	104104A1	1QT / .946L	
		139033A1	1G / 3.785L	
		372253A1	2.5G / 9.46L	
		104106A1	5G / 18.93L	
	AKCELA NO. 1 OIL SAE 30	407352R4	1QT / .946L	
		139032A1	1G / 3.785L	
		143947A1	2.5G / 9.46L	
		407356R4	5G / 18.93L	
	AKCELA NO. 1 OIL SAE 15W-40	407410R2	1QT / .946L	
		139034A1	1G / 3.785L	
		143949A1	2.5G / 9.46L	
		407414R2	5G / 18.93L	
	AKCELA NO. 1 OIL SAE 20W-50	332390A1	5G / 18.93L	
	AKCELA AUTO SUPREME SAE 5W-30	372255A1	1QT / .946L	
	AKCELA AUTO SUPREME SAE 10W-30	B500401	1QT / .946L	
	AKCELA LOW ASH OIL SAE 10W	407345R3	5G / 18.93L	
	AKCELA LOW ASH OIL SAE 30	407340R3	1QT / .946L	
		139037A1	1G / 3.785L	
		407344R3	5G / 18.93L	
	<b>Transmission Oil</b>	AKCELA HY-TRAN ULTRA	139029A2	1G / 3.785L
			143945A2	2.5G / 9.46L
		372705R7	5G / 18.93L	
AKCELA HY-TRAN ULTRA SSL		B505697	2.5G / 9.46L	
AKCELA TSM BIO		B505699	2.5G / 9.46L	
<b>Hydraulic Oil</b>	AKCELA AW46 HYD FLUID	116799A1	5G / 18.93L	
	AKCELA AW68 HYD FLUID	B505690	5G / 18.93L	
	AKCELA AW100 HYD FLUID	339852A1	5G / 18.93L	
	AKCELA HYDRAULIC EXCAVATOR FLUID	B17639	5G / 18.93L	
	AKCELA TCH FLUID	139030A1	1G / 3.785L	
		B53977	5G / 18.93L	
<b>ATF Oil</b>	TRANS. XHD	282371A1	1QT / .946L	
		310233A1	2.5G / 9.46L	
<b>Gear Oil</b>	AKCELA 135H EP GEAR LUBE SAE 80W-90	139039A1	1G / 3.785L	
		139801A1	5G / 18.93L	
		246666A1	16G / 60.6L	
	AKCELA 135H EP GEAR LUBE SAE 85W-140	139041A1	1G / 3.785L	
		407364R2	5G / 18.93L	
		407538R2	16G / 60.6L	
	AKCELA TRANSAXLE FLUID	B17632	5G / 18.93L	
AKCELA GEAR LUBE SSL	B505707	1QT / .946L		
<b>Grease</b>	AKCELA 251H EP MULTI-PURPOSE GREASE	132096A1	TUBE - 14 OZ.	
	AKCELA PREMIUM GREASE EP-2	B505708	TUBE - 14 OZ.	
	AKCELA EP-0 GREASE	B505226	3.35 OZ	
	AKCELA CORN HEAD GREASE	B95920	TUBE - 14 OZ.	
	AKCELA MOLY GREASE	132095A1	TUBE - 14 OZ.	
	AKCELA SSL SYNTHETIC GREASE	B505709	TUBE - 14 OZ.	
	AKCELA HTO ADDITIVE	B17508	1QT / .946L	
	AKCELA HTO PREMIX	298053A1	1G / 3.785L	
	AKCELA LIMITED SLIP ADDITIVE	B91246	16 OZ	
	AKCELA AXLE OIL ADDITIVE	402982A1	16 OZ	
<b>Brake Oil</b>	AKCELA CRAWLER BRAKE OIL	B91244	1QT / .946L	
<b>Special Lubricants</b>	AKCELA AG LUBRICANT	156576C91	1QT / .946L	
	AKCELA DURAFIT SPINDLE GREASE	B500418	35 LB. / 15.9L	
	AKCELA COTTON PICKER BAR LUBE	407515R1	35 LB. / 15.9L	
	AKCELA HI-SPEED SPINDLE CLEANER	B91241V	5G / 18.93L	

# MINIMUM HARDWARE TIGHTENING TORQUES

IN NEWTON-METERS (FOOT POUNDS) FOR NORMAL ASSEMBLY APPLICATIONS

## METRIC NON-FLANGED HARDWARE AND LOCKNUTS

NOMINAL SIZE	CLASS 5.8		CLASS 8.8		CLASS 10.9		LOCKNUT CL.8 W/CL8.8 BOLT
	UNPLATED	PLATED W/ZnCr	UNPLATED	PLATED W/ZnCr	UNPLATED	PLATED W/ZnCr	
M4	1.7 (15)*	2.2 (19)*	2.6 (23)*	3.4 (30)*	3.7 (33)*	4.8 (42)*	2.3 (20)*
M6	5.8 (51)*	7.6 (67)*	8.9 (79)*	12 (102)*	13 (115)*	17 (150)*	7.8 (69)*
M8	14 (124)*	18 (159)*	22 (195)*	28 (248)*	31 (274)*	40 (354)*	19 (169)*
M10	28 (21)	36 (27)	43 (32)	56 (41)	61 (45)	79 (58)	38 (28)
M12	49 (36)	63 (46)	75 (55)	97 (72)	107 (79)	138 (102)	66 (49)
M16	121 (89)	158 (117)	186 (137)	240 (177)	266 (196)	344 (254)	164 (121)
M20	237 (175)	307 (226)	375 (277)	485 (358)	519 (383)	671 (495)	330 (243)
M24	411 (303)	531 (392)	648 (478)	839 (619)	897 (662)	1160 (855)	572 (422)

NOTE: Torque values shown with \* are inch pounds.

### IDENTIFICATION HEX CAP SCREW AND CARRIAGE BOLTS CLASSES 5.6 AND UP

MANUFACTURER'S IDENTIFICATION

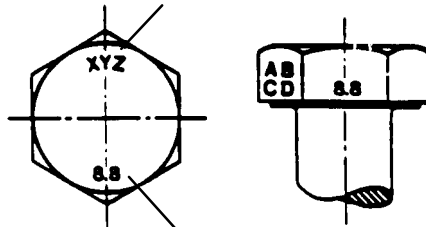

PROPERTY CLASS

### HEX NUTS AND LOCKNUTS CLASSES 05 AND UP

MANUFACTURER'S IDENTIFICATION

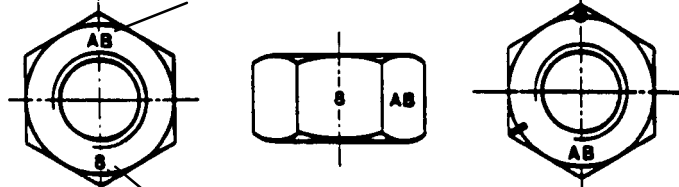

PROPERTY CLASS

CLOCK MARKING

# MINIMUM HARDWARE TIGHTENING TORQUES

IN NEWTON-METERS (FOOT POUNDS) FOR NORMAL ASSEMBLY APPLICATIONS

## INCH NON-FLANGED HARDWARE AND LOCKNUTS

NOMINAL SIZE	SAE GRADE 2		SAE GRADE 5		SAE GRADE 8		LOCKNUTS		NOMINAL SIZE
	UNPLATED or PLATED SILVER	PLATED W/ZnCr GOLD	UNPLATED or PLATED SILVER	PLATED W/ZnCr GOLD	UNPLATED or PLATED SILVER	PLATED W/ZnCr GOLD	GR.B w/GR5 BOLT	GR.C w/GR8 BOLT	
1/4	6.2 (55)*	8.1 (72)*	9.7 (86)*	13 (112)*	14 (121)*	18 (157)*	8.5 (75)*	12.2 (109)*	1/4
5/16	13 (115)*	17 (149)*	20 (178)*	26 (229)*	28 (250)*	37 (324)*	17.5 (155)*	25 (220)*	5/16
3/8	23 (17)	30 (22)	35 (26)	46 (34)	50 (37)	65 (48)	31 (23)	44 (33)	3/8
7/16	37 (27)	47 (35)	57 (42)	73 (54)	80 (59)	104 (77)	50 (37)	71 (53)	7/16
1/2	57 (42)	73 (54)	87 (64)	113 (83)	123 (91)	159 (117)	76 (56)	108 (80)	1/2
9/16	81 (60)	104 (77)	125 (92)	163 (120)	176 (130)	229 (169)	111 (82)	156 (115)	9/16
5/8	112 (83)	145 (107)	174 (128)	224 (165)	244 (180)	316 (233)	153 (113)	215 (159)	5/8
3/4	198 (146)	256 (189)	306 (226)	397 (293)	432 (319)	560 (413)	271 (200)	383 (282)	3/4
7/8	193 (142)	248 (183)	495 (365)	641 (473)	698 (515)	904 (667)	437 (323)	617 (455)	7/8
1	289 (213)	373 (275)	742 (547)	960 (708)	1048 (773)	1356 (1000)	654 (483)	924 (681)	1

NOTE: Torque values shown with \* are inch pounds.

### IDENTIFICATION CAP SCREWS AND CARRIAGE BOLTS



### LOCKNUTS

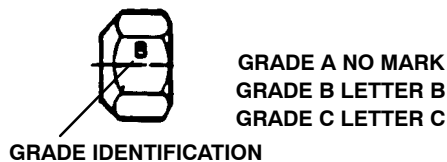
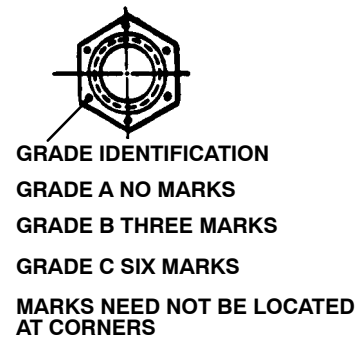
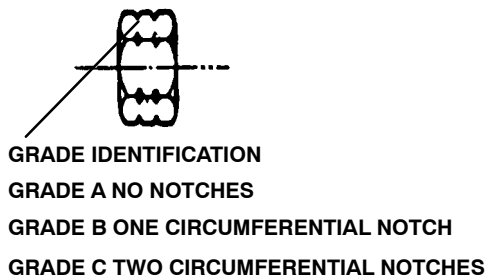

**INSTALLATION OF ADJUSTABLE FITTINGS IN STRAIGHT THREAD O-RING BOSSES**

1. Lubricate the O-ring by coating it with a light oil or petroleum. Install the O-ring in the groove adjacent to the metal backup washer which is assembled at the extreme end of the groove, 4.
2. Install the fitting into the SAE straight thread boss until the metal backup washer contacts the face of the boss, 5.

**NOTE:** Do not over tighten and distort the metal backup washer.

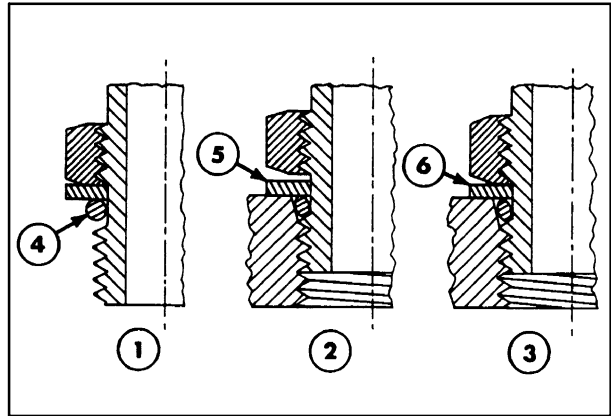

3. Position the fitting by turning out (counter-clockwise) up to a maximum of one turn. Holding the pad of the fitting with a wrench, tighten the locknut and washer against the face of the boss, 6.

**STANDARD TORQUE DATA FOR HYDRAULIC TUBES AND FITTINGS**

TUBE NUTS FOR 37° FLARED FITTINGS						O-RING BOSS PLUGS ADJUSTABLE FITTING LOCKNUTS, SWIVEL JIC - 37° SEATS					
TORQUE						TORQUE					
SIZE	TUBING OD		THREAD SIZE	POUND FOOT		NEWTON METERS		POUND FOOT		NEWTON METERS	
	In.	mm		Min.	Max.	Min.	Max.	Min.	Max.	Min.	Max.
4	1/4	6.4	7/16-20	9	12	12	16	6	10	8	14
5	5/16	7.9	1/2-20	12	15	16	20	10	15	14	20
6	3/8	9.5	9/16-18	21	24	29	33	15	20	20	27
8	1/2	12.7	3/4-18	35	40	47	54	25	30	34	41
10	5/8	15.9	7/8-14	53	53	72	79	35	40	47	54
12	3/4	19.1	1-1/16-12	77	82	104	111	60	70	81	95
14	7/8	22.2	1-3/16-12	90	100	122	136	70	80	95	109
16	1	25.4	1-5/16-12	110	120	149	163	80	90	108	122
20	1-1/4	31.8	1-5/8-12	140	150	190	204	95	115	129	158
24	1-1/2	38.1	1-7/8-12	160	175	217	237	120	140	163	190
32	2	50.8	2-1/2-12	225	240	305	325	250	300	339	407

These torques are not recommended for tubes of 1/2 inch (12.7 mm) OD and larger with wall thickness of 0.035 inch (0.889 mm) or less. The torque is specified for 0.035 inch (0.889 mm) wall tubes on each application individually.

Before installing and torquing 37° flared fittings, clean the face of the flare and threads with a clean

solvent or Loctite cleaner and apply hydraulic sealant Loctite™ no. 569 to the 37° flare and the threads.

Install fitting and torque to specified torque, loosen fitting and retorquing to specifications.

### PIPE THREAD FITTING TORQUE

Before installing and tightening pipe fittings, clean the threads with a clean solvent or Loctite cleaner and apply sealant Loctite no. 567 for all fittings including stainless steel or no. 565 for most metal fittings. For high filtration/zero contamination systems use no. 545.

Thread Size	Torque (Maximum)
1/8 inch - 27	13 N·m (10 lb ft)
1/4 inch - 18	16 N·m (12 lb ft)
3/8 inch - 14	22 N·m (16 lb ft)
1/2 inch - 14	41 N·m (30 lb ft)
3/4 inch - 14	54 N·m (40 lb ft)

### INSTALLATION OF ORFS (O-RING FLAT FACED) FITTINGS

When installing ORFS fittings thoroughly clean both flat surfaces of the fittings, 1, and lubricate the O-ring, 2, with light oil. Make sure both surfaces are aligned properly. Torque the fitting to specified torque listed throughout the service manual.

**IMPORTANT:** If the fitting surfaces are not properly cleaned, the O-ring will not seal properly. If the fitting surfaces are not properly aligned, the fittings may be damaged and will not seal properly.

**IMPORTANT:** Always use genuine Case IH replacement oils and filters to ensure proper lubrication and filtration of engine and hydraulic system oils.

The use of proper oils, grease, and keeping the hydraulic system clean will extend machine and component life.

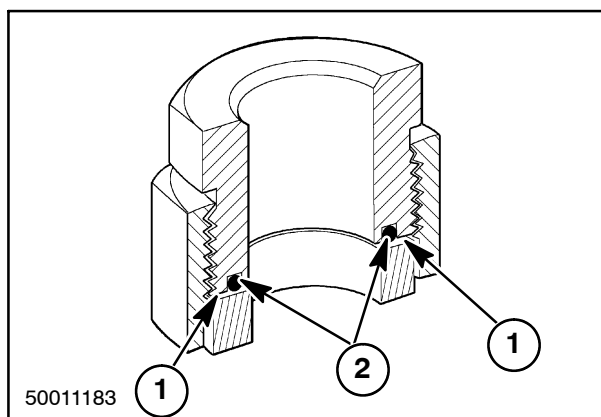

## SECTION 31 - IMPLEMENT POWER TAKE OFF (PTO)

### Chapter 1 - Drive Lines (Standard Tongue)

#### CONTENTS

Section	Description	Page
	DC162 Swivel Hitch Driveline .....	3
	Introduction .....	3
	Primary PTO .....	4
	Front Half Removal .....	4
	Front Half Installation .....	4
	Rear Half Removal .....	4
	Rear Half Installation .....	5
	Intermediate PTO .....	5
	Front Half Removal .....	5
	Front Half Installation .....	6
	Rear Half Removal .....	7
	Rear Half Installation .....	7
	Jackshaft .....	8
	Removal .....	8
	Disassembly .....	9
	Inspection .....	9
	Assembly .....	9
	Installation .....	10
	Secondary PTO .....	11
	Front Half Removal .....	11
	Front Half Installation .....	11
	Rear Half Removal .....	11
	Rear Half Installation .....	11
	Slide Lock .....	14
	Disassembly .....	14
	Assembly .....	14
	Auto-Lok Slide Lock .....	17
	Auto-Lok Slide Lock - Disassembly .....	17
	Auto-Lok Slide Lock - Assembly .....	18
	Standard Driveline Guards - Disassembly .....	19
	Secondary Driveline Guards - Disassembly .....	20
	Standard Driveline Guards .....	21

*SECTION 31 - IMPLEMENT POWER TAKE OFF (PTO) - CHAPTER 1*

---

<b>Section</b>	<b>Description</b>	<b>Page</b>
	Disassembly .....	21
	Reassembly .....	21
	U-Joints: Swivel Hitch Units .....	22
	Disassembly .....	22
	Reassembly .....	25

## DC162 SWIVEL HITCH DRIVELINE

### INTRODUCTION

The primary PTO, 1, on the swivel hitch models uses a pair of U-joints to transfer power from the tractor to the lower swivel hitch gearbox. The U-joints are located at the tractor end of the primary PTO shaft, 2, and lower gearbox end, 3, allowing the tractor to turn the driveline during PTO operation.

The lower swivel hitch gearbox turns the upper gearbox, which transfers power to the intermediate PTO.

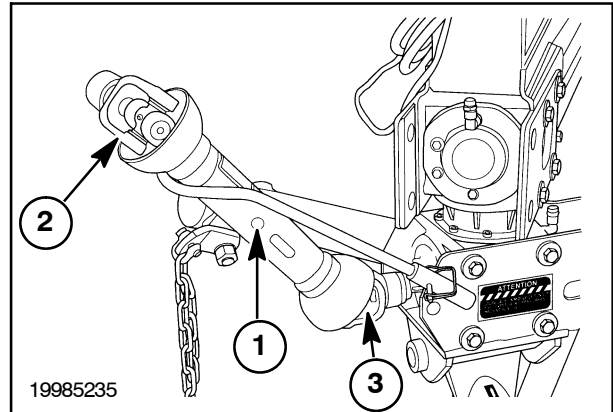

1

The intermediate PTO, 1, runs from the upper gearbox, 2, to a point midway along the tongue. The intermediate PTO uses a clamp yoke, 3, at the gearbox end and attaches to the jackshaft, 4, using a slip clutch assembly, 5.

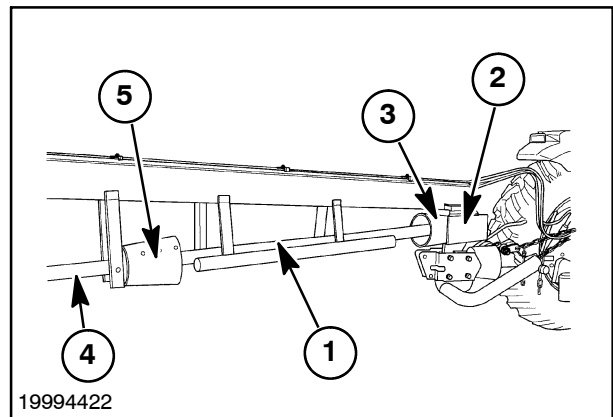

2

The secondary PTO shaft, 1, attaches to the rear of the jackshaft, 2, using an Auto-Lok yoke, 3, and attaches to the center gearbox, 4, using a clamp hub assembly, 5.

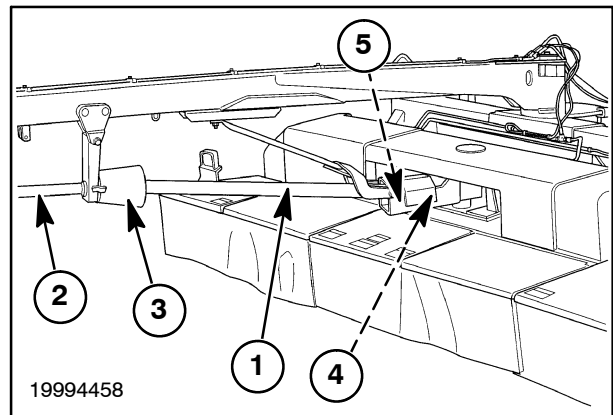

3

## PRIMARY PTO

### Front Half Removal

**IMPORTANT:** The PTO shafts are very heavy and awkward; use caution not to drop the shaft assemblies as personal injury or damage to the components may result.

1. To service the front half of the primary PTO, 1, pull the front half from the rear half, 2, of the primary PTO.

Refer to the Slide Lok, Driveline Guards, and U-joints sections in this manual to service the front half of the primary PTO.

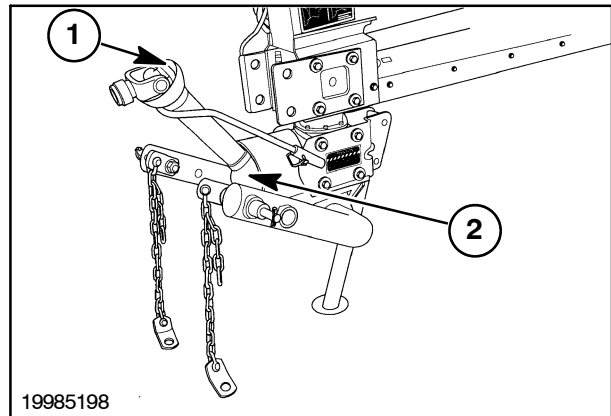

4

### Front Half Installation

Align the female splines on the front half of the primary PTO with the male splines on the rear half of the primary PTO and slide the two shafts together.

**NOTE:** Ensure the shields fit together properly and the two halves telescope freely.

### Rear Half Removal

**IMPORTANT:** The PTO shafts are very heavy and awkward; use caution not to drop the shaft assemblies as personal injury or damage to the components may result.

1. To service the rear half of the primary PTO, 1, pull the front half, 2, from the rear half of the primary PTO.
2. Remove the protective shielding by squeezing the sides together until they release from the retaining pins.
3. Pull back the slide lock, 3, and slide the primary PTO off the lower swivel gearbox.
4. Refer to the Slide Lok, Driveline Guards, and U-joints sections in this manual to service the rear half of the primary PTO.

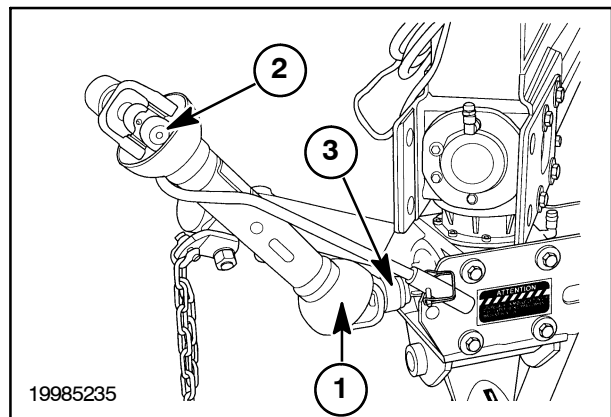

5

### Rear Half Installation

1. Pull back the slide lock, 1, and slide the primary PTO on the lower swivel gearbox.
2. Install the protective shielding by squeezing the sides together until the mounting holes align with the retaining pins, and release the shield.
3. Align the female splines on the front half, 2, of the primary PTO with the male splines on the rear half, 3, of the primary PTO and slide the two shafts together.

**NOTE:** Ensure the shields fit together properly and the two halves telescope freely.

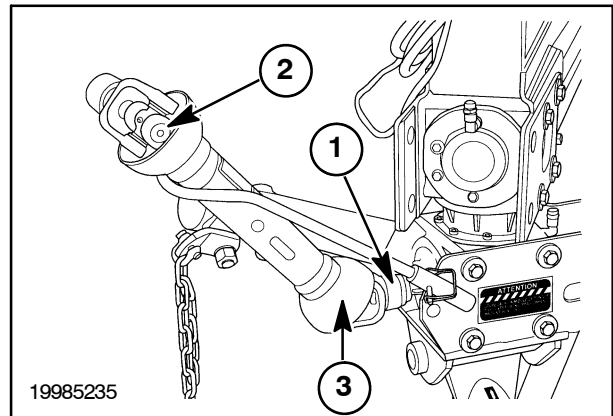

6

### INTERMEDIATE PTO

#### Front Half Removal

**IMPORTANT:** The PTO shafts are very heavy and awkward; use caution not to drop the shaft assemblies as personal injury or damage to the components may result.

1. Remove the protective shielding, 1, by squeezing the sides together until they release from the retaining pins. Slide the shield rearward on the shaft to gain access to the retaining bolts.
2. Remove the two 1/2 inch x 3 inch yoke bolts, 1, and lock nuts from the clamp yoke, 2, and slide the intermediate PTO off the upper swivel gearbox output shaft.
3. To service the front half, 3, of the intermediate PTO pull the front half from the rear half of the primary PTO.
4. Refer to the Slide Lok, Driveline Guards, and U-joints sections in this manual to service the rear half of the primary PTO.

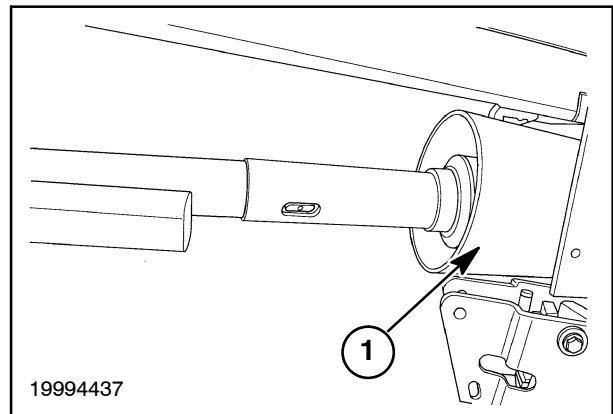

7

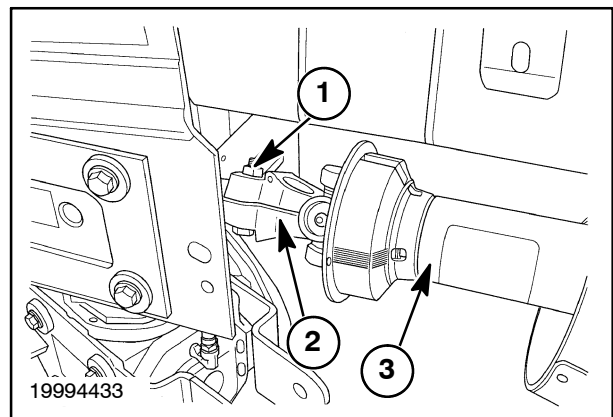

8

**Front Half Installation**

1. Align the male yoke shaft on the front half, 1, of the intermediate PTO with the female yoke tube on the rear half of the intermediate PTO and slide the two shafts together.

**NOTE:** In the female yoke tube of the intermediate PTO there is a phase, the male yoke shaft will only fit in two positions.

2. Install the intermediate PTO, shield and position over the PTO with the small end of the shield facing the gearboxes.

**NOTE:** Ensure the shields fit together properly and the two halves telescope freely.

3. Slide the intermediate PTO onto the upper gearbox output shaft until the clamp yoke bolt holes align with the groove in the output shaft.
4. Install the two 1/2 inch x 3 yoke bolts, 2, and lock nuts. Torque to 159 N·m (117 lb ft).
5. Install the protective shielding by squeezing the sides together until the mounting holes align with the retaining pins, and release the shield.

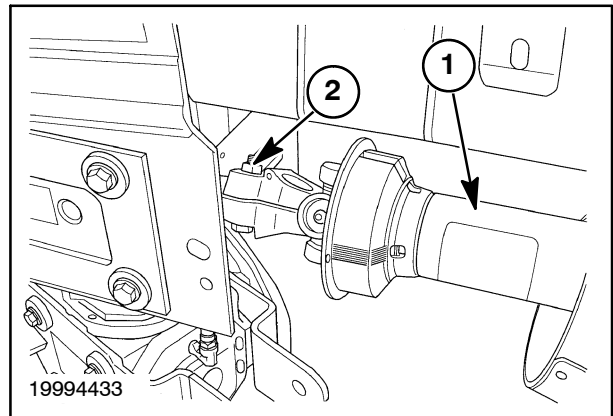



**Suggest:**

**For more complete manuals. Please go to the home page.**

**<https://www.ebooklibonline.com>**

**If the above button click is invalid. Please download this document first, and then click the above link to download the complete manual.**

**Thank you so much for reading**

### Rear Half Removal

**IMPORTANT:** The PTO shafts are very heavy and awkward; use caution not to drop the shaft assemblies as personal injury or damage to the components may result.

1. Remove the protective shielding by pulling one side of shield from the retaining pin, then pull the other side from the retaining pin. Slide the shield rearward on the shaft to gain access to the retaining bolts.
2. Remove the two 1/2 inch x 2 inch yoke bolts, 1, and lock nuts from the slip clutch shaft, 2, and slide the intermediate PTO off the splined shaft.

**NOTE:** Use caution not to loose the spacer, 3, and shims when removing the rear half of the PTO.

3. Pull the rear half of the intermediate PTO from the front half.
4. Refer to the Driveline Guards, U-joints sections, and the Slip Clutch sections in this manual to service the rear half of the intermediate PTO.

### Rear Half Installation

1. Align the male yoke shaft on the front half of the intermediate PTO with the female yoke tube on the rear half of the intermediate PTO and slide the two shafts together.

**NOTE:** In the female yoke tube of the intermediate PTO there is a phase, the male yoke shaft will only fit in two positions.

2. Slide the intermediate PTO onto the splined shaft until the clamp yoke bolt holes align with the groove in the shaft.
3. Install the two 1/2 inch x 2 inch yoke bolts, 1, Figure 10, and lock nuts from the slip clutch shaft. Torque to 159 N·m (117 lb ft).
4. Install the protective shielding by pulling one side of shield on the retaining pin, and then pull the other side on the retaining pin.

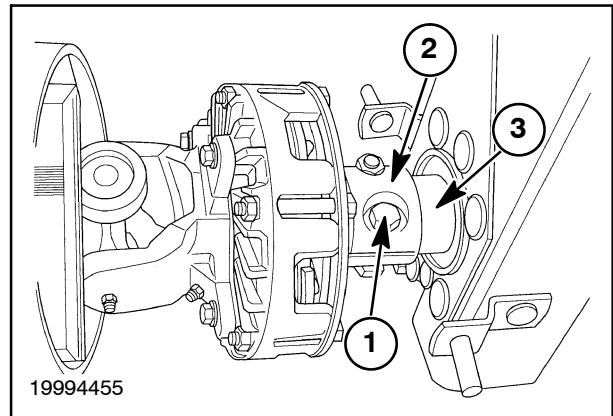

## JACKSHAFT

### Removal

1. Remove the intermediate PTO, 1, from the jackshaft, as described earlier in this section.
2. Remove the five 1/2 inch-13 carriage bolts and one 1/2 inch-13 cap screw, 2, and nuts, 3, from the flangettes, 4, and bracket, 5.

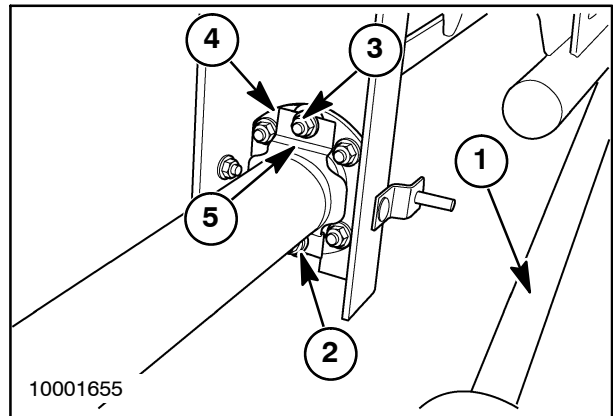

11

3. Remove the protective shielding by pulling one side of shield from the retaining pin, then pull the other side from the retaining pin. Slide the shield rearward on the shaft to gain access to the retaining bolts.
4. Pull back on the auto lock collar, 1, and pull the secondary PTO, 2, from the jackshaft.
5. Remove the six 1/2 inch-13 carriage bolts and nuts, 3, from the flangettes, 4.

**NOTE:** There are two 1/2 inch flat washers installed between the shield bracket and flangette at the slot in the support.

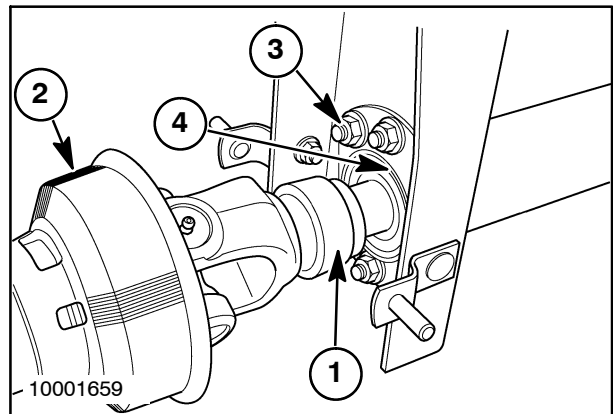

12

**IMPORTANT:** The PTO shafts are very heavy and awkward; use caution not to drop the shaft assemblies as personal injury or damage to the components may result.

6. Support the entire jackshaft and shift the jackshaft towards the cutter bar, then lower the jackshaft to the ground.

**<https://www.ebooklibonline.com>**

Hello dear friend!

Thank you very much for reading.

Enter the link into your browser.

The full manual is available for immediate download.

**<https://www.ebooklibonline.com>**