

DC132 Disc Mower-Conditioner

Service Manual

84207370 3/09
1st Printing



DC132 SERVICE MANUAL CONTENTS

SECTION 00 - GENERAL INFORMATION

**SECTION 31 - IMPLEMENT POWER TAKE-OFF
(PTO)**

SECTION 35 - HYDRAULIC SYSTEM

SECTION 39 - FRAMES/TONGUE AND HITCHES

SECTION 55 - ELECTRICAL SYSTEM

SECTION 58 - ATTACHMENTS/HEADERS

SECTION 90 - DECALS

The sections used through out all Case IH product Service manuals may not be used for each product. Each Service manual will be made up of one or several books. Each book will be labeled as to which sections are in the overall Service manual and which sections are in each book.

The sections listed above are the sections utilized for the DC132.

COMPLETE CONTENTS

SECTION 00 - GENERAL INFORMATION

Chapter 1 - General Information

CONTENTS

Section	Description	Page
	Special Tools	2
	Specifications	4
	Center-Pull Disc Mower Conditioner	4
	Lubrication	5
	General Information	5
	Grease Fittings	5
	Chains	5
	Recommended Lubricants and Coolants	6
	Minimum Hardware Tightening Torques	7
	Installation of Adjustable Fittings in Straight Thread O-Ring Bosses	9
	Standard Torque Data for Hydraulic Tubes and Fittings	9
	Pipe Thread Fitting Torque	10
	Installation of ORFS (O-ring Flat Faced) Fittings	10

<https://www.ebooklibonline.com>

Hello dear friend!

Thank you very much for reading.

Enter the link into your browser.

The full manual is available for immediate download.

<https://www.ebooklibonline.com>

SECTION 31 - IMPLEMENT POWER TAKE OFF (PTO)

Chapter 1 - Drive Lines (Standard Tongue)

CONTENTS

Section	Description	Page
	DC132 Standard Tongue	2
	Introduction	2
	Auto-Lok Slide Lock	3
	Disassembly	3
	Assembly	5
	Drive Shaft Removal and Installation	6
	Standard Driveline Guards - Disassembly	9
	Primary Driveline Guards - Disassembly	10
	Driveline Guards - Inspection	11
	Secondary Driveline Guards - Assembly	11
	80° CV Front Guard Assembly	12
	CV/U-Joints	13
	Disassembly	13
	Inspection	14
	Assembly	15
	Tongue Jackshaft	16
	Disassembly	16
	Assembly	18

SECTION 31 - IMPLEMENT POWER TAKE OFF (PTO)

Chapter 2 - Drive Lines (Swivel Hitch Tongue)

CONTENTS

Section	Description	Page
	DC132 Swivel Hitch Driveline	2
	Introduction	2
	Slide Lock	3
	Disassembly	3
	Assembly	4
	Drive Shaft	6
	Removal	6
	Standard Driveline Guards	9
	Disassembly	9
	Reassembly	10
	U-joints: Swivel Hitch Units	10
	Disassembly	10
	Reassembly	13
	Tongue Jackshaft	15
	Disassembly	15
	Installation	16

SECTION 31 - IMPLEMENT POWER TAKE OFF (PTO)

Chapter 3 - Slip Clutch

CONTENTS

Section	Description	Page
	Introduction	2
	Slip Clutch Run-In	2
	Slip Clutch Wear Inspection	3
	Slip Clutch	3
	Removal	3
	Disassembly	4
	Inspection	5
	Reassembly	5
	Installation	9

SECTION 31 - IMPLEMENT POWER TAKE OFF (PTO)

Chapter 4 - Overrunning Clutch

CONTENTS

Section	Description	Page
	Overrunning Clutch	2
	Disassembly	2
	Inspection	3
	Assembly	3

SECTION 31 - IMPLEMENT POWER TAKE OFF (PTO)

Chapter 5 - Gearbox (Swivel Hitch)

CONTENTS

Section	Description	Page
	Introduction	2
	Special Tools	2
	Overhaul	6
	Swivel Hitch Gearboxes	6
	Description	6
	Removal	7
	Disassembly	10
	Neck Disassembly	12
	Neck Assembly	16
	Upper Gear Box	21
	Disassembly	21
	Inspection	22
	Assembly	22
	Upper Gearbox and Neck Assembly	24
	Assembly	24
	Backlash Adjustment	25
	Gear Contact Pattern	28
	Lower Gear Box	33
	Disassembly	33
	Inspection	34
	Assembly	34
	Lower Gearbox and Neck Assembly	36
	Assembly	36
	Backlash Adjustment	37
	Gear Contact Pattern	40
	Lower Gearbox, Neck Assembly, and Upper Gearbox	45
	Assembly	45
	Swivel Hitch Gearbox Installation	46

SECTION 35 - HYDRAULIC SYSTEM

Chapter 1 - Cylinders

CONTENTS

Section	Description	Page
	Introduction	2
	Hydraulic Diagram	4
	Bleeding Air from the Lift Cylinders	5
	Lift Cylinder Removal	6
	Master Cylinder	7
	Disassembly	7
	Inspection	8
	Assembly	8
	Slave Cylinder	9
	Disassembly	9
	Inspection	10
	Assembly	10
	Header Tilt Cylinder	11
	Removal	11
	Disassembly	12
	Assembly	14
	Installation	17
	Tongue Swing Cylinder	19
	Removal	19
	Disassembly	20
	Assembly	21
	Installation	23

SECTION 39 - FRAMES/TONGUE AND HITCHES

Chapter 1 - Hood and Hood Liner

CONTENTS

Section	Description	Page
	Hood	2
	Removal	2
	Installation	5
	Hood Liner	7
	Removal	7
	Installation	8

SECTION 55 - ELECTRICAL SYSTEM

Chapter 1 - Implement Lights

CONTENTS

Section	Description	Page
	Introduction	2
	Trailing Lights	3
	Description	4
	Installing #9603575 Socket	5
	Trailer Connector Repair	7
	Lighting Control Box	8
	Removal and Installation	8
	Model DC132 Wiring Schematic	9

SECTION 58 - ATTACHMENTS/HEADERS

Chapter 1 - Cutter Bar

CONTENTS

Section	Description	Page
	Special Tools	2
	Introduction	2
	Discs	5
	Knife and Bolt Inspection	6
	Disc Knives	7
	7 Degree Twist Knives	7
	14 Degree Twist Knives	7
	V Knives	7
	Knife Replacement	8
	Crop Lifter Replacement	10
	Rock Guards	11
	Skid Shoes	11
	Cutter Bar Inspection/Failure Analysis	12
	Top Cap	15
	Removal	15
	Inspection	16
	Installation	16
	Cutter Bar	19
	Removal	19
	Installation	21
	Cutter Bar Bayonet Bushing	22
	Replacement	22
	Cutter Bar	23
	Disassembly	23
	Reassembly	24
	Disc Module	28
	Disassembly	28
	Assembly	30
	Cutter Bar Drive Shaft	34
	Removal	34
	Disassembly	35
	Assembly	37

SECTION 58 - ATTACHMENTS/HEADERS

Chapter 2 - Left Pedestal Shaft

CONTENTS

Section	Description	Page
	Left Pedestal Shaft	2
	Disassembly	2
	Assembly	4

SECTION 58 - ATTACHMENTS/HEADERS

Chapter 3 - Gearbox (Center Pivot)

CONTENTS

Section	Description	Page
	Center Pivoting Gearbox	2
	Removal	2
	Disassembly	4
	Parts identification	7
	Inspection	8
	Assembly	8
	Backlash Adjustment	12
	Gear Contact Pattern	13
	Gearbox Support Plate Bushing Replacement	15
	Center Pivoting Gearbox	16
	Installation	16
	Guidance Link Shimming	19

SECTION 58 - ATTACHMENTS/HEADERS

Chapter 4 - Gearbox (Right Hand)

CONTENTS

Section	Description	Page
	Right-hand Gearbox	2
	Removal	2
	Disassembly	6
	Inspection	10
	Parts Identification	11
	Assembly	12
	Backlash Adjustment	17
	Gear Contact Pattern	18
	Installation	20

SECTION 58 - ATTACHMENTS/HEADERS

Chapter 5 - Gearbox (Conditioner Drive DC132)

CONTENTS

Section	Description	Page
	Conditioner Drive Gearbox	2
	Removal	2
	Disassembly	4
	Inspection	5
	Assembly	6
	Installation	9
	Gearbox Specifications	13
	Pivot Gearbox	13
	Right-Hand Gearbox	13
	Conditioner Drive Gearbox	13

SECTION 58 - ATTACHMENTS/HEADERS

Chapter 6 - Conditioner Rolls and Drive (DC132)

CONTENTS

Section	Description	Page
	Introduction	2
	Conditioner Belt	3
	Adjustment	3
	Replacement	4
	Conditioner Roll Drive Shaft	4
	Removal	4
	Disassembly	6
	Assembly	7
	Installation	8
	Lower Conditioner Roll	10
	Removal	10
	Installation	14
	Upper Conditioner Roll	17
	Removal	17
	Installation	20
	Conditioner Roll Tension System	22
	Left Side Torsion Arm and Bar Disassembly	22
	Right Side Torsion Arm, Torsion Bar and Adjusting Tube Disassembly	24
	Conditioner Roll Tension System - Assembly	26
	Right Side Torsion Arm, Torsion Bar and Adjusting Tube Assembly	26
	Left Side Torsion Arm and Bar Assembly	29

SECTION 58 - ATTACHMENTS/HEADERS

Chapter 7 - Conditioner Flail and Drive

CONTENTS

Section	Description	Page
	Special Tools	2
	Conditioner Belt	3
	Replacement	3
	Flail	4
	Removal	4
	Installation	6
	Rotor	7
	Removal	7
	Installation	12
	Conditioner Drive Shaft – Removal	17
	Conditioner Drive Shaft – Disassembly	18
	Conditioner Drive Shaft – Assembly	20
	Conditioner Drive Shaft – Installation	21
	Drive Shaft Bearing – Removal	22
	Drive Shaft Bearing – Disassembly	23
	Drive Shaft Bearing – Assembly	26
	Drive Shaft Bearing – Installation	28

SECTION 90 - DECALS

Chapter 1 - Decals

CONTENTS

Section	Description	Page
	Safety Decals	2

SECTION 00 - GENERAL INFORMATION

Chapter 1 - General Information

CONTENTS

Section	Description	Page
	Special Tools	2
	Specifications	4
	Center-Pull Disc Mower Conditioner	4
	Lubrication	5
	General Information	5
	Grease Fittings	5
	Chains	5
	Recommended Lubricants and Coolants	6
	Minimum Hardware Tightening Torques	7
	Installation of Adjustable Fittings in Straight Thread O-Ring Bosses	9
	Standard Torque Data for Hydraulic Tubes and Fittings	9
	Pipe Thread Fitting Torque	10
	Installation of ORFS (O-ring Flat Faced) Fittings	10

SPECIAL TOOLS

Tool Number	Description/Use
Section 31	
NHO1386	Pivot tongue gearbox neck cap screws
610R	Snap ring remover
Local Manufacture	Neck lock nut removal
Local Manufacture	Holding tool for neck housing
Local Manufacture	Neck rolling torque measurement
Section 58	
FNH23ET95	Top cap bearing cover
FNH01221-2	Cutter bar tie bolt holding tool
FNH01221-3	Cutter bar wrench

SPECIFICATIONS

CENTER-PULL DISC MOWER CONDITIONER

MODEL	DC132	DC132 with Flails
Cutter Bar		
Cutting width	4.0 mm (13 ft 0 in)	4.0 mm (13 ft 0 in)
Cutting height	24 - 81 mm (0.95 - 3.2 in)	
Cutting height w/opt. high-stubble shoes	58 - 115 mm (2.25 - 4.5 in)	
Cutter bar tilt angle, degrees	2 - 10	
Type cutterbar	Modular	
Number of discs/Knives per disc	10/2	10/2
Disc speed @ rated PTO speed	3000 rpm	
Cutter bar shear protection	Std.- Frangible splines in disc drive hub	
Cutter bar flotation	Vertical and lateral, adjustable springs	
Conditioner		
Type	Spiral intermeshing molded rubber rolls	Flail Rotor w/100 tapered flails
Length	2591 mm (102 in)	2591 mm (102 in)
Diameter	264 mm (2 x 10.4 in) rolls	560 mm (1 x 22 in) flail rotor
Drive	4 HB v-belt & enclosed gears	4 HB v-belt
Speed, rpm	740	1011 std. or 726 opt.
Conditioning Roll Tension Adjustment	Single crank	NA
Conditioner gap adjustment	Drawbolt stop, each end	Single crank adjustment of rotor hood
Swath width	2.4 m (8 ft)	2.4 m (8 ft)
Windrow width	.9 - 2.4 m (3 - 8 ft)	.9 - 2.4 m (3 - 8 ft)
Driveline		
Input speed, rpm	1000	
Driveline protection	Slip Clutch and Overrunning Clutch Assembly @ rear of PTO shaft	
Tractor Requirements		
Minimum PTO power required	67 kW (90 Hp)	67 kW (90 Hp)
PTO shaft spline/size requirements	21-spline/1-3/8 inch	21-spline/1-3/8 inch
Hydraulic circuits required	2	
Minimum relief pressure required	103 bar (1500 psi)	
Electrical	7-pin electrical connector for transport lights	
Drawbar/3-pt Hitch	ASAE Cat. II or III drawbar or Cat. III 3-pt hitch	

SECTION 00 - GENERAL INFORMATION - CHAPTER 1

MODEL	DC132	DC132 with Flails
Tires		
Tubless Ag rib implement tires	31 x 13.5-15 8PR	
Transport Speed, Maximum, mph	20 (32)	
Dimensions and Weight		
Width, transport	4.0 m (13 ft 2 in)	
Width, operating	5.9 m 19 ft 5 in) w/std drawbar hitch; 6.5 m (21 ft 3 in) w/2-pt swivel hitch; 5.9 m (19 ft 7 in) w/drawbar swivel hitch	
Length, transport *	7.2 m (24 ft 7 in) w/std drawbar hitch; 8.1 m (26 ft 5 in) w/2-pt swivel hitch; 7.4 m (25 ft 5 in) w/drawbar swivel hitch	7.6 m (25 ft 1 in) w/std drawbar hitch; 8.2 m (26 ft 11 in) w/2-pt swivel hitch; 7.9 m (25 ft 11 in) w/drawbar swivel hitch
Length, operating *	5.8 m (20 ft 2 in) w/std. drawbar hitch; 6.7 m (22 in 1 ft) w/2-pt swivel hitch; 6.4 m (21 ft 1 in) w/drawbar swivel hitch	6.3 m (20 ft 8 in) w/std. drawbar hitch; 6.9 m (22 ft 7 in) w/2-pt swivel hitch; 6.6 m (21 ft 7 in) w/drawbar swivel hitch
Height, transport	2.0 m (6 ft 8 in)	
Height, operating	1.7 m (5 ft 8 in)	
Ground clearance w/header fully raised	457 mm (18 in)	
Weight, Shipping	w/Std. Tongue 2771 kg (6110 lb); w/2pt or dbr 2899 kg (6390 lb); w/steel (CIH) add 45 kg (100 lb)	w/Std. Tongue 2722 kg (6000 lb); w/2pt or dbr 2849 kg (6280 lb)
Weight, Operating	w/Std. Tongue 2631 kg (5800 lb); w/2pt or dbr 2758 kg (6080 lb); w/steel (CIH) add 45 kg (100 lb)	w/Std. Tongue 2576 kg (5680 lb); w/2pt or dbr 2703kg 5960 lb)
* Windrow shields fully open for length in both transport and operating positions. Flail curtain is down for all height and length measurements.		
Length with flail curtain up should be reduced by 152mm (6 in). Height with flail curtain up should be increased by 279mm (11 in).		

LUBRICATION

Adequate lubrication and maintenance on a regular schedule is vital to maintaining your equipment. To ensure long service and efficient operation, follow the lubrication and maintenance schedules outlined in this manual. The use of proper fuels, oils, grease and filters, as well as keeping the systems clean, will also extend machine and component life.

IMPORTANT: Always use genuine **Case IH** replacement parts, oils and filters to ensure proper operation, filtration of engine and hydraulic systems. See your **Case IH** dealer for additional oil quantities.

GENERAL INFORMATION

Regular lubrication is the best insurance against delays and repairs. Proper lubrication will extend machine life. Refer to the following charts for lubricants and service intervals.

IMPORTANT: Failure to complete the required maintenance at the recommended intervals can cause unnecessary downtime.

The intervals listed in the Lubrication Chart are guidelines to be used when operating in normal conditions. Adjust the intervals for operating in adverse environmental and working conditions. The intervals should be shortened for sandy, dusty and extremely hot operating conditions.

CAUTION

Observe the following safety precautions before performing any lubrication or maintenance:

- Shut off engine.
- Disengage all drives.
- Engage park brake.
- Lower all attachments to the ground or raise and engage all safety locks.
- Close all shields that are opened and reinstall any shields removed for lubrication and maintenance purposes.

Failure to comply may result in minor or moderate injury.

M1460

CAUTION

Some illustrations in this manual show shields opened or removed to display areas being serviced. Replace all shields before operating the machine. Failure to comply could result in death or serious injury.

M1213

Always clean the area around dipsticks, fill caps, and check plugs when checking fluid levels. Failure to clean these areas may allow contamination to enter the system. Drain, flush and refill the system anytime you suspect it is contaminated.

Grease Fittings

Wipe dirt from fittings before greasing.

Pump fresh grease into fitting to adequately lubricate the component and force out any contamination from the grease passage.

Wipe off excess grease.

Use a grease gun containing clean high grade of multipurpose grease.

Chains

Stop all drives before lubricating chains.

SECTION 00 - GENERAL INFORMATION - CHAPTER 1

RECOMMENDED LUBRICANTS AND COOLANTS

Lubricant	Type and Description	Part Number	Container Size	
Engine Oil	AKCELA NO. 1 SSL OIL SAE 0W-40	B505693	2.5G / 9.46L	
	AKCELA NO. 1 OIL SAE 10W	407357R4	5G / 18.93L	
	AKCELA NO. 1 OIL SAE 10W-30	104104A1	1QT / .946L	
		139033A1	1G / 3.785L	
		372253A1	2.5G / 9.46L	
		104106A1	5G / 18.93L	
	AKCELA NO. 1 OIL SAE 30	407352R4	1QT / .946L	
		139032A1	1G / 3.785L	
		143947A1	2.5G / 9.46L	
		407356R4	5G / 18.93L	
	AKCELA NO. 1 OIL SAE 15W-40	407410R2	1QT / .946L	
		139034A1	1G / 3.785L	
		143949A1	2.5G / 9.46L	
		407414R2	5G / 18.93L	
	AKCELA NO. 1 OIL SAE 20W-50	332390A1	5G / 18.93L	
	AKCELA AUTO SUPREME SAE 5W-30	372255A1	1QT / .946L	
	AKCELA AUTO SUPREME SAE 10W-30	B500401	1QT / .946L	
	AKCELA LOW ASH OIL SAE 10W	407345R3	5G / 18.93L	
	AKCELA LOW ASH OIL SAE 30	407340R3	1QT / .946L	
		139037A1	1G / 3.785L	
		407344R3	5G / 18.93L	
	Transmission Oil	AKCELA HY-TRAN ULTRA	139029A2	1G / 3.785L
			143945A2	2.5G / 9.46L
		372705R7	5G / 18.93L	
AKCELA HY-TRAN ULTRA SSL		B505697	2.5G / 9.46L	
AKCELA TSM BIO		B505699	2.5G / 9.46L	
Hydraulic Oil	AKCELA AW46 HYD FLUID	116799A1	5G / 18.93L	
	AKCELA AW68 HYD FLUID	B505690	5G / 18.93L	
	AKCELA AW100 HYD FLUID	339852A1	5G / 18.93L	
	AKCELA HYDRAULIC EXCAVATOR FLUID	B17639	5G / 18.93L	
	AKCELA TCH FLUID	139030A1	1G / 3.785L	
		B53977	5G / 18.93L	
ATF Oil	TRANS. XHD	282371A1	1QT / .946L	
		310233A1	2.5G / 9.46L	
Gear Oil	AKCELA 135H EP GEAR LUBE SAE 80W-90	139039A1	1G / 3.785L	
		139801A1	5G / 18.93L	
		246666A1	16G / 60.6L	
	AKCELA 135H EP GEAR LUBE SAE 85W-140	139041A1	1G / 3.785L	
		407364R2	5G / 18.93L	
		407538R2	16G / 60.6L	
	AKCELA TRANSAXLE FLUID	B17632	5G / 18.93L	
AKCELA GEAR LUBE SSL	B505707	1QT / .946L		
Grease	AKCELA 251H EP MULTI-PURPOSE GREASE	132096A1	TUBE - 14 OZ.	
	AKCELA PREMIUM GREASE EP-2	B505708	TUBE - 14 OZ.	
	AKCELA EP-0 GREASE	B505226	3.35 OZ	
	AKCELA CORN HEAD GREASE	B95920	TUBE - 14 OZ.	
	AKCELA MOLY GREASE	132095A1	TUBE - 14 OZ.	
	AKCELA SSL SYNTHETIC GREASE	B505709	TUBE - 14 OZ.	
	AKCELA HTO ADDITIVE	B17508	1QT / .946L	
	AKCELA HTO PREMIX	298053A1	1G / 3.785L	
	AKCELA LIMITED SLIP ADDITIVE	B91246	16 OZ	
	AKCELA AXLE OIL ADDITIVE	402982A1	16 OZ	
Brake Oil	AKCELA CRAWLER BRAKE OIL	B91244	1QT / .946L	
Special Lubricants	AKCELA AG LUBRICANT	156576C91	1QT / .946L	
	AKCELA DURAFIT SPINDLE GREASE	B500418	35 LB. / 15.9L	
	AKCELA COTTON PICKER BAR LUBE	407515R1	35 LB. / 15.9L	
	AKCELA HI-SPEED SPINDLE CLEANER	B91241V	5G / 18.93L	

MINIMUM HARDWARE TIGHTENING TORQUES

IN NEWTON-METERS (FOOT POUNDS) FOR NORMAL ASSEMBLY APPLICATIONS

METRIC NON-FLANGED HARDWARE AND LOCKNUTS

NOMINAL SIZE	CLASS 5.8		CLASS 8.8		CLASS 10.9		LOCKNUT CL.8 W/CL8.8 BOLT
	UNPLATED	PLATED W/ZnCr	UNPLATED	PLATED W/ZnCr	UNPLATED	PLATED W/ZnCr	
M4	1.7 (15)*	2.2 (19)*	2.6 (23)*	3.4 (30)*	3.7 (33)*	4.8 (42)*	2.3 (20)*
M6	5.8 (51)*	7.6 (67)*	8.9 (79)*	12 (102)*	13 (115)*	17 (150)*	7.8 (69)*
M8	14 (124)*	18 (159)*	22 (195)*	28 (248)*	31 (274)*	40 (354)*	19 (169)*
M10	28 (21)	36 (27)	43 (32)	56 (41)	61 (45)	79 (58)	38 (28)
M12	49 (36)	63 (46)	75 (55)	97 (72)	107 (79)	138 (102)	66 (49)
M16	121 (89)	158 (117)	186 (137)	240 (177)	266 (196)	344 (254)	164 (121)
M20	237 (175)	307 (226)	375 (277)	485 (358)	519 (383)	671 (495)	330 (243)
M24	411 (303)	531 (392)	648 (478)	839 (619)	897 (662)	1160 (855)	572 (422)

NOTE: Torque values shown with * are inch pounds.

IDENTIFICATION HEX CAP SCREW AND CARRIAGE BOLTS CLASSES 5.6 AND UP

MANUFACTURER'S IDENTIFICATION

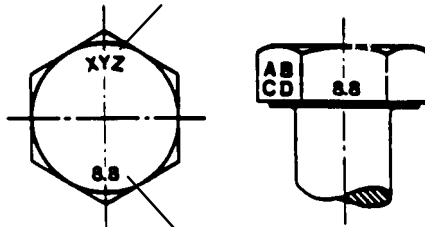

PROPERTY CLASS

HEX NUTS AND LOCKNUTS CLASSES 05 AND UP

MANUFACTURER'S IDENTIFICATION

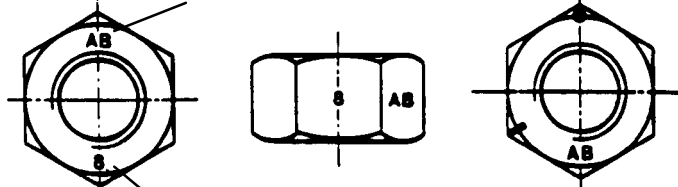

PROPERTY CLASS

CLOCK MARKING

MINIMUM HARDWARE TIGHTENING TORQUES

IN NEWTON-METERS (FOOT POUNDS) FOR NORMAL ASSEMBLY APPLICATIONS

INCH NON-FLANGED HARDWARE AND LOCKNUTS

NOMINAL SIZE	SAE GRADE 2		SAE GRADE 5		SAE GRADE 8		LOCKNUTS		NOMINAL SIZE
	UNPLATED or PLATED SILVER	PLATED W/ZnCr GOLD	UNPLATED or PLATED SILVER	PLATED W/ZnCr GOLD	UNPLATED or PLATED SILVER	PLATED W/ZnCr GOLD	GR.B w/GR5 BOLT	GR.C w/GR8 BOLT	
1/4	6.2 (55)*	8.1 (72)*	9.7 (86)*	13 (112)*	14 (121)*	18 (157)*	8.5 (75)*	12.2 (109)*	1/4
5/16	13 (115)*	17 (149)*	20 (178)*	26 (229)*	28 (250)*	37 (324)*	17.5 (155)*	25 (220)*	5/16
3/8	23 (17)	30 (22)	35 (26)	46 (34)	50 (37)	65 (48)	31 (23)	44 (33)	3/8
7/16	37 (27)	47 (35)	57 (42)	73 (54)	80 (59)	104 (77)	50 (37)	71 (53)	7/16
1/2	57 (42)	73 (54)	87 (64)	113 (83)	123 (91)	159 (117)	76 (56)	108 (80)	1/2
9/16	81 (60)	104 (77)	125 (92)	163 (120)	176 (130)	229 (169)	111 (82)	156 (115)	9/16
5/8	112 (83)	145 (107)	174 (128)	224 (165)	244 (180)	316 (233)	153 (113)	215 (159)	5/8
3/4	198 (146)	256 (189)	306 (226)	397 (293)	432 (319)	560 (413)	271 (200)	383 (282)	3/4
7/8	193 (142)	248 (183)	495 (365)	641 (473)	698 (515)	904 (667)	437 (323)	617 (455)	7/8
1	289 (213)	373 (275)	742 (547)	960 (708)	1048 (773)	1356 (1000)	654 (483)	924 (681)	1

NOTE: Torque values shown with * are inch pounds.

IDENTIFICATION CAP SCREWS AND CARRIAGE BOLTS



LOCKNUTS

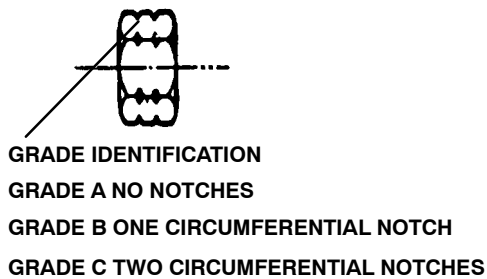

GRADE IDENTIFICATION
 GRADE A NO NOTCHES
 GRADE B ONE CIRCUMFERENTIAL NOTCH
 GRADE C TWO CIRCUMFERENTIAL NOTCHES

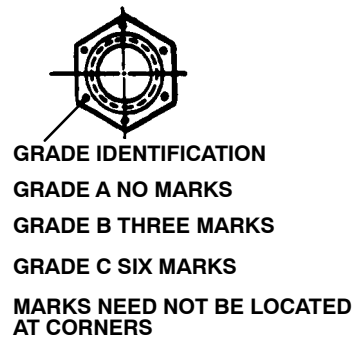

GRADE IDENTIFICATION
 GRADE A NO MARKS
 GRADE B THREE MARKS
 GRADE C SIX MARKS
 MARKS NEED NOT BE LOCATED AT CORNERS

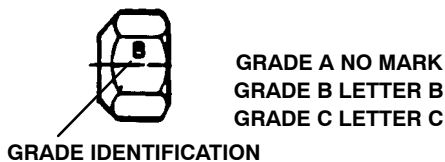

GRADE A NO MARK
 GRADE B LETTER B
 GRADE C LETTER C

INSTALLATION OF ADJUSTABLE FITTINGS IN STRAIGHT THREAD O-RING BOSSES

1. Lubricate the O-ring by coating it with a light oil or petroleum. Install the O-ring in the groove adjacent to the metal backup washer which is assembled at the extreme end of the groove, 4.
2. Install the fitting into the SAE straight thread boss until the metal backup washer contacts the face of the boss, 5.

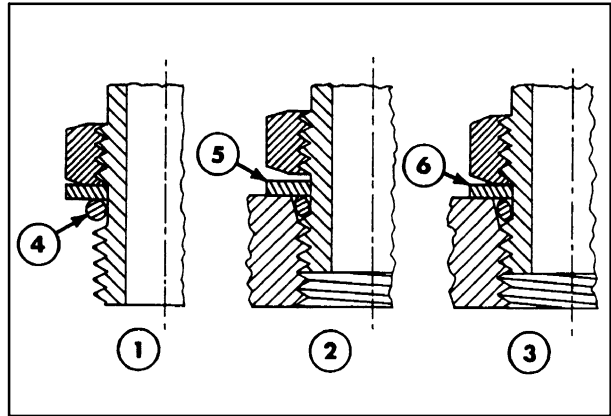

NOTE: Do not over tighten and distort the metal backup washer.

3. Position the fitting by turning out (counter-clockwise) up to a maximum of one turn. Holding the pad of the fitting with a wrench, tighten the locknut and washer against the face of the boss, 6.

STANDARD TORQUE DATA FOR HYDRAULIC TUBES AND FITTINGS

TUBE NUTS FOR 37° FLARED FITTINGS							O-RING BOSS PLUGS ADJUSTABLE FITTING LOCKNUTS, SWIVEL JIC - 37° SEATS				
TORQUE							TORQUE				
SIZE	TUBING OD		THREAD SIZE	POUND FOOT		NEWTON METERS		POUND FOOT		NEWTON METERS	
	In.	mm		Min.	Max.	Min.	Max.	Min.	Max.	Min.	Max.
4	1/4	6.4	7/16-20	9	12	12	16	6	10	8	14
5	5/16	7.9	1/2-20	12	15	16	20	10	15	14	20
6	3/8	9.5	9/16-18	21	24	29	33	15	20	20	27
8	1/2	12.7	3/4-18	35	40	47	54	25	30	34	41
10	5/8	15.9	7/8-14	53	53	72	79	35	40	47	54
12	3/4	19.1	1-1/16-12	77	82	104	111	60	70	81	95
14	7/8	22.2	1-3/16-12	90	100	122	136	70	80	95	109
16	1	25.4	1-5/16-12	110	120	149	163	80	90	108	122
20	1-1/4	31.8	1-5/8-12	140	150	190	204	95	115	129	158
24	1-1/2	38.1	1-7/8-12	160	175	217	237	120	140	163	190
32	2	50.8	2-1/2-12	225	240	305	325	250	300	339	407

These torques are not recommended for tubes of 1/2 inch (12.7 mm) OD and larger with wall thickness of 0.035 inch (0.889 mm) or less. The torque is specified for 0.035 inch (0.889 mm) wall tubes on each application individually.

Before installing and torquing 37° flared fittings, clean the face of the flare and threads with a clean

solvent or Loctite cleaner and apply hydraulic sealant Loctite™ no. 569 to the 37° flare and the threads.

Install fitting and torque to specified torque, loosen fitting and retorque to specifications.



Suggest:

For more complete manuals. Please go to the home page.

<https://www.ebooklibonline.com>

If the above button click is invalid. Please download this document first, and then click the above link to download the complete manual.

Thank you so much for reading

PIPE THREAD FITTING TORQUE

Before installing and tightening pipe fittings, clean the threads with a clean solvent or Loctite cleaner and apply sealant Loctite no. 567 for all fittings including stainless steel or no. 565 for most metal fittings. For high filtration/zero contamination systems use no. 545.

Thread Size	Torque (Maximum)
1/8 inch - 27	13 N·m (10 lb ft)
1/4 inch - 18	16 N·m (12 lb ft)
3/8 inch - 14	22 N·m (16 lb ft)
1/2 inch - 14	41 N·m (30 lb ft)
3/4 inch - 14	54 N·m (40 lb ft)

INSTALLATION OF ORFS (O-RING FLAT FACED) FITTINGS

When installing ORFS fittings thoroughly clean both flat surfaces of the fittings, 1, and lubricate the O-ring, 2, with light oil. Make sure both surfaces are aligned properly. Torque the fitting to specified torque listed throughout the service manual.

IMPORTANT: If the fitting surfaces are not properly cleaned, the O-ring will not seal properly. If the fitting surfaces are not properly aligned, the fittings may be damaged and will not seal properly.

IMPORTANT: Always use genuine Case IH replacement oils and filters to ensure proper lubrication and filtration of engine and hydraulic system oils.

The use of proper oils, grease, and keeping the hydraulic system clean will extend machine and component life.

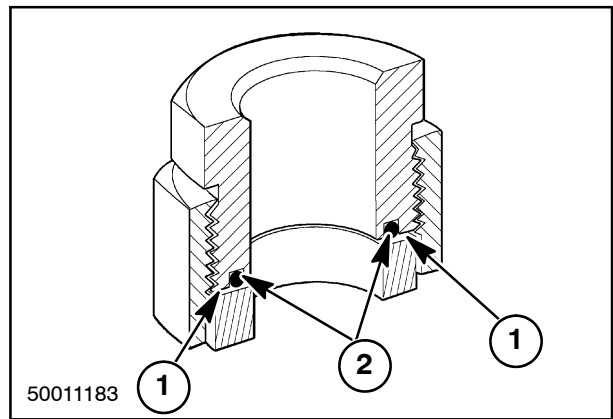

SECTION 31 - IMPLEMENT POWER TAKE OFF (PTO)

Chapter 1 - Drive Lines (Standard Tongue)

CONTENTS

Section	Description	Page
	DC132 Standard Tongue	2
	Introduction	2
	Auto-Lok Slide Lock	3
	Disassembly	3
	Assembly	5
	Drive Shaft Removal and Installation	6
	Standard Driveline Guards - Disassembly	9
	Primary Driveline Guards - Disassembly	10
	Driveline Guards - Inspection	11
	Secondary Driveline Guards - Assembly	11
	80° CV Front Guard Assembly	12
	CV/U-Joints	13
	Disassembly	13
	Inspection	14
	Assembly	15
	Tongue Jackshaft	16
	Disassembly	16
	Assembly	18

<https://www.ebooklibonline.com>

Hello dear friend!

Thank you very much for reading.

Enter the link into your browser.

The full manual is available for immediate download.

<https://www.ebooklibonline.com>