

**Chassis
3388, 3588, 3788, 6388,
6588 & 6788 Tractors**

Service Manual

GSS-1490-2

Reprinted

CASE III

General Contents

Safe Work Rules	IV
Standard Torque Data for Nuts and Bolts	VI
Metric Conversion Tables	VIII
Standard Torque Data for Hydraulic Tubes and Fittings	X
Flangette Bearing Installation	XII
Special Service Tools Required	XIII
Service Information System (S.I.S.)	XVIII

1	A/C AND TRACTOR SPLITS
2	FRONT AXLE ASSEMBLY
3	STEERING
4	ENGINE
5	FUEL SYSTEM AND HOODS
6	ELECTRICAL SYSTEM
7	COOLING SYSTEM
8	CLUTCH AND FLYWHEEL
9	TRANSMISSION AND TRANSFER CASE
10	REAR DIFFERENTIAL
11	REAR AXLE, HOUSING AND WHEELS
12	BRAKES
13	INDEPENDENT POWER TAKE OFF
14	HYDRAULIC SYSTEM
15	TESTING HYDRAULIC SYSTEM

WORK SAFELY – FOLLOW THESE RULES



This symbol is used to call your attention to instructions concerning your personal safety. Be sure to observe and follow these instructions.

1. To prevent injury, do not allow children or by-standers around the machine while it is being adjusted and/or serviced.

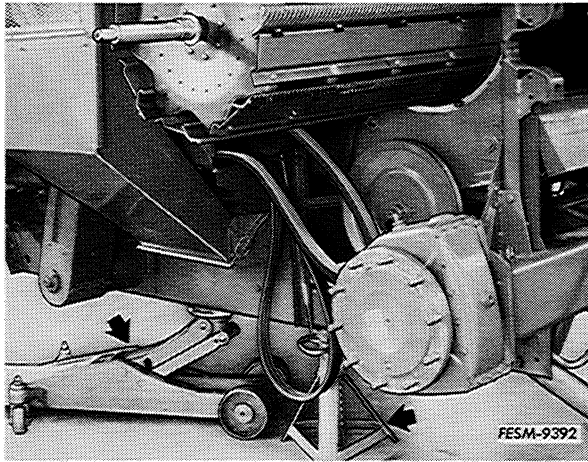

2. Always use safety stands in conjunction with hydraulic jacks or hoists. Do not rely on the jack or hoist to carry the load, they could fail.

3. Articulated Tractors – Always use the frame lock pin when servicing the tractor in the area of the hinged or pivot point of the frame. The lock pin must be in place when making adjustments with the engine running. The lock pin prevents accidental pivoting of the frame. Always remove the lock pin and store correctly before attempting to steer the tractor.

4. Always wear safety glasses when using a hammer, chisel or other tools that may cause chips to fly.

5. Keep work area organized and clean. Wipe up oil or spills of any kind. Keep tools and parts off of the floor. Eliminate the possibility of a fall which could result in a serious injury.

6. Be sure to reinstall safety devices, guards or shields after adjusting and/or servicing the machine.

7. After servicing, be sure all tools, parts, or servicing equipment are removed from the machine.

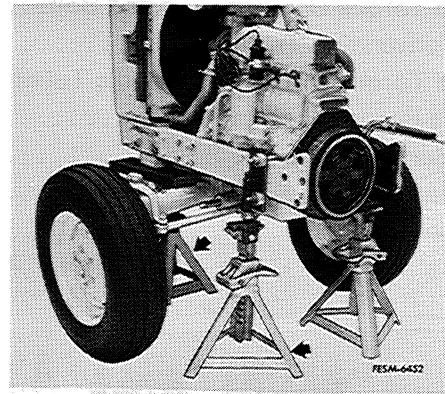

8. When splitting tractors, or disassembling machines, be sure to use safety stands and adequate supports to prevent tipping or rollover.

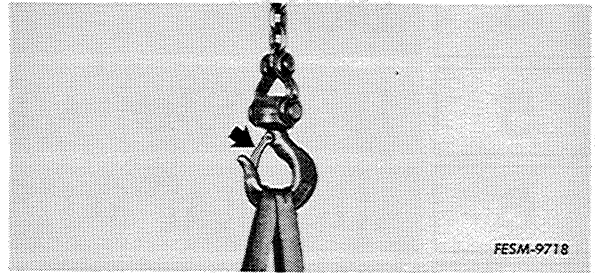

9. Use a safety catch on all hoist hooks. Do not take a chance, the load could slip off of the hook.



10. When using an acetylene torch always wear welding goggles and gloves. Keep a "charged" fire extinguisher within reach. Be sure the acetylene and oxygen tanks are separated by a metal shield and are chained to the cart. Do not weld or heat areas near fuel tanks or fuel lines and utilize proper shielding around hydraulic lines.

<https://www.ebooklibonline.com>

Hello dear friend!

Thank you very much for reading.

Enter the link into your browser.

The full manual is available for immediate download.

<https://www.ebooklibonline.com>

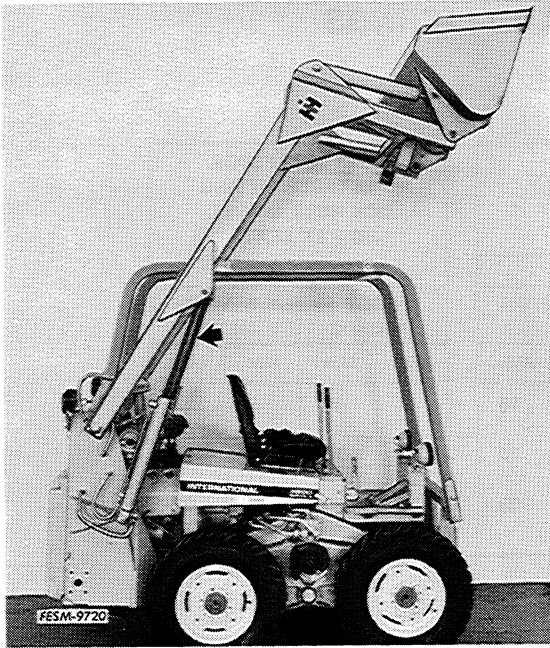

11. Always use a safety bar to block hydraulic cylinders. Never rely on the machine hydraulic system to hold when working on loaders, etc. A hydraulic line or cylinder could fail or someone could accidentally strike the control levers causing the loader to fall.

12. Electrical storage batteries give off highly inflammable hydrogen gas when charging and continue to do so for some time after receiving a steady charge. Do not under any circumstances allow an electric spark or an open flame near the battery. Always disconnect a battery cable before working on the electrical system.

13. Hydraulic fluid escaping under pressure can have enough force to penetrate the skin. Hydraulic fluid may also infect a minor cut or opening in the skin. If injured by escaping fluid, see a doctor at once. Serious infection or reaction can result if medical treatment is not given immediately.

Do not attempt to repair or tighten hoses that are under pressure, when the boom is raised, or with the tractor engine running. Cycle all hydraulic control valves to relieve all pressure before disconnecting the lines or performing other work on the hydraulic system. Make sure all connections are tight and hoses and lines are in good condition before applying pressure to the system. To locate a leak under pressure, use a small piece of cardboard or wood. Never use hands.

14. Handle gasoline with care - it is highly flammable:

- (a) Use approved gasoline container.
- (b) Never remove the fuel tank cap or fill the fuel tank when the engine is running, is hot, or indoors. Also, do not smoke when working around flammable fuel.
- (c) When refueling, keep the hose and nozzle of the funnel and container in contact with the metal of the fuel tank to avoid the possibility of an electric spark igniting the fuel. Do not overfill the fuel tank - overflow creates fire hazard. Wipe up spilled gasoline.
- (d) Replace fuel tank cap securely.

15. Always use a protective fixture when inflating tubeless tires that have been repaired or are loose on the rim. Do not inflate over 30 psi to seat the tire bead.

16. Use pullers to remove bearings, bushings, gears, cylinder sleeves, etc. when applicable. Use hammers, punches and chisels only when absolutely necessary. Then, be sure to wear safety glasses.

17. Be careful when using compressed air to dry parts. Use approved air blow guns, do not exceed 30 psi, wear safety glasses or goggles and use proper shielding to protect everyone in the work area.

18. Do not wear rings, wrist watches or loose fitting clothing when working on machinery, they could catch on moving parts causing serious injury. Wear sturdy, rough-soled work shoes. Never adjust and/or service a machine in bare feet, sandals or sneakers.

19. Excessive or repeated skin contact with sealants or solvents may cause skin irritation. In case of skin contact, remove sealant or solvent promptly by washing with soap and water.

IMPORTANT: The above is only a partial list of safe work rules. In addition, always refer to the Operator's Manual for the specific machine for additional safe work rules regarding the machine operation.

STANDARD TORQUE DATA FOR HYDRAULIC TUBES AND FITTINGS

TUBE NUTS FOR 37° FLARED FITTINGS				O-RING BOSS PLUGS, ADJUSTABLE FITTING LOCK NUTS, SWIVEL JIC - 37° SEATS							
SIZE	TUBING O.D.		THREAD SIZE	TORQUE				TORQUE			
	Inches	mm		FOOT POUNDS		NEWTON METERS		FOOT POUNDS		NEWTON METERS	
				Min.	Max.	Min.	Max.	Min.	Max.	Min.	Max.
4	1/4	6.4	7/16-20	9	12	12	16	6	10	8	14
5	5/16	7.9	1/2-20	12	15	16	20	10	15	14	20
6	3/8	9.5	9/16-18	21	24	29	33	15	20	20	27
8	1/2	12.7	3/4-16	35	40	47	54	25	30	34	41
10	5/8	15.9	7/8-14	53	58	72	79	35	40	47	54
12	3/4	19.1	1-1/16-12	77	82	104	111	60	70	81	95
14	7/8	22.2	1-3/16-12	90	100	122	136	70	80	95	109
16	1	25.4	1-5/16-12	110	120	149	163	80	90	108	122
20	1-1/4	31.8	1-5/8-12	140	150	190	204	95	115	129	156
24	1-1/2	38.1	1-7/8-12	160	175	217	237	120	140	163	190
32	2	50.8	2-1/2-12	225	240	306	325	250	300	339	407

Above torque figures are recommended for plain, cadmium or zinc plated fittings, dry or wet installations.

Swivel nuts either swaged or brazed.

These torques are not recommended for tubes of 1/2" (12.7 mm) O.D. and larger with wall thickness of .035" (.889 mm) or less. The torque is specified for .035" (.889 mm) wall tubes on each application individually.

INSTRUCTIONS FOR THE ADJUSTABLE STANDARD THREAD TUBE FITTINGS

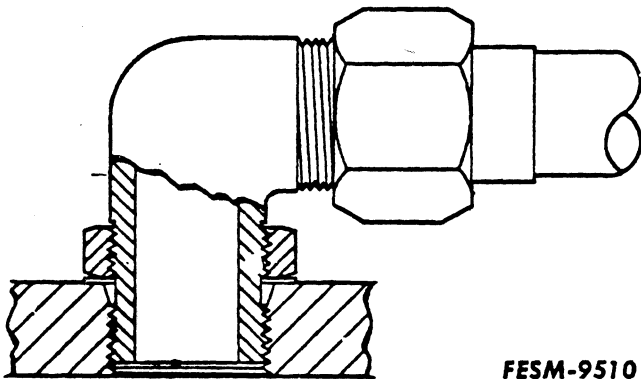

FESM-9510

The following general instructions will apply to the adjustable straight threaded hydraulic O-ring boss tube fitting of the 37° style shown.

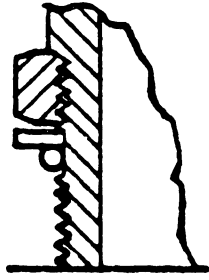

FESM-9511

1. Lubricate the O-ring seal with a light coat of oil or petroleum jelly and install it into the groove of the fitting next to the metal back-up washer.

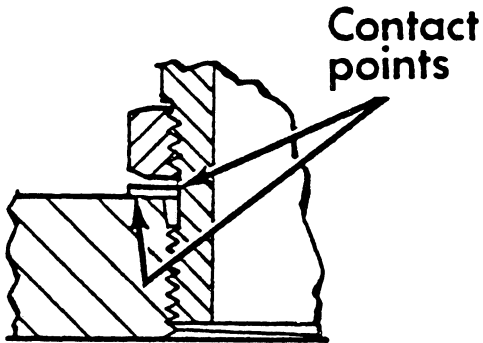

FESM-9512

2. Install the fitting until the metal back-up washer contacts the face of the boss. This locates the maximum depth of the fitting.

NOTE: Do not overtighten and distort the metal back-up washer.

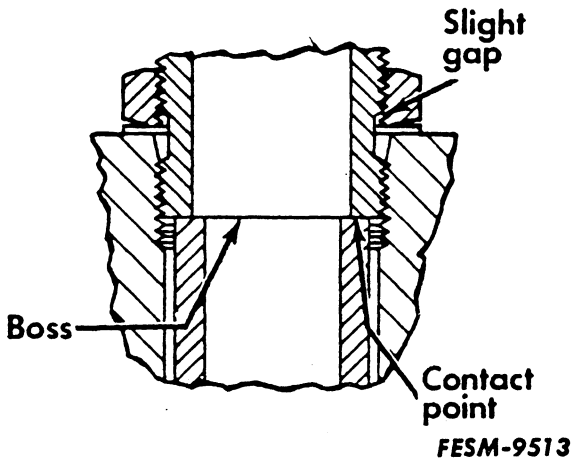

FESM-9513

3. Position the fitting by turning it out (counterclockwise) to a maximum of one complete turn and tighten the locknut to the recommended torque.

NOTE: In special applications where this fitting is used, the fitting will contact the internal part of the straight threaded boss prior to the back-up washer.

CONVERSION TABLE

—inches to millimeters—

Inches	Millimeters	Inches	Millimeters	Inches	Millimeters	Inches	Millimeters
1	25.4	26	660.4	51	1295.4	76	1930.4
2	50.8	27	685.8	52	1320.8	77	1955.8
3	76.2	28	711.2	53	1346.2	78	1981.2
4	101.6	29	736.6	54	1371.6	79	2006.6
5	127.0	30	762.0	55	1397.0	80	2032.0
6	152.4	31	787.4	56	1422.4	81	2057.4
7	177.8	32	812.8	57	1447.8	82	2082.8
8	203.2	33	838.2	58	1473.2	83	2108.2
9	228.6	34	863.6	59	1498.6	84	2133.6
10	254.0	35	889.0	60	1524.0	85	2159.0
11	279.4	36	914.4	61	1549.4	86	2184.4
12	304.8	37	939.8	62	1574.8	87	2209.8
13	330.2	38	965.2	63	1600.2	88	2235.2
14	355.6	39	990.6	64	1625.6	89	2260.6
15	381.0	40	1016.0	65	1651.0	90	2286.0
16	406.4	41	1041.4	66	1676.4	91	2311.4
17	431.8	42	1066.8	67	1701.8	92	2336.8
18	457.2	43	1092.2	68	1727.2	93	2362.2
19	482.6	44	1117.6	69	1752.6	94	2387.6
20	508.0	45	1143.0	70	1778.0	95	2413.0
21	533.4	46	1168.4	71	1803.4	96	2438.4
22	558.8	47	1193.8	72	1828.8	97	2463.8
23	584.2	48	1219.2	73	1854.2	98	2489.2
24	609.6	49	1244.6	74	1879.6	99	2514.6
25	635.0	50	1270.0	75	1905.0	100	2540.0

1 inch = 25.4 millimeters

To convert inches to millimeters, the inch value to be converted should be written down, carried to as many decimal places as the desired accuracy requires. It should then be split into groups of not more than two figures each. The equivalent of each group should then be taken from the table, proper regard being given to the position of the decimal point in each case, and the equivalent of the inch value given.

For example, to convert 2.4635 inches to millimeters:

2.0000 inches = 50.80000 millimeters
 .4600 inches = 11.68400
 .0035 inches = .08890
 2.4635 inches = 62.57290 millimeters
 Correct to 3 decimal places.
 2.4635 inches = 62.573 millimeters

CONVERSION TABLE

—millimeters to inches—

Millimeters	Inches	Millimeters	Inches	Millimeters	Inches	Millimeters	Inches
1	0.03937008	26	1.0236220	51	2.0078740	76	2.9921260
2	0.07874016	27	1.0629921	52	2.0472441	77	3.0314961
3	.11811024	28	1.1023622	53	2.0866142	78	3.0708661
4	.15748031	29	1.1417323	54	2.1259842	79	3.1102362
5	.19685039	30	1.1811024	55	2.1653543	80	3.1496063
6	.23622047	31	1.2204724	56	2.2047244	81	3.1889764
7	.27559055	32	1.2598425	57	2.2440945	82	3.2283465
8	.31496063	33	1.2992126	58	2.2834646	83	3.2677165
9	.35433071	34	1.3385827	59	2.3228346	84	3.3070866
10	.3937008	35	1.3779528	60	2.3622047	85	3.3464567
11	.4330709	36	1.4173228	61	2.4015748	86	3.3858268
12	.4724409	37	1.4566929	62	2.4409449	87	3.4251968
13	.5118110	38	1.4960630	63	2.4803150	88	3.4645669
14	.5511811	39	1.5354331	64	2.5196850	89	3.5039370
15	.5905512	40	1.5748031	65	2.5590551	90	3.5433071
16	.6299213	41	1.6141732	66	2.5984252	91	3.5826772
17	.6692913	42	1.6535433	67	2.6377953	92	3.6220472
18	.7086614	43	1.6929134	68	2.6771654	93	3.6614173
19	.7480315	44	1.7322835	69	2.7165354	94	3.7007874
20	.7874016	45	1.7716535	70	2.7559055	95	3.7401575
21	.8267717	46	1.8110236	71	2.7952756	96	3.7795276
22	.8661417	47	1.8503937	72	2.8346457	97	3.8188976
23	.9055118	48	1.8897638	73	2.8740157	98	3.8582677
24	.9448819	49	1.9291339	74	2.9133858	99	3.8976378
25	.9842520	50	1.9685039	75	2.9527559	100	3.937008

1 mm = .03937008 inches

To convert millimeters to inches the millimeter value to be converted should be written down, carried to as many decimal places as the desired accuracy requires. It should then be split up into groups of not more than two figures each. The equivalent of each group should then be taken from the table, proper regard being given to the position of the decimal point in each case, and the equivalent of the several groups found by addition. This sum will be the inch equivalent of the millimeter value given.

— For example to convert 75.384 millimeters to inches:

75.000 millimeters = 2.9527559 inches

.380 millimeters = .0149606

.004 millimeters = .0001574

75.384 millimeters = 2.9678739 inches

Correct to 5 decimal places.

75.384 millimeters = 2.96787 inches



Suggest:

For more complete manuals. Please go to the home page.

<https://www.ebooklibonline.com>

If the above button click is invalid. Please download this document first, and then click the above link to download the complete manual.

Thank you so much for reading

STANDARD TORQUE DATA FOR INCH NUTS AND BOLTS— FOOT POUNDS

Recommended torque for all Standard Unplated Nuts and Bolts, provided:

- A. Surface finish is oxide coated, oil quenched or bright.
- B. All thread surfaces are clean and lubricated with SAE-30 engine oil or equivalent (See NOTE.)
- C. Joints are rigid, that is, no gaskets or compressible materials are used.
- D. When reusing nuts or bolts use minimum torque values.







NOTE: Multiply the standard torque by:
 .65 when finished jam nuts are used.
 .70 when Molykote, white lead or similar mixtures are used as lubricants.
 .75 when phosphate coated and oiled bolts or nuts are used.
 .85 when cadmium or zinc dichromate bolts or nuts are used.
 .90 when hardened surfaces are used under the nut or bolt head (this applies to standard unplated hardware only).

1 FOOT POUND = 1.355 NEWTON METERS

Bolt or Stud Diameter	Type 1 Studs Only		Type 1 Bolts 6" length or less		Type 1 Bolts longer than 6"		Type 5 (all lengths)		Type 8 (all lengths)			
	Min.	Max.	Min.	Max.	Min.	Max.	Min.	Max.	Only when used† in cast (gray) iron		All other applications	
Inches									Min.	Max.	Min.	Max.
1/4	5	6	5	6	3	3	9	10	11	13	12	14
5/16	12	13	12	13	6	7	19	21	24	27	27	30
3/8	21	24	21	24	11	13	33	37	43	47	45	50
7/16	35	38	35	38	19	21	53	60	69	76	75	85
1/2	52	58	52	58	29	32	80	90	104	117	115	130
9/16	70	80	70	80	41	46	115	130	150	170	165	185
5/8	98	110	98	110	57	63	160	180	210	230	220	250
3/4	174	195	174	195	100	112	290	320	350	390	400	450
7/8	300	330	162	181	162	181	420	470	570	630	650	730
1	420	470	250	270	250	270	630	710	850	950	970	1090
1-1/8	600	660	350	380	350	380	850	950	1200	1350	1380	1550
1-1/4	840	940	490	540	490	540	1200	1350	1700	1900	1940	2180
1-3/8	1100	1230	640	710	640	710	1570	1760	2300	2500	2600	2800
1-1/2	1470	1640	850	940	850	940	2000	2300	3000	3300	3300	3700
1-3/4	2350	2450	1330	1490	1330	1490	3300	3700	4700	5200	5300	6000
2	3500	3900	2000	2200	2000	2200	5000	5500	7000	7800	8000	9000

†When bolt penetration is 1-1/2 times the diameter of the bolt.

BOLT TYPE IDENTIFICATION CHART

IH TYPE	S.A.E. GRADE	DESCRIPTION	BOLT HEAD MARKING *
1	1 Equivalent or 2	WILL HAVE A  STANDARD MONOGRAM IN THE CENTER OF THE HEAD Low or Medium Carbon Steel Not Heat Treated	
5	5	WILL HAVE A  AND 3 RADIAL LINES Quenched and Tempered Medium Carbon Steel	
8	8	WILL HAVE A  AND 6 RADIAL LINES Quenched and Tempered Special Carbon or Alloy Steel	

*The center marking identifies the bolt manufacturer. The  monogram is currently used. Some bolts may still have an IH or a raised dot which previously identified IH bolts.

STANDARD TORQUE DATA FOR INCH NUTS AND BOLTS— NEWTON METERS

Recommended torque for all Standard Unplated Nuts and Bolts, provided:

- A. Surface finish is oxide coated, oil quenched or bright.
- B. All thread surfaces are clean and lubricated with SAE-30 engine oil or equivalent (See NOTE.)
- C. Joints are rigid, that is, no gaskets or compressible materials are used.
- D. When reusing nuts or bolts use minimum torque values.







NOTE: Multiply the standard torque by:
 .65 when finished jam nuts are used.
 .70 when Molykote, white lead or similar mixtures are used as lubricants.
 .75 when phosphate coated and oiled bolts or nuts are used.
 .85 when cadmium or zinc dichromate bolts or nuts are used.
 .90 when hardened surfaces are used under the nut or bolt head (this applies to standard unplated hardware only).

1 NEWTON METER = 0.738 FOOT POUND

Bolt or Stud Diameter	Type 1 Studs Only		Type 1 Bolts 6" length or less		Type 1 Bolts longer than 6"		Type 5 (all lengths)		Type 8 (all lengths)			
	Inches	Min.	Max.	Min.	Max.	Min.	Max.	Min.	Max.	Only when used† in cast (gray) iron		All other applications
1/4	7	8	7	8	4	4	12	14	15	18	16	19
5/16	17	18	17	18	8	10	26	29	33	37	37	41
3/8	29	33	29	33	15	18	45	50	58	64	61	68
7/16	48	52	48	52	26	29	72	81	94	103	102	115
1/2	71	79	71	79	39	43	108	122	141	159	156	176
9/16	95	108	95	108	56	62	156	176	205	230	225	250
5/8	133	149	133	133	77	85	220	245	285	310	300	340
3/4	240	265	240	265	136	152	390	430	470	530	540	610
7/8	400	450	220	245	220	245	570	640	770	850	880	990
1	570	640	340	365	340	365	850	960	1150	1290	1300	1480
1-1/8	810	900	470	510	470	510	1150	1290	1630	1830	1870	2100
1-1/4	1140	1270	660	730	660	730	1600	1830	2300	2600	2600	3000
1-3/8	1490	1670	870	960	870	960	2100	2400	3100	3400	3500	3800
1-1/2	2000	2200	1150	1270	1150	1270	2700	3100	4100	4500	4500	5000
1-3/4	3200	3300	1800	2000	1800	2000	4500	5000	6400	7000	7100	8100
2	4750	5300	2700	3000	2700	3000	6800	7500	9500	10500	10800	12200

†When bolt penetration is 1-1/2 times the diameter of the bolt.

BOLT TYPE IDENTIFICATION CHART

IH TYPE	S.A.E. GRADE	DESCRIPTION	BOLT HEAD MARKING *
1	Equivalent 1 or 2	WILL HAVE A  STANDARD MONOGRAM IN THE CENTER OF THE HEAD Low or Medium Carbon Steel Not Heat Treated	
5	5	WILL HAVE A  AND 3 RADIAL LINES Quenched and Tempered Medium Carbon Steel	
8	8	WILL HAVE A  AND 6 RADIAL LINES Quenched and Tempered Special Carbon or Alloy Steel	

*The center marking identifies the bolt manufacturer. The  monogram is currently used. Some bolts may still have an IH or a raised dot which previously identified IH bolts.

<https://www.ebooklibonline.com>

Hello dear friend!

Thank you very much for reading.

Enter the link into your browser.

The full manual is available for immediate download.

<https://www.ebooklibonline.com>