

**220
Baler**

Service Manual

9-64161

Reprinted

CASE

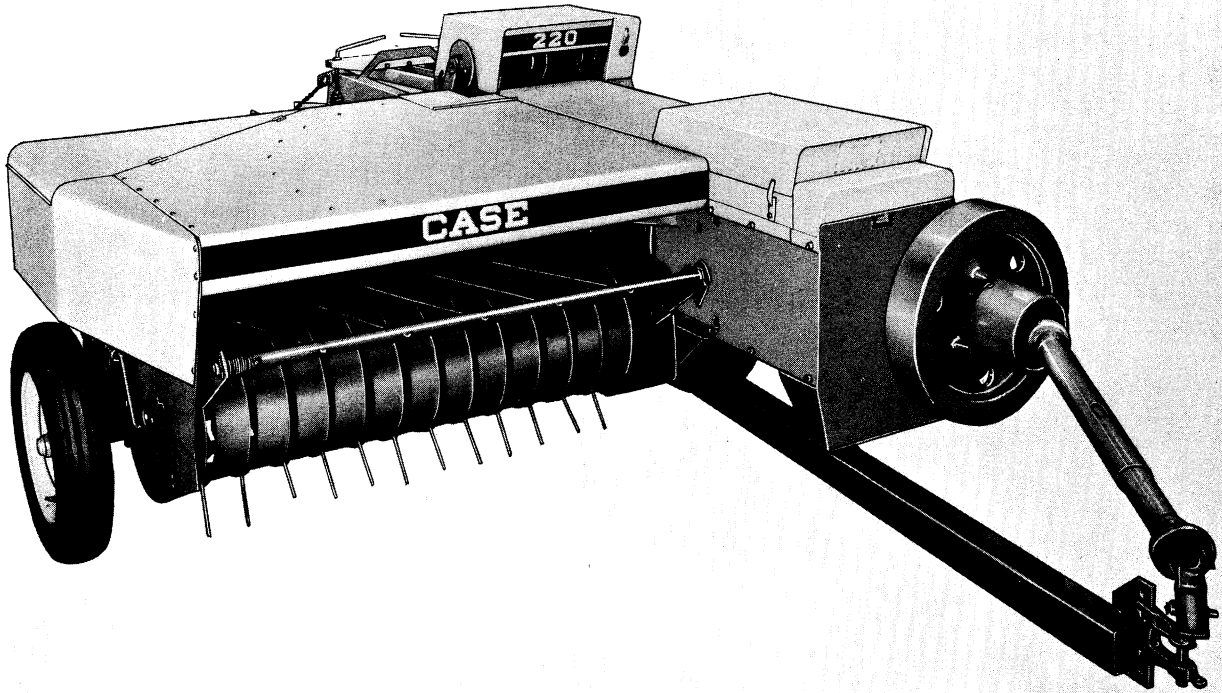

Figure 1. Model 220 Baler--with PTO Drive

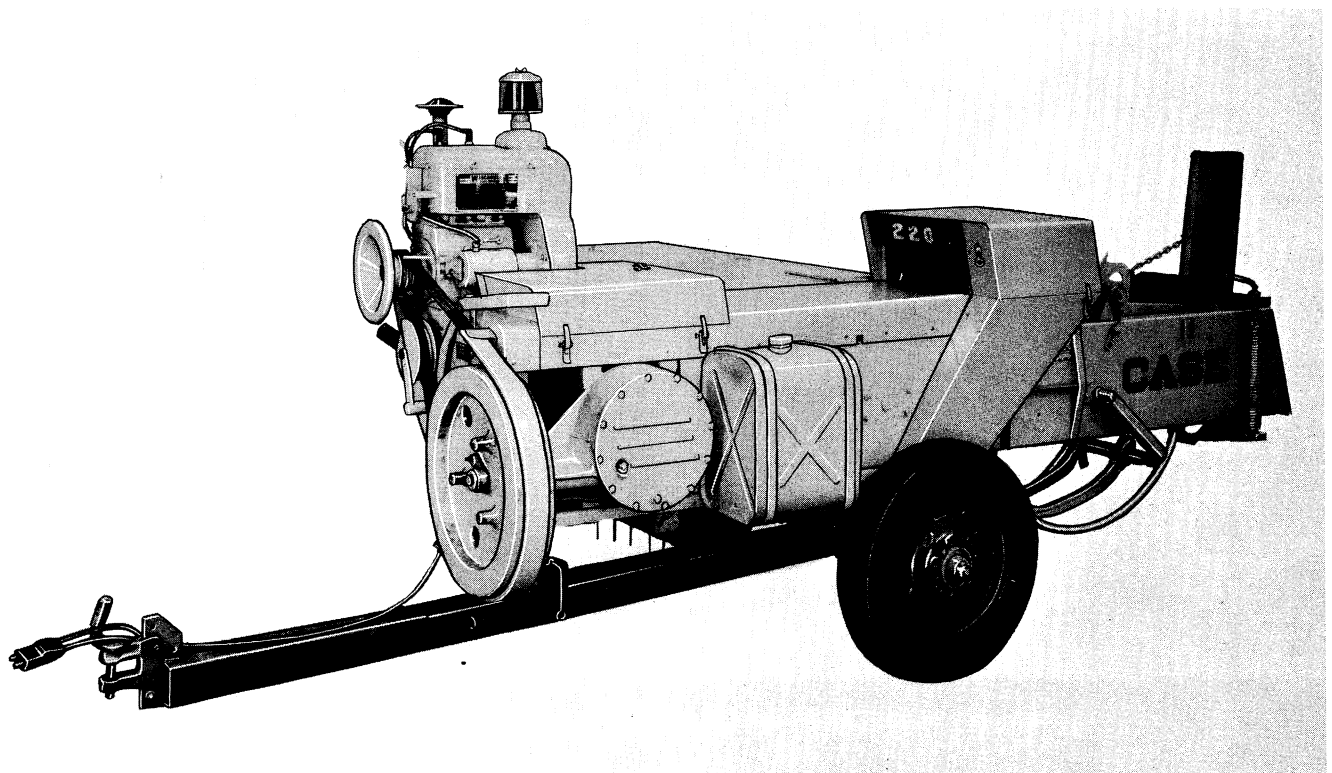

Figure 2. Model 220 Baler--with Engine Drive

INTRODUCTION

The intentions of this Service Manual is to provide you with the basic knowledge necessary for proper Set-Up, Pre-Delivery and Service of the Model 220 Baler. As an Authorized CASE Dealer, your staff must be qualified to render these basic functions.

Instruct the personnel of your organization to read and discuss this manual thoroughly -- it is to your advantage.

SERIAL NUMBERS

To receive prompt service and reduce chances for misunderstanding, always obtain the model and serial number of units requiring replacement parts.

The Serial Number for the Model 220 Baler is located at the front of the bale case. See Figure 3.

The Serial Number for the Wisconsin Model THD Engine is stamped on the number plate. See Figure 4.

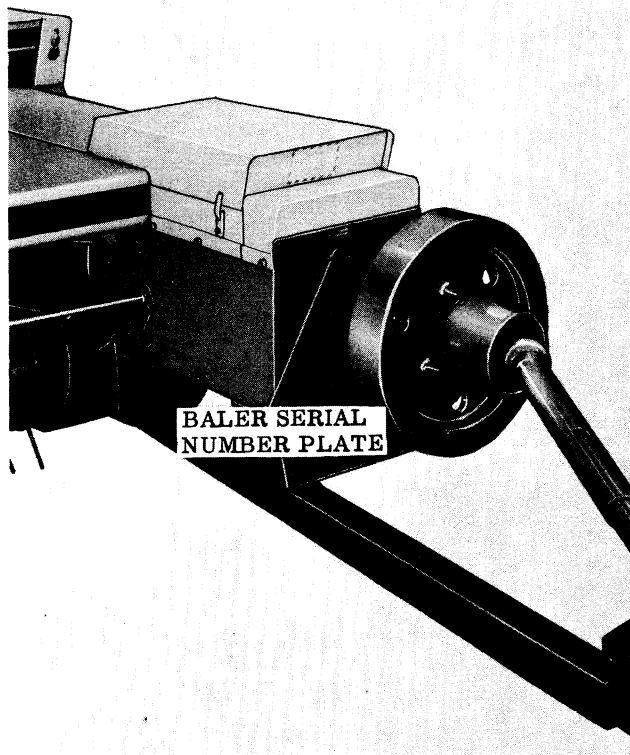

Figure 3. Baler Serial Number

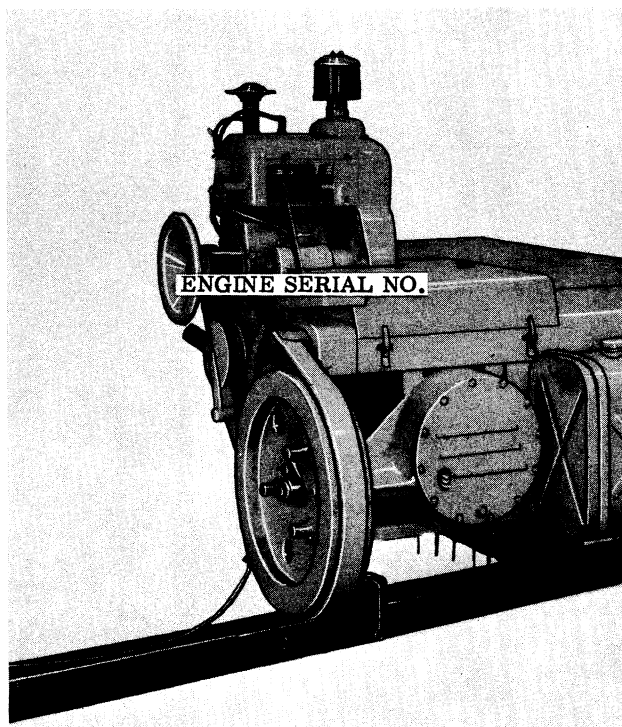

Figure 4. Engine Serial Number

<https://www.ebooklibonline.com>

Hello dear friend!

Thank you very much for reading.

Enter the link into your browser.

The full manual is available for immediate download.

<https://www.ebooklibonline.com>

GENERAL SPECIFICATIONS

DRIVE OPTION

POWER TAKE-OFF

Clutch	Built-in Overrunning
Safety Slip Clutch	Spring Loaded Disc
Operating Speed	540 RPM (Under Load)

ENGINE

Make	Wisconsin THD
Type	4 Cycle, Air-Cooled
No. of Cylinders	2
Spark Plug Size	18 MM

Governed Engine Speed

No Load	2950 RPM
Full Load	2800 RPM

Bore and Stroke

Air-Cleaner	3-1/4 x 3-1/4 Inches
	Oil Bath-With-Dry
	Type Pre-Filter

Engine Crankcase (Capacity)

3-1/2 Quarts

Fuel Tank (Capacity)

9-1/4 Gallons

Standard Equipment

Rotating Air Intake Screen
High Temperature Safety Switch
Electric Starter

BALER

DRAWBAR

Type	Swinging
2-Positions	Operating and Transport

PICKUP

Type	Drum
Pickup Fingers	24 Individually Mounted
Height Control	Manually Adjusted
Mounting	Floating Type Spring Mounted

Drive

Power Driven-with Overrunning
Shear Bolt Safety Clutch

Effective Operating Width

56 Inches

BALER (CONT'D)

FEEDING MECHANISM

Type

One Feeder Arm
-With Sweep Fork Fingers

Size of Feed Opening

12 x 21 Inches

Area of Feed Opening

252 Square Inches

PLUNGER

Type

Slotted, Box Design

Speed

65 Strokes Per Minute

Length of Stroke

26 Inches

KNOTTER

Type

Dual CASE Design

Drive

Roller Chain Drive

BALE DIMENSIONS

Perimeter Size

14 x 18 Inches

Adjustable Length

12 to 52 Inches

WHEELS

Bearings

Tapered Roller

TIRES

Size

Right Hand Tire

5.00 x 15 (2 ply)

Left Hand Tire

6.40 x 15 (6 ply)

Air Pressure

Right Hand Tire

20 Pounds

Left Hand Tire

40 Pounds

WEIGHT (Approximate)

Power Take-Off Baler

1850 Pounds

Engine Baler

2100 Pounds

BALER MEASUREMENTS (APPROXIMATE)

LENGTH

Bale Diverter extended

16 Feet, 1 Inch

Bale Diverter folded

13 Feet, 5 Inches

WIDTH

7 Feet, 10 Inches

HEIGHT

Engine Drive Baler

69 Inches

PTO Drive Baler

50 Inches

Ground-to-Feeder Deck

41 Inches

Ground-to-Bale Case

21 Inches

SAFETY INSTRUCTIONS

As a CASE Dealer you and your personnel are urged to use every possible means toward the elimination of preventable accidents in your Dealership and to conduct a direct program of Safety Education and Training for Customers operating farm machinery.

**READ
SAFETY
PRECAUTIONS
CAREFULLY**

1. Provide an adequate, clean, well-lighted location for setting up and servicing machinery.
2. Use only those tools that are in perfect condition and are the right tools for the job.
3. Stress the importance of first aid training and fire prevention measures to all personnel.
4. Make certain all personnel know the location of the first aid kit and all fire extinguishers.
5. Before delivering a machine to a customer, inspect it thoroughly to make sure all bolts, supports, braces, wheels, tires, belts, hoses, chains and springs are in place and tightened properly.
6. Check each machine before delivery to make certain it is equipped with all the standard safety devices provided.
7. Don't attempt to remove hay from the Launcher while it is operating.
8. Provide customer with a list pointing out and describing all of the special safety devices available for his machine.
9. When delivering machine to the customer,
 - A. Point out every safety device. Explain and demonstrate its function if necessary.
 - B. Point out every warning decal and explain its purpose.
 - C. Locate and point out to the customer all safety information and precautions included in the Operator's Instruction Manual.
 - D. Point out every known operating procedure that must be observed for safety reasons.
10. Follow up on your customers' safety education at every available opportunity.



Suggest:

For more complete manuals. Please go to the home page.

<https://www.ebooklibonline.com>

If the above button click is invalid. Please download this document first, and then click the above link to download the complete manual.

Thank you so much for reading

SETTING UP INSTRUCTIONS

WHEEL INSTALLATION

Install both the right and left wheels according to the instructions listed below. Any installation variations will be pointed out.

1. Tip the Baler from its vertical shipping position onto solid blocking. Jack up the Baler to the proper height for wheel installation.
2. Loosen the lock bolt and jam nut in the axle housing. See Figure 5.
3. Slide the spindle into the axle. Align the hole in the axle block. See Figure 5.
 - a. On the right side slide the spindle into the bottom hole if a 5:00 x 15 implement tire is installed.

Slide the spindle into the top hole if a 6:40 - 6:70 x 15 automotive type tire is installed.

- a. On the right side use a 1/2 x 2-1/2" N.F. hex. bolt, lockwasher and nut.
 - b. On the left side use a 1/2 x 2-3/4" N.F. hex. bolt, lockwasher and nut.
4. Insert the hex. bolt into the access hole and secure with lockwasher and nut.
 - a. On the right side use a 1/2 x 2-1/2" N.F. hex. bolt, lockwasher and nut.
 - b. On the left side use a 1/2 x 2-3/4" N.F. hex. bolt, lockwasher and nut.
 5. Retighten the lock bolt and jam nut.
 6. Check both tires for proper tire pressure. Inflate or deflate to meet the following specifications:

Right Hand Tire	20 PSI
Left Hand Tire	40 PSI

Check the valve stem caps for proper installation.

7. Remove the two shipping blocks from the side of the bale case. See Figure 5.

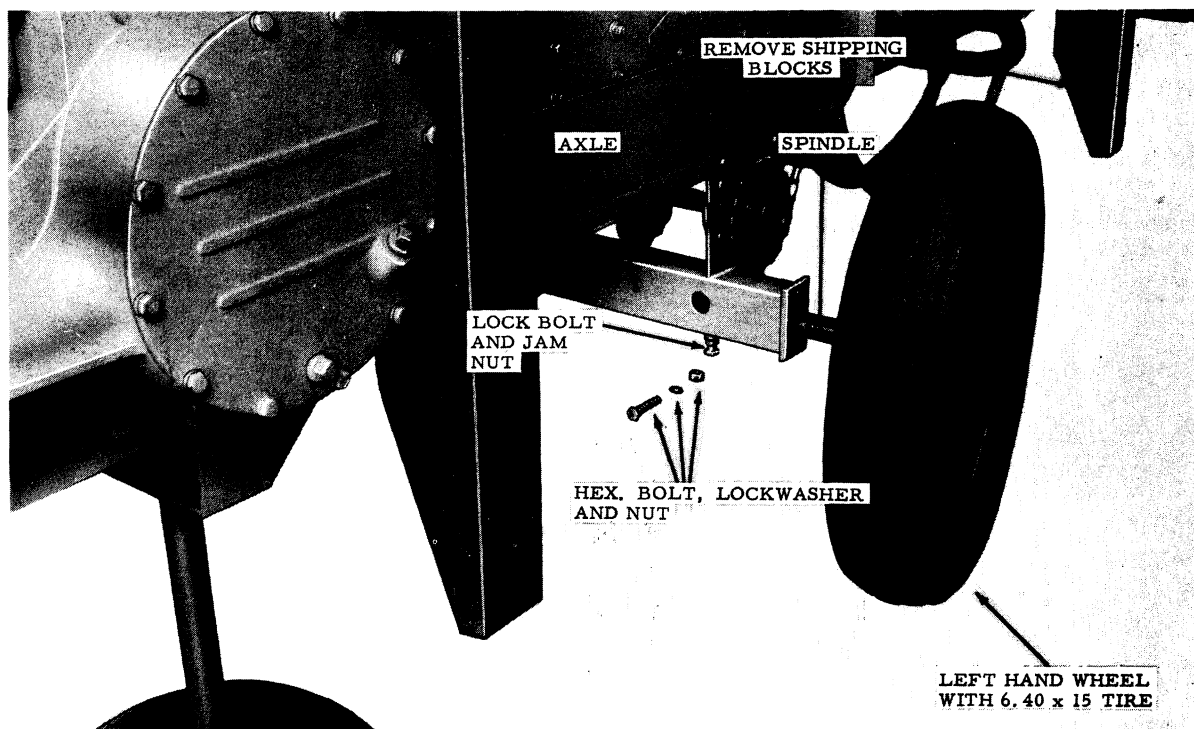

Figure 5. Left Wheel Installation

DRAWBAR INSTALLATION

1. Raise the drawbar latch pin. From the left side, slide the front of the drawbar onto the swing plate of the baler frame. See Figure 6.

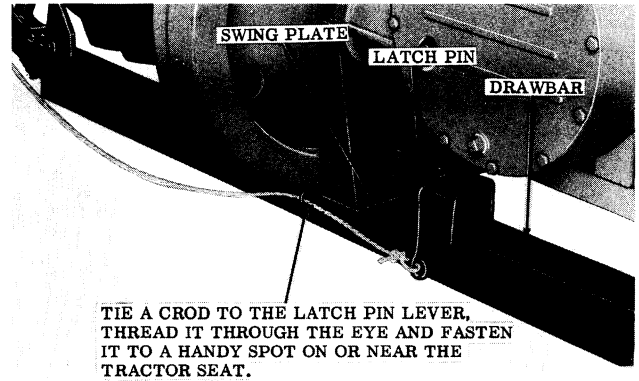

Figure 6. Drawbar on Swing Plate

2. Pivot the rear of the drawbar into the axle bracket. See Figure 7.

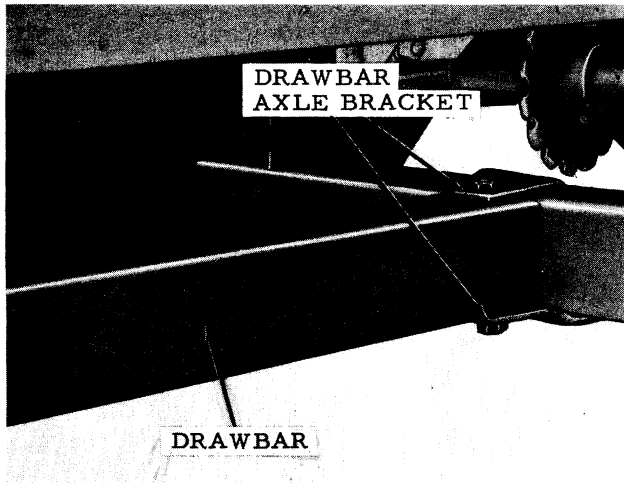

Figure 7. Drawbar Bracket

3. Anchor the drawbar at the rear with a 5/8 x 5" N. F. hex. bolt and flexloc nut. See Figure 7.

4. Pin the drawbar in operating or transport position.

FLYWHEEL INSTALLATION

1. Remove the bolt, lockwasher and flat-washer from the front of the gear box shaft.

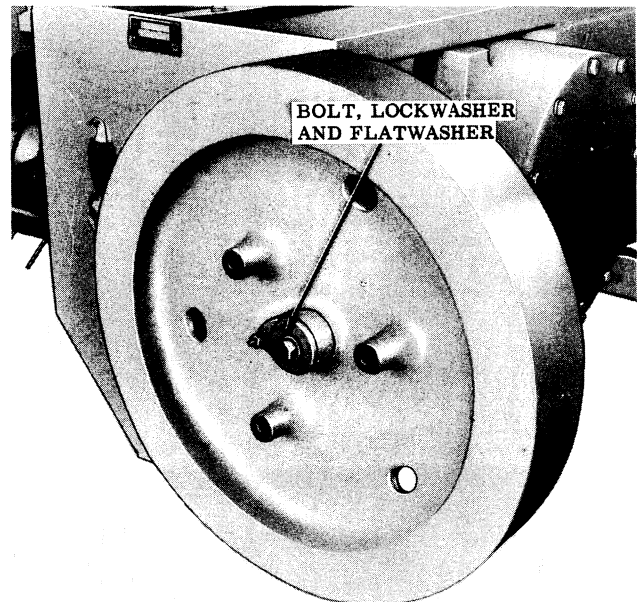

Figure 8. Flywheel Installation

2. Position the flywheel on the splined shaft and secure with the hardware removed. See Figure 8.

<https://www.ebooklibonline.com>

Hello dear friend!

Thank you very much for reading.

Enter the link into your browser.

The full manual is available for immediate download.

<https://www.ebooklibonline.com>