

SERVICE MANUAL

F5 Tier 4B (final) and Stage IV Engine

See the following page for engine model numbers



SERVICE MANUAL

F5BFL413A*B001 , F5BFL413A*B003 , F5BFL413A*B007 , F5BFL413A*B009 ,
F5BFL413D*B002 , F5BFL413D*B003 , F5BFL413F*B002 , F5BFL413F*B003 ,
F5DFL463A*F007 , F5DFL463A*F013 , F5DFL463A*F014 , F5DFL463A*F019 ,
F5DFL463A*F020 , F5DFL463B*F003 , F5DFL463B*F004 , F5DFL463B*F006 ,
F5DFL463C*F001 , F5DFL463C*F002 , F5DFL463C*F004 , F5GFL413A*B003 ,
F5GFL413A*B004 , F5GFL413A*B006 , F5GFL413A*B007 , F5GFL413A*B012 ,
F5GFL413A*B013 , F5HFL463A*F001 , F5HFL463A*F002 , F5HFL463A*F003 ,
F5HFL463A*F004 , F5HFL463A*F005 , F5HFL463A*F006 , F5HFL463A*F007 ,
F5HFL463A*F008 , F5HFL463B*F001 , F5HFL463B*F002 , F5HFL463C*F001 ,
F5HFL463C*F002 , F5HFL463D*F001 , F5HFL463D*F004 , F5HFL463D*F005 ,
F5HFL463D*F006

Contents

INTRODUCTION

Engine.....	10
[10.001] Engine and crankcase	10.1
[10.101] Cylinder heads	10.2
[10.102] Pan and covers	10.3
[10.103] Crankshaft and flywheel.....	10.4
[10.105] Connecting rods and pistons.....	10.5
[10.106] Valve drive and gears	10.6
[10.114] Pump drives	10.7
[10.206] Fuel filters	10.8
[10.218] Fuel injection system.....	10.9
[10.250] Turbocharger and lines.....	10.10
[10.254] Intake and exhaust manifolds and muffler	10.11
[10.304] Engine lubrication system.....	10.12
[10.400] Engine cooling system	10.13
[10.408] Oil cooler and lines.....	10.14
[10.414] Fan and drive	10.15
[10.500] Selective Catalytic Reduction (SCR) exhaust treatment.....	10.16
[10.501] Exhaust Gas Recirculation (EGR) exhaust treatment	10.17
Electrical systems	55
[55.010] Fuel injection system.....	55.1
[55.012] Engine cooling system	55.2
[55.013] Engine oil system	55.3
[55.014] Engine intake and exhaust system.....	55.4
[55.015] Engine control system.....	55.5
[55.201] Engine starting system.....	55.6

<https://www.ebooklibonline.com>

Hello dear friend!

Thank you very much for reading.

Enter the link into your browser.

The full manual is available for immediate download.

<https://www.ebooklibonline.com>

[55.202] Cold start aid	55.7
[55.301] Alternator.....	55.8
[55.988] Selective Catalytic Reduction (SCR) electrical system	55.9
[55.989] Exhaust Gas Recirculation (EGR) electrical system	55.10



INTRODUCTION

Contents

INTRODUCTION

Foreword - Important notice regarding equipment servicing	3
Safety rules	4
Safety rules - Ecology and the environment	5
Basic instructions - Shop and assembly	6
Torque - Minimum tightening torques for normal assembly	8

Foreword - Important notice regarding equipment servicing

All repair and maintenance work listed in this manual must be carried out only by qualified dealership personnel, strictly complying with the instructions given, and using, whenever possible, the special tools.

Anyone who performs repair and maintenance operations without complying with the procedures provided herein shall be responsible for any subsequent damages.

The manufacturer and all the organizations of its distribution chain, including - without limitation - national, regional, or local dealers, reject any responsibility for damages caused by parts and/or components not approved by the manufacturer, including those used for the servicing or repair of the product manufactured or marketed by the manufacturer. In any case, no warranty is given or attributed on the product manufactured or marketed by the manufacturer in case of damages caused by parts and/or components not approved by the manufacturer.

The manufacturer reserves the right to make improvements in design and changes in specifications at any time without notice and without incurring any obligation to install them on units previously sold. Specifications, descriptions, and illustrative material herein are as accurate as known at time of publication but are subject to change without notice.

In case of questions, refer to your CNH Sales and Service Networks.

Safety rules

Personal safety





This is the safety alert symbol. It is used to alert you to potential personal injury hazards. Obey all safety messages that follow this symbol to avoid possible death or injury.

Throughout this manual and on machine decals, you will find the signal words DANGER, WARNING, and CAUTION followed by special instructions. These precautions are intended for the personal safety of you and those working with you.

Read and understand all the safety messages in this manual before you operate or service the machine.

 DANGER indicates a hazardous situation which, if not avoided, will result in death or serious injury. The color associated with DANGER is RED.

 WARNING indicates a hazardous situation which, if not avoided, could result in death or serious injury. The color associated with WARNING is ORANGE.

 CAUTION, used with the safety alert symbol, indicates a hazardous situation which, if not avoided, could result in minor or moderate injury. The color associated with CAUTION is YELLOW.

FAILURE TO FOLLOW DANGER, WARNING, AND CAUTION MESSAGES COULD RESULT IN DEATH OR SERIOUS INJURY.

Machine safety

NOTICE: Notice indicates a situation which, if not avoided, could result in machine or property damage. The color associated with Notice is BLUE.

Throughout this manual you will find the signal word Notice followed by special instructions to prevent machine or property damage. The word Notice is used to address practices not related to personal safety.

Information

NOTE: Note indicates additional information which clarifies steps, procedures, or other information in this manual.

Throughout this manual you will find the word Note followed by additional information about a step, procedure, or other information in the manual. The word Note is not intended to address personal safety or property damage.

Safety rules - Ecology and the environment

Soil, air, and water quality is important for all industries and life in general. When legislation does not yet rule the treatment of some of the substances that advanced technology requires, sound judgment should govern the use and disposal of products of a chemical and petrochemical nature.

Familiarize yourself with the relative legislation applicable to your country, and make sure that you understand this legislation. Where no legislation exists, obtain information from suppliers of oils, filters, batteries, fuels, anti-freeze, cleaning agents, etc., with regard to the effect of these substances on man and nature and how to safely store, use, and dispose of these substances.

Helpful hints

- Avoid the use of cans or other inappropriate pressurized fuel delivery systems to fill tanks. Such delivery systems may cause considerable spillage.
- In general, avoid skin contact with all fuels, oils, acids, solvents, etc. Most of these products contain substances that may be harmful to your health.
- Modern oils contain additives. Do not burn contaminated fuels and or waste oils in ordinary heating systems.
- Avoid spillage when you drain fluids such as used engine coolant mixtures, engine oil, hydraulic fluid, brake fluid, etc. Do not mix drained brake fluids or fuels with lubricants. Store all drained fluids safely until you can dispose of the fluids in a proper way that complies with all local legislation and available resources.
- Do not allow coolant mixtures to get into the soil. Collect and dispose of coolant mixtures properly.
- The air-conditioning system contains gases that should not be released into the atmosphere. Consult an air-conditioning specialist or use a special extractor to recharge the system properly.
- Repair any leaks or defects in the engine cooling system or hydraulic system immediately.
- Do not increase the pressure in a pressurized circuit as this may lead to a component failure.
- Protect hoses during welding. Penetrating weld splatter may burn a hole or weaken hoses, allowing the loss of oils, coolant, etc.

Battery recycling

Batteries and electric accumulators contain several substances that can have a harmful effect on the environment if the batteries are not properly recycled after use. Improper disposal of batteries can contaminate the soil, groundwater, and waterways. CNH strongly recommends that you return all used batteries to a CNH dealer, who will dispose of the used batteries or recycle the used batteries properly. In some countries, this is a legal requirement.



Mandatory battery recycling

NOTE: The following requirements are mandatory in Brazil.

Batteries are made of lead plates and a sulfuric acid solution. Because batteries contain heavy metals such as lead, CONAMA Resolution 401/2008 requires you to return all used batteries to the battery dealer when you replace any batteries. Do not dispose of batteries in your household garbage.

Points of sale are obliged to:

- Accept the return of your used batteries
- Store the returned batteries in a suitable location
- Send the returned batteries to the battery manufacturer for recycling

Basic instructions - Shop and assembly

Shimming

For each adjustment operation, select adjusting shims and measure the adjusting shims individually using a micrometer, then add up the recorded values. Do not rely on measuring the entire shimming set, which may be incorrect, or the rated value shown on each shim.

Rotating shaft seals

For correct rotating shaft seal installation, proceed as follows:

1. Before assembly, allow the seal to soak in the oil it will be sealing for at least thirty minutes.
2. Thoroughly clean the shaft and check that the working surface on the shaft is not damaged.
3. Position the sealing lip facing the fluid.

NOTE: *With hydrodynamic lips, take into consideration the shaft rotation direction and position the grooves so that they will move the fluid towards the inner side of the seal.*

4. Coat the sealing lip with a thin layer of lubricant (use oil rather than grease). Fill the gap between the sealing lip and the dust lip on double lip seals with grease.
5. Insert the seal in its seat and press down using a flat punch or seal installation tool. Do not tap the seal with a hammer or mallet.
6. While you insert the seal, check that the seal is perpendicular to the seat. When the seal settles, make sure that the seal makes contact with the thrust element, if required.
7. To prevent damage to the seal lip on the shaft, position a protective guard during installation operations.

O-ring seals

Lubricate the O-ring seals before you insert them in the seats. This will prevent the O-ring seals from overturning and twisting, which would jeopardize sealing efficiency.

Sealing compounds

Apply a sealing compound on the mating surfaces when specified by the procedure. Before you apply the sealing compound, prepare the surfaces as directed by the product container.

Spare parts

Only use CNH Original Parts or CNH Original Parts.

Only genuine spare parts guarantee the same quality, duration, and safety as original parts, as they are the same parts that are assembled during standard production. Only CNH Original Parts or CNH Original Parts can offer this guarantee.

When ordering spare parts, always provide the following information:

- Machine model (commercial name) and Product Identification Number (PIN)
- Part number of the ordered part, which can be found in the parts catalog

Protecting the electronic and/or electrical systems during charging and welding

To avoid damage to the electronic and/or electrical systems, always observe the following practices:

1. Never make or break any of the charging circuit connections when the engine is running, including the battery connections.
2. Never short any of the charging components to ground.
3. Always disconnect the ground cable from the battery before arc welding on the machine or on any machine attachment.
 - Position the welder ground clamp as close to the welding area as possible.
 - If you weld in close proximity to a computer module, then you should remove the module from the machine.
 - Never allow welding cables to lie on, near, or across any electrical wiring or electronic component while you weld.
4. Always disconnect the negative cable from the battery when charging the battery in the machine with a battery charger.

NOTICE: *If you must weld on the unit, you must disconnect the battery ground cable from the machine battery. The electronic monitoring system and charging system will be damaged if this is not done.*

5. Remove the battery ground cable. Reconnect the cable when you complete welding.

⚠ WARNING

Battery acid causes burns. Batteries contain sulfuric acid.

Avoid contact with skin, eyes or clothing. Antidote (external): Flush with water. Antidote (eyes): flush with water for 15 minutes and seek medical attention immediately. Antidote (internal): Drink large quantities of water or milk. Do not induce vomiting. Seek medical attention immediately.

Failure to comply could result in death or serious injury.

W0111A

Special tools

The special tools that CNH suggests and illustrate in this manual have been specifically researched and designed for use with CNH machines. The special tools are essential for reliable repair operations. The special tools are accurately built and rigorously tested to offer efficient and long-lasting operation.

By using these tools, repair personnel will benefit from:

- Operating in optimal technical conditions
- Obtaining the best results
- Saving time and effort
- Working in safe conditions

Torque - Minimum tightening torques for normal assembly

METRIC NON-FLANGED HARDWARE

NOM. SIZE	CLASS 8.8 BOLT and CLASS 8 NUT		CLASS 10.9 BOLT and CLASS 10 NUT		LOCKNUT CL.8 W/CL8.8 BOLT	LOCKNUT CL.10 W/CL10.9 BOLT
	UNPLATED	PLATED W/ZnCr	UNPLATED	PLATED W/ZnCr		
M4	2.2 N·m (19 lb in)	2.9 N·m (26 lb in)	3.2 N·m (28 lb in)	4.2 N·m (37 lb in)	2 N·m (18 lb in)	2.9 N·m (26 lb in)
M5	4.5 N·m (40 lb in)	5.9 N·m (52 lb in)	6.4 N·m (57 lb in)	8.5 N·m (75 lb in)	4 N·m (36 lb in)	5.8 N·m (51 lb in)
M6	7.5 N·m (66 lb in)	10 N·m (89 lb in)	11 N·m (96 lb in)	15 N·m (128 lb in)	6.8 N·m (60 lb in)	10 N·m (89 lb in)
M8	18 N·m (163 lb in)	25 N·m (217 lb in)	26 N·m (234 lb in)	35 N·m (311 lb in)	17 N·m (151 lb in)	24 N·m (212 lb in)
M10	37 N·m (27 lb ft)	49 N·m (36 lb ft)	52 N·m (38 lb ft)	70 N·m (51 lb ft)	33 N·m (25 lb ft)	48 N·m (35 lb ft)
M12	64 N·m (47 lb ft)	85 N·m (63 lb ft)	91 N·m (67 lb ft)	121 N·m (90 lb ft)	58 N·m (43 lb ft)	83 N·m (61 lb ft)
M16	158 N·m (116 lb ft)	210 N·m (155 lb ft)	225 N·m (166 lb ft)	301 N·m (222 lb ft)	143 N·m (106 lb ft)	205 N·m (151 lb ft)
M20	319 N·m (235 lb ft)	425 N·m (313 lb ft)	440 N·m (325 lb ft)	587 N·m (433 lb ft)	290 N·m (214 lb ft)	400 N·m (295 lb ft)
M24	551 N·m (410 lb ft)	735 N·m (500 lb ft)	762 N·m (560 lb ft)	1016 N·m (750 lb ft)	501 N·m (370 lb ft)	693 N·m (510 lb ft)

NOTE: M4 through M8 hardware torque specifications are shown in pound-inches. M10 through M24 hardware torque specifications are shown in pound-feet.

METRIC FLANGED HARDWARE

NOM. SIZE	CLASS 8.8 BOLT and CLASS 8 NUT		CLASS 10.9 BOLT and CLASS 10 NUT		LOCKNUT CL.8 W/CL8.8 BOLT	LOCKNUT CL.10 W/CL10.9 BOLT
	UNPLATED	PLATED W/ZnCr	UNPLATED	PLATED W/ZnCr		
M4	2.4 N·m (21 lb in)	3.2 N·m (28 lb in)	3.5 N·m (31 lb in)	4.6 N·m (41 lb in)	2.2 N·m (19 lb in)	3.1 N·m (27 lb in)
M5	4.9 N·m (43 lb in)	6.5 N·m (58 lb in)	7.0 N·m (62 lb in)	9.4 N·m (83 lb in)	4.4 N·m (39 lb in)	6.4 N·m (57 lb in)
M6	8.3 N·m (73 lb in)	11 N·m (96 lb in)	12 N·m (105 lb in)	16 N·m (141 lb in)	7.5 N·m (66 lb in)	11 N·m (96 lb in)
M8	20 N·m (179 lb in)	27 N·m (240 lb in)	29 N·m (257 lb in)	39 N·m (343 lb in)	18 N·m (163 lb in)	27 N·m (240 lb in)
M10	40 N·m (30 lb ft)	54 N·m (40 lb ft)	57 N·m (42 lb ft)	77 N·m (56 lb ft)	37 N·m (27 lb ft)	53 N·m (39 lb ft)
M12	70 N·m (52 lb ft)	93 N·m (69 lb ft)	100 N·m (74 lb ft)	134 N·m (98 lb ft)	63 N·m (47 lb ft)	91 N·m (67 lb ft)
M16	174 N·m (128 lb ft)	231 N·m (171 lb ft)	248 N·m (183 lb ft)	331 N·m (244 lb ft)	158 N·m (116 lb ft)	226 N·m (167 lb ft)
M20	350 N·m (259 lb ft)	467 N·m (345 lb ft)	484 N·m (357 lb ft)	645 N·m (476 lb ft)	318 N·m (235 lb ft)	440 N·m (325 lb ft)
M24	607 N·m (447 lb ft)	809 N·m (597 lb ft)	838 N·m (618 lb ft)	1118 N·m (824 lb ft)	552 N·m (407 lb ft)	

IDENTIFICATION

Metric Hex head and carriage bolts, classes 5.6 and up

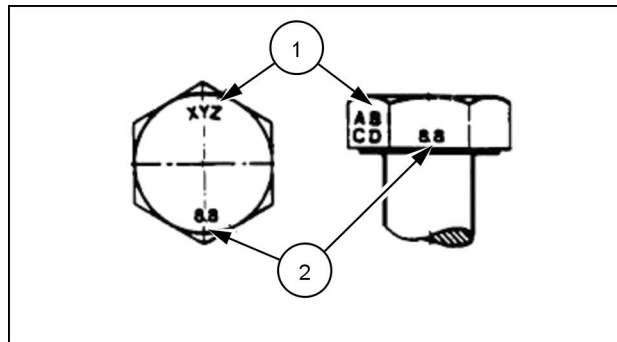

20083680 1

1. Manufacturer's Identification
2. Property Class

Metric Hex nuts and locknuts, classes 05 and up

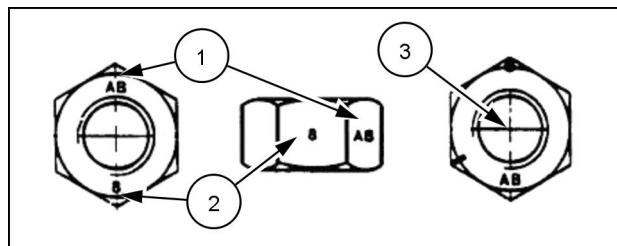

20083681 2

1. Manufacturer's Identification
2. Property Class
3. Clock Marking of Property Class and Manufacturer's Identification (Optional), i.e. marks **60 °** apart indicate Class 10 properties, and marks **120 °** apart indicate Class 8.

INCH NON-FLANGED HARDWARE

NOMINAL SIZE	SAE GRADE 5 BOLT and NUT		SAE GRADE 8 BOLT and NUT		LOCKNUT GrB W/ Gr5 BOLT	LOCKNUT GrC W/ Gr8 BOLT
	UN-PLATED or PLATED SILVER	PLATED W/ZnCr GOLD	UN-PLATED or PLATED SILVER	PLATED W/ZnCr GOLD		
1/4	8 N·m (71 lb in)	11 N·m (97 lb in)	12 N·m (106 lb in)	16 N·m (142 lb in)	8.5 N·m (75 lb in)	12.2 N·m (109 lb in)
5/16	17 N·m (150 lb in)	23 N·m (204 lb in)	24 N·m (212 lb in)	32 N·m (283 lb in)	17.5 N·m (155 lb in)	25 N·m (220 lb in)
3/8	30 N·m (22 lb ft)	40 N·m (30 lb ft)	43 N·m (31 lb ft)	57 N·m (42 lb ft)	31 N·m (23 lb ft)	44 N·m (33 lb ft)
7/16	48 N·m (36 lb ft)	65 N·m (48 lb ft)	68 N·m (50 lb ft)	91 N·m (67 lb ft)	50 N·m (37 lb ft)	71 N·m (53 lb ft)
1/2	74 N·m (54 lb ft)	98 N·m (73 lb ft)	104 N·m (77 lb ft)	139 N·m (103 lb ft)	76 N·m (56 lb ft)	108 N·m (80 lb ft)
9/16	107 N·m (79 lb ft)	142 N·m (105 lb ft)	150 N·m (111 lb ft)	201 N·m (148 lb ft)	111 N·m (82 lb ft)	156 N·m (115 lb ft)
5/8	147 N·m (108 lb ft)	196 N·m (145 lb ft)	208 N·m (153 lb ft)	277 N·m (204 lb ft)	153 N·m (113 lb ft)	215 N·m (159 lb ft)
3/4	261 N·m (193 lb ft)	348 N·m (257 lb ft)	369 N·m (272 lb ft)	491 N·m (362 lb ft)	271 N·m (200 lb ft)	383 N·m (282 lb ft)
7/8	420 N·m (310 lb ft)	561 N·m (413 lb ft)	594 N·m (438 lb ft)	791 N·m (584 lb ft)	437 N·m (323 lb ft)	617 N·m (455 lb ft)
1	630 N·m (465 lb ft)	841 N·m (620 lb ft)	890 N·m (656 lb ft)	1187 N·m (875 lb ft)	654 N·m (483 lb ft)	924 N·m (681 lb ft)

NOTE: For Imperial Units, *1/4 in* and *5/16 in* hardware torque specifications are shown in pound-inches. *3/8 in* through *1 in* hardware torque specifications are shown in pound-feet.

INCH FLANGED HARDWARE

NOM- INAL SIZE	SAE GRADE 5 BOLT and NUT		SAE GRADE 8 BOLT and NUT		LOCKNUT GrF W/ Gr5 BOLT	LOCKNUT GrG W/ Gr8 BOLT
	UNPLATED or PLATED SILVER	PLATED W/ZnCr GOLD	UNPLATED or PLATED SILVER	PLATED W/ZnCr GOLD		
1/4	9 N·m (80 lb in)	12 N·m (106 lb in)	13 N·m (115 lb in)	17 N·m (150 lb in)	8 N·m (71 lb in)	12 N·m (106 lb in)
5/16	19 N·m (168 lb in)	25 N·m (221 lb in)	26 N·m (230 lb in)	35 N·m (310 lb in)	17 N·m (150 lb in)	24 N·m (212 lb in)
3/8	33 N·m (25 lb ft)	44 N·m (33 lb ft)	47 N·m (35 lb ft)	63 N·m (46 lb ft)	30 N·m (22 lb ft)	43 N·m (32 lb ft)
7/16	53 N·m (39 lb ft)	71 N·m (52 lb ft)	75 N·m (55 lb ft)	100 N·m (74 lb ft)	48 N·m (35 lb ft)	68 N·m (50 lb ft)
1/2	81 N·m (60 lb ft)	108 N·m (80 lb ft)	115 N·m (85 lb ft)	153 N·m (113 lb ft)	74 N·m (55 lb ft)	104 N·m (77 lb ft)
9/16	117 N·m (86 lb ft)	156 N·m (115 lb ft)	165 N·m (122 lb ft)	221 N·m (163 lb ft)	106 N·m (78 lb ft)	157 N·m (116 lb ft)
5/8	162 N·m (119 lb ft)	216 N·m (159 lb ft)	228 N·m (168 lb ft)	304 N·m (225 lb ft)	147 N·m (108 lb ft)	207 N·m (153 lb ft)
3/4	287 N·m (212 lb ft)	383 N·m (282 lb ft)	405 N·m (299 lb ft)	541 N·m (399 lb ft)	261 N·m (193 lb ft)	369 N·m (272 lb ft)
7/8	462 N·m (341 lb ft)	617 N·m (455 lb ft)	653 N·m (482 lb ft)	871 N·m (642 lb ft)	421 N·m (311 lb ft)	594 N·m (438 lb ft)
1	693 N·m (512 lb ft)	925 N·m (682 lb ft)	979 N·m (722 lb ft)	1305 N·m (963 lb ft)	631 N·m (465 lb ft)	890 N·m (656 lb ft)

IDENTIFICATION

Inch Bolts and free-spinning nuts

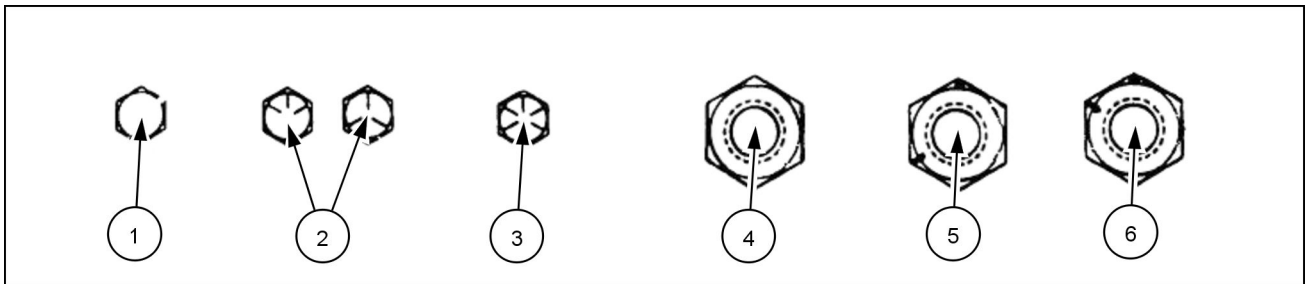

20083682 3

Grade Marking Examples

SAE Grade Identification			
1	Grade 2 - No Marks	4	Grade 2 Nut - No Marks
2	Grade 5 - Three Marks	5	Grade 5 Nut - Marks 120 ° Apart
3	Grade 8 - Five Marks	6	Grade 8 Nut - Marks 60 ° Apart

Inch Lock Nuts, All Metal (Three optional methods)

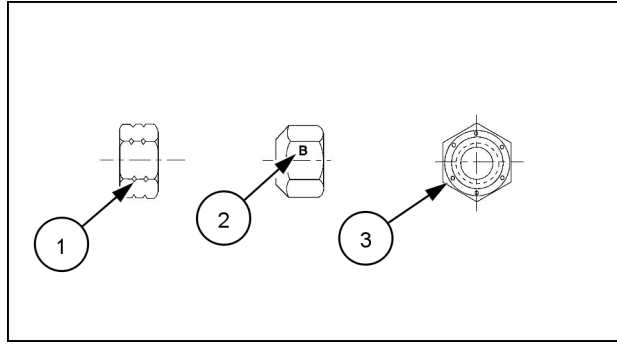

20090268 4

Grade Identification

Grade	Corner Marking Method (1)	Flats Marking Method (2)	Clock Marking Method (3)
Grade A	No Notches	No Mark	No Marks
Grade B	One Circumferential Notch	Letter B	Three Marks
Grade C	Two Circumferential Notches	Letter C	Six Marks



SERVICE MANUAL

Engine

**F5BFL413A*B001 , F5BFL413A*B003 , F5BFL413A*B007 , F5BFL413A*B009 ,
F5BFL413D*B002 , F5BFL413D*B003 , F5BFL413F*B002 , F5BFL413F*B003 ,
F5DFL463A*F007 , F5DFL463A*F013 , F5DFL463A*F014 , F5DFL463A*F019 ,
F5DFL463A*F020 , F5DFL463B*F003 , F5DFL463B*F004 , F5DFL463B*F006 ,
F5DFL463C*F001 , F5DFL463C*F002 , F5DFL463C*F004 , F5GFL413A*B003 ,
F5GFL413A*B004 , F5GFL413A*B006 , F5GFL413A*B007 , F5GFL413A*B012 ,
F5GFL413A*B013 , F5HFL463A*F001 , F5HFL463A*F002 , F5HFL463A*F003 ,
F5HFL463A*F004 , F5HFL463A*F005 , F5HFL463A*F006 , F5HFL463A*F007 ,
F5HFL463A*F008 , F5HFL463B*F001 , F5HFL463B*F002 , F5HFL463C*F001 ,
F5HFL463C*F002 , F5HFL463D*F001 , F5HFL463D*F004 , F5HFL463D*F005 ,
F5HFL463D*F006**

Contents

Engine - 10

[10.001] Engine and crankcase	10.1
[10.101] Cylinder heads	10.2
[10.102] Pan and covers	10.3
[10.103] Crankshaft and flywheel.....	10.4
[10.105] Connecting rods and pistons	10.5
[10.106] Valve drive and gears	10.6
[10.114] Pump drives	10.7
[10.206] Fuel filters	10.8
[10.218] Fuel injection system.....	10.9
[10.250] Turbocharger and lines.....	10.10
[10.254] Intake and exhaust manifolds and muffler	10.11
[10.304] Engine lubrication system.....	10.12
[10.400] Engine cooling system	10.13
[10.408] Oil cooler and lines.....	10.14
[10.414] Fan and drive	10.15
[10.500] Selective Catalytic Reduction (SCR) exhaust treatment.....	10.16
[10.501] Exhaust Gas Recirculation (EGR) exhaust treatment	10.17



Engine - 10

Engine and crankcase - 001

F5BFL413A*B001 , F5BFL413A*B003 , F5BFL413A*B007 , F5BFL413A*B009 ,
F5BFL413D*B002 , F5BFL413D*B003 , F5BFL413F*B002 , F5BFL413F*B003 ,
F5DFL463A*F007 , F5DFL463A*F013 , F5DFL463A*F014 , F5DFL463A*F019 ,
F5DFL463A*F020 , F5DFL463B*F003 , F5DFL463B*F004 , F5DFL463B*F006 ,
F5DFL463C*F001 , F5DFL463C*F002 , F5DFL463C*F004 , F5GFL413A*B003 ,
F5GFL413A*B004 , F5GFL413A*B006 , F5GFL413A*B007 , F5GFL413A*B012 ,
F5GFL413A*B013 , F5HFL463A*F001 , F5HFL463A*F002 , F5HFL463A*F003 ,
F5HFL463A*F004 , F5HFL463A*F005 , F5HFL463A*F006 , F5HFL463A*F007 ,
F5HFL463A*F008 , F5HFL463B*F001 , F5HFL463B*F002 , F5HFL463C*F001 ,
F5HFL463C*F002 , F5HFL463D*F001 , F5HFL463D*F004 , F5HFL463D*F005 ,
F5HFL463D*F006

Contents

Engine - 10

Engine and crankcase - 001

TECHNICAL DATA

Engine

General specification	3
General specification (*)	3
Service limits	3

SERVICE

Engine

Service instruction - Finding Top Dead Center (TDC)	6
Timing adjust	8

Crankcase

Bore - Measure	9
----------------------	---

(*) See content for specific models

Engine - General specification

Specifications	
Cycle	4 stroke
Fuel type	Diesel
Aspiration	Turbocharged after-cooled
Type of combustion	Direct injection
Number of cylinders	4
Cylinder orientation	In-line
Number of valves per cylinder	2
Bore	99 mm (3.90 in)
Stroke	110 mm (4.33 in)
Displacement	3.4 l (207 in³)
Compression ratio	17.5:1
Firing order	1, 3, 4, 2
Maximum power rating	55 kW (75 Hp) @ 2300 RPM
Engine speed	
Low idle	1125 - 1175 RPM
High idle	2475 - 2525 RPM

Engine - General specification

F5BFL413A*B001	
F5BFL413A*B003	
F5BFL413A*B007	
F5BFL413A*B009	
F5BFL413D*B002	
F5BFL413D*B003	
F5BFL413F*B002	
F5BFL413F*B003	
F5GFL413A*B003	
F5GFL413A*B004	
F5GFL413A*B006	
F5GFL413A*B007	
F5GFL413A*B012	
F5GFL413A*B013	

Specifications	
Cycle	4 stroke
Fuel type	Diesel
Aspiration	Turbocharged after-cooled
Type of combustion	Direct injection
Number of cylinders	4
Cylinder orientation	In-line
Number of valves per cylinder	4
Bore	99 mm (3.90 in)
Stroke	110 mm (4.33 in)
Displacement	3.4 l (207 in³)
Compression ratio	17.5:1
Firing order	1, 3, 4, 2

Engine - Service limits

Timing	
Intake	
- Start before Top Dead Center (TDC)	19 °
- End after Bottom Dead Center (BDC)	37 °
Exhaust	

- Start before BDC	61 °
- End after TDC	21 °
Fuel system	
Injection Type	Bosch CP4.1
Nozzle type	Bosch CRI2.2
Injection sequence	1 - 3 - 4 - 2
Cylinder block and piston	
Cylinder bore	99.000 - 99.020 mm (3.8976 - 3.8984 in)
Pistons	
- Outside diameter	98.908 - 98.918 mm (3.8940 - 3.8944 in)
- Pin bore	36.003 - 36.009 mm (1.4174 - 1.4177 in)
Clearance between cylinder bore and piston	0.082 - 0.112 mm (0.0032 - 0.0044 in)
Piston protrusion	-0.22 - 0.07 mm (-0.0087 - 0.0028 in)
Piston pin	35.990 - 35.996 mm (1.4169 - 1.4172 in)
Clearance between piston pin and bore	0.004 - 0.019 mm (0.0002 - 0.0007 in)
Piston ring lands	
- Top	2.21 mm (0.0870 in)
- Middle	2.050 - 2.070 mm (0.0807 - 0.0815 in)
- Bottom	2.540 - 2.560 mm (0.1000 - 0.1008 in)
Piston rings	
- Top	2.068 - 2.097 mm (0.0814 - 0.0826 in)
- Middle	1.970 - 1.990 mm (0.0776 - 0.0783 in)
- Bottom	2.470 - 2.490 mm (0.0972 - 0.0980 in)
Clearance between Rings and Lands	
- Top	0.06 - 0.100 mm (0.0024 - 0.0039 in)
- Middle	0.06 - 0.100 mm (0.0024 - 0.0039 in)
- Bottom	0.05 - 0.09 mm (0.0020 - 0.0035 in)
Piston ring end gap	
- Top	0.20 - 0.35 mm (0.0079 - 0.0138 in)
- Middle	0.60 - 0.80 mm (0.0236 - 0.0315 in)
- Bottom	0.30 - 0.60 mm (0.0118 - 0.0236 in)
Camshaft bore inside diameter	
- 1	59.222 - 59.248 mm (2.3316 - 2.3326 in)
- 2-3-4	50.069 - 50.119 mm (1.9712 - 1.9732 in)
- 5	40.069 - 40.119 mm (1.5775 - 1.5795 in)
Camshaft Journals	
- 1	53.995 - 54.045 mm (2.1258 - 2.1278 in)
- 2-3-4	49.975 - 50.025 mm (1.9675 - 1.9695 in)
- 5	39.975 - 40.025 mm (1.5738 - 1.5758 in)
Clearance between cam bearings and journals	0.038 - 0.162 mm (0.0015 - 0.0064 in)
Cam lift	
- Intake	6.213 mm (0.2446 in)
- Exhaust	5.5105 mm (0.2169 in)
Tappets	
- Housing	15.000 - 15.018 mm (0.5906 - 0.5913 in)
- Tappet (Upper and Lower)	15.924 - 15.954 mm (0.6269 - 0.6281 in)
- Tappet (Middle)	15.960 - 15.975 mm (0.6283 - 0.6289 in)
Clearance between tappets and housing	0.03 - 0.068 mm (0.0012 - 0.0027 in)
Connecting rod	
Small end bearing housing	39.460 - 39.490 mm (1.5535 - 1.5547 in)
Big end bearing housing	67.833 - 67.841 mm (2.6706 - 2.6709 in)
Small end bearing inside diameter	39.570 - 39.595 mm (1.5579 - 1.5589 in)
Small end bearing inside diameter (installed)	36.010 - 36.020 mm (1.4177 - 1.4181 in)
Big end bearing thickness	
- Red	1.875 - 1.884 mm (0.0738 - 0.0742 in)

- Blue	1.883 - 1.892 mm (0.0741 - 0.0745 in)
- Green	1.891 - 1.900 mm (0.0744 - 0.0748 in)
Clearance between piston pin and small end bearing	0.011 - 0.024 mm (0.0004 - 0.0009 in)
Maximum allowable twist for connecting rod	0.09 mm (0.0035 in) @ 125 mm (4.9213 in)
Crankshaft	
Main journal diameter (1-2-3-4)	76.182 - 76.208 mm (2.9993 - 3.0003 in)
Main journal diameter (5)	83.182 - 83.208 mm (3.2749 - 3.2759 in)
Rod journals	68.015 - 68.038 mm (2.677 - 2.679 in)
Main bearing thickness	2.165 - 2.174 mm (0.0852 - 0.0856 in)
Main bore diameter (1-2-3-4)	80.588 - 80.514 mm (3.1728 - 3.1698 in)
Main bore diameter (5)	87.588 - 87.614 mm (3.4483 - 3.4494 in)
Clearance between main bearings and journals (1-2-3-4)	0.064 - 0.095 mm (0.0025 - 0.0037 in)
Clearance between main bearings and journals (5)	0.059 - 0.100 mm (0.0023 - 0.0039 in)
Clearance between rod bearing and journals	0.033 - 0.041 mm (0.0013 - 0.0016 in)
Main journal width for thrust bearing on crankshaft	31.85 - 32.150 mm (1.2539 - 1.2657 in)
Main journal width for thrust bearing in cylinder block	32.50 - 32.55 mm (1.2795 - 1.2815 in)
Thrust bearing thickness	2.51 - 2.56 mm (0.0988 - 0.1008 in)
Clearance between the crankshaft and thrust bearing	0.095 - 0.270 mm (0.0037 - 0.0106 in)
Cylinder head and valves	
Valve guide seats in cylinder head	12.960 - 12.995 mm (0.5102 - 0.5116 in)
Valve Guides	
- Inside diameter	8.023 - 8.038 mm (0.3159 - 0.3165 in)
- Outside diameter	12.950 - 12.985 mm (0.5098 - 0.5112 in)
Intake valves	
- Valve stem diameter	7.985 - 8.000 mm (0.3144 - 0.3150 in)
- Valve face angle	60 °
Exhaust valves	
- Valve stem diameter	7.985 - 8.000 mm (0.3144 - 0.3150 in)
- Valve face angle	60 °
Clearance between valve stem and guide	0.040 - 0.053 mm (0.0016 - 0.0021 in)
Valve seat in the cylinder head	
- Intake	39.987 - 40.013 mm (1.5743 - 1.5753 in)
- Exhaust	43.787 - 43.813 mm (1.7239 - 1.7249 in)
Intake valve seat	
- Outside diameter	40.063 - 40.088 mm (1.5773 - 1.5783 in)
- Seat angle	60 °
Exhaust valve seat	
- Outside diameter	43.863 - 43.880 mm (1.7269 - 1.7276 in)
- Seat angle	60 °
Valve recess	
- Intake	0.3 - 0.7 mm (0.0118 - 0.0276 in)
- Exhaust	0.3 - 0.7 mm (0.0118 - 0.0276 in)
Valve spring height	
- Free spring	44.6 mm (1.756 in)
- Under a load of 256 - 284 N (58 - 64 lb)	34 mm (1.339 in)
- Under a load of 500 - 556 N (112 - 125 lb)	23.8 mm (0.937 in)
Injector protrusion	1.7 - 2.35 mm (0.0669 - 0.0925 in)
Rocker Assembly	
- Rocker Shaft Outside diameter	18.979 - 19.000 mm (0.7472 - 0.7480 in)
- Rockers	19.020 - 19.033 mm (0.7488 - 0.7493 in)
Clearance between rockers and shaft	0.020 - 0.054 mm (0.0008 - 0.0021 in)

Engine - Service instruction - Finding Top Dead Center (TDC)

For engines with access to the timing hole in the flywheel housing

1. Fit the tool **380000150** through the case (1) and into the port on the flywheel, as shown.
2. Use the tool **380000988** (1) to rotate the flywheel until the notch (2) is visible in the inspection hole and cylinder one is at Top Dead Center (TDC).

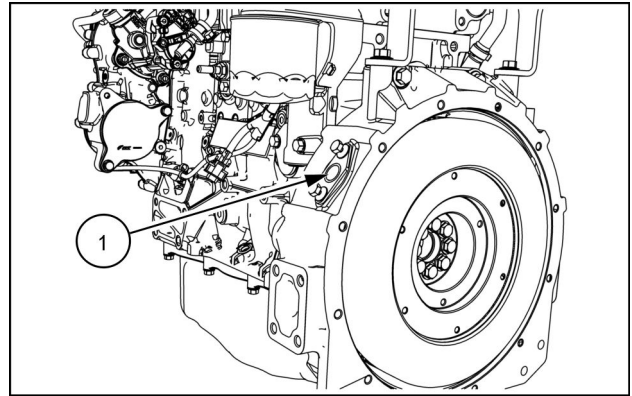

NHVM12ENG004AA 1

For engines without access to the timing hole in the flywheel housing

NOTE: Prior to performing this procedure, ensure that the engine is near cylinder one TDC on the compression stroke by verifying that both push rods or rocker arm assemblies on number one cylinder are loose. If both push rods or rocker arms are tight, rotate the engine one full revolution on the crankshaft, in the direction of normal operation, and re check the push rods or rocker arm assemblies.

1. Fabricate a wire pointer (1) as shown and attach it to a front cover bolt (2) that is located close to the vibration damper (3). Position the pointer approximately **1.6 mm (0.0625 in)** from the damper.
2. Rotate the engine in the direction of normal operation.
3. Pry down on the cylinder number one intake valve and insert a **6.35 mm (0.25 in)** spacer between the valve stem and rocker arm tip to hold the valve open.

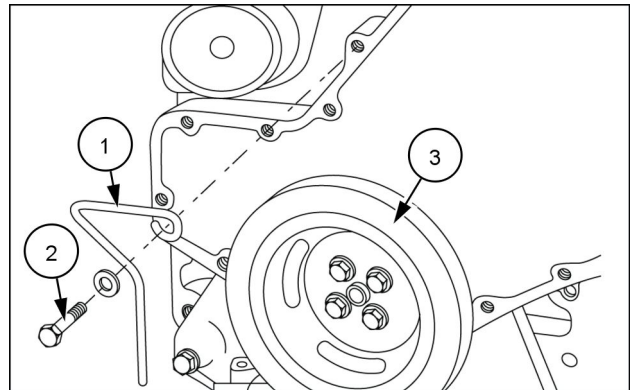

93110987 2

4. Slowly rotate the engine to TDC by hand until the piston contacts the valve and stops rotation. Make a reference mark (1) on the damper at the pointer.
5. Rotate the engine counter clockwise as viewed from the front.
6. Remove the spacer.
7. Rotate the engine clockwise approximately **90 °** past TDC.
8. Pry down on cylinder number one intake valve and again insert the spacer between the valve stem and rocker arm tip to hold the valve open.

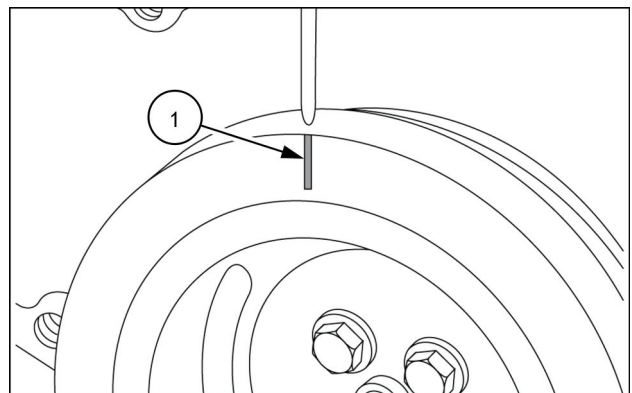

93110988 3



Suggest:

For more complete manuals. Please go to the home page.

<https://www.ebooklibonline.com>

If the above button click is invalid. Please download this document first, and then click the above link to download the complete manual.

Thank you so much for reading

9. Slowly rotate the engine back to TDC by hand until the piston contacts the valve and stops rotation. Make another reference mark **(1)** on the damper at the pointer.
10. Rotate the engine clockwise.
11. Remove the spacer.

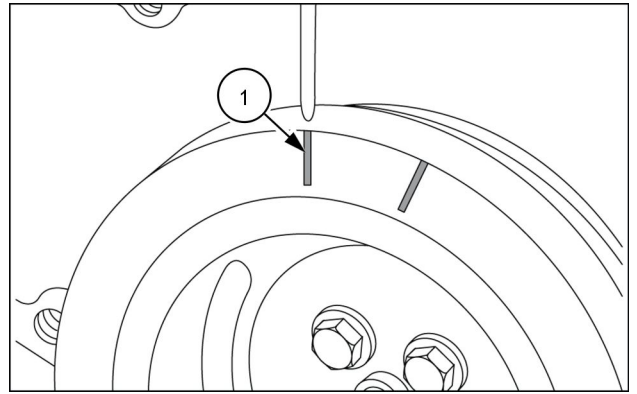

93110989 4

12. Use a flexible tape measure and make a reference mark **(1)** at the center point between the two marks made on the damper. This mark represents true TDC.
13. Align the center damper mark to the pointer. This is cylinder number one at TDC on the compression stroke.

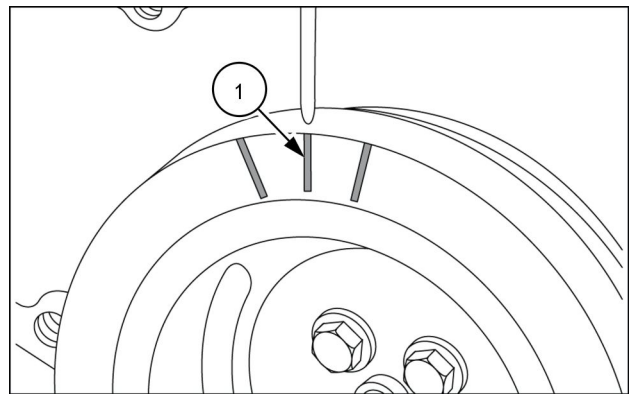

93110990 5

Engine - Timing adjust

1. Align the locating dowel (1) on the camshaft with the corresponding hole (2) on the camshaft gear.

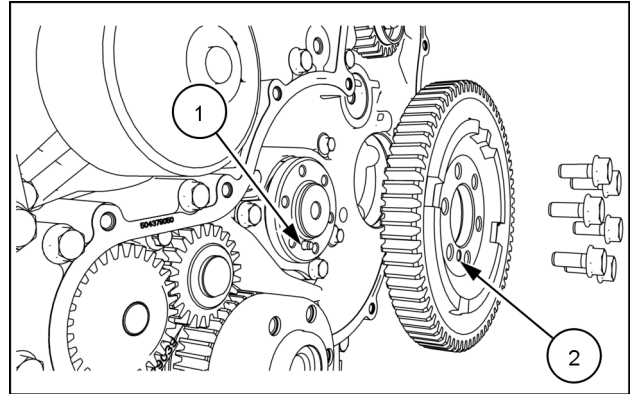

NHIL14ENG0654AA 1

2. Align the two timing dots (2) on the camshaft gear with the chamfered tooth (1) on the crankshaft gear.

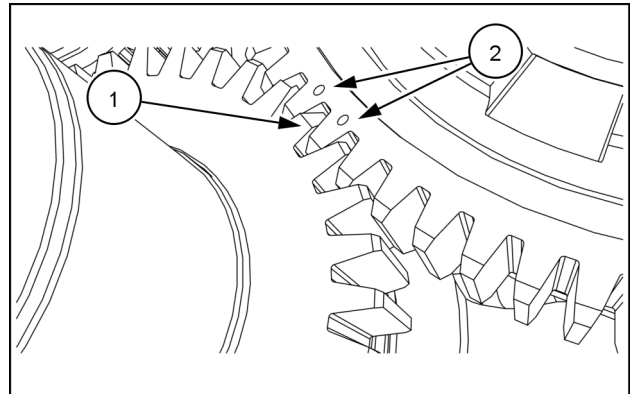

NHIL14ENG0655AA 2

3. Install the M8 x 20 camshaft gear bolts (1).
4. Torque the camshaft gear bolts (1) to **25 N·m (18 lb ft)**.

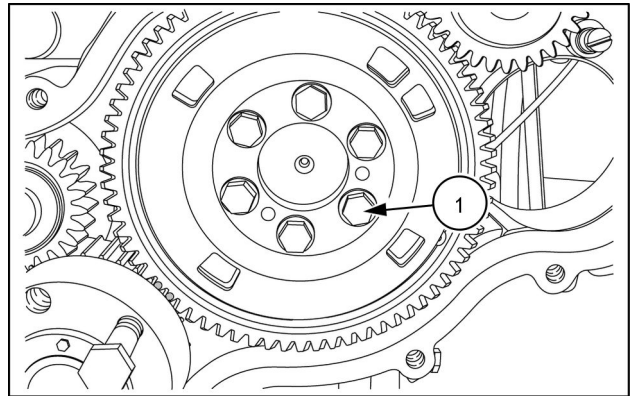

NHIL12ENG0023AA 3

<https://www.ebooklibonline.com>

Hello dear friend!

Thank you very much for reading.

Enter the link into your browser.

The full manual is available for immediate download.

<https://www.ebooklibonline.com>