

1816 UNI-LOADER

TABLE OF CONTENTS

SERIES/SECTION	SECTION NO.	FORM NO.
10 SERIES - GENERAL		
Maintenance and Lubrication	1050	9-72555
Torque Chart	1051	9-72555
20 SERIES - ENGINE		
Engine Removal, Installation and Drive Belts	2050	9-72555
4 Cycle Valve in Head Engine	2052	9-72555
Trouble Shooting a Hard Starting Engine and D61880 Starter (Square Housing)	2052A	9-72555
40 SERIES - EQUIPMENT HYDRAULICS		
Hydraulic Diagrams, Maintenance, Trouble Shooting and Adjustments	4011	9-72555
Equipment Pump	4012	9-72555
Loader Control Valve	4020	9-72555
Auxiliary Control Valve	4031	9-72555
Lift, Tilt and Grapple Cylinders	4050	9-72555
60 SERIES - POWER TRAIN		
Centrifugal Clutch	6021	9-72555
Wheels and Tires	6023	9-72555
Drive Chains and Axles	6024	9-72555
Vickers Hydrostatic System Diagrams and Operation	6030	9-72555
Sundstrand Hydrostatic System Diagrams and Operation ...	6030A	9-72555
Trouble Shooting, Testing and Adjustments for Vickers Hydrostatic System	6031	9-72555
Trouble Shooting, Testing and Relief Valve Adjustment for Sundstrand Hydrostatic System	6031A	9-72555
Vickers Hydrostatic Pump	6032	9-72555
Sundstrand Hydrostatic Pump	6032A	9-72555
Hydrostatic Motor	6033	9-72555
Hydrostatic Controls for Vickers Pumps	6034	9-72555
Hydrostatic Controls for Sundstrand Pumps	6034A	9-72555
70 SERIES - BRAKES		
Parking Brake	7017	9-72555
80 SERIES - ELECTRICAL SYSTEM		
Wiring Diagrams	8011	9-72555
System Components	Refer to Sections 2052 and 2052A	
90 SERIES - MOUNTED EQUIPMENT		
Loader	9011	9-72555
Roll-over Protection Structure	9019	9-72555

Reprinted



SAFETY RULES



Read operator's manual to familiarize yourself with control lever functions.

Never place any part of your body between the chassis and loader frame and/or lift and tilt cylinders if service being performed prohibits the use of a safety stop.

Whenever the bucket must be raised to aid in servicing, block the bucket in place with lift cylinder stops or a suitable safety stand.

When working in the area of the fan belt with the engine running, avoid loose clothing if possible, and use extreme caution.

Keep hand and fingers clear of drive chains if running with chain compartment cover removed.

When performing checks and tests on the equipment hydraulic system or hydrostatic system, DO NOT deviate from the written procedure.

Operate controls from the operator's seat only.

This is a one man machine, no riders allowed.

1816 SERVICE MANUAL

Introduction

This service manual has been prepared with the latest service information available. Trouble shooting, removal, disassembly, inspection and installation procedures coupled with complete specifications and tightening references can be found in most sections. Some sections will have exploded views without accompanying text due to the simplicity of the procedure. This service manual is one of the most important tools available to the service technician. It is an invaluable aid in properly performing any phase of service.

The terms right hand and left hand as used in this manual indicate the right and left sides of the machine as viewed from the operator's seat for proper operation of the machine or attachment.

The information contained in this manual is current at the time of printing.

Table of Contents

The preceding page contains a Table of Contents which list the Series number and title, and the sections contained in each series. The individual sections, where required, will have a Table of Contents on the second page of that section.

Page Numbers

All page numbers consist of two sets of

digits separated by a dash, such as 4011-9. The digits preceding the dash identify the section. The digits following the dash represent the consecutive page number within that section. Page numbers will be found at the upper right or left of each page.

Text

If this manual covers more than one machine, or different models of component parts (planetary axles, gear boxes, control valves, etc.) the procedures will apply to all unless otherwise noted.

Illustrations

Where possible, illustrations are placed as close as possible to the accompanying text and should be used as part of the text.

Serial and Model Numbers

When requisitioning repair or replacement parts it may be necessary to furnish the parts department with one or both numbers. Serial and model numbers will found in the following locations.

Machine - Plate fastened to instrument panel. Also stamped on frame at base of fuel tank fill tube.

Engine - Right hand side of block above oil filter.

MAINTENANCE CHART

NOTE: This chart is based on maximum intervals. Increase intervals if machine operates in severe conditions.

INTERVAL	SERVICE	INSTRUCTIONS
Run-In Period After First 2 Hours	Change engine oil. Check wheel nut torque until stable (40 to 50 foot-pounds).	Section 2052
Run-In Period After First 25 Hours	Change hydraulic oil. Change hydraulic oil filter.	Section 4011 Section 4011
Every 5 Hours or Twice Daily	Check engine oil level.	Section 2052
Daily	Grease loader pivot points. Fill the fuel tank. Inspect air cleaner element, clean if required. Clean oil cooler of all obstructions. Visually check machine for broken missing or loose parts. Also check for leaks under machine.	
Twice a Week or Every 25 Hours	Change engine crankcase oil.	Section 2052
Weekly	Grease control lever pivots. Check hydraulic oil level. Check battery electrolyte level. Check tire pressure. Inspect all pump drive belts.	Section 4011 Section 6024
Every 200 Hours	Check and adjust valve clearance.	Section 2052
Twice a Year	Lubricate shaft spline on two hydrostatic motors.	Section 6033

<https://www.ebooklibonline.com>

Hello dear friend!

Thank you very much for reading.

Enter the link into your browser.

The full manual is available for immediate download.

<https://www.ebooklibonline.com>

INTERVAL	SERVICE	INSTRUCTIONS
Yearly	Change hydraulic oil. Clean hydraulic reservoir breathers. Tune up engine. Clean machine thoroughly. Clean and repack wheel bearings.	Section 4011 Section 2052 Section 6023
As Required	Replace fuel line filter Clean engine cooling fins. Replace air cleaner element. Drain sediment from carburetor bowl. Replace hydraulic oil filter. Check operation of steering controls, adjust as required. Clean drive chains with stiff brush and lubricate with SAE 30 engine oil.	Section 2052 Section 4011 Section 6034 Section 6023

FLUIDS AND LUBRICANTS CHART

COMPONENT	CAPACITY		SPECIFICATIONS
	U.S.	Metric	
Fuel tank Prior to S/N 9826660 S/N 9826660 and after	9 gallons 8.5 gallons	34 liters 31.7 liters	Use leaded, low lead or non-leaded regular gasoline. (Non-leaded or low lead gasoline must have an octane rating of 90 or higher.)
Engine crankcase	52 ounces or 1.6 quarts	1,5 liters	Use engine oil with classification SE, SC, or SD (MS). Above 32° F. - SAE 30 Below 32° F. - SAE 10W All temperatures - SAE5W-30
Equipment/transmission hydraulic system total system reservoir refill with filter change reservoir refill without filter change	7 gallons 15 quarts 14 quarts	25 liters 14,2 liters 13,2 liters	Engine oil classification SE or SD (MS) SAE 10W-40 NOTE: SAE 5W-20W oil can be used at 32° F and below if hard starting is a problem.
Battery	As required		Add colorless, odorless drinking water.
Grease fittings	As required		Above 32° F. Multipurpose or No. 2 lithium-soap base grease. Below 32° F. Multipurpose or No. 1 lithium-soap base grease.
Hydrostatic pump and motor shaft spline	As required		Molykote, Type G grease Case part number D58702 2 ounce (59 cm ³) tube









Section 1051

TORQUE CHART







U.S. AND METRIC TORQUE SPECIFICATIONS

Torque values for all situations unless special torque is specified.

Grade 5 Bolts, Nuts, Studs (Dry)

Thread Size	Torque			Thread Size	Torque	
	ft. lbs.	m-kg			ft. lbs.	m-kg
1/4" - 20 NC	5-10	0,7-1,4		3/4" - 10 NC	235-285	32-39
1/4" - 28 NF	10-15	1,4-2,1		3/4" - 16 NF	270-330	37-46
5/16" - 18 NC	15-20	2,1-2,8		7/8" - 9 NC	360-440	50-61
5/16" - 24 NF	15-20	2,1-2,8		7/8" - 14 NF	395-490	55-68
3/8" - 16 NC	25-35	3,5-4,8		1" - 8 NC	520-640	72-88
3/8" - 24 NF	30-40	4,1-5,5		1" - 12 NF	575-705	79-97
7/16" - 14 NC	45-55	6,2-7,6		1-1/8" - 7 NC	720-820	99-113
7/16" - 20 NF	50-60	6,9-8,3		1-1/8" - 12 NF	790-970	109-134
1/2" - 13 NC	65-85	9,0-12,0		1-1/4" - 7 NC	1010-1240	139-171
1/2" - 20 NF	80-100	11-14		1-1/4" - 12 NF	1115-1365	154-188
9/16" - 12 NC	100-120	14-17		1-3/8" - 6 NC	1315-1610	181-222
9/16" - 18 NF	110-130	15-18		1-3/8" - 12 NF	1510-1850	208-255
5/8" - 11 NC	135-165	19-23		1-1/2" - 6 NC	1745-2135	241-295
5/8" - 18 NF	160-200	22-28		1-1/2" - 12 NF	1880-2420	259-334

Grade 8 Bolts, Nuts, Studs (Dry)

Thread Size	Torque			Thread Size	Torque	
	ft. lbs.	m-kg			ft. lbs.	m-kg
1/4" - 20 NC	10-15	1,4-2,1		3/4" - 10 NC	340-420	47-58
1/4" - 28 NF	15-20	2,1-2,8		3/4" - 16 NF	380-460	52-63
5/16" - 18 NC	20-30	2,8-4,1		7/8" - 9 NC	540-660	75-91
5/16" - 24 NF	25-30	3,5-4,1		7/8" - 14 NF	595-725	82-100
3/8" - 16 NC	40-50	5,5-6,9		1" - 8 NC	810-990	112-137
3/8" - 24 NF	45-55	6,2-7,6		1" - 12 NF	900-1100	124-152
7/16" - 14 NC	60-80	8,3-11,0		1-1/8" - 7 NC	1150-1400	159-193
7/16" - 20 NF	70-90	9,7-12,0		1-1/8" - 12 NF	1295-1585	179-219
1/2" - 13 NC	100-120	14-17		1-1/4" - 7 NC	1640-2000	226-276
1/2" - 20 NF	110-130	15-18		1-1/4" - 12 NF	1800-2200	248-304
9/16" - 12 NC	135-165	19-23		1-3/8" - 6 NC	2140-2620	295-362
9/16" - 18 NF	155-190	21-26		1-3/8" - 12 NF	2450-3000	338-414
5/8" - 11 NC	200-240	28-33		1-1/2" - 6 NC	2845-3475	393-480
5/8" - 18 NF	215-265	30-37		1-1/2" - 12 NF	3200-3900	442-538

Hydraulic Fittings (Steel)

Dash Size	Tube O.D.	Thread Size	37° Flare Female Swivel Torque		Straight Thread O-Ring Torque	
			ft. lbs.	m-kg	ft. lbs.	m-kg
4	1/4"	7/16" - 20	6-12	0,8-1,7	12-19	1,7-2,6
5	5/16"	1/2" - 20	8-16	1,1-2,2	16-25	2,2-3,5
6	3/8"	9/16" - 18	10-25	1,4-3,5	25-40	3,5-5,5
8	1/2"	3/4" - 16	15-42	2,1-5,8	42-67	5,8-9,2
10	5/8"	7/8" - 14	25-58	3,5-8,0	58-92	8,0-12,7
12	3/4"	1-1/16" - 12	40-80	5,5-11,0	80-128	11-18
14	7/8"	1-3/16" - 12	60-100	8,3-14,0	100-160	14-22
16	1"	1-5/16" - 12	75-117	10-16	117-187	16-26
20	1-1/4"	1-5/8" - 12	125-165	17-23	165-264	23-36
24	1-1/2"	1-7/8" - 12	210-250	29-35	250-400	35-55

Section 2050

**ENGINE REMOVAL, INSTALLATION,
AND DRIVE BELTS**

ENGINE REMOVAL

1. Remove seat/heat shield assembly. Then loosen the hydrostatic pump adapter plate mounting bolts and equipment pump mounting bolts and remove belts from pump sheaves.
2. Swing oil cooler out of way. Remove ground cable from engine (below starter) and tape cable end to prevent accidental grounding.
3. Remove cable from starter and disconnect harness at plug from engine.
4. Disconnect choke and throttle cables at carburetor and position out of way.
5. Disconnect fuel line at fuel pump, remove hose from supporting clamp and secure loose end of hose above fuel tank to prevent siphoning fuel tank.
6. Remove four engine mounting bolts and remove engine.

NOTE: All late production bolts have been installed with Loctite.

ENGINE INSTALLATION

1. If a new engine or a new crankshaft was installed, refer to Section 6021 clutch installation.
2. If original engine is being installed and clutch was removed, align clutch set screws with drill spots on crankshaft and torque set screws to 11-13 foot-pounds.
3. Place drive belts on clutch and set engine on mounting pads. As the engine is slid into place, install belts on pump sheaves.
4. Position engine in original position as close as possible. Coat engine mounting bolt threads with 242 (blue) Loctite and install bolts. When clutch is parallel to and about 1/8" from pump mounting plate, torque mounting bolts to 40 foot-pounds.
5. Connect fuel line to fuel pump. Install fuel line support clamp.
6. Connect choke and throttle cables to carburetor.
7. Connect wiring harness and starter cable to starter.
8. Connect ground cable to engine below starter.
9. Tighten drive belts as instructed in this section.
10. If crankcase was drained, fill with oil specified in Section 1050.
11. Swing oil cooler into place and secure with nuts and bolts.
12. Install seat/heat shield assembly.

NOTE: Early production machines used lock washers with the engine mounting bolts. Discard lock washers and replace with hardened flat washers. Refer to parts catalog.

DRIVE BELTS

Vickers Hydrostatic Pump and Equipment Pump Belts

Due to the time required to replace a belt, careful consideration should be given to replace all belts at the same time.

Removal

1. Remove seat/heat shield assembly. Then

loosen the hydrostatic pump adapter plate mounting bolts and equipment pump mounting bolts and remove belts from pump sheaves.

2. Swing oil cooler out of way. Remove ground cable from engine (below starter) and tape end of cable to prevent accidental grounding.



Suggest:

For more complete manuals. Please go to the home page.

<https://www.ebooklibonline.com>

If the above button click is invalid. Please download this document first, and then click the above link to download the complete manual.

Thank you so much for reading

3. Remove cable from starter and disconnect wiring harness at plug from engine.
4. Disconnect choke and throttle cables at carburetor. Slide engine to rear and remove belts.

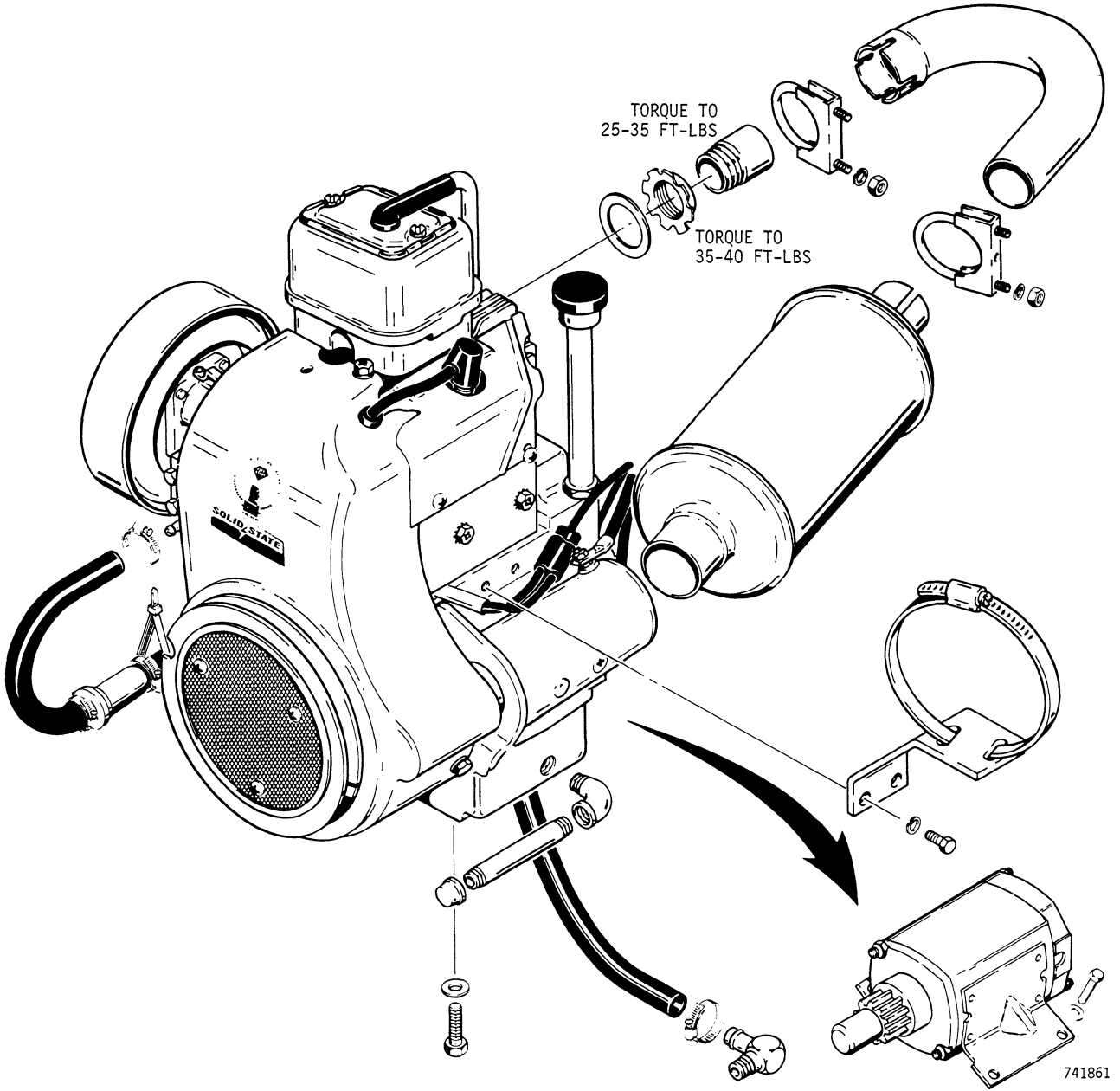

Figure 1 - Engine

Installation

1. Place belts on clutch and slide engine into place. As the engine is slid into place, install belts on pump sheaves.
2. Position engine in original position as close as possible and install mounting bolts. When clutch is parallel to and 1/8" from pump mounting plate, tighten engine mounting bolts.
3. Connect starter cable to starter and ground cable to engine.
4. Connect choke and throttle cables to carburetor.
5. Adjust belts as instructed under Adjustment.
6. Install seat/heat shield assembly. Swing oil cooler into place and secure with nuts and bolts.

Adjustment

Hydrostatic Pump Belt

1. Remove seat/heat shield assembly.
2. Loosen pump adapter plate mounting bolts and pry against pump to tighten belt.
3. Check belt tension using a pound spring scale midway between the clutch and pump sheaves.
 - a. If hydrostatic pumps are staggered (Vickers), belt deflection should be 1/8" at 7-8 pounds.
 - b. If hydrostatic pumps are even (Sundstrand), belt deflection should be .10" (slightly less than 1/8") at 5 - 7 pounds.
4. Make sure adapter plate bolts are tight and install seat/heat shield assembly.

Equipment Pump Belt

1. Loosen pump mounting bolts and pry against pump to tighten belt.
2. Check belt tension using a pound spring scale. Belt deflection should be 1/8" with a scale reading of 3-4 pounds.
3. Make sure pump mounting bolts are tight.

Sundstrand Hydrostatic Pump and Equipment Pump Belts

All belts can be removed without removing the engine. Both hydrostatic pump belts must be removed if the equipment pump belt is to be removed. If the left hydrostatic pump is to be removed, the right pump belt must be removed also.

Removal

1. Remove seat/heat shield assembly and side screen(s).
2. Loosen pump adapter plate mounting bolts as required and remove belt from pump sheave(s).
3. Work belt(s) to front of clutch sheave and remove belt(s).

Installation

1. If all belts were removed, install the equipment pump belt first.
2. Install belt(s) from front of clutch and place in proper groove in clutch sheave, Figure 3.
3. Place belt(s) in pump sheave(s) and adjust belt tension as instructed under Adjustment.
4. Install side screen(s) and seat/heat shield assembly.

<https://www.ebooklibonline.com>

Hello dear friend!

Thank you very much for reading.

Enter the link into your browser.

The full manual is available for immediate download.

<https://www.ebooklibonline.com>