

1500 SERIES UNI-LOADERS

TABLE OF CONTENTS

SECTION	SECTION NO.	FORM NO.
GENERAL		
Maintenance and Lubrication	13	9-71535
ENGINE		
Air Cleaner	24	9-71535
<p>NOTE: Manuals for the Wisconsin engines are supplied by the Wisconsin Motor Division of the Continental Motors Corporation.</p>		
FUEL SYSTEMS		
Electric Fuel Pump	34	9-71535
<p>NOTE: For carburetor information, refer to the service manual for the Wisconsin engine.</p>		
LP Gas Fuel System	37	9-71535
HYDRAULICS		
Hydraulic System	41	9-71535
Hydraulic System	41, Supp. 1	9-71536
<p>NOTE: Supplement 1 for Section 41 incorporates changes and improvements made to the machine after printing of Section 41. Following are the major areas of change:</p> <ol style="list-style-type: none"> a. Updated pressure checks and troubleshooting procedures. b. Updated specifications and hydraulic diagrams. c. 3-spool control valve with new plunger-type relief valve. d. Variable speed control valve with new thermal relief valve. e. New TRW hydraulic pump. 		
POWER TRAIN		
Power Train	61	9-71536
BRAKES		
Brakes	72	9-72095
ELECTRICAL		
Electrical System	82	9-71535
MOUNTED EQUIPMENT		
Loader	92	9-71535
Loader	92, Supp. 1	9-71536
<p>NOTE: Supplement 1 for Section 92 incorporates changes and improvements made to the machine after printing of Section 92.</p>		
Rollover Protection Structure	9019	9-71535

Section 13

MAINTENANCE AND LUBRICATION

MAINTENANCE CHART

Model 1526

INTERVAL	SERVICE	FLUID/LUBRICANT	INSTRUCTIONS
Run-In After First 20 Hours	Change engine oil and clean engine oil filter. Check valve clearance.	See chart, page 4.	See engine manual. See engine manual.
Run-In After First 60 Hours	Change engine oil and clean engine oil filter.	See chart, page 4.	See engine manual.
Every 10 Hours Or Daily	Check engine oil level.		See engine manual.
Every 120 Hours	Change engine oil and clean engine oil filter. Check valve clearance.	See chart, page 4.	See engine manual.
Every 240 Hours	Check generator drive belt tension. Clean fuel filter.		See engine manual. See engine manual.
Every 600 Hours	Clean and test fuel injection. Lubricate starter motor. Check generator operation.	Engine oil.	See engine manual. See engine manual.
Every 1000 Hours	Clean starter motor. Lubricate flywheel ring gear.		See engine manual. See engine manual.
As Required	Clean engine cooling fins.		See engine manual.

Model 1530 & 1537

Every 10 Hours Or Daily	Check engine oil level.		See engine manual.
Every 50 Hours	Change engine oil. Lubricate distributor.	See chart, page 4. 3 to 5 drops engine oil.	See engine manual.
Every 100 Hours	Change engine oil filter.		See engine manual.
As Required	Clean fuel sediment bowl. Clean engine cooling fins.		See engine manual.
At Engine Or Starter Overhaul	Lubricate starter.	#2 lithium-soap base grease.	See engine manual.

<https://www.ebooklibonline.com>

Hello dear friend!

Thank you very much for reading.

Enter the link into your browser.

The full manual is available for immediate download.

<https://www.ebooklibonline.com>

Inspect filter after it is clean and dry. Place a light inside filter and inspect for holes, tears, and dented or bent metal covering. If metal covering is dented or bent, inspect filter paper for holes or rub spots in that area. If holes or rub spots are noted, discard filter and install new filter element.

NOTE: Inspect new filter element for defects in the same manner. Do not accept a defective filter.

The filter must be replaced after it has been cleaned six times or once a year, whichever ever occurs first.

OPTIONAL AIR CLEANER

Filter service consists of replacing the filter element when the red band on the restriction indicator remains in view. In

addition to replacing the filter element, wipe out the filter housing with a damp, lint free cloth and clean the pre-cleaner.

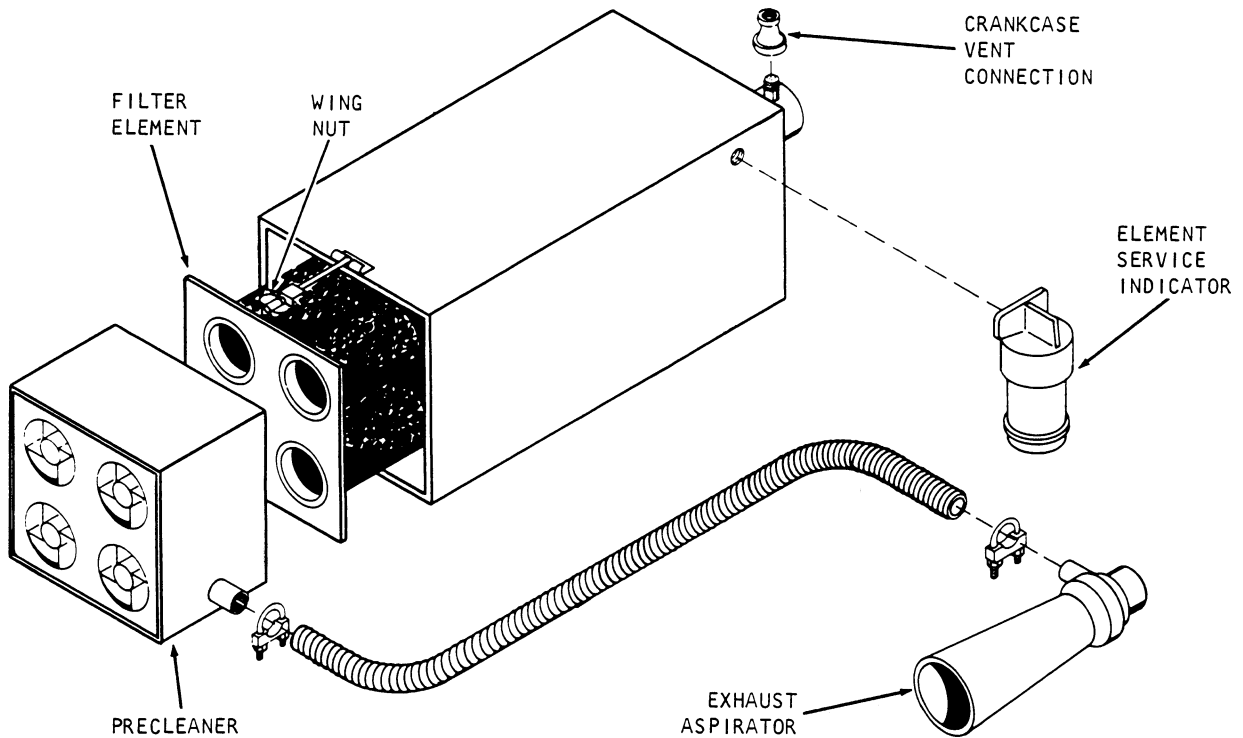

Figure 3 - Exploded View of Air Cleaner

Section 24

AIR CLEANER

STANDARD AIR CLEANER

Service Interval

The service interval is self determined, taking into consideration working conditions. It is only natural that the filter element be serviced more often when the machine is operated in a dusty or sandy atmosphere. In addition to element service, the dust cup should be cleaned daily or more often as conditions warrant.

Filter Element Service

The preferred method of cleaning the filter is by washing. Washing the filter results in restoring the filter to an almost new condition and longer intervals between servicing. It is recommended that a spare filter be available to allow sufficient drying time for the serviced filter and to reduce machine downtime.

Wash the filter in Case Filter Element Cleaner (Part No. A40910) according to instructions on container. Rinse thoroughly. Do not use water pressure over 40 psi at

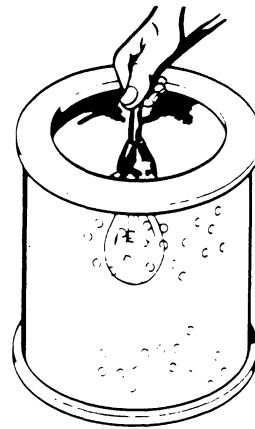

Figure 1 - Inspecting The Element

nozzle. Set filter aside to dry. Do not use compressed air to dry.

Use of compressed air to clean the filter is permissible but not recommended as it does not remove carbon and soot. When using compressed air, use no more than 100 psi at nozzle and keep nozzle a reasonable distance away from filter.

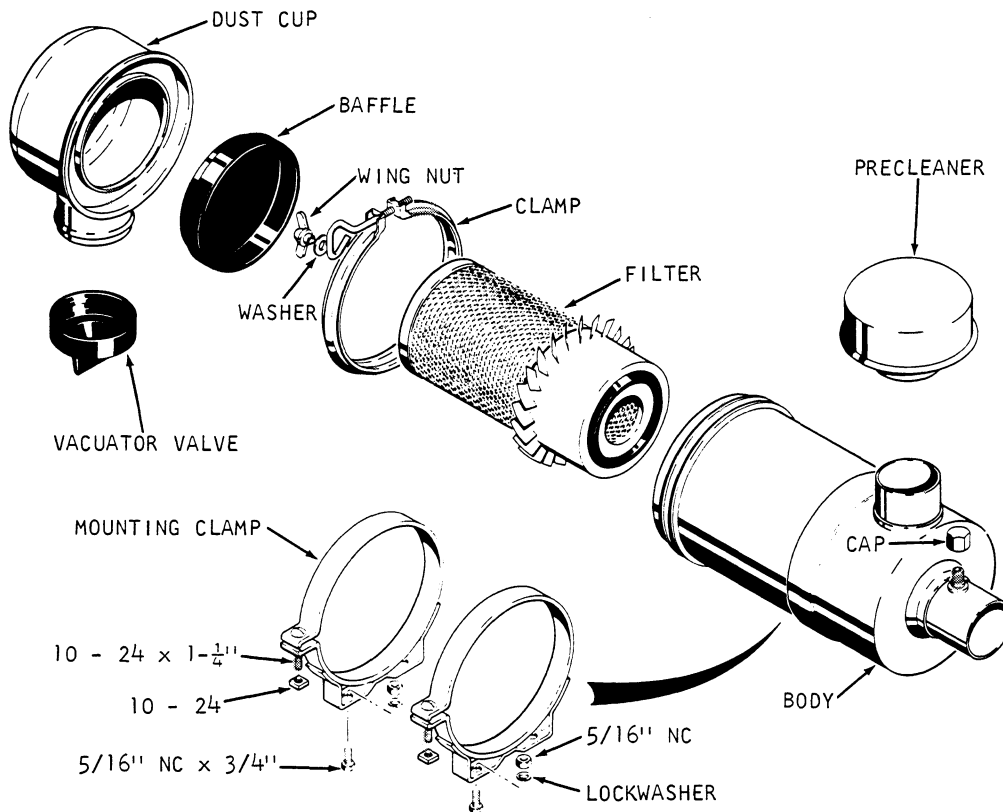

Figure 2 - Exploded View of Air Cleaner

All Models

INTERVAL	SERVICE	FLUID/LUBRICANT	INSTRUCTIONS
Run-In Every 2 Hours	Check wheel bolt torque until stable. (85-100 ft. lbs.)		
Run-In After First 15 Hours	Replace hydraulic oil filter.		Section 41.
Every 10 Hours Or Daily	Grease the loader pivot points. Clean the air cleaner dust cup.	See chart, page 4.	
Every 20 Hours Hours	Grease variable speed pulleys. (Three strokes each fitting).	See chart, page 4.	
Every 25 Hours Severe Service	Check and adjust drive chains.		Section 61.
Every 50 Hours Normal Service	Check and adjust drive chains.		Section 61.
Every 60 Hours	Check battery electrolyte level. Check hydraulic oil level. Check tire pressure.	Distilled water.	Section 82. Section 41.
Every 120 Hours	Grease drive shaft universals. Check gear box oil level.	See chart, page 4.	Section 61.
Every 500 Hours	Replace or clean electric fuel pump filter. Change hydraulic oil. Replace hydraulic oil filter.	Case TCH Fluid.	Section 34. Section 41. Section 41.
Every 1000 Hours	Clean hydraulic reservoir breather and filler cap. Drain water from fuel tanks.		Section 41.
Every 2000 Hours Or Yearly	Change gear box oil. Replace fuel filter element (LP gas machines only).	See chart, page 4.	Section 61.
As Required	Clean or replace air cleaner element. Replace hydraulic filter. Check wheel bolt torque (85-100 ft. lbs.) Adjust clutches when lever travel exceeds 6" from neutral.		Section 24. Section 41. Section 61.

LUBRICANT CHART

ITEM	CAPACITIES		RECOMMENDATIONS
	U. S.	METRIC	
Model 1526 Engine crankcase	6-1/4 qts.	6 liters	Use engine oil meeting the following specifications: (Normal conditions) CA Commercial Class A (DG) (MIL-L-2104A, Supp. 1) (Extreme conditions) CB Commercial Class B Above 68° F. SAE 30 (20° C) 68° F. to -14° F. . . . SAE 20/20W (20° C to -10° C) NOTE: For continuous full load duty, use SAE 30 oil.
Model 1530 Engine crankcase Without filter change	3-1/2 qts.	3,3 liters	Use engine oil meeting the following specifications: SD Service Class D (MS)
With filter change	4 qts.	3,8 liters	120° F. to 40° F. SAE 30 (49° C to 4° C)
Model 1537 Engine crankcase Without filter change	4-1/2 qts.	4,3 liters	40° F. to 15° F. SAE 20-20W (4° C to -9° C)
With filter change	5 qts.	4,7 liters	15° F. to 0° F. SAE 10W (-9° C to -18° C) Below 0° F. SAE 5W - 20W (-18° C)
Gear box (all machines)	1-1/2 pts.	0,7 liters	Multipurpose gear lubricant SAE 90 EP--Case Part No. B53983 API-GL-4 with low foaming additive.
Hydraulic reservoir refill capacity	14 gal.	53 liters	Case TCH fluid.
Hydraulic system capacity (approx.)	19 gal.	72 liters	Case TCH fluid.
Fuel tanks (combined) 1526 & 1537 1530	17 gal. 12 gal.	64 liters 45 liters	
Grease fittings	As required.		Above 32° F. (0° C) use Multipurpose or No. 2 lithium-soap base grease. Below 32° F. (0° C) use Multipurpose or No. 1 lithium-soap base grease.

NOTE: Automatic transmission oil Type A Suffix A may be used as an alternate oil for Case TCH Fluid.

Section 34

ELECTRIC FUEL PUMP



Suggest:

For more complete manuals. Please go to the home page.

<https://www.ebooklibonline.com>

If the above button click is invalid. Please download this document first, and then click the above link to download the complete manual.

Thank you so much for reading

ELECTRIC FUEL PUMP

Description And Operation

NOTE: Servicing and parts replacement is limited to the parts shown in Figure 1. If an electrical component fails, the pump must be replaced.

The electric fuel pump is designed with a solenoid which, when energized, causes the movement of a hollow plunger in a cylindrical bore. The plunger stroke is controlled by a set of interrupter type contact points in the pump electrical circuit. The contact points function in a sealed section containing an inert gas for long point life.

Upon energization of the solenoid, the plunger is forced down in the cylinder against the plunger spring which is seated on a closed check valve in the bottom of the bore. A check valve in the plunger opens permitting passage of the trapped fuel through the plunger.

On the opening of the contacts the solenoid is de-energized; the plunger spring returns the plunger to the top of the bore at a fixed rate to provide the required pressure. During the upward movement of the plunger, the check valve in the plunger is closed to move the fuel ahead of it into the fuel system and the check valve in the bottom of the bore is open to permit passage of fuel into the cylinder for the next cycle.

A pulsation dampener in the top of the pump provides steady operation and even pressure. The pump also incorporates a pressure relief system to assure an immediate return to zero fuel pressure when the ignition is turned off.

The filter system is contained in the lower portion of the pump and consists of a filter and magnet.

Removal

1. Disconnect the inlet and outlet fuel lines at the fuel pump. Secure inlet line as high as possible to prevent fuel tank drainage.
2. Disconnect the wire at the connector in the fuel pump lead.

3. Remove the fuel pump mounting nuts and lockwashers. Remove fuel pump.

Disassembly

Refer to Figure 1.

1. Use a wrench to turn bottom cover from bayonet pins. Twist cover by hand to remove from pump body.
2. Remove filter, magnet and cover gasket.
3. Remove retainer spring using a thin nose pliers to spread and remove the ends of the retainer from plunger tube.
4. Remove washer, o-ring, cup valve, plunger spring and plunger.

Inspection

1. Wash the filter in cleaning solvent and blow out dirt and cleaning solvent with compressed air. Check cover gasket and replace if deteriorated. Clean the cover.
2. Clean the remainder of the removed parts in cleaning solvent. If the plunger does not wash clean or if there are any rough spots, gently clean the surface with crocus cloth. Shake plunger and listen for click to indicate valve action. If valve is not free, replace plunger assembly.

CAUTION: The buffer spring and valve must not be removed from plunger.

3. Slosh the pump assembly in cleaning solvent. Blow out the tube with compressed air. To do a complete job, swab the inside of the tube with a cloth wrapped around a stick.

CAUTION: Do not tamper with seal at center of mounting bracket at side of pump as it retains the dry gas which surrounds the electrical system in the upper portion of the pump.

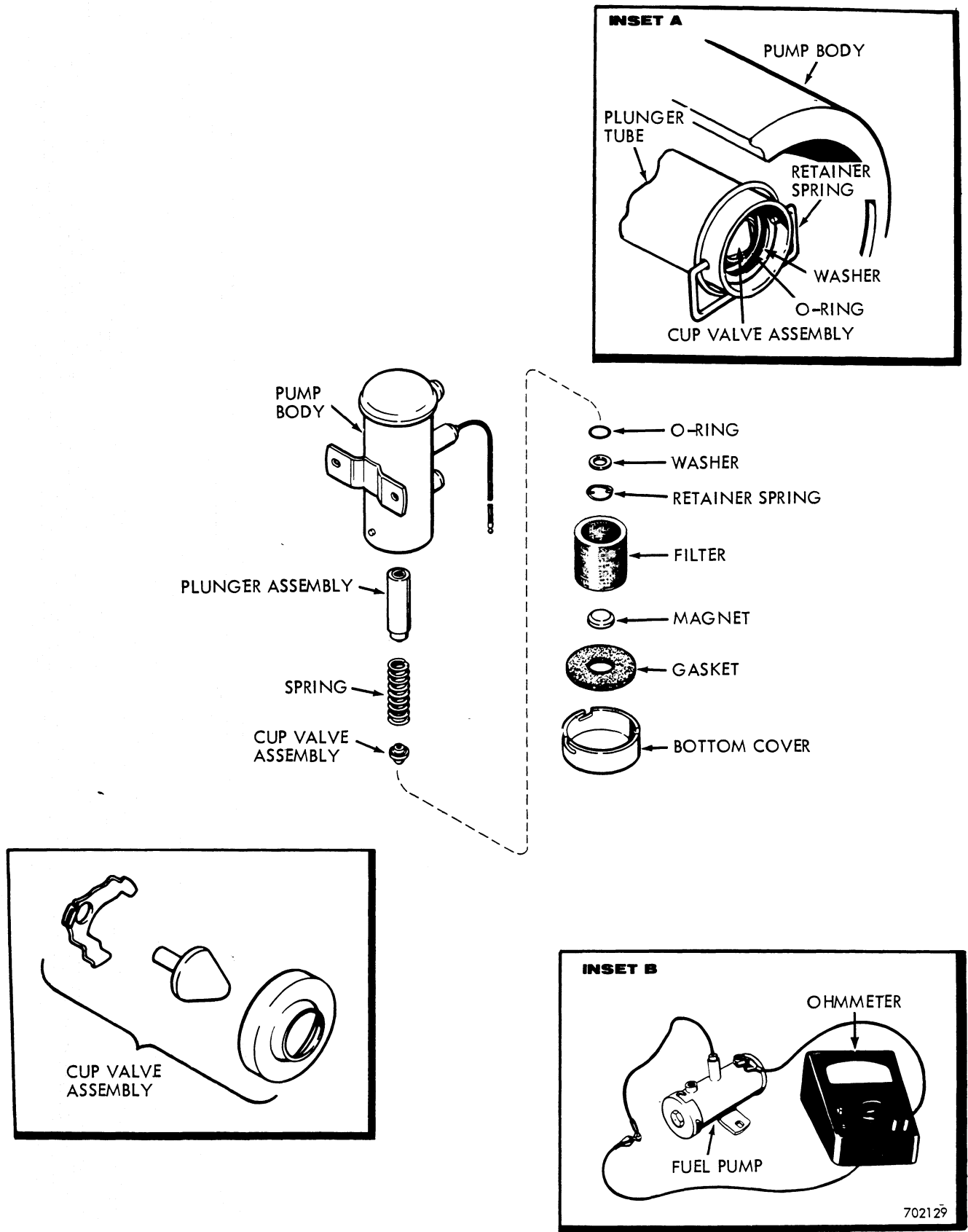

Figure 1 - Exploded View of Electric Fuel Pump

<https://www.ebooklibonline.com>

Hello dear friend!

Thank you very much for reading.

Enter the link into your browser.

The full manual is available for immediate download.

<https://www.ebooklibonline.com>