

**422/M2
422T/M2
Engines**

Service Manual

Bur 6-79550NA



CASE ENGINES

422/M2 422T/M2

SERVICE MANUAL

Part Number: 6-79550NA

TABLE OF CONTENTS

GENERAL INFORMATION	3
General Description	3
Engine Component Descriptions	3
Engine Model and Serial Number Location	4
Turbocharger Lubrication	4
Safety Precautions	5
422/M2 GENERAL ENGINE SPECIFICATIONS	6
422T/M2 GENERAL ENGINE SPECIFICATIONS	8
TROUBLESHOOTING	10
ENGINE SERVICE SPECIFICATIONS	17
ENGINE TORQUE SPECIFICATIONS	22
SPECIAL TOOLS	23
ENGINE DISASSEMBLY	24
Alternator	24
Remove Cooling Fan and Pulley	24
Fuel Injection Pipe	24
Injector Assembly	24
Water Pump Assembly	25
Exhaust Manifold	25
External Oil Pipe (422/M2)	25
External Oil Pipe (422T/M2)	26
Rocker Assembly	26
ENGINE COMPONENT	30
Disassembly and Assembly	30
Rocker Assembly	30
Cylinder Head Assembly	30
Valve Guide and Valve Stem	31
Cylinder Block	33
Piston and Piston Rings	34
Engine Governor Assembly	46
Governor Operation	47
ENGINE REASSEMBLY	49
How To Operate the Engine After Overhaul	58
Fuel Injection Nozzle and Holder	58
TURBOCHARGER - 422T/M2 ENGINE	63
Turbocharger Troubleshooting	63
MISCELLANEOUS ENGINE ELECTRICAL	69
Glow Plug	69

<https://www.ebooklibonline.com>

Hello dear friend!

Thank you very much for reading.

Enter the link into your browser.

The full manual is available for immediate download.

<https://www.ebooklibonline.com>

GENERAL INFORMATION

General Description

The 422/M2, 422T/M2 Series are four stroke, liquid-cooled, compression ignition engines, designed for durability, low weight and compactness. The engines are IDI (In Direct Injection). The linerless cylinder block, three-piece helical gear train, and flange-mounted fuel injection pump on the engine cam, reduce frictional power loss and engine weight. The special direct-injection or swirl chamber, along with the small bore multi-cylinder design, offers good fuel consumption, low noise, and excellent start-ability.

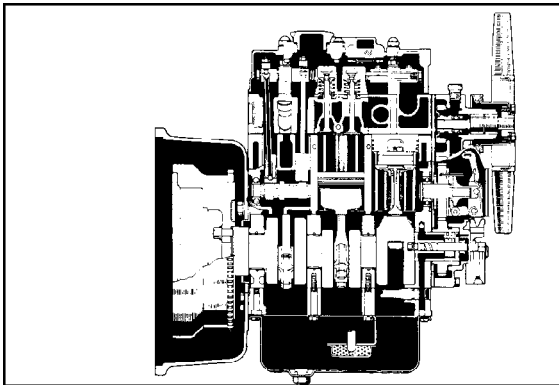

BS05B258

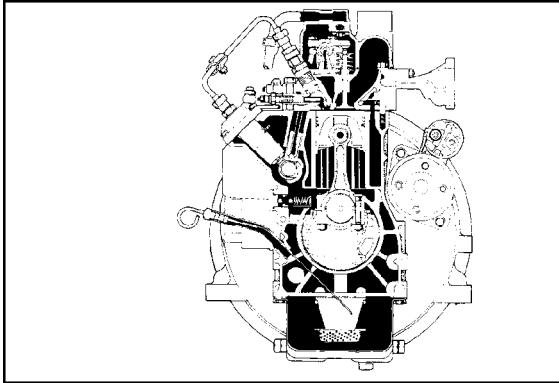

BS05B259

Engine Component Descriptions

Cylinder Block

The cylinder block is made from high-grade cast iron with copper and chrome additives and is integral with the crankcase. The crankcase features five main bearings of the tunnel block design, with crankcase walls extending well below the crankshaft centerline for strength and rigidity. The cylinder's bores are plateau honed for oil retention and extended ring life. The non-machined surfaces are sealed to ensure cleanliness.

Crankshaft

The crankshaft is a chrome-molybdenum steel forging, full machined, static, and dynamically balanced with integral counterweights. All bearing surfaces are induction hardened. The axial location is by thrust washers at the number five main bearing. The five main journals run in replaceable steel-backed cast copper/lead alloy bearings. The front of the crankshaft is keyed.

Pistons and Connecting Rods

Pistons are cast from high silicon aluminum alloy and are heat-treated for low weight with high strength and good thermal conductivity. The piston is fitted with three rings; two cast iron, chrome-faced compression rings and one steel, chrome-faced controlled oil ring. The fully floating gudgeon pin (wrist pin) is made of chrome molybdenum steel alloy hardened by carbonizing and retained by the conventional retaining ring method. The connecting rods are machined from high-strength forged steel. The big end bearings are renewable steel-backed, copper/lead alloy overlay with tin plating. The small end bearings are a press fit plain bushing of tin-backed lead-bronze.

Camshaft

The camshaft is made of forged steel and is induction hardened. Three or four additional lobes at the front operate the fuel injection pump. At the rear, a fuel lift pump eccentric is machined. The camshaft is supported by roller and needle bearings and lubricated by splash feed. The nose of the camshaft supports the cam gear, governor weight cage, and governor slider assembly.

Cylinder Head

The cylinder head is made of high grade copper chrome cast iron, and incorporates replaceable heat-resistant alloy steel valve seats. Inlet and exhaust valves are made of high grade heat resistant alloy steel with tuft-ridged stems and induction hardened heads. Each stem is fitted with a chrome molybdenum steel cap for long life.

The valves are operated by cold drawn seamless tube push rods with hardened steel ball and forged cup ends. Flat-based tappets are made from case carburized chrome molybdenum steel operating in machined bores in the cylinder block. The rocker shaft is an induction hardened hollow steel tube. Valve clearances are adjusted by hardened ball-ended screws and locknuts.

Rocker Cover and Inlet Manifold

The cover is made of cast aluminum with an air intake, oil filler, and crankcase breather. It is located in position by rocker pillar studs and secured by cap nuts.

Gear Train

The gear train consists of three helical gears - the crankshaft gear located by a woodruff key, the idler gear houses the lube oil pump, and the cam gear incorporates the governor weight cage.

Fuel System

A flanged-mounted, Bosch-type fuel injection pump is mounted in the cylinder block and operated by lobes machined on the engine cam.

Lubricating System

A trochoid lobe oil pump located in the center of the idler gear sends lubricating oil to the main oil galley via a relief valve through a spin-on bypass oil filter to the main oil gallery. The rockers are pressure fed via an externally mounted oil pipe from the main oil gallery to the cylinder head.

Cooling System

A belt-driven centrifugal water pump circulates coolant via the internal water passages. The coolant is radiator cooled and temperature controlled by a conventional thermostat.

Engine Model and Serial Number Location

The engine model number is located on the right side of the engine block at 1. The engine serial number is located at 2.

Throughout this manual, whenever the left- or right-hand side of the engine is referred to, it is that side of the engine when viewed from the flywheel end.

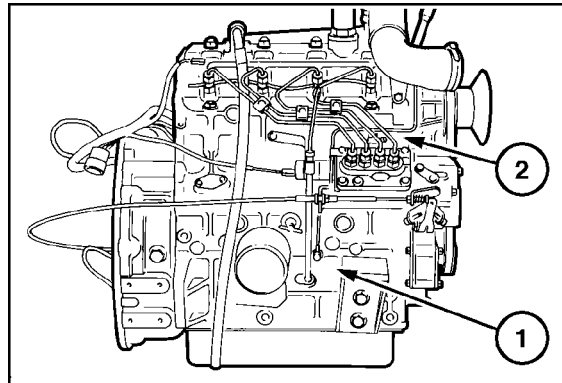

BS05B260

Turbocharger Lubrication

The turbocharger used on the 422T/M2 diesel engine may not receive adequate lubrication on cool/cold weather (below 5°C, 40°F) start-up, leading to turbocharger bearing failure.

The following procedure must be used to ensure adequate lubrication oil is supplied to the turbocharger bearings before high-speed engine operation:

1. Set the engine throttle at 1/3 speed.
2. Turn the ignition switch and allow the automatic glow plug timer to preheat the engine until the EIC "beep" is heard.
3. Start the engine, but **DO NOT OPERATE ABOVE 1,500 RPM** for three minutes to allow for adequate oil flow at the turbocharger.

After full load operation, allow the engine to run at low idle for one minute before engine shutdown.

Safety Precautions

The following safety precautions are very important.

IMPORTANT: *Do not change the specification of the engine.*

Do not smoke when you put fuel in the tank.

Clean away any fuel which has spilled and move material which has fuel contamination to a safe place.

Do not put fuel in the tank during engine operation.

Never clean, lubricate or adjust the engine during operation unless otherwise specified in this manual. Use extreme caution when working around moving parts to prevent injury.

Do not make any adjustments you do not understand.

Ensure the engine is not in a position to cause a concentration of toxic emissions.

Persons in the area must be kept clear during engine and equipment or vehicle operation.

Do not permit loose clothing or long hair near parts which move.

Keep away from parts which turn during operation. Note that fans cannot be seen clearly while the engine is running.

Do not run the engine with any safety guards removed.

Do not remove the radiator cap while the engine is hot and the coolant is under pressure, as dangerous hot coolant can be discharged.

Do not use salt water in the fresh water cooling system or any other coolant which can cause corrosion.

Keep sparks or fire away from batteries (especially while charging) or combustion can occur. The battery fluid can burn and is also dangerous to the skin and especially the eyes.

Disconnect the battery terminals before you make a repair to the electrical system.

Only one person must be in control of the engine.

Ensure the engine is only operated from the control panel or operator's position.

If your skin comes into contact with high pressure fuel, get medical assistance immediately.

Diesel fuel and used engine oils can cause skin damage to some persons. Use protection on the hands (gloves or special skin protection solutions).

Do not move equipment unless the brakes are in good condition.

Be sure that the transmission drive control is in "Neutral" position before the engine is started.

IMPORTANT: *Do not use ether to start these engines.*

422/M2 GENERAL ENGINE SPECIFICATIONS

Engine Model	422/M2
Type	Vertical in-line 4-stroke - naturally aspirated
Basic Thread and Size	
Bore	84 mm (3.31 inches)
Stroke	100 mm (3.94 inches)
Combustion System	IDI (Indirect Injection/Special Swirl)
Compression Ratio	22.4:1
Swept Volume Liter (inch ³)	2216 L (135.3 inch ³)
Firing Order	1-3-4-2
Rotation	Counterclockwise viewed from flywheel
Low Idle	1050 ± 50 RPM
High Idle	3050 ± 50 RPM
Injection Pump	Flange-Mounted, Bosch-type plunger and barrel
Injectors	Bosch-type throttle
Injector Setting	147 - 157 Kilograms sq. cm kgf/cm ² (2132 - 2277 Pounds per sq. inch PSI)
Turbo	NO
Governor	Mechanical all speed
Cooling System	Liquid with water pump and radiator
Industrial Cooling System Capacity (less radiator)	3.5 Litres
Thermostat Operating	
Temperature degrees	71°/82° C (160°/180° F)
Oil Pressure Relief	3.6 - 4.6 kgf/cm ² (51 - 65 PSI)
Oil Pressure Switch	4.3 PSI
Electrical Starter	
Starter	12V
Alternator	12V
Weight, Bare Engine (Industrial)	205 kg (452 lbs)
Height	786 mm (30.9 inches)
Length	665 mm (26.2 inches)
Width	431 mm (17 inches)

Recommended Engine Fluids

Coolant Clean soft water. Maximum antifreeze concentration
50% (ethanediol base-ethylene glycol with corrosion inhibitor to
BS 6850:1985 or ASTM D3306-74 or AS 2108-1977)

Fuel Cetane number-45 minimum, Viscosity-2.5/4.5
centistokes at 40° C (104° F). Density-0.835/0.855
kg/liter, Sulfur -0.5% of mass maximum. Distillation
85% at 350° C (662° F). Aviation fuel JP4 is not
recommended; however, JP5 and JET-A are
acceptable, proving 5% spindle oil is added).

Lubricating

System Pressure feed with Trochoid pump

Oil Type API Service CH 4 SAE 10W-30
(SAE 5W30 for extended cold weather operation)

Engine Crankcase Capacity with Filter 8.7 L (9.2 US quarts)

Engine Crankcase Capacity Without Filter Change 8.5 L (9.0 US quarts)

422T/M2 GENERAL ENGINE SPECIFICATIONS

Engine Model	422T/M2
Type	Vertical in-line 4-stroke - Turbocharged
Basic Thread and Size	
Bore	84 mm (3.31 inches)
Stroke	100 mm (3.94 inches)
Combustion System	IDI (Indirect Injection/Special Swirl)
Compression Ratio	22.4:1
Swept Volume Liter (inch ³)	2216 L (135.3 inch ³)
Firing Order	1-3-4-2
Rotation	Counterclockwise viewed from flywheel
Low Idle	1050 ± 50 RPM
High Idle	3050 ± 50 RPM
Injection Pump	Flange-Mounted, Bosch-type plunger and barrel
Injectors	Bosch-type throttle
Injector Setting	147 - 157 Kilograms sq. cm kgf/cm ² (2132 - 2277 Pounds per sq. inch PSI)
Turbo	YES
Governor	Mechanical all speed
Cooling System	Liquid with water pump and radiator
Industrial Cooling System Capacity	
(less radiator)	3.9 Litres
Thermostat Operating	
Temperature degrees	71°/82° C (160°/180° F)
Oil Pressure Relief	3.5 - 4.5 kgf/cm ² (51 - 65 PSI)
Oil Pressure Switch	4.3 PSI
Electrical Starter	
Starter	12V
Alternator	12V
Weight, Bare Engine (Industrial)	212 kg (467 lbs)
Height	803 mm (31.6 inches)
Length	665 mm (26.2 inches)
Width	456 mm (18.0 inches)

Recommended Engine Fluids

Coolant Clean soft water. Maximum antifreeze concentration 50% (ethanediol base-ethylene glycol with corrosion inhibitor to BS 6850:1985 or ASTM D3306-74 or AS 2108-1977)

Fuel Cetane number-45 minimum, Viscosity-2.5/4.5 centistokes at 40° C (104° F). Density-0.835/0.855 kg/liter, Sulfur -0.5% of mass maximum. Distillation 85% at 350° C (662° F). Aviation fuel JP4 is not recommended; however, JP5 and JET-A are acceptable, providing 5% spindle oil is added).

Lubricating

System Pressure feed with Trochoid pump

Oil Type API Service CH 4 SAE 10W-30 (SAE 5W30 for extended cold weather operation)

Engine Crankcase Capacity with Filter 8.7 L (9.2 US quarts)

Engine Crankcase Capacity Without Filter Change 8.5 L (9.0 US quarts)

TROUBLESHOOTING

ENGINE WILL CRANK BUT DOES NOT START

CAUSE	CORRECTION
Faulty key switch	Correct the connection and/or replace switch
Fuel solenoid not operating	Check solenoid for battery voltage and correct
Insufficient charging or complete discharging of the battery	Charge or replace battery
Lack of fuel	Fill fuel tank
Air mixed in the fuel system	Bleed the air
Clogged fuel filter	Replace
Irregular and faulty fuel supply (electric fuel pump)	Check power supply; check fuse in fuse panel; check for corroded internal components (replace pump and in-line filter if corroded)
Irregular and faulty fuel supply (injection pump trouble)	Repair in an authorized service shop
Glow plug not heating	Failure of the glow plug; replace
Improper viscosity of the lubricating oil	Inspect and replace
Clogged air cleaner	Clean or replace
No Compression	Repair in a service shop

ENGINE WILL NOT CRANK OR START

CAUSE	CORRECTION
Faulty key switch	Correct the connection and/or replace switch
Insufficient charging or complete discharging of the battery	Charge or replace battery
Insufficient charging or complete discharging of the battery	Charge or replace battery

IRREGULAR RUNNING OF THE ENGINE

CAUSE	CORRECTION
Air mixed in the fuel system	Bleed the air from the system
Uneven fuel injection (faulty fuel injection pump)	Repair at authorized shop
Clogged fuel filter	Replace
Defective governor	Check and correct
Engine itself defective	Repair in a service shop

ENGINE STOPS DURING OPERATION

CAUSE	CORRECTION
Lack of fuel in the tank	Fill fuel tank and bleed air
Clogged fuel filter	Replace
Air mixed in the fuel system	Bleed the air
Faulty function of the engine	Repair in a service shop

OVERHEAT OF THE ENGINE

CAUSE	CORRECTION
Lack of cooling water	Supply water, inspect for leakage and correct
Loose or slipping fan belt	Remove oil, dust, etc. and tighten
Damaged fan belt	Replace
Clogged radiator	Flush the radiator
Clogged radiator fin	Clean
Dust or scale clogged in the cooling water passage	Flush the system
Faulty function of the thermostat	Inspect or replace thermostat
Lack of lubricating oil	Add oil
Overloading	Decrease the load

FAULTY CHARGING

CAUSE	CORRECTION
Loose fan belt	Correct belt tension
Faulty wiring	Inspect and correct
Faulty battery	Repair
Worn out alternator brush	Replace

STARTER MOTOR DOES NOT RUN

CAUSE	CORRECTION
Loose or disconnected wiring	Inspect and tighten
Low voltage of the battery	Charge the battery
Damaged started motor	Repair in a service shop

OIL PRESSURE LAMP NOT TURNED OFF

CAUSE	CORRECTION
Lack of engine oil	Fill oil to the specified level
Fault in the pressure switch	Replace the switch
Oil leakage from the lubricating system	Inspect and retighten
Clogged oil filter	Replace with new one

EXCESSIVE SMOKE/ENGINE MISS

CONDITION	CAUSE	CORRECTION
Good power, but misses or smokes at top engine speed	Top engine speed too high	Adjust top engine speed to factory limit
	Timing off	Check and adjust engine timing
White or blue exhaust smoke during all operating conditions	Excess engine oil	Check and correct the level
	Engine oil viscosity too low	Check and replace oil
	Faulty/late injection timing	Correct timing
Blue smoke on cold engine startup	Low combustion temperature	Check fuel injection timing, adjust inlet and exhaust valves, and test the cylinder
	Normal warm-up	May be difficult to stop blue smoke on startup completely
Dark exhaust smoke	Fuel cetane rating not optimal	Use only fuel with a cetane rating of 50 or higher
	Excess injection	Inspect and adjust (in service shop)
	Faulty function of the engine	Repair in service
	Overloading	Reduce the load
	Clogged air cleaner	Clean
	Leaks	Seal off all leaks
	Valve cover vent hose kinked or clogged	Shorten hose to 460 mm (18.1 inches)

422T/M2 TURBOCHARGER BEARING FAILURES

CAUSE	CORRECTION
Lack of lubrication during cold weather startup	Warm up below 1500 RPM for three minutes on start-up and allow to run at low idle for one minute before shutdown

422T/M2 ENGINE NOISE/WHISTLING

CAUSE	CORRECTION
Internal muffler restriction	Replace muffler
Turbocharger worn	Inspect turbocharger components

EXCESSIVE OIL CONSUMPTION (OR OIL SMOKE FROM EXHAUST)

CAUSE	CORRECTION
Leaks	Seal all leak sources
Valve cover vent hose kinked or clogged	Shorten hose to 460 mm (18.1 inches)

NOTE: See 422T/M2 *Excessive Oil Consumption on the next page for more extensive troubleshooting procedures.*



Suggest:

For more complete manuals. Please go to the home page.

<https://www.ebooklibonline.com>

If the above button click is invalid. Please download this document first, and then click the above link to download the complete manual.

Thank you so much for reading

422T/M2 - EXCESSIVE OIL CONSUMPTION

The maximum allowable oil consumption for the turbocharged diesel engine is 0.8%, as measured using a log of fuel consumption to oil consumption.

If a customer complains about excessive engine oil consumption on the Model 422/M2 or 422T/M2 Engines, the following steps must be taken. If a cause is found, stop and correct the problem. If a cause is not found, continue to the next step.

1. Examine engine for signs of external oil leaks.

- Check gaskets: oil pan, timing gear case, head, head cover, injection pump, oil gallery, and dipstick.
- Oil seals: crankshaft, front and rear.
- Steel tubing and fittings that supply oil to the turbocharger and upper engine.
- Tubing, hose, and fittings for turbocharger oil drain to block.
- Damage to oil pan and drain plug.
- Crankcase breather hose (open and not kinked) preventing proper crankcase breathing.

2. Examine turbocharger area.

- Remove the hose between the turbocharger inlet and the air cleaner. Examine for signs of dirt in the hose and inlet to the turbocharger blower.

If carbon, oil, and dust are found, check:

- Air cleaner assembly for tightness of filter elements.
- Hose between air cleaner and turbocharger for damage or looseness of clamps.

If oil residue is evident on the clean air turbine, it might not be due to failed turbocharger bearings.

Check the air filter and air intake hose for signs of oil residue.

Check the exhaust area for leaks:

- Exhaust manifold gasket and hardware.
- Turbocharger gasket and hardware, if equipped.
- Muffler gasket and hardware.

- Muffler failure (cranks, misalignment).

Remove the hose between the turbocharger outlet and the intake manifold. Check for dirt in the hose, turbocharger outlet, and the air intake manifold.

If there is not dirt at the turbocharger inlet but there is a deposit at the turbocharger blower outlet (which is not due to signs of dirt in the hose and inlet to the turbocharger blower), it may be leakage from the turbocharger seals.

Check turbocharger shaft specifications:

Axial movement: maximum 0.09 mm (0.0035 inch)

Radial movement: maximum 0.17 mm (0.0067 inch)

3. Check the blowby hose (valve cover vent hose) for signs of blockage. If the hose is kinked or the end is blocked by debris, correct by cutting off the end of the hose so it is just below the bottom of the engine oil filter.
4. If there is no problem found in the 1, 2, and 3 checking points, then go to the next step to log oil consumption.
5. The customer must log oil consumption using the following procedure:
 - Change the engine oil and filter. Use the oil specified in the operator's manual.
 - Run the engine for two minutes.
 - Check the dipstick and add oil, if required, so the level is at the fuel mark.
 - Fill the fuel tank with fuel.
 - Record fuel consumption (in gallons), oil added (in quarts), and hour reading. Record fuel and oil use for 100 hours of operation, which is the recommended oil change interval. Check the dipstick before running the engine each day.

The maximum allowable oil consumption is 0.8%. The following table gives examples.

Fuel Consumption, Gallons	Oil Consumption, Quarts
50	1.6
100	3.2
200	6.4

A log example is shown in the following table. The hour level is the Hourmeter reading when fuel is added. Dealer must file oil consumption log with customer file.

Fuel	Oil	Hour Level
Full	Full	100
XX Gallons	X Quart	150
XX Gallons	X Quart	200

6. If the oil consumption is greater than 0.8% of the fuel consumption, oil usage is excessive. A sample calculation for oil consumption follows:

$$\% \text{ Consumption} = \frac{\text{quarts oil}/4}{\text{gallons fuel}} \times 100$$

Assume one quart oil is added for 50 gallons fuel.

$$\% \text{ Consumption} = \frac{(1/4) \times 100}{50} = 0.5\%$$

7. The CNH dealer must check compression on all four cylinders and record.

The compression specifications are as follows:

Standard Value	To Be Repaired
More than 29.5 bar (429 PSI) at 200 - 250 engine cranking RPM	Less than 24.5 bar (356 PSI)

Compression testing can be performed using a special adapter (see "Special Tools" in the Additional Information Section) through the glow plug ports. Remove all glow plugs and test each cylinder.

This should be a "dry" compression check (do not put any oil in the cylinder).

If compression is low, recheck the air intake system for signs of dirt ingestion.

<https://www.ebooklibonline.com>

Hello dear friend!

Thank you very much for reading.

Enter the link into your browser.

The full manual is available for immediate download.

<https://www.ebooklibonline.com>