

## MODEL APPLICATION

Year	Model	Beginning Frame No.
2008	KLX450A8F	JKALXGA1□8A000001 or JKALX450AAA000001
2009	KLX450A9F	JKALXGA1□9A010001 or JKALX450AAA010001
2010	KLX450AAF	JKALXGA1□AA013001 or JKALX450AAA013001

□: This digit in the frame number changes from one machine to another.



KAWASAKI HEAVY INDUSTRIES, LTD.  
Consumer Products & Machinery Company

Part No.99924-1385-03

Printed in Japan

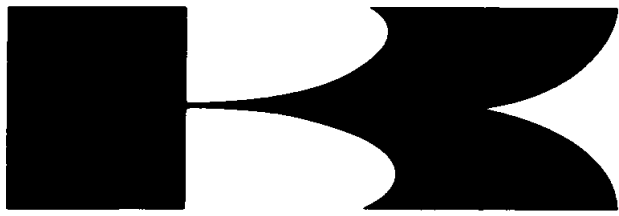

**Kawasaki**

**KLX450R**



# **Motorcycle Service Manual**

# Quick Reference Guide

<b>General Information</b>	<b>1</b>
<b>Periodic Maintenance</b>	<b>2</b>
<b>Fuel System</b>	<b>3</b>
<b>Cooling System</b>	<b>4</b>
<b>Engine Top End</b>	<b>5</b>
<b>Engine Right Side</b>	<b>6</b>
<b>Engine Lubrication System</b>	<b>7</b>
<b>Engine Removal/Installation</b>	<b>8</b>
<b>Crankshaft/Transmission</b>	<b>9</b>
<b>Wheels/Tires</b>	<b>10</b>
<b>Final Drive</b>	<b>11</b>
<b>Brakes</b>	<b>12</b>
<b>Suspension</b>	<b>13</b>
<b>Steering</b>	<b>14</b>
<b>Frame</b>	<b>15</b>
<b>Electrical System</b>	<b>16</b>
<b>Appendix</b>	<b>17</b>

**<https://www.ebooklibonline.com>**

Hello dear friend!

Thank you very much for reading.

Enter the link into your browser.

The full manual is available for immediate download.

**<https://www.ebooklibonline.com>**

# Foreword

This manual is designed primarily for use by trained mechanics in a properly equipped shop. However, it contains enough detail and basic information to make it useful to the owner who desires to perform his own basic maintenance and repair work. A basic knowledge of mechanics, the proper use of tools, and workshop procedures must be understood in order to carry out maintenance and repair satisfactorily. Whenever the owner has insufficient experience or doubts his ability to do the work, all adjustments, maintenance, and repair should be carried out only by qualified mechanics.

In order to perform the work efficiently and to avoid costly mistakes, read the text, thoroughly familiarize yourself with the procedures before starting work, and then do the work carefully in a clean area. Whenever special tools or equipment are specified, do not use makeshift tools or equipment. Precision measurements can only be made if the proper instruments are used, and the use of substitute tools may adversely affect safe operation.

**For the duration of the warranty period,** we recommend that all repairs and scheduled maintenance be performed in accordance with this service manual. Any owner maintenance or repair procedure not performed in accordance with this manual may void the warranty.

To get the longest life out of your vehicle:

- Follow the Periodic Maintenance Chart in the Service Manual.
- Be alert for problems and non-scheduled maintenance.
- Use proper tools and genuine Kawasaki Motorcycle parts. Special tools, gauges, and testers that are necessary when servicing Kawasaki motorcycles are introduced by the Service Manual. Genuine parts provided as spare parts are listed in the Parts Catalog.
- Follow the procedures in this manual carefully. Don't take shortcuts.
- Remember to keep complete records of maintenance and repair with dates and any new parts installed.

## How to Use This Manual

In this manual, the product is divided into its major systems and these systems make up the manual's chapters. The Quick Reference Guide shows you all of the product's system

and assists in locating their chapters. Each chapter in turn has its own comprehensive Table of Contents.

For example, if you want ignition coil information, use the Quick Reference Guide to locate the Electrical System chapter. Then, use the Table of Contents on the first page of the chapter to find the Ignition Coil section.

Whenever you see symbols, heed their instructions! Always follow safe operating and maintenance practices.

### **DANGER**

**DANGER** indicates a hazardous situation which, if not avoided, will result in death or serious injury.

### **WARNING**

**WARNING** indicates a hazardous situation which, if not avoided, could result in death or serious injury.

### **CAUTION**

**CAUTION** indicates a hazardous situation which, if not avoided, could result in minor or moderate injury.

### **NOTICE**

**NOTICE** is used to address practices not related to personal injury.

This manual contains four more symbols which will help you distinguish different types of information.

### **NOTE**

○ *This note symbol indicates points of particular interest for more efficient and convenient operation.*

● Indicates a procedural step or work to be done.

○ Indicates a procedural sub-step or how to do the work of the procedural step it follows. It also precedes the text of a NOTE.

★ Indicates a conditional step or what action to take based on the results of the test or inspection in the procedural step or sub-step it follows.

In most chapters an exploded view illustration of the system components follows the Table of Contents. In these illustrations you will find the

instructions indicating which parts require specified tightening torque, oil, grease or a locking

agent during assembly.

# General Information

## Table of Contents

Before Servicing .....	1-2
Model Identification.....	1-7
General Specifications.....	1-8
Unit Conversion Table .....	1-11

# 1-2 GENERAL INFORMATION

## Before Servicing

Before starting to perform an inspection service or carry out a disassembly and reassembly operation on a motorcycle, read the precautions given below. To facilitate actual operations, notes, illustrations, photographs, cautions, and detailed descriptions have been included in each chapter wherever necessary. This section explains the items that require particular attention during the removal and reinstallation or disassembly and reassembly of general parts.

Especially note the following:

### **Battery Ground**

Before completing any service on the motorcycle, disconnect the battery cables from the battery to prevent the engine from accidentally turning over. Disconnect the ground cable (-) first and then the positive (+). When completed with the service, first connect the positive (+) cable to the positive (+) terminal of the battery then the negative (-) cable to the negative terminal.

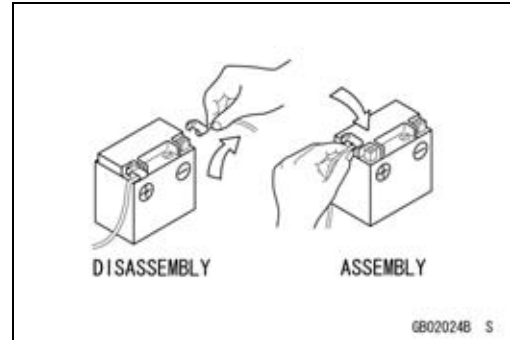

### **Edges of Parts**

Lift large or heavy parts wearing gloves to prevent injury from possible sharp edges on the parts.

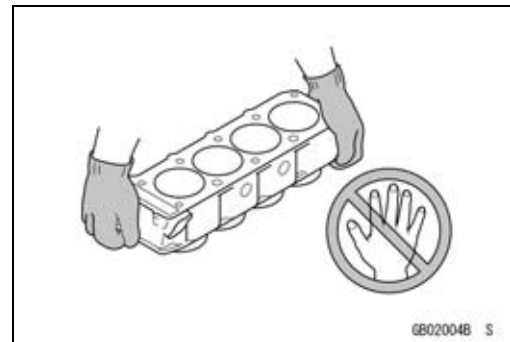

### **Solvent**

Use a high-flash point solvent when cleaning parts. High-flash point solvent should be used according to directions of the solvent manufacturer.

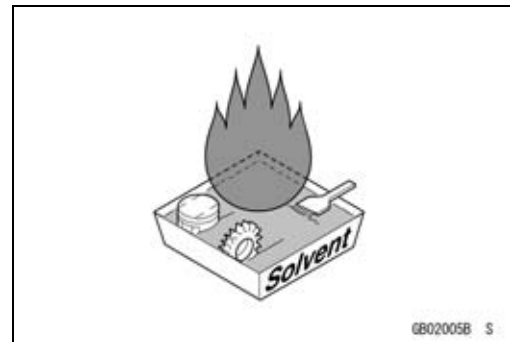

### **Cleaning vehicle before disassembly**

Clean the vehicle thoroughly before disassembly. Dirt or other foreign materials entering into sealed areas during vehicle disassembly can cause excessive wear and decrease performance of the vehicle.

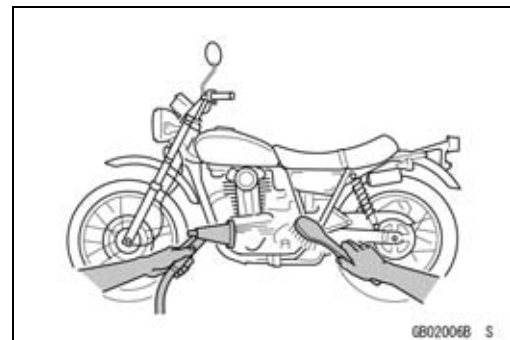

**Before Servicing**

**Arrangement and Cleaning of Removed Parts**

Disassembled parts are easy to confuse. Arrange the parts according to the order the parts were disassembled and clean the parts in order prior to assembly.

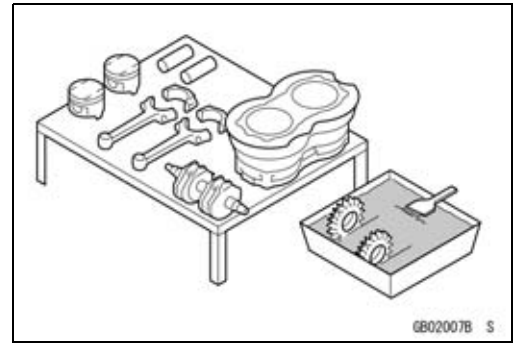

**Storage of Removed Parts**

After all the parts including subassembly parts have been cleaned, store the parts in a clean area. Put a clean cloth or plastic sheet over the parts to protect from any foreign materials that may collect before re-assembly.

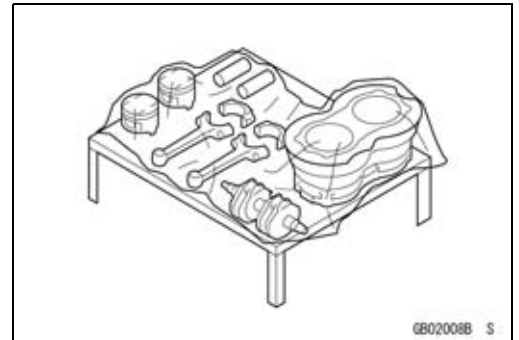

**Inspection**

Reuse of worn or damaged parts may lead to serious accident. Visually inspect removed parts for corrosion, discoloration, or other damage. Refer to the appropriate sections of this manual for service limits on individual parts. Replace the parts if any damage has been found or if the part is beyond its service limit.

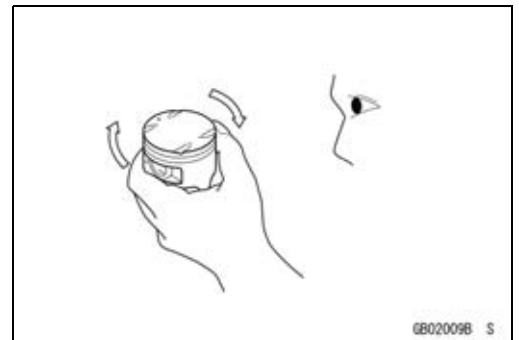

**Replacement Parts**

Replacement Parts must be KAWASAKI genuine or recommended by KAWASAKI. Gaskets, O-rings, Oil seals, Grease seals, circlips or cotter pins must be replaced with new ones whenever disassembled.

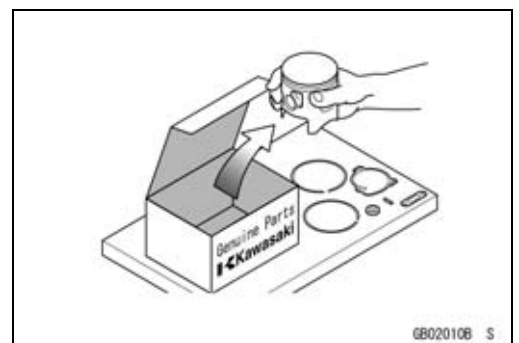

**Assembly Order**

In most cases assembly order is the reverse of disassembly, however, if assembly order is provided in this Service Manual, follow the procedures given.

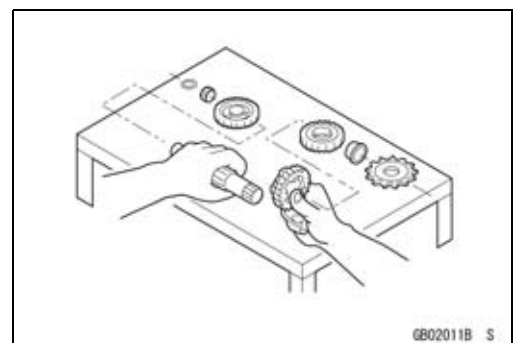

# 1-4 GENERAL INFORMATION

## Before Servicing

### **Tightening Sequence**

Generally, when installing a part with several bolts, nuts, or screws, start them all in their holes and tighten them to a snug fit. Then tighten them according to the specified sequence to prevent case warpage or deformation which can lead to malfunction. Conversely when loosening the bolts, nuts, or screws, first loosen all of them by about a quarter turn and then remove them. If the specified tightening sequence is not indicated, tighten the fasteners alternating diagonally.

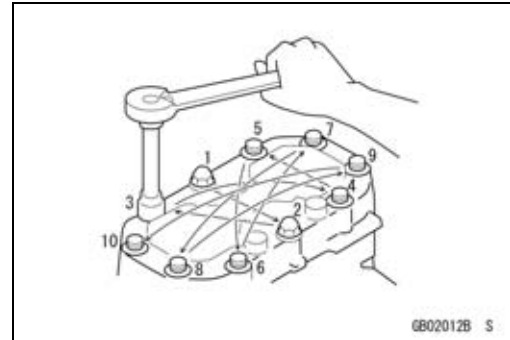

### **Tightening Torque**

Incorrect torque applied to a bolt, nut, or screw may lead to serious damage. Tighten fasteners to the specified torque using a good quality torque wrench.

Often, the tightening sequence is followed twice-initial tightening and final tightening with torque wrench.

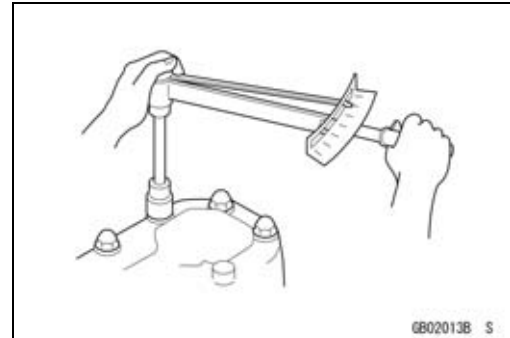

### **Force**

Use common sense during disassembly and assembly, excessive force can cause expensive or hard to repair damage. When necessary, remove screws that have a non-permanent locking agent applied using an impact driver. Use a plastic-faced mallet whenever tapping is necessary.

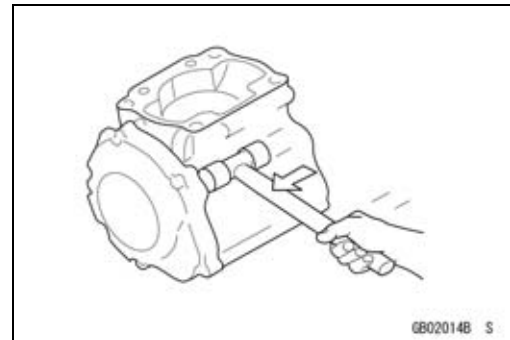

### **Gasket, O-ring**

Hardening, shrinkage, or damage of both gaskets and O-rings after disassembly can reduce sealing performance. Remove old gaskets and clean the sealing surfaces thoroughly so that no gasket material or other material remains. Install new gaskets and replace used O-rings when re-assembling.

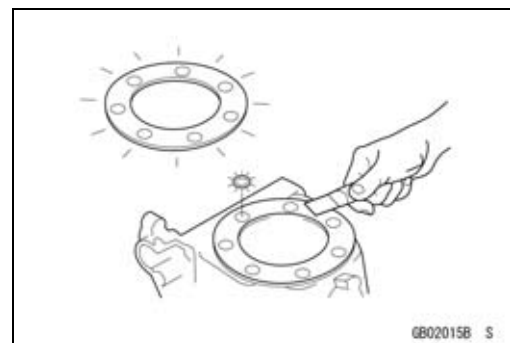

### **Liquid Gasket, Non-permanent Locking Agent**

For applications that require Liquid Gasket or a Non-permanent Locking agent, clean the surfaces so that no oil residue remains before applying liquid gasket or Non-permanent locking agent. Do not apply them excessively. Excessive application can clog oil passages and cause serious damage.



**Before Servicing**

**Press**

For items such as bearings or oil seals that must be pressed into place, apply small amount of oil to the contact area. Be sure to maintain proper alignment and use smooth movements when installing.

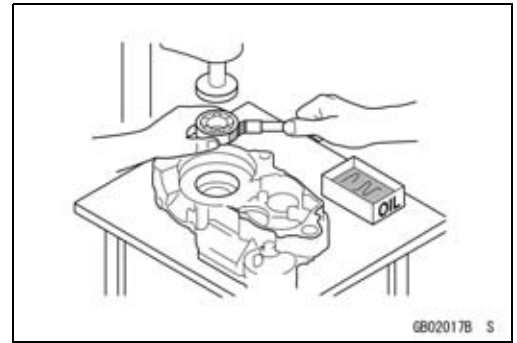

**Ball Bearing and Needle Bearing**

Do not remove pressed ball or needle unless removal is absolutely necessary. Replace with new ones whenever removed. Press bearings with the manufacturer and size marks facing out. Press the bearing into place by putting pressure on the correct bearing race as shown.

Pressing the incorrect race can cause pressure between the inner and outer race and result in bearing damage.

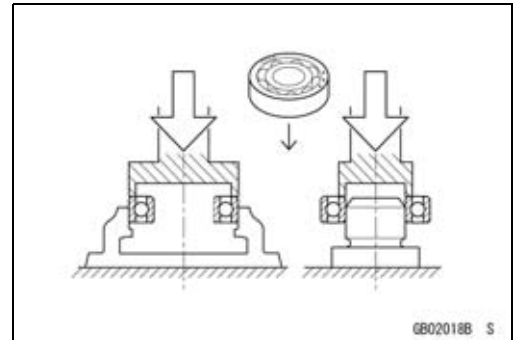

**Oil Seal, Grease Seal**

Do not remove pressed oil or grease seals unless removal is necessary. Replace with new ones whenever removed. Press new oil seals with manufacture and size marks facing out. Make sure the seal is aligned properly when installing.

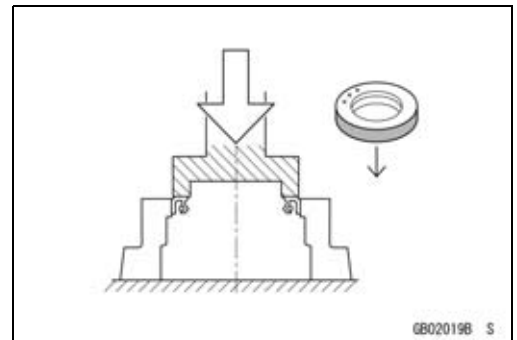

Apply specified grease to the lip of seal before installing the seal.

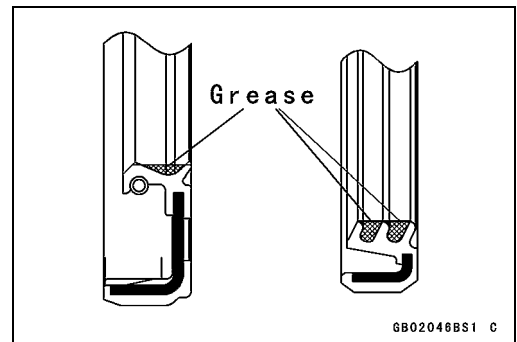

**Circlips, Cotter Pins**

Replace circlips or cotter pins that were removed with new ones. Take care not to open the clip excessively when installing to prevent deformation.

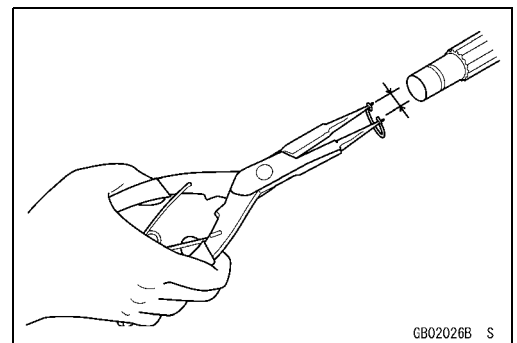

## 1-6 GENERAL INFORMATION

### Before Servicing

#### **Lubrication**

It is important to lubricate rotating or sliding parts during assembly to minimize wear during initial operation. Lubrication points are called out throughout this manual, apply the specific oil or grease as specified.

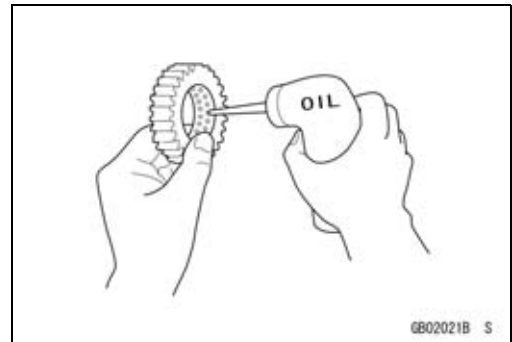

#### **Direction of Engine Rotation**

When rotating the crankshaft by hand, the free play amount of rotating direction will affect the adjustment. Rotate the crankshaft to positive direction (clockwise viewed from output side).

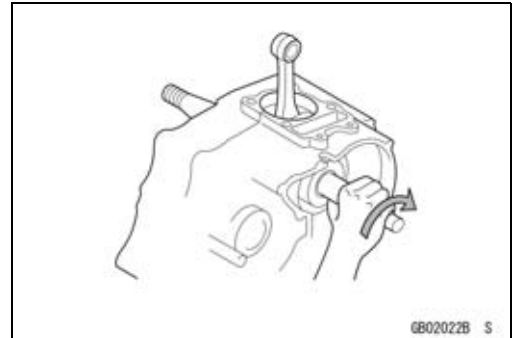

#### **Electrical Leads**

A two-color lead is identified first by the primary color and then the stripe color. Unless instructed otherwise, electrical leads must be connected to those of the same color.

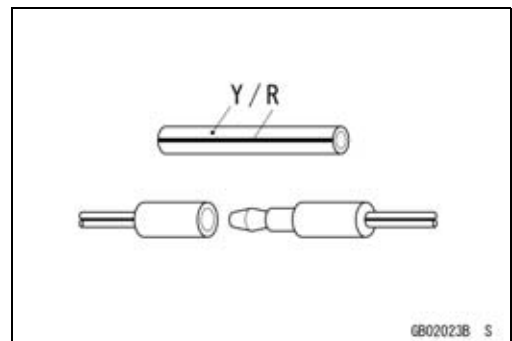

#### **Instrument**

Use a meter that has enough accuracy for an accurate measurement. Read the manufacturer's instructions thoroughly before using the meter. Incorrect values may lead to improper adjustments.

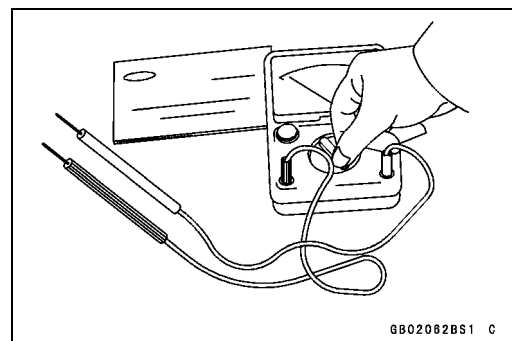

Model Identification

KLX450A8F Left Side View



KLX450A8F Right Side View



Frame Number



Engine Number



# 1-8 GENERAL INFORMATION

## General Specifications

Items	KLX450A8F ~ AAF
<b>Dimensions</b> Overall Length Overall Width Overall Height Wheelbase Road Clearance Seat Height Dry Mass Curb Mass Fuel Tank Capacity	2 180 mm (85.83 in.), (AU) (EUR) 2 175 mm (85.63 in.) 820 mm (32.3 in.) 1 255 mm (49.41 in.), (AU) (EUR) 1 250 mm (49.21 in.) 1 480 mm (58.27 in.) 320 mm (12.6 in.), (AU) (EUR) 315 mm (12.4 in.) 940 mm (37.0 in.), (AU) (EUR) 935 mm (36.8 in.) (KLX450A8F) 115 kg (254 lb) (KLX450A9F ~ AAF) 126 kg (278 lb) 8 L (2.1 US gal)
<b>Performance</b> Minimum Turning Radius	–
<b>Engine</b> Type Cooling System Bore and Stroke Displacement Compression Ratio Carburetion System Starting System Ignition System Timing Advance Ignition Timing Spark Plug Valve Timing: Inlet: Open Close Duration Exhaust: Open Close Duration Lubrication System Engine Oil: Type Viscosity Capacity	4-stroke, single cylinder, DOHC 4 valve Liquid-cooled 96.0 × 62.1 mm (3.78 × 2.44 in.) 449 cm <sup>3</sup> (27.4 cu in.) 12.0 : 1 Carburetor, KEIHIN FCR-MX40 Electric starter, Primary kick Digital AC-CDI BTDC 10.2° @1 800 r/min (rpm) NGK CPR8EB-9 BTDC 38° ABDC 66° 284° BBDC 68° ATDC 36° 284° Forced lubrication (semi-dry sump) API SG, SH, SJ, SL or SM with JASO MA, MA1 or MA2 SAE 10W-30, 10W-40, 10W-50 1.3 L (1.4 US qt)
<b>Drive Train</b> Primary Reduction System: Type Reduction Ratio Clutch Type	Gear 2.727 (60/22) Wet, multi disc

## General Specifications

Items	KLX450A8F ~ AAF
Transmission: Type Gear ratios: 1st 2nd 3rd 4th 5th Final Drive System: Type Reduction Ratio Overall Drive Ratio	5-speed, constant mesh, return shift  2.167 (26/12) 1.533 (23/15) 1.188 (19/16) 0.950 (19/20) 0.810 (17/21)  Chain drive 3.846 (50/13) 8.492 @Top gear
<b>Frame</b> Type Steering Angle Caster (rake angle) Trail Front tire: Size Make/Type Rear tire: Size Make/Type Rim size: Front Rear Front suspension: Type Wheel travel Rear suspension: Type Wheel travel Brake type: Front and Rear Effective disc diameter: Front (effect. dia.) Rear (effect. dia.)	Tubular, semi-double cradle 42° to either side 27.7°, (AU) (EUR) 28° 122 mm (4.80 in.)  80/100-21 51M, (AU) (EUR) 80/100-21 M/C 51P BRIDGESTONE M401, Tube type, (AU) (EUR) ED03, Tube type  110/100-18 64M, (AU) (EUR) 120/90-18 M/C 65P BRIDGESTONE M402, Tube type, (AU) (EUR) ED04, Tube type  21 x 1.60 18 x 2.15  Telescopic fork (up side down) 305 mm (12.0 in.)  Swingarm (New Uni-trak) 315 mm (12.4 in.)  Single disc  225 mm (8.86 in.) 215 mm (8.46 in.)
<b>Electrical Equipment</b> Battery Headlight: Type Bulb	12 V 6 Ah  Semi-sealed beam 12 V 35 W/35 W (Hi/Lo)

## 1-10 GENERAL INFORMATION

### General Specifications

Items	KLX450A8F ~ AAF
Tail Light Magneto: Rated Output	LED  2.0 A/14 V

Specifications subject to change without notice, and may not apply to every country.

**Unit Conversion Table**

**Prefixes for Units:**

Prefix	Symbol	Power
mega	M	× 1 000 000
kilo	k	× 1 000
centi	c	× 0.01
milli	m	× 0.001
micro	μ	× 0.000001

**Units of Mass:**

kg	×	2.205	=	lb
g	×	0.03527	=	oz

**Units of Volume:**

L	×	0.2642	=	gal (US)
L	×	0.2200	=	gal (imp)
L	×	1.057	=	qt (US)
L	×	0.8799	=	qt (imp)
L	×	2.113	=	pint (US)
L	×	1.816	=	pint (imp)
mL	×	0.03381	=	oz (US)
mL	×	0.02816	=	oz (imp)
mL	×	0.06102	=	cu in

**Units of Force:**

N	×	0.1020	=	kgf
N	×	0.2248	=	lb
kgf	×	9.807	=	N
kgf	×	2.205	=	lb

**Units of Length:**

km	×	0.6214	=	mile
m	×	3.281	=	ft
mm	×	0.03937	=	in

**Units of Torque:**

N·m	×	0.1020	=	kgf·m
N·m	×	0.7376	=	ft·lb
N·m	×	8.851	=	in·lb
kgf·m	×	9.807	=	N·m
kgf·m	×	7.233	=	ft·lb
kgf·m	×	86.80	=	in·lb

**Units of Pressure:**

kPa	×	0.01020	=	kgf/cm <sup>2</sup>
kPa	×	0.1450	=	psi
kPa	×	0.7501	=	cm Hg
kgf/cm <sup>2</sup>	×	98.07	=	kPa
kgf/cm <sup>2</sup>	×	14.22	=	psi
cm Hg	×	1.333	=	kPa

**Units of Speed:**

km/h	×	0.6214	=	mph
------	---	--------	---	-----

**Units of Power:**

kW	×	1.360	=	PS
kW	×	1.341	=	HP
PS	×	0.7355	=	kW
PS	×	0.9863	=	HP

**Units of Temperature:**

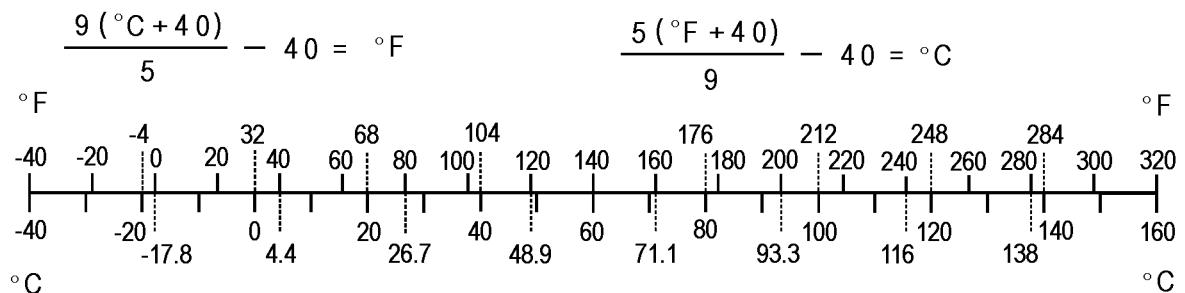

# Periodic Maintenance

## Table of Contents

Periodic Maintenance Chart .....	2-2	Air Pressure Inspection/Adjustment .....	2-29
Torque and Locking Agent.....	2-4	Tires Inspection.....	2-30
Specifications .....	2-9	Spoke Tightness Inspection .....	2-30
Special Tools .....	2-11	Rim Runout Inspection.....	2-31
Periodic Maintenance Procedures.....	2-12	Wheel Bearing Inspection .....	2-31
Fuel System.....	2-12	Final Drive.....	2-32
Fuel Hose and Connection		Drive Chain Slack Inspection .....	2-32
Inspection.....	2-12	Drive Chain Slack Adjustment .....	2-32
Throttle Grip Free Play Inspection	2-12	Drive Chain Wear Inspection .....	2-33
Throttle Grip Free Play		Drive Chain Lubrication.....	2-34
Adjustment .....	2-12	Sprocket Wear Inspection.....	2-34
Hot Starter Lever Free Play		Rear Sprocket Warp Inspection .....	2-35
Inspection.....	2-13	Brakes.....	2-35
Idle Speed Inspection .....	2-13	Brake Lever and Pedal Position	
Idle Speed Adjustment.....	2-14	Adjustment .....	2-35
Air Cleaner Element Cleaning and		Brake Fluid Level Inspection.....	2-36
Inspection.....	2-14	Brake Fluid Change .....	2-37
Fuel Inspection.....	2-16	Brake Pad Wear Inspection .....	2-39
Fuel Tank, Filter and Tap		Brake Master Cylinder Cup and	
Cleaning .....	2-17	Dust Seal Replacement .....	2-39
Fuel Tap and Filter Inspection.....	2-17	Caliper Piston Seal and Dust Seal	
Cooling System.....	2-17	Replacement.....	2-41
Coolant Level Inspection.....	2-18	Brake Hose and Connection	
Coolant Deterioration Inspection..	2-18	Check .....	2-44
Radiator Hoses and Connections		Brake Hose Replacement.....	2-44
Inspection.....	2-19	Suspension .....	2-45
Engine Top End .....	2-19	Front Fork Inspection .....	2-45
Vacuum Switch Valve Test .....	2-19	Front Fork Oil Change (each fork	
Valve Clearance Inspection .....	2-20	leg) .....	2-45
Valve Clearance Adjustment.....	2-21	Rear Shock Absorber Inspection .	2-54
Cylinder Head Warp Inspection ...	2-23	Rear Shock Absorber Oil Change	2-54
Cylinder Wear Inspection.....	2-23	Swingarm and Uni-Trak Linkage	
Piston/Cylinder Clearance .....	2-24	Inspection.....	2-59
Piston, Piston Ring and Piston		Swingarm and Uni-Track Linkage	
Pin Replacement.....	2-24	Pivot Lubricate .....	2-59
Spark Arrester Cleaning.....	2-24	Steering .....	2-59
Engine Right Side .....	2-25	Steering Inspection .....	2-59
Clutch Lever Free Play Check .....	2-25	Steering Adjustment .....	2-59
Clutch Lever Free Play		Stem Bearing Lubrication.....	2-61
Adjustment .....	2-26	Frame .....	2-61
Friction and Steel Plates		Frame Inspection .....	2-61
Inspection.....	2-26	Electrical System .....	2-62
Engine Lubrication System.....	2-26	Spark Plug Cleaning and	
Engine Oil Change.....	2-26	Inspection.....	2-62
Oil Filter Change .....	2-27	Cable Inspection .....	2-62
Breather Hose Inspection .....	2-28	Lubrication .....	2-62
Crankshaft/Transmission .....	2-29	Nut, Bolt, and Fastener Tightness	
Crankshaft Inspection .....	2-29	Inspection.....	2-63
Wheel/Tires.....	2-29	Tightness Inspection .....	2-63

## 2-2 PERIODIC MAINTENANCE

### Periodic Maintenance Chart

The maintenance must be done in accordance with this chart to keep the motorcycle in good running condition.

#### Periodic Inspection

		FREQUENCY	Traveled Distance km (mi)					See Page	
			Every 100 (60) or 2.5 hr	Every 500 (300) or 7.5 hr	Every 1000 (600) or 15 hr	Every 1500 (900) or 30 hr	Every 2000 (1200) or 60 hr		
OPERATION	Spark plug-clean, gap †		Every 500 km (300 mi)					2 - 62	
	Spark plug-inspect †		●	●	●	●	2 - 62		
	Clutch cable-adjust		Every 100 km (60 mi)					2 - 26	
	Clutch and friction plates-inspect †	●	●	●	●	●	2 - 26		
		After 2000 km (1200 mi), every 1000 km (600 mi)							
	Throttle cable-adjust		Every 100 km (60 mi)					2 - 12	
	Air cleaner element-clean †	●	●	●	●	●	2 - 14		
		After 2000 km (1200 mi), every 1000 km (600 mi)							
	ENGINE	Carburetor-inspect and adjust	●	●	●	●	●	2 - 12	
		Cylinder head, cylinder-inspect			●		●	2 - 23	
		Valve clearance-inspect †	●		●		●	2 - 20	
			After 2000 km (1200 mi), every 1000 km (600 mi)						
		Hot starter cable-adjust		Every 100 km (60 mi)					2 - 13
		Spark arrester-clean		Every 1500 km (900 mi)					2 - 24
		Vacuum switch valve-inspect †			●		●	2 - 19	
		Kick pedal and shift pedal-clean	●	●	●	●	●	—	
		Engine sprocket-inspect †	●	●	●	●	●	2 - 34	
		Coolant-inspect †	●	●	●	●	●	2 - 18	
		Radiator hoses and connections-inspect †	●	●	●	●	●	2 - 19	
		Crankshaft-inspect			●		●	2 - 29	
Breather hose-inspect		●	●	●	●	●	2 - 28		
CHASSIS	Brake adjustment-inspect †	●	●	●	●	●	2 - 35		
	Brake pad wear-inspect †	●	●	●	●	●	2 - 39		
	Brake fluid level-inspect †	●	●	●	●	●	2 - 36		
	Brake hoses, connections-inspect †	●	●	●	●	●	2 - 44		
	Spoke tightness and rim runout-inspect †	●	●	●	●	●	2 - 30		
	Wheel bearing-inspect †	●	●	●	●	●	2 - 31		
	Frame-inspect and clean	●	●	●	●	●	2 - 61		
	Drive chain wear-inspect †	●	●	●	●	●	2 - 33		
	Drive chain-inspect and adjust	●	●	●	●	●	2 - 32		
	Drive chain-lubricate	●	●	●	●	●	2 - 34		
Wheels/tires-inspect	●	●	●	●	●	2 - 30			

**Periodic Maintenance Chart**

OPERATION		FREQUENCY	Traveled Distance km (mi)					See Page
			Every 100 (60) or 2.5 hr	Every 500 (300) or 7.5 hr	Every 1000 (600) or 15 hr	Every 1500 (900) or 30 hr	Every 2000 (1200) or 60 hr	
C H A S S I S	Rear sprocket-inspect †	●	●	●	●	●	2 - 35	
	Front fork-inspect and clean	●	●	●	●	●	2 - 45	
	Cable-inspect	●	●	●	●	●	2 - 62	
	Fuel hose, connections-inspect †		●	●	●	●	2 - 12	
	Fuel system-clean	●	●	●	●	●	2 - 17	
	Steering play-inspect †	●	●	●	●	●	2 - 59	
	Steering stem bearing-grease			●		●	2 - 61	
	Swingarm and Uni-Trak linkage pivots-grease		●	●	●	●	2 - 59	
	Swingarm and Uni-Trak linkage pivots-inspect †		●	●	●	●	2 - 59	
	Nuts, bolts, fasteners-inspect †	●	●	●	●	●	2 - 63	
	Rear shock absorber-inspect	●	●	●	●	●	2 - 54	
Chassis parts-lubricate	●	●	●	●	●	—		

†: Replace, add, adjust, clean or torque if necessary.

**Periodic Replacement Parts**

OPERATION		FREQUENCY	Traveled Distance km (mi)					See Page
			Every 100 (60) or 2.5 hr	Every 500 (300) or 7.5 hr	Every 1000 (600) or 15 hr	Every 1500 (900) or 30 hr	Every 2000 (1200) or 60 hr	
Engine oil-change			Every 1000 km (600 mi)					2 - 26
Piston and piston ring-replace			Every 1500 km (900 mi)					2 - 24
Piston pin-replace			Every 1500 km (900 mi)					2 - 24
Oil filter-replace			Every 1000 km (600 mi)					2 - 27
Brake fluid-change			Every 2 years					2 - 37
Brake master cylinder cup and dust seal-replace			Every 2 years					2 - 39
Brake caliper piston seal and dust seal-replace			Every 2 years					2 - 41
Brake hoses-replace			Every 4 years					2 - 44
Front fork oil-change				●			●	2 - 45
Rear shock oil-replace				●			●	2 - 54
Fuel hose-replace			Every 4 years					2 - 12

## 2-4 PERIODIC MAINTENANCE

### Torque and Locking Agent

Tighten all bolts and nuts to the proper torque using an accurate torque wrench. If insufficiently tightened, a bolt or nut may become damaged, strip an internal thread, or break and then fall out. The following table lists the tightening torque for the major bolts and nuts, and the parts requiring use of a non-permanent locking agent or liquid gasket.

When checking the tightening torque of the bolts and nuts, first loosen the bolt or nut by half a turn and then tighten to specified torque.

Letters used in the "Remarks" column mean:

AL: Tighten the two clamp bolts alternately two times to ensure even tightening torque.

HL: Apply high-locking agent.

L: Apply a non-permanent locking agent to the threads.

Lh: Left-hand Threads

MO: Apply molybdenum disulfide oil.

S: Tighten the fasteners following the specified sequence.

Si: Apply Silicone grease.

R: Replacement Parts

2T: Apply 2-stroke oil.

T: First, tighten the stem locknut with 39 N·m (4.0 kgf·m, 29 ft·lb) of torque, then loosen it and retighten it with 4.9 N·m (0.50 kgf·m, 43 in·lb) of torque.

Fastener	Torque			Remarks
	N·m	kgf·m	ft·lb	
<b>Fuel System</b>				
Throttle Pulley Cover Bolt	3.4	0.35	30 in·lb	
Throttle Cable Mounting Bolts	6.9	0.70	61 in·lb	
Vacuum Switch Valve Bracket Bolts	9.8	1.0	87 in·lb	
Fuel Tap Knob Screws	0.80	0.080	7.0 in·lb	
Rear Frame Mounting Bolts	34	3.5	25	
<b>Cooling System</b>				
Water Pump Cover Bolts	9.8	1.0	87 in·lb	
Coolant Drain Plug	7.0	0.70	62 in·lb	
Water Pump Impeller Bolt	9.8	1.0	87 in·lb	
Right Engine Cover Bolts	9.8	1.0	87 in·lb	
Radiator Hose Clamp Screws	3.0	0.30	27 in·lb	
<b>Engine Top End</b>				
Cylinder Head Cover Bolts	9.8	1.0	87 in·lb	
Cylinder Head Bolts (M10)	59	6.0	44	S, MO
Cylinder Head Bolts (M6)	12	1.2	106 in·lb	S
Cylinder Bolt	12	1.2	106 in·lb	
Camshaft Cap Bolts	9.8	1.0	87 in·lb	S, MO
Camshaft Sprocket Bolts	12	1.2	106 in·lb	L
Carburetor Holder Clamp Screws	2.0	0.20	18 in·lb	
Plug	20	2.0	15	L
Rear Camshaft Chain Guide Bolt	15	1.5	11	
Oil Pump (Scavenge) Cover Bolts	9.8	1.0	87 in·lb	
Chain Tensioner Mounting Bolts	9.8	1.0	87 in·lb	
Chain Tensioner Cap Bolt	5.0	0.51	44 in·lb	
Water Hose Fitting Bolts	9.8	1.0	87 in·lb	
Oil Line Plug	3.0	0.31	27 in·lb	L
Decompressor Plug Plate Bolt	9.8	1.0	87 in·lb	

## PERIODIC MAINTENANCE 2-5

### Torque and Locking Agent

Fastener	Torque			Remarks
	N-m	kgf-m	ft-lb	
Vacuum Hose Fitting	8.8	0.90	78 in-lb	L
Cylinder Head Pipe Mounting Bolt	9.8	1.0	87 in-lb	
Exhaust Pipe Cover Bolts	12	1.2	106 in-lb	
Rear Muffler Mounting Bolt	20	2.0	15	
Front Muffler Mounting Bolt (First)	9.8	1.0	87 in-lb	
Front Muffler Mounting Bolt (Final)	20	2.0	15	
Exhaust Pipe Holder Nuts	20	2.0	15	
Muffler End Mounting Bolts	10	1.0	89 in-lb	
Spark Arrester Mounting Bolts	10	1.0	89 in-lb	
<b>Engine Right Side</b>				
Primary Gear Nut	98	10	72	Lh,R
Clutch Cover Bolts	9.8	1.0	87 in-lb	
Right Engine Cover Bolts	9.8	1.0	87 in-lb	
Clutch Spring Bolts	8.8	0.90	78 in-lb	
Clutch Hub Nut	98	10	72	R
Ratchet Guide Bolt	8.8	0.90	78 in-lb	
Kick Pedal Bolt	25	2.5	18	L
Ratchet Plate Mounting Bolt	9.8	1.0	87 in-lb	S
Ratchet Plate Mounting Screw	6.4	0.65	56 in-lb	L,S
Gear Set Lever Nut	8.8	0.90	78 in-lb	
Shift Drum Cam Bolt	24	2.4	18	L
<b>Engine Lubrication System</b>				
Engine Oil Drain Plug (M10) (Main)	20	2.0	15	
Engine Oil Drain Plug (M6) (Sub)	7.0	0.71	62 in-lb	
Oil Pump (Scavenge) Cover Bolts	9.8	1.0	87 in-lb	
Oil Pump (Feed) Cover Bolts	9.8	1.0	87 in-lb	
Right Engine Cover Bolts	9.8	1.0	87 in-lb	
Piston Oil Nozzle	5.0	0.50	44 in-lb	
Oil Filter Cover Bolt	9.8	1.0	87 in-lb	
Oil Screen (Feed) Mounting Bolts	9.8	1.0	87 in-lb	
Oil Pressure Relief Valve	15	1.5	11	HL
Breather Fitting	15	1.5	11	L
Oil Filler Cap	–	–	–	Hand-tighten
<b>Engine Removal/Installation</b>				
Upper Engine Mounting Bolts (M10)	49	5.0	36	
Middle Engine Mounting Nut (M10)	49	5.0	36	
Lower Engine Mounting Nut (M10)	49	5.0	36	
Upper Engine Bracket Bolts (M8)	29	3.0	21	
Middle Engine Bracket Nuts (M8)	29	3.0	21	
Swingarm Pivot Shaft Nut	98	10	72	
<b>Crankshaft/Transmission</b>				
Crankcase Bolts (M6)	12	1.2	106 in-lb	S
Crankcase Bolts (M7)	15	1.5	11	S

## 2-6 PERIODIC MAINTENANCE

### Torque and Locking Agent

Fastener	Torque			Remarks
	N-m	kgf-m	ft-lb	
Gear Set Lever Nut	8.8	0.90	78 in-lb	
Engine Oil Drain Plug (M6)(Sub)	7.0	0.71	62 in-lb	
Engine Oil Drain Plug (M10)(Main)	20	2.0	15	
Shift Drum Cam Bolt	24	2.4	18	L
Piston Oil Nozzle	4.0	0.41	35 in-lb	
Bearing Retaining Screws	15	1.5	11	L
Balancer Weight Mounting Nut	52	5.3	38	
Gear Position Switch Screws	2.9	0.30	26 in-lb	L
<b>Wheels/Tires</b>				
Spoke Nipples	2.2	0.22	19 in-lb	
Front Axle Nut	79	8.0	58	
Front Axle Clamp Bolts	20	2.0	15	AL
Rear Axle Nut	110	11.2	81.1	
<b>Final Drive</b>				
Rear Sprocket Nuts	34	3.5	25	
Engine Sprocket Nut	127	13.0	93.7	
<b>Brakes</b>				
Front Master Cylinder Clamp Bolts	8.8	0.90	78 in-lb	S
Brake Hose Banjo Bolts	25	2.5	18	
Brake Pad Bolt	17	1.7	13	
Caliper Bleed Valve	7.8	0.80	69 in-lb	
Caliper Mounting Bolts	25	2.5	18	
Front Brake Disc Mounting Bolts	10	1.0	89 in-lb	L
Brake Lever Pivot Bolt Locknut	5.9	0.60	52 in-lb	
Brake Lever Pivot Bolt	5.9	0.60	52 in-lb	Si
Brake Reservoir Cap Screws	1.5	0.15	13 in-lb	
Front Brake Light Switch Screw	1.2	0.12	10 in-lb	
Brake Hose Banjo Bolts	25	2.5	18	
Rear Master Cylinder Mounting Bolts	10	1.0	89 in-lb	
Rear Master Cylinder Push Rod Locknut	17	1.7	13	
Caliper Bleed Valve	7.8	0.80	69 in-lb	
Brake Pad Bolt	17	1.7	13	
Rear Brake Pad Bolt Plug	2.4	0.24	21 in-lb	
Caliper Holder Shaft	27	2.8	20	Si
Brake Pedal Mounting Bolt	25	2.5	18	G,L
Rear Brake Disc Mounting Bolts	23	2.3	17	L
Brake Reservoir Cap Bolts	1.5	0.15	13 in-lb	
<b>Suspension</b>				
Base Valve Assembly	28	2.9	21	
Front Fork Top Plug	30	3.1	22	
Front Fork Clamp Bolts (Upper)	20	2.0	15	AL
Front Fork Clamp Bolts (Lower)	20	2.0	15	AL
Steering Stem Head Nut	98	10	72	

## PERIODIC MAINTENANCE 2-7

### Torque and Locking Agent

Fastener	Torque			Remarks
	N·m	kgf·m	ft·lb	
Locknut/Adjuster Assembly	29	3.0	21	L AL
Adjuster Assembly	55	5.6	41	
Front Axle Clamp Bolts	20	2.0	15	
Swingarm Pivot Shaft Nut	98	10	72	
Rocker Arm Pivot Nut	59	6.0	44	
Tie-rod Mounting Nut (Front, Rear)	59	6.0	44	
Rear Shock Absorber Mounting Nut (Upper)	39	4.0	29	
Rear Shock Absorber Mounting Nut (Lower)	34	3.5	25	
Air Bleed Bolt	6.5	0.66	58 in·lb	
<b>Steering</b>				
Handlebar Clamp Bolts	25	2.5	18	2T
Steering Stem Head Nut	98	10	72	
Steering Stem Nut	4.9	0.50	43 in·lb	T
Front Fork Clamp Bolts (Upper)	20	2.0	15	AL
Front Fork Clamp Bolts (Lower)	20	2.0	15	AL
<b>Frame</b>				
Rear Frame Mounting Bolt	34	3.5	25	
Upper Footpeg Bracket Bolts	54	5.5	40	L
<b>Electrical System</b>				
Spark Plug	13	1.3	115 in·lb	
Starter Motor Terminal Nut	5.9	0.60	52 in·lb	
Starter Motor Mounting Bolts	9.8	1.0	87 in·lb	
Crankshaft Sensor Bolts	7.0	0.71	62 in·lb	
Stator Bolts	4.0	0.41	35 in·lb	L
Flywheel Nut	98	10	72	
Magneto Cover Bolts	9.8	1.0	87 in·lb	
Timing Inspection Cap	–	–	–	Hand-Tighten
Flywheel Nut Cap	–	–	–	Hand-Tighten
Torque Limiter Cover Bolts	9.8	1.0	87 in·lb	
Starter Motor Terminal Locknut	6.9	0.70	61 in·lb	
Starter Motor Through Bolts	3.4	0.35	30 in·lb	
Breather Fitting	15	1.5	11	L
Head Light Bracket Screws	1.4	0.14	12 in·lb	
Gear Position Switch Screws	2.9	0.30	26 in·lb	L

## 2-8 PERIODIC MAINTENANCE

### Torque and Locking Agent

#### Basic Torque for General Fasteners

Threads dia. (mm)	Torque		
	N·m	kgf·m	ft·lb
5	3.4 ~ 4.9	0.35 ~ 0.50	30 ~ 43 in·lb
6	5.9 ~ 7.8	0.60 ~ 0.80	52 ~ 69 in·lb
8	14 ~ 19	1.4 ~ 1.9	10.0 ~ 13.5
10	25 ~ 34	2.6 ~ 3.5	19.0 ~ 25
12	44 ~ 61	4.5 ~ 6.2	33 ~ 45
14	73 ~ 98	7.4 ~ 10.0	54 ~ 72
16	115 ~ 155	11.5 ~ 16.0	83 ~ 115
18	165 ~ 225	17.0 ~ 23.0	125 ~ 165
20	225 ~ 325	23 ~ 33	165 ~ 240



**Suggest:**

**For more complete manuals. Please go to the home page.**

**<https://www.ebooklibonline.com>**

**If the above button click is invalid. Please download this document first, and then click the above link to download the complete manual.**

**Thank you so much for reading**

**Specifications**

Item	Standard	Service Limit
<b>Fuel System</b>		
Throttle Grip Free Play	2 ~ 3 mm (0.08 ~ 0.12 in.)	---
Hot Starter Lever Free Play	0.5 ~ 1.0 mm (0.02 ~ 0.04 in.)	---
Air Cleaner Element Oil	High quality foam air filter oil	---
<b>Cooling System</b>		
Coolant:		
Type (recommended)	Permanent type antifreeze	---
Color	Green	---
Mixed Ratio	Soft water 50% and coolant 50%	---
Freezing Point	-35 °C (-31 °F)	---
Total Amount	1.05 L (1.11 US qt)	---
<b>Engine Top End</b>		
Valve Clearance:		
Exhaust	0.17 ~ 0.22 mm (0.0067 ~ 0.0087 in.)	---
Inlet	0.10 ~ 0.15 mm (0.0039 ~ 0.0059 in.)	---
Cylinder Head Warp	---	0.05 mm (0.002 in.)
Cylinder Inside Diameter (see text)	96.000 ~ 96.012 mm (3.7795 ~ 3.7800 in.)	96.10 mm (3.783 in.)
Piston/Cylinder Clearance	0.020 ~ 0.042 mm (0.00079 ~ 0.0017 in.)	---
<b>Engine Right Side</b>		
Clutch Lever Free Play	8 ~ 13 mm (0.3 ~ 0.5 in.)	---
Friction Plate Thickness	2.92 ~ 3.08 mm (0.115 ~ 0.121 in.)	2.6 mm (0.10 in.)
Friction Plate Warp	0.15 mm (0.0059 in.) or less	0.3 mm (0.01 in.)
Steel Plate Warp	0.2 mm (0.008 in.) or less	0.3 mm (0.01 in.)
<b>Engine Lubrication System</b>		
Engine oil:		
Type	API SG, SH, SJ, SL or SM with JASO MA, MA1 or MA2	---
Viscosity	SAE 10W-30, 10W-40, or 10W-50	---
Capacity:		
Oil Change-When filter is not removed	1.06 L (1.12 US qt)	---
Oil Change-When filter is removed	1.08 L (1.14 US qt)	---
when engine is completely dry	1.3 L (1.4 US qt)	---
<b>Crankshaft/Transmission</b>		
Connecting Rod Big End Side Clearance	0.25 ~ 0.35 mm (0.0098 ~ 0.014 in.)	0.6 mm (0.02 in.)
<b>Wheels/Tires</b>		
Rim Runout:		
Axial	TIR 1.0 mm (0.039 in.) or less	TIR 2 mm (0.08 in.)
Radial	TIR 1.0 mm (0.039 in.) or less	TIR 2 mm (0.08 in.)
Front and Rear Tires Air Pressure	100 kPa (1.0 kgf/cm <sup>2</sup> , 14 psi)	---

## 2-10 PERIODIC MAINTENANCE

### Specifications

Item	Standard	Service Limit
Standard Tire:		
Front:		
Size	80/100-21 51M (AU) (EUR) 80/100-21 M/C 51P	--- ---
Make	BRIDGESTONE	---
Type	D401, Tube (AU) (EUR) ED03, Tube	--- ---
Rear:		
Size	110/100-18 64M (AU) (EUR) 120/90-18 M/C 65P	--- ---
Make	BRIDGESTONE	---
Type	M402, Tube (AU) (EUR) ED04, Tube	--- ---
<b>Final Drive</b>		
Drive Chain Slack	52 ~ 58 mm (2.0 ~ 2.3 in.)	---
Drive Chain 20 Link Length	317.5 ~ 318.2 mm (12.50 ~ 12.53 in.)	323 mm (12.7 in.)
Rear Sprocket Warp	0.4 mm (0.016 in.) or less	0.5 mm (0.020 in.)
<b>Brakes</b>		
Brake Lever Free Play	(to suit rider)	---
Brake Fluid:		
Type:		
Front	DOT3 or DOT4	---
Rear	DOT4	---
Brake pad lining thickness:		
Front	3.8 mm (0.15 in.)	1 mm (0.04 in.)
Rear	6.4 mm (0.25 in.)	1 mm (0.04 in.)
<b>Suspension</b>		
Fork Oil:		
Oil Viscosity	KHL15-10 (KAYABA 01) or equivalent	---
Oil Quantity:		(Adjustable range)
Outer (Outer/Inner Tubes)	335 mL (11.3 US oz.)	300 ~ 380 mL (10.1 ~ 12.8 US oz)
Inner (Subtank)	189 mL (6.4 US oz.)	---
<b>Electrical System</b>		
Spark Plug Gap	0.8 ~ 0.9 mm (0.03 ~ 0.04 in.)	---

TIR: Total Indicator Readings

**<https://www.ebooklibonline.com>**

Hello dear friend!

Thank you very much for reading.

Enter the link into your browser.

The full manual is available for immediate download.

**<https://www.ebooklibonline.com>**