

2005 TOURING MODELS

SERVICE MANUAL

Part Number 99483-05

Section 1: Maintenance
Section 2: Chassis
Section 3: Engine
Section 4: Fuel System
Section 5: Starter
Section 6: Drive
Section 7: Transmission
Section 8: Electrical
Section 9: Fuel Injection
Appendix

POLICE SERVICE SUPPLEMENT

Part Number 99483-05SP (FLT only)

Section 1: Maintenance
Section 2: Chassis
Section 3: Engine (No content)
Section 4: Fuel System (No content)
Section 5: Starter (No content)
Section 6: Drive (No content)
Section 7: Transmission (No content)
Section 8: Electrical
Section 9: Fuel Injection (No content)
Appendix

ELECTRICAL DIAGNOSTICS

Part Number 99495-05

Section 1: Starting & Charging
Section 2: Instruments
Section 3: TSM & TSSM
Section 4: Engine Management
Section 5: Engine Management (EFI)
Section 6: Sound System
Section 7: Cruise Control
Section 8: Wiring

FLHTCSE2 SERVICE SUPPLEMENT

Part Number 99500-05

Section 1: Maintenance
Section 2: Chassis
Section 3: Engine
Section 4: Fuel System (No content)
Section 5: Starter
Section 6: Drive
Section 7: Transmission
Section 8: Electrical
Section 9: Fuel Injection (No content)

SUBJECT	PAGE NO.
1.1 General	1-1
1.2 Maintenance Schedule	1-6
1.3 Engine Oil/Filter	1-9
1.4 Air Cleaner	1-11
1.5 Tires	1-13
1.6 Wheel Spokes	1-14
1.7 Primary Chain/Lubricant	1-15
1.8 Clutch Adjustment	1-17
1.9 Transmission Lubricant	1-19
1.10 Drive Belt	1-20
1.11 Throttle Cables	1-22
1.12 Enrichener Control	1-25
1.13 Fuel System	1-26
1.14 Brakes	1-28
1.15 Spark Plugs	1-29
1.16 Engine Idle Speed	1-30
1.17 Front Fork Oil	1-31
1.18 Steering Head Bearings	1-32
1.19 Critical Fasteners	1-33
1.20 Battery	1-35
1.21 Troubleshooting	1-36

REPAIR NOTES

General maintenance practices are given in this section. All special tools and torque values are noted at the point of use and all required parts or materials can be found in the appropriate PARTS CATALOG.

Safety

Safety is always the most important consideration when performing any job. Be sure you have a complete understanding of the task to be performed. Use common sense. Use the proper tools. Don't just do the job – do the job safely.

Removing Parts

Always consider the weight of a part when lifting. Use a hoist whenever necessary. Do not lift heavy parts by hand. A hoist and adjustable lifting beam or sling are needed to remove some parts. The lengths of chains or cables from the hoist to the part should be equal and parallel, and should be positioned directly over the center of the part. Be sure that no obstructions will interfere with the lifting operation. Never leave a part suspended in mid-air.

Always use blocking or proper stands to support the part that has been hoisted. If a part cannot be removed, verify that all bolts and attaching hardware have been removed. Check to see if any parts are in the way of the part being removed.

When removing hoses, wiring or tubes, always tag each part to ensure proper installation.

Cleaning

If you intend to reuse parts, follow good shop practice and thoroughly clean the parts before assembly. Keep all dirt out of parts; the unit will perform better and last longer. Seals, filters and covers are used in this motorcycle to keep out environmental dirt and dust. These items must be kept in good condition to ensure satisfactory operation.

Clean and inspect all parts as they are removed. Be sure all holes and passages are clean and open. After cleaning, cover all parts with clean lint-free cloth, paper or other material. Be sure the part is clean when it is installed.

Always clean around lines or covers before they are removed. Plug, tape or cap holes and openings to keep out dirt, dust and debris.

Always verify cleanliness of blind holes before assembly. Tightening screws with dirt, water or oil in the holes can cause castings to crack or break.

Disassembly and Assembly

Always assemble or disassemble one part at a time. Do not work on two assemblies simultaneously. Be sure to make all necessary adjustments. Recheck your work when finished. Be sure that everything is done.

Operate the motorcycle to perform any final check or adjustments. If all is correct, the motorcycle is ready to go back to the customer.

Checking Torques on Fasteners with Lock Patches

To check the torque on a fastener that has a lock patch:

1. Set the torque wrench for the lowest setting in the specified torque range.
2. Attempt to tighten fastener to set torque. If fastener does not move and lowest setting is satisfied (torque wrench clicks), then the proper torque has been maintained.

REPAIR AND REPLACEMENT PROCEDURES

Hardware and Threaded Parts

Install helical thread inserts when inside threads in castings are stripped, damaged or not capable of withstanding specified torque.

Replace bolts, nuts, studs, washers, spacers and small common hardware if missing or in any way damaged. Clean up or repair minor thread damage with a suitable tap or die.

Replace all damaged or missing lubrication fittings.

Use Teflon tape on pipe fitting threads.

Wiring, Hoses and Lines

Replace hoses, clamps, electrical wiring, electrical switches or fuel lines if they do not meet specifications.

Instruments and Gauges

Replace broken or defective instruments and gauges. Replace dials and glass that are so scratched or discolored that reading is difficult.

<https://www.ebooklibonline.com>

Hello dear friend!

Thank you very much for reading.

Enter the link into your browser.

The full manual is available for immediate download.

<https://www.ebooklibonline.com>

Bearings

Anti-friction bearings must be handled in a special way. To keep out dirt and abrasives, cover the bearings as soon as they are removed from the package.

Wash bearings in a non-flammable cleaning solution. Knock out packed lubricant inside by tapping the bearing against a wooden block. Wash bearings again. Cover bearings with clean material after setting them down to dry. Never use compressed air to dry bearings.

Coat bearings with clean oil. Wrap bearings in clean paper.

Be sure that the chamfered side of the bearing always faces the shoulder (when bearings installed against shoulders). Lubricate bearings and all metal contact surfaces before pressing into place. Only apply pressure on the part of the bearing that makes direct contact with the mating part.

Always use the proper tools and fixtures for removing and installing bearings.

Bearings do not usually need to be removed. Only remove bearings if necessary.

Bushings

Do not remove a bushing unless damaged, excessively worn or loose in its bore. Press out bushings that must be replaced.

When pressing or driving bushings, be sure to apply pressure in line with the bushing bore. Use a bearing/bushing driver or a bar with a smooth, flat end. Never use a hammer to drive bushings.

Inspect the bushing and the mated part for oil holes. Be sure all oil holes are properly aligned.

Gaskets

Always discard gaskets after removal. Replace with new gaskets. Never use the same gasket twice (unless instructed otherwise). Be sure that gasket holes match up with holes in the mating part.

If a gasket must be made, be sure to cut holes that match up with the mating part. Serious damage can occur if any flange holes are blocked by the gasket. Use material that is the right type and thickness.

Lip Type Seals

Lip seals are used to seal oil or grease and are usually installed with the sealing lip facing the contained lubricant. Seal orientation, however, may vary under different applications.

Seals should not be removed unless necessary. Only remove seals if required to gain access to other parts or if seal damage or wear dictates replacement.

Leaking oil or grease usually means that a seal is damaged. Replace leaking seals to prevent overheated bearings.

Always discard seals after removal. Do not use the same seal twice.

O-Rings (Preformed Packings)

Always discard O-rings after removal. Replace with new O-rings. To prevent leaks, lubricate the O-rings before installation. Apply the same type of lubricant as that being sealed. Be sure that all gasket, O-ring and seal mating surfaces are thoroughly clean before installation.

Gears

Always check gears for damaged or worn teeth.

Remove burrs and rough spots with a honing stone or crocus cloth before installation. Lubricate mating surfaces before pressing gears on shafts.

Shafts

If a shaft does not come out easily, check that all nuts, bolts or retaining rings have been removed. Check to see if other parts are in the way before using force.

Shafts fitted to tapered splines should be very tight. If shafts are not tight, disassemble and inspect tapered splines. Discard parts that are worn. Be sure tapered splines are clean, dry and free of burrs before putting them in place. Press mating parts together tightly.

Clean all rust from the machined surfaces of new parts.

Part Replacement

Always replace worn or damaged parts with new parts.

CLEANING

Part Protection

Before cleaning, protect rubber parts (such as hoses, boots and electrical insulation) from cleaning solutions. Use a grease-proof barrier material. Remove the rubber part if it cannot be properly protected.

Cleaning Process

Any cleaning method may be used as long as it does not result in parts damage. Thorough cleaning is necessary for proper parts inspection. Strip rusted paint areas to bare metal before repainting.

Rust or Corrosion Removal

Remove rust and corrosion with a wire brush, abrasive cloth, sand blasting, vapor blasting or rust remover. Use buffing crocus cloth on highly polished parts that are rusted.

Bearings

Remove shields and seals from bearings before cleaning. Clean bearings with permanent shields and seals in solution.

Clean open bearings by soaking them in a petroleum cleaning solution. Never use a solution that contains chlorine.

Let bearings stand and dry. Do not dry using compressed air. Do not spin bearings while they are drying.

TOOL SAFETY

AIR TOOLS

- Always use approved eye protection equipment when performing any task using air-operated tools.
- On all power tools, use only recommended accessories with proper capacity ratings.
- Do not exceed air pressure ratings of any power tools.
- Bits should be placed against work surface before air hammers are operated.
- Disconnect the air supply line to an air hammer before attaching a bit.
- Never point an air tool at yourself or another person.
- Protect bystanders with approved eye protection.

WRENCHES

- Never use an extension on a wrench handle.
- If possible, always pull on a wrench handle and adjust your stance to prevent a fall if something lets go.
- Never cock a wrench.
- Never use a hammer on any wrench other than a Striking Face wrench.
- Discard any wrench with broken or battered points.
- Never use a pipe wrench to bend, raise, or lift a pipe.

PLIERS/CUTTERS/PRYBARS

- Plastic or vinyl covered pliers handles are not intended to act as insulation; don't use on live electrical circuits.
- Don't use pliers or cutters for cutting hardened wire unless they were designed for that purpose.
- Always cut at right angles.
- Don't use any prybar as a chisel, punch, or hammer.

HAMMERS

- Never strike one hammer against a hardened object, such as another hammer.
- Always grasp a hammer handle firmly, close to the end.
- Strike the object with the full face of the hammer.
- Never work with a hammer which has a loose head.
- Discard hammer if face is chipped or mushroomed.
- Wear approved eye protection when using striking tools.
- Protect bystanders with approved eye protection.

PUNCHES/CHISELS

- Never use a punch or chisel with a chipped or mushroomed end; dress mushroomed chisels and punches with a file.
- Hold a chisel or a punch with a tool holder if possible.
- When using a chisel on a small piece, clamp the piece firmly in a vise, and chip toward the stationary jaw.
- Wear approved eye protection when using these tools.
- Protect bystanders with approved eye protection.

SCREWDRIVERS

- Don't use a screwdriver for prying, punching, chiseling, scoring, or scraping.
- Use the right type of screwdriver for the job; match the tip to the fastener.
- Don't interchange POZIDRIV®, PHILLIPS®, or REED AND PRINCE screwdrivers.
- Screwdriver handles are not intended to act as insulation; don't use on live electrical circuits.
- Don't use a screwdriver with rounded edges because it will slip – redress with a file.

RATCHETS AND HANDLES

- Periodically clean and lubricate ratchet mechanisms with a light grade oil. Do not replace parts individually; ratchets should be rebuilt with the entire contents of service kit.
- Never hammer or put a pipe extension on a ratchet or handle for added leverage.
- Always support the ratchet head when using socket extensions, but do not put your hand on the head or you may interfere with the action of its reversing mechanism.
- When breaking loose a fastener, apply a small amount of pressure as a test to be sure the ratchet's gear wheel is engaged with the pawl.

SOCKETS

- Never use hand sockets on power or impact wrenches.
- Select the right size socket for the job.
- Never cock any wrench or socket.
- Select only impact sockets for use with air or electric impact wrenches.
- Replace sockets showing cracks or wear.
- Keep sockets clean.
- Always use approved eye protection when using power or impact sockets.

STORAGE UNITS

- Don't open more than one loaded drawer at a time. Close each drawer before opening up another.
- Close lids and lock drawers and doors before moving storage units.
- Don't pull on a tool cabinet; push it in front of you.
- Set the brakes on the locking casters after the cabinet has been rolled to your work.

MAINTENANCE SCHEDULE

1.2

The table below lists the maintenance requirements for Touring models. If you are familiar with the procedures, just refer to the table for the recommended service interval. If necessary, see the quick reference table on the next page for the

required specifications. If more detailed information is needed, turn to the sections which follow for step-by-step instructions.

Table 1-1. Scheduled Maintenance Intervals

ITEM	PROCEDURE	1000 mi	5000 mi	10,000 mi	15,000 mi	20,000 mi	25,000 mi	NOTES
		1600 km	8000 km	16,000 km	24,000 km	32,000 km	40,000 km	
Engine oil and filter	Replace	X	X	X	X	X	X	
Oil lines and brake system	Inspect for leaks	X	X	X	X	X	X	1
Air cleaner	Inspect, service as required	X	X	X	X	X	X	
Tires	Check pressure, inspect tread	X	X	X	X	X	X	
Wheel spokes	Check tightness	X	X			X		1, 4
Primary chain tension	Check adjustment	X	X	X	X	X	X	
Primary chaincase lubricant	Replace	X	X	X	X	X	X	
Clutch	Check adjustment	X	X	X	X	X	X	1
Transmission lubricant	Replace	X	X	X	X	X	X	
Drive belt and sprockets	Inspect, adjust belt	X	X	X	X	X	X	1
Throttle, brake, clutch and enricher controls	Check, adjust and lubricate	X	X	X	X	X	X	1, 4
Jiffy stand	Inspect and lubricate	X		X		X		1
Fuel valve, lines and fittings	Inspect for leaks	X	X	X	X	X	X	1, 4
Fuel filter	Clean (EFI: replace)						X	1
Brake fluid	Check levels and condition	X	X	X	X	X	X	
Brake pads and discs	Inspect for wear	X	X	X	X	X	X	
Spark plugs	Inspect	X	X		X		X	
	Replace			X		X		
Electrical equipment and switches	Check operation	X	X	X	X	X	X	
Engine idle speed	Check adjustment	X	X	X	X	X	X	1
Front fork oil	Replace					X		1
Steering head bearings	Adjust and lubricate	X		X		X		1, 2
Windshield bushings	Inspect			X		X		1
Fuel door, Tour-pak, saddlebags	Lubricate hinges and latches	X	X	X	X	X		
Critical fasteners	Check tightness	X		X		X		1
Engine mounts and stabilizer links	Inspect			X		X		1
Battery	Check battery and clean connections							3
Road test	Verify component and system functions	X	X	X	X	X	X	

NOTES:

- Should be performed by an authorized Harley-Davidson dealer, unless you have the proper tools, service data and are mechanically qualified.
- Disassemble, lubricate and inspect every 30,000 miles (48,000 km).
- Perform annually.
- Not all vehicles are equipped with enricher, fuel valve or spoke wheels.

Table 1-2. Quick Reference Data

ITEM	SPECIFICATION	DATA
Engine oil and filter	Drain plug torque	14-21 ft-lbs (19-28 Nm)
	Oil capacity	4 qt. (3.8 L)
	Filter	Hand tighten 1/2-3/4 turn after gasket contact
	Chrome filter part number	63798-99
	Black filter part number	63731-99
Air cleaner	Air cleaner cover bracket screw torque	20-40 in-lbs (2-5 Nm)
	Air cleaner cover screw torque	36-60 in-lbs (4-7 Nm)
	Air cleaner cover screw threadlocker	Loctite Medium Strength Threadlocker 243 (blue), Part No. 99642-97 (6 ml)
Tire condition and pressure	Pressure: solo rider	Front: 36 psi (2.5 bar), Rear: 36 psi (2.5 bar)
	Pressure: rider with passenger	Front: 36 psi (2.5 bar), Rear: 40 psi (2.8 bar)
	Wear	Replace tire if 1/32 in. (0.8 mm) or less of tread pattern remains
Wheel spokes	Spoke nipple torque	40-50 in-lbs (4.5-5.6 Nm)
Primary chain tension	Deflection with engine cold	5/8-7/8 in. (15.9-22.2 mm)
	Deflection with engine hot	3/8-5/8 in. (9.5-15.9 mm)
	Chain tensioner nut torque	21-29 ft-lbs (29-39 Nm)
	Primary chain inspection cover torque	84-108 in-lbs (10-12 Nm)
Primary chaincase lubricant	Lubricant capacity	32 oz (946 mL)
	Primary chaincase drain plug torque	36-60 in-lbs (4-7 Nm)
	<i>Primary Chaincase Lubricant</i> part numbers	99887-84 (qt), 99886-84 (gal)
Clutch adjustment	Free play at adjuster screw	1/2-1 turn
	Free play at hand lever	1/16-1/8 in. (1.6-3.2 mm)
	Adjuster screw locknut torque	72-120 in-lbs (8-14 Nm)
	Clutch inspection cover torque	84-108 in-lbs (10-12 Nm)
Transmission lubricant	Lubricant level	Dipstick at FULL with motorcycle level and filler plug resting on threads
	Lubricant capacity	20-24 oz (590-710 mL)
	<i>Semi-Synthetic Transmission Lubricant</i> part numbers	99892-84 (qt), 99853-96 (case of qt's) 99891-84 (gal), 99852-96 (case of gal's)
	Transmission drain plug torque	14-21 ft-lbs (19-28 Nm)
	Filler plug torque	25-75 in-lbs (3-9 Nm)
Drive belt	Upward force at midpoint of bottom belt strand	10 lb. (4.5 kg)
	Deflection with motorcycle on jiffy stand without rider or luggage and 10 psi (69 kPa) in rear shocks	1/4 - 5/16 in. (6.4-7.9 mm)
	Deflection with motorcycle upright and rear wheel in the air	3/16 - 1/4 in. (4.8-6.4 mm)
Throttle and clutch cables	Lubricant part number	<i>Super Oil</i> , 94968-85TV (1/4 fl. oz)
	Handlebar clamp screw torque	60-80 in-lbs (6.8-9.0 Nm)
	Handlebar switch housing screw torque	35-45 in-lbs (4-5 Nm)
Enrichener control	Hex nut torque	20-35 in-lbs (2-4 Nm)
Fuel filter	Hex jam nut torque	15-20 ft-lbs (20-27 Nm)
Brake Fluid Reservoir Level	<i>DOT 4 Brake Fluid</i> part number	99953-99A (12 oz)
	Level	1/8 inch (3.2 mm) from the top
	Master cylinder reservoir cover torque	6-8 in-lbs (0.7-0.9 Nm)
Brake pad linings and discs	Minimum brake pad thickness	0.04 in. (1.02 mm)
	Minimum brake disc thickness	See stamp on side of disc

Table 1-2. Quick Reference Data

ITEM	SPECIFICATION	DATA
Spark plugs	Type	HD-6R12
	Gap	0.038-0.043 in. (0.97-1.09 mm)
	Torque	12-18 ft-lbs (16-24 Nm)
Engine idle speed	Idle speed	950-1050 rpm
Front Fork Oil	<i>Hydraulic Fork Oil (Type E)</i> part number	99884-80 (16 oz)
	Amount	See Section 2.15
Steering head bearings	Neck fitting lubricant	<i>Special Purpose Grease</i> , 99857-97 (14 oz cartridge)
Critical fasteners, engine mounts and stabilizer links	See Section 1.19	
Battery	Lubricant part number	<i>Electrical Contact Lubricant</i> , 99861-02 (1 oz)
	Terminal bolt torque	60-96 in-lbs (6.8-10.9 Nm)
	Hold-down clamp screw torque	15-20 ft-lbs (20-27 Nm)

SUBJECT	PAGE NO.
2.1 Specifications	2-1
2.2 Vehicle Identification Number (V.I.N.)	2-5
2.3 Front Wheel	2-6
2.4 Rear Wheel	2-11
2.5 Checking Rim Runout	2-17
2.6 Wheel Lacing—16 Inch Rim	2-18
2.7 Truing Laced Wheel	2-21
2.8 Tires And Tubes	2-23
2.9 Vehicle Alignment	2-27
2.10 Front Brake Master Cylinder	2-33
2.11 Rear Brake Master Cylinder	2-38
2.12 Front Brake Caliper	2-46
2.13 Rear Brake Caliper	2-53
2.14 Bleeding Hydraulic Brake System	2-59
2.15 Front Forks	2-61
2.16 Lower Fork Bracket Cover/Air Dam	2-71
2.17 Steering Head Bearings	2-72
2.18 Rear Air Suspension	2-76
2.19 Rear Shock Absorbers	2-81
2.20 Rear Swingarm	2-83
2.21 Throttle Cables (Non-Cruise)	2-90
2.22 Clutch Cable	2-95
2.23 Handlebars	2-99
2.24 Seat	2-103
2.25 Saddlebag	2-107
2.26 Tour-Pak	2-114
2.27 Tour-Pak Lights/Backrest/Speaker Box	2-117
2.28 Lower Fairing/Engine Guard	2-121
2.29 Upper Fairing/Windshield (FLHT/C/U)	2-123
2.30 Upper Fairing/Windshield (FLTR)	2-131
2.31 Windshield/Headlamp Nacelle (FLHR/C/S)	2-141
2.32 Front Fender	2-145
2.33 Rear Fender	2-147
2.34 Jiffy Stand	2-150
2.35 Footboards/Footrests	2-152
2.36 Exhaust System	2-156

DIMENSIONS (IN.)

	FLHT/C/U	FLHR/C/S	FLTR
Wheel Base	63.5	63.5	63.5
Overall Length	93.7/97.5/98.3	93.7	93.7
Overall Width	39.0	34.45/34.45/39.40	35.75
Road Clearance	5.12	5.12/5.12/4.70	5.12
Overall Height	61.0	55.06/55.06/46.40	55.0
Saddle Height*	27.3	27.3/26.9/26.1	26.9

* With 180 Lb. Rider

DIMENSIONS (MM)

	FLHT/C/U	FLHR/C/S	FLTR
Wheel Base	1613	1613	1613
Overall Length	2380/2476/2497	2380	2380
Overall Width	990	875/875/1001	908
Road Clearance	130	130/130/119	130
Overall Height	1549	1399/1399/1179	1397
Saddle Height*	693	693/683/663	683

* With 81.6 kg Rider

WEIGHT (LBS.)

	FLHT/C/U	FLHR/C/S	FLTR
DRY WEIGHT**	758/776/788	723/710/721	731
GVWR	1259	1259	1259
GAWR – Front	500	500	500
GAWR – Rear	827	827	827

** As shipped from the factory

WEIGHT (KG)

	FLHT/C/U	FLHR/C/S	FLTR
DRY WEIGHT**	344/352/358	328/322/327	332
GVWR	571	571	571
GAWR – Front	227	227	227
GAWR – Rear	375	375	375

** As shipped from the factory

NOTE

Gross Vehicle Weight Rating (GVWR) (maximum allowable loaded vehicle weight) and corresponding Gross Axle Weight Ratings (GAWR) are given on a label located on the inside of the right front frame downtube.

CAPACITIES (U.S.)

	FLHT/C/U	FLHR/C/S	FLTR
Fuel Tank (gallons) Total*** Reserve	5 0.9	5 0.9	5 0.9
Oil Tank (quarts) with filter	4	4	4
Transmission (Ounces, approximate)	20-24	20-24	20-24
Primary Chaincase (Ounces, approximate)	32	32	32
Front Fork (Ounces)	Left 10.0 Right 11.1	Left 11.1 Right 11.1	Left 10.0 Right 11.1

*** Includes Reserve on Carbureted Models

CAPACITIES (METRIC)

	FLHT/C/U	FLHR/C/S	FLTR
Fuel Tank (liters) Total*** Reserve	18.9 3.4	18.9 3.4	18.9 3.4
Oil Tank (liters) with filter	3.78	3.78	3.78
Transmission (Milliliters)	591-710	591-710	591-710
Primary Chaincase (Milliliters)	946	946	946
Front Fork (Milliliters)	Left 295 Right 328	Left 328 Right 328	Left 295 Right 328

*** Includes Reserve on Carbureted Models

TIRE DATA

WARNING

Tires, rims and air valves must be correctly matched to wheel rims. See your Harley-Davidson dealer for service. Mismatching tires, tubes, rims and air valves may result in damage to the tire bead during mounting or may allow the tire to slip on the rim, possibly causing tire failure, which could result in death or serious injury.

WARNING

Using tires in ways other than those specified below may adversely affect motorcycle stability. Instability may lead to loss of vehicle control, which could result in death or serious injury.

- Use tubeless tires on all Harley-Davidson cast and disc wheels.
- Tubeless tires fitted with the correct size inner tubes also may be used on all Harley-davidson laced wheels, but protective rubber rim strips must be installed to prevent damage to the inner tubes.
- Do not use inner tubes in radial tires. Do not use radial tires on laced wheels.
- Always use the correct size tires and tubes. Tire sizes are molded on the tire sidewall. Tube sizes are printed on the tube.

WARNING

Maximum inflation pressure must not exceed specification on tire sidewall. Exceeding inflation specifications can adversely affect handling or result in tire failure, which could result in death or serious injury.

Dunlop Tires Only	Tire Pressure (Cold)			
	Front		Rear	
	PSI	BARS	PSI	BARS
Solo Rider	36	2.5	36	2.5
Rider & One Passenger	36	2.5	40	2.8

REAR WHEEL SPROCKET

70 teeth

TORQUE VALUES

Item	ft/in-lbs	Nm
Front brake disc TORX screws	16-24 ft-lbs	22-33 Nm
Front axle nut	50-55 ft-lbs	68-75 Nm
Front axle holder nuts	132-180 in-lbs	14.9-20.3 Nm
Front brake caliper mounting bolts	28-38 ft-lbs	37.9-51.5 Nm
Rear brake disc TORX screws	30-45 ft-lbs	41-61 Nm
Rear wheel sprocket bolts	55-65 ft-lbs	75-88 Nm
Rear axle cone nut	95-105 ft-lbs	129-142 Nm
Wheel spokes	40-50 in-lbs	4.5-5.6 Nm
Front engine mount to frame bolts	15-20 ft-lbs	20-27 Nm
Front engine mounting bracket to rubber mount bolt	15-20 ft-lbs	20-27 Nm
Voltage regulator locknuts	70-100 in-lbs	7.9-11.3 Nm
Handlebar clamp to master cylinder housing TORX screws	60-80 in-lbs	6.8-9.0 Nm
Brake caliper bleeder valve	80-100 in-lbs	9.0-11.3 Nm
Rear brake pedal shaft locknut	15-20 ft-lbs	20-27 Nm
Brake pedal/master cylinder assembly to mounting bracket hex nut	30-40 ft-lbs	41-54 Nm
Banjo bolt to master cylinder	17-22 ft-lbs	23-30 Nm
Banjo bolt to brake caliper	17-22 ft-lbs	23-30 Nm
Fairing lower U-bolt retainer locknuts	35-40 in-lbs	4.0-4.5 Nm
Fairing lower to engine guard clamp TORX screw	90-100 in-lbs	10.2-11.3 Nm
Fairing lower cap screws	10-15 in-lbs	1.1-1.7 Nm
Front brake master cylinder reservoir cover screws	6-8 in-lbs	0.7-0.9 Nm
Rear brake master cylinder reservoir cover screws	6-8 in-lbs	0.7-0.9 Nm
Brake caliper pad pins	180-200 in-lbs	20-23 Nm
Brake caliper bridge bolts	28-38 ft-lbs	38-52 Nm
Continued ...		

TORQUE VALUES (CONT'D)

Item	ft/in-lbs	Nm
Fork oil drain plugs	72-96 in-lbs	8-11 Nm
Fork pinch bolts	30-35 ft-lbs	41-48 Nm
Fork stem nut	60-80 ft-lbs	81-109 Nm
Fork tube plug	22-58 ft-lbs	30-79 Nm
Fork cap bolt	50-60 ft-lbs	68-81 Nm
Damper rod/cartridge 6mm screw	132-216 in-lbs	14.9-24.4 Nm
Damper rod locknut (cartridge type fork)	13-20 ft-lbs	18-27 Nm
Shock bottom mounting bolt	35-40 ft-lbs	47-54 Nm
Shock top mounting bolt	33-35 ft-lbs	45-48 Nm
Rear swingarm bracket bolts	34-42 ft-lbs	46-57 Nm
Rear swingarm pivot shaft locknut	40-45 ft-lbs	54-61 Nm
Handlebar switch housing TORX screws	35-45 in-lbs	4-5 Nm
Handlebar clamp to clutch lever bracket screws	60-80 in-lbs	6.8-9.0 Nm
Clutch release cover socket head screws	84-132 in-lbs	9.5-14.9 Nm
Clutch cable fitting	36-60 in-lbs	4-7 Nm
Transmission lubricant drain plug	14-21 ft-lbs	19-28 Nm
Transmission filler plug/ dipstick	25-75 in-lbs	2.8-8.5 Nm
Battery cable bolt	60-96 in-lbs	6.8-10.9 Nm
Tour-Pak mounting bolts	96-120 in-lbs	10.8-13.5 Nm
Inner fairing screws	20-30 in-lbs	2.3-3.4 Nm
Outer fairing screws (below windshield)	25-30 in-lbs	2.8-3.4 Nm
Fairing cap TORX screws	25-30 in-lbs	2.8-3.4 Nm
Speedometer/tachometer bracket socket screws	10-20 in-lbs	1.1-2.3 Nm
2 inch diameter gauge nuts	10-20 in-lbs	1.1-2.3 Nm
Auxiliary lamp bracket to fork bracket TORX bolts	15-20 ft-lbs	20-27 Nm
Windshield wellnut screws (FLTR)	6-13 in-lbs	0.7-1.5 Nm
Front turn signal lamp bracket stud acorn nuts (FLTR)	40-50 in-lbs	4.5-5.7 Nm
Continued ...		

Item	ft/in-lbs	Nm	
Short fairing screws (FLTR)	6-12 in-lbs	0.7-1.4 Nm	
Long fairing screws (FLTR)	10-15 in-lbs	1.1-1.7 Nm	
Instrument bezel TORX screws (FLTR)	25-35 in-lbs	2.8-4.0 Nm	
Instrument nacelle to fork bracket TORX bolts (FLTR)	15-20 ft-lbs	20-27 Nm	
Fairing bracket/steering head thru bolt (FLTR)	20-30 ft-lbs	27.1-40.7 Nm	
Radio bracket/inner fairing to fairing bracket stud lock- nuts (FLTR)	96-144 in-lbs	10.9-16.3 Nm	
Headlamp nacelle handle- bar clamp shroud Phillips screw	10-20 in-lbs	1.1-2.3 Nm	
Headlamp nacelle trim strip flange nut	15-20 in-lbs	1.7-2.3 Nm	
Auxiliary lamp bracket to fork bracket stud acorn nuts	72-108 in-lbs	8.1-12.2 Nm	
Front fender mounting bolts	16-20 ft-lbs	22-27 Nm	
Rear fender TORX bolts	15-20 ft-lbs	20-27 Nm	
Jiffy stand leg stop flange nut	43-53 ft-lbs	58-72 Nm	
Intake flange adapter screws	96-144 in-lbs	10.9-16.3 Nm	
Exhaust flange adapter nuts	100-120 in-lbs	11.3-13.6 Nm	
Exhaust pipe TORCA clamps	45-60 ft-lbs	61-81 Nm	
Heat shield worm drive clamps	20-40 in-lbs	2.3-4.5 Nm	
Transmission exhaust bracket clamp bolt	60-96 in-lbs	6.8-10.8 Nm	
Passenger footboard/ footrest socket screws	15-18 ft-lbs	20-24 Nm	
Rider footboard pivot bolt nut	84-108 in-lbs	9.5-12.2 Nm	
Air valve mount hex nut	40-50 in-lbs	4.5-5.6 Nm	
Handlebar upper clamp screws	12-16 ft-lbs	16.3-21.7 Nm	
Handlebar lower clamp bolts (risers)	30-40 ft-lbs	40.7-54.2 Nm	
Ignition switch nut	DOM	50-70 in-lbs	5.7-7.9 Nm
	HDI	125-150 in-lbs	14.1-16.9 Nm
Speaker box to Tour-Pak bolts	25-35 in-lbs	2.8-4.0 Nm	
Throttle cable J-clamp screw to wellnut (FLHR/C)	9-18 in-lbs	1.0-2.0 Nm	

NOTES

VEHICLE IDENTIFICATION NUMBER (V.I.N.)

See [Figure 2-1](#). The full 17-digit serial number, or Vehicle Identification Number (V.I.N.), is stamped on the right side of the frame backbone at the rear of the steering head (and under the main harness conduit). A label bearing the V.I.N. code is also affixed to the left side of the steering head. An abbreviated V.I.N. is stamped between the front and rear cylinders on the left side of the crankcase.

Sample V.I.N. as it appears on the steering head – **1HD1DJV135Y110000**

Sample abbreviated V.I.N. as it appears on the crankcase – **DJV5110000**

NOTE

Always give the complete V.I.N. when ordering parts or making an inquiry about your motorcycle.

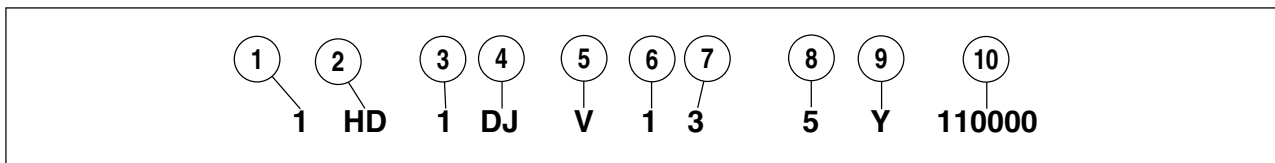

Figure 2-1. Vehicle Identification Number (V.I.N.)

Table 2-1. V.I.N. Description

ITEM	DESCRIPTION	VALUE
1	Market destination	1=Domestic 5=International
2	Manufacturer	HD=Harley-Davidson
3	Motorcycle type	1=Heavyweight
4	Model designation	See Table 2-2 .
5	Engine type	V=Carbureted W=Fuel injected
6	Introduction	1=Regular 2=Mid-year 3=California 4=Anniversary
7	V.I.N. check digit	Can be 0-9 or X
8	Model year	5=2005
9	Assembly plant	K=Kansas City, MO Y=York, PA
10	Sequential number (last 6 digits)	Varies

Table 2-2. Model Designation

CODE	MODEL	CODE	MODEL
DD	FLHT	FL	FLHTCUI Shrine
DJ	FLHTC	FR	FLHRCI
FB	FLHRI	FS	FLTRI
FC	FLHTCUI	FV	FLHTI
FD	FLHR	FW	FLHRI Shrine
FF	FLHTCI	FX	FLHRS
FG	FLHTCUI W/SC	FY	FLHRSI
FK	FLHTCI Shrine		

GENERAL

Maximum tire mileage and good handling qualities are directly related to care given wheels and tires. Wheels and tires should be regularly inspected for wear. If handling problems occur, see Section 1.21 TROUBLESHOOTING, HANDLING, for possible causes.

Always keep tires inflated to the recommended pressure and balance the wheel whenever a tire or tube is replaced.

PRELIMINARY INSPECTION

1. Measure brake disc thickness for excessive wear. Minimum acceptable thickness is stamped on side of disc. Also replace discs if warped or badly scored. Obtain **new** T40 TORX screws if brake discs were removed.
2. Whenever the wheel is removed for tire replacement or any other purpose, inspect the wheel bearings as follows:
 - a. Insert finger into wheel bearing and rotate the inner race in both directions. Repeat step on opposite side of wheel.
 - b. Replace the wheel bearings if there is rough rotation, abnormal noise or anything unusual. Always replace wheel bearings as a set. Never replace just one wheel bearing.

REMOVAL

1. Use shop rag or tape to protect fender area adjacent to caliper, as incidental contact can occur during caliper removal.



Figure 2-2. Inspect Wheel Bearings

2. Remove both the upper and lower mounting bolts from lugs of front fork leg to release brake caliper assembly.
3. Lift caliper upward to remove from brake disc. Allow the caliper to hang loose.
4. Repeat steps 1 thru 3 to release caliper on opposite side of wheel.

NOTE

Do not operate the front brake hand lever with the front wheel removed or the caliper pistons may be forced out. Reseating pistons requires disassembly of the caliper.

5. Insert screwdriver or steel rod through hole in axle on right side of vehicle. While holding axle stationary, remove the axle nut, lockwasher and flat washer on the left side.
6. Loosen the two axle holder nuts at bottom of right side fork leg.
7. With soft mallet, tap axle toward right side of vehicle until loose. Catching external spacers on left and right side, pull axle from hub while supporting wheel.
8. Move wheel to bench area and inspect bearings. See [PRELIMINARY INSPECTION](#) on this page.

DISASSEMBLY

1. If wheel bearing replacement is necessary, proceed as follows:
 - a. Obtain the WHEEL BEARING REMOVER/INSTALLER (HD-44060). Pick out the wheel bearing remover tools for the front wheel. See [Figure 2-3](#).
 - b. To prolong service life and ensure smooth operation, sparingly apply graphite lubricant to threads of forcing screw.
 - c. Install hex nut, flat washer and Nice bearing on forcing screw. Insert end of forcing screw through hole in bridge.
 - d. Install steel ball inside **larger** collet. Install collet at end of forcing screw.
 - e. Insert collet into bearing ID. Feel for inside edge of bearing using lip at end of collet and then back off slightly.
 - f. Holding forcing screw to prevent rotation, turn hex on collet until lip makes firm contact with inside edge of bearing. See upper frame of [Figure 2-4](#).

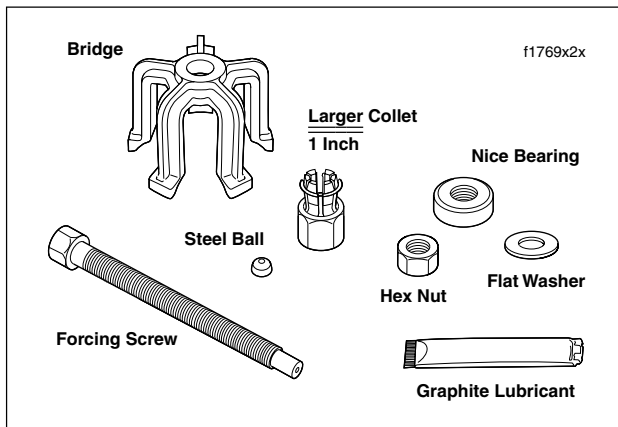

**Figure 2-3. Front Wheel Bearing Remover Tools
(Part No. HD-44060)**

- g. Holding forcing screw, turn hex nut until bearing is free. See lower frame of [Figure 2-4](#).
 - h. Remove spacer sleeve from wheel hub.
 - i. Repeat procedure to remove bearing on opposite side of wheel. Discard bearings.
2. If brake disc replacement is necessary, use a T40 TORX drive head and remove five screws securing brake disc to hub. Discard TORX screws. Repeat procedure to remove disc on opposite side of wheel. If the wheel is to be assembled with the same discs, mark both the wheel and discs, so that they can be installed in their original positions.
 3. If tire replacement is necessary, see Section 2.8 [TIRES AND TUBES](#).
 4. If the wheel is laced, and hub, spoke or rim replacement is necessary, loosen all spoke nipples and disassemble hub from rim.

CLEANING AND INSPECTION

1. Thoroughly clean all parts in solvent.
2. Inspect all parts for damage or excessive wear.
3. Always replace bearing assemblies as a complete set.
4. Inspect brake discs. Replace discs if warped or badly scored. Measure disc thickness for excessive wear. Minimum acceptable thickness is stamped on side of disc.

ASSEMBLY

1. On laced wheels, if the hub and rim were disassembled, assemble the hub, spokes and rim. See Section 2.6 [WHEEL LACING-16 INCH RIM](#).

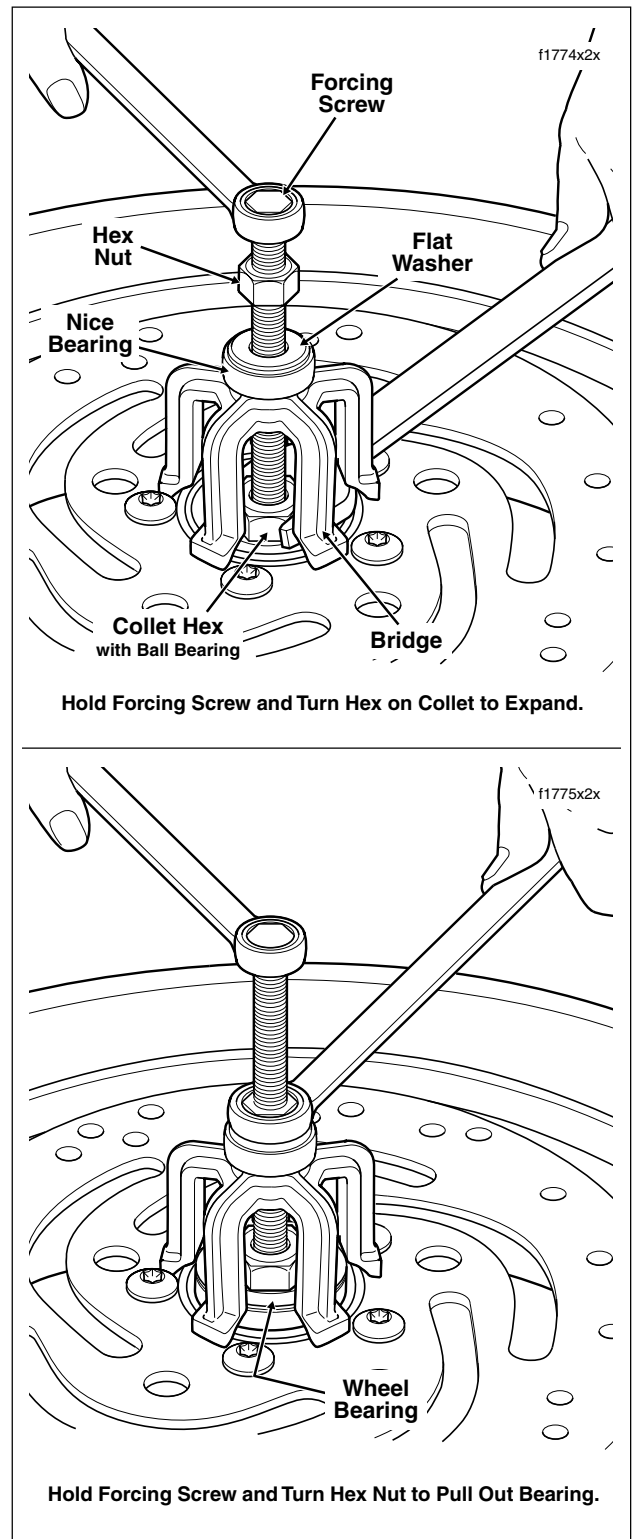

Figure 2-4. Remove Sealed Wheel Bearings

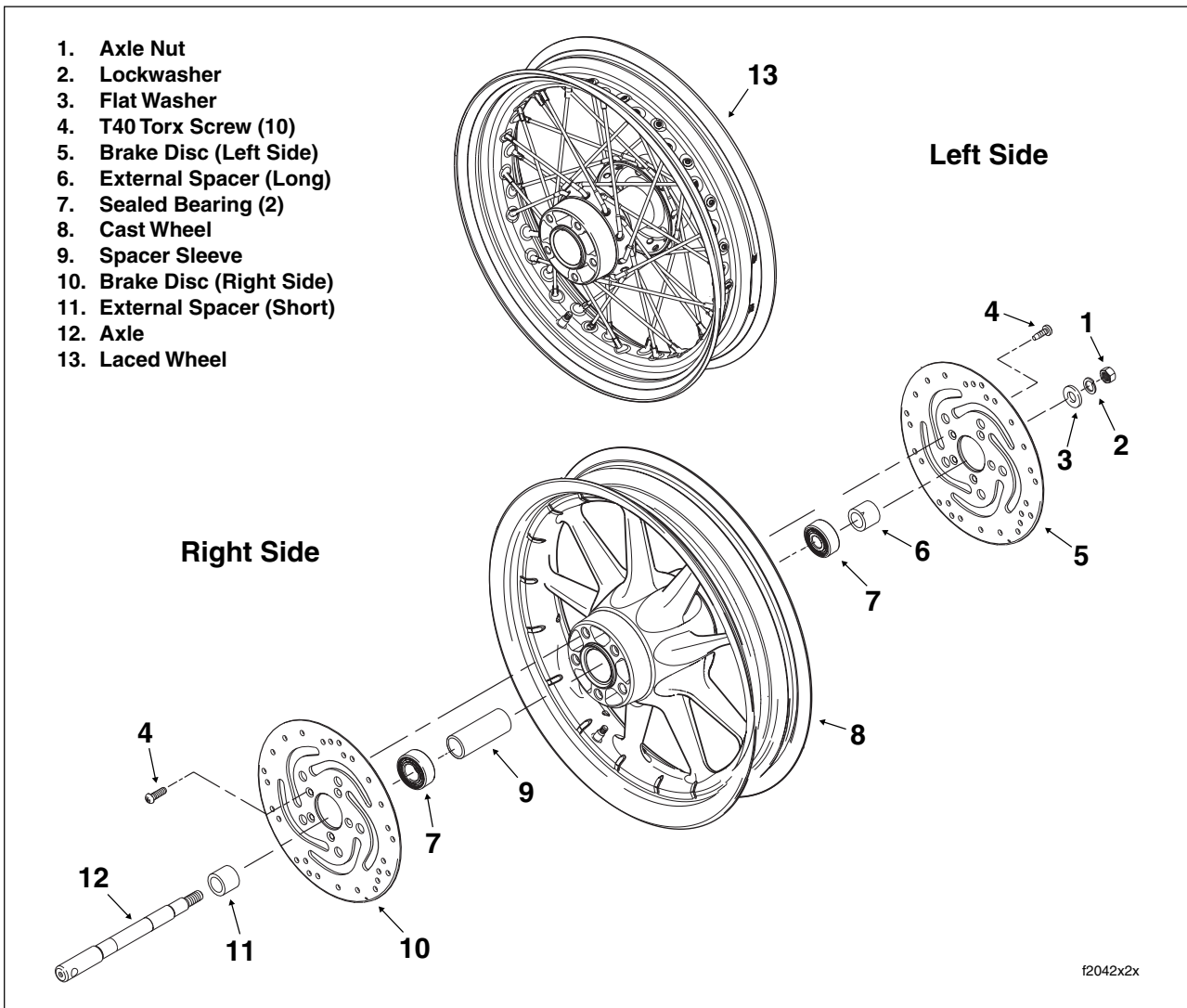

Figure 2-5. Front Wheel (Exploded View)

WARNING

Do not allow brake fluid or other lubricants to contact the brake disc. Such contact can adversely affect braking ability, which could result in death or serious injury.

2. Using a T40 TORX drive head, install brake discs on hub using **new** screws. Be sure to install discs in their original positions. Alternately tighten screws to 16-24 ft-lbs (22-33 Nm).

3. Install **new** wheel bearings as follows:

NOTE

Always install first of two bearings on the left side (opposite the valve stem side of the wheel).

- Obtain the WHEEL BEARING REMOVER/INSTALLER (HD-44060). Pick out the wheel bearing installer tools for the front wheel. See [Figure 2-6](#).
- To prolong service life and ensure smooth operation, sparingly apply graphite lubricant to threads of threaded rod.
- Slide support plate onto threaded rod. Slide rod through hub on the valve stem side of the wheel. See upper frame of [Figure 2-7](#).
- On opposite side of wheel, slide bearing onto threaded rod with lettered side facing outboard.
- Install **larger** pilot, Nice bearing, flat washer and hex nut onto rod.

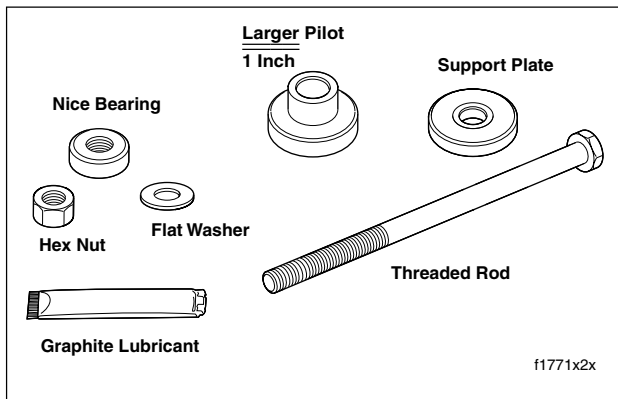

**Figure 2-6. Front Wheel Bearing Installer Tools
(Part No. HD-44060)**

- f. Holding threaded rod on opposite side of wheel to prevent rotation, turn hex nut to install bearing. See lower frame of [Figure 2-7](#). Bearing is fully seated when it makes firm contact with the counterbore.
 - g. Disassemble and remove tool, but leave support plate on threaded rod.
 - h. Slide threaded rod through installed wheel bearing and hub of wheel.
 - i. On the valve stem side of the wheel, slide spacer sleeve down threaded rod until it contacts installed wheel bearing.
 - j. Repeat steps 3(d) through 3(g) to complete installation of second wheel bearing. Bearing is fully seated when hex nut can no longer be turned.
4. Verify that wheel is true. See CHECKING CAST RIM RUNOUT or TRUING LACED WHEEL, whichever applies.
 5. Install rim strip on wheel rim, if applicable. Install tube and tire, if applicable. Verify that wheel is balanced.

INSTALLATION

1. Place wheel into position between forks with the valve stem on the right side of the vehicle.
2. Coat the axle with ANTI-SEIZE LUBRICANT.
3. Supporting wheel, insert threaded end of axle through right fork leg. Push axle through fork, **short** external spacer and wheel hub until it begins to emerge from left side.
4. With the three notches on the bearing side, push axle through **long** external spacer and left fork leg until axle shoulder contacts external spacer on right fork side.

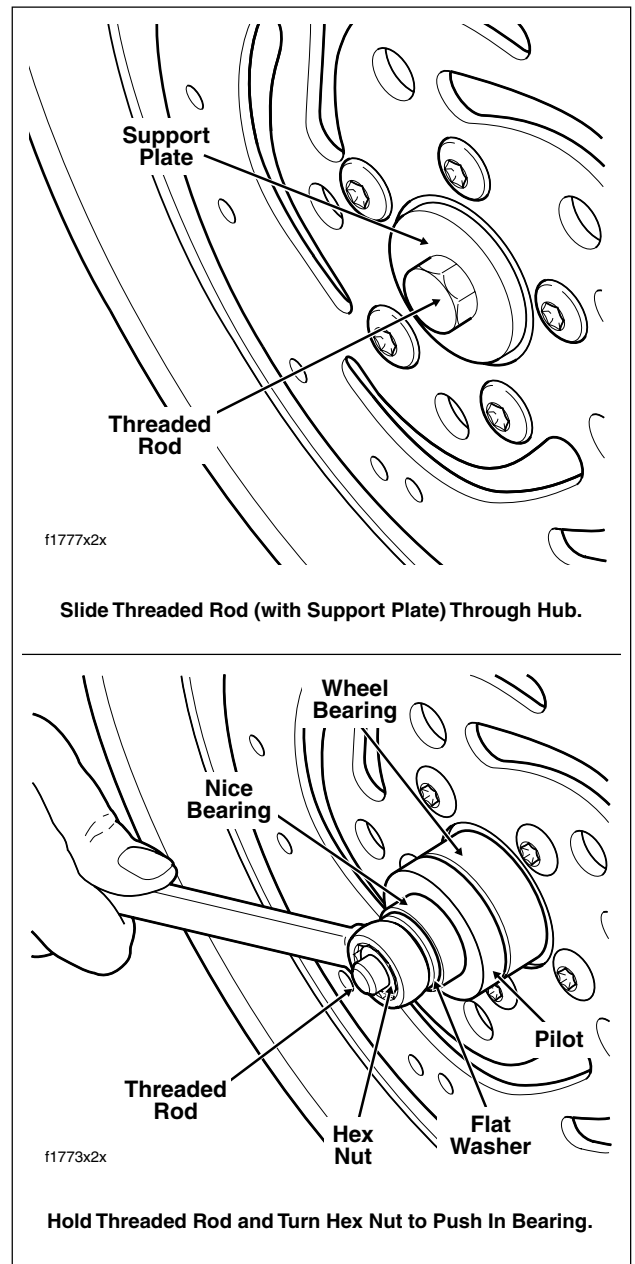

Figure 2-7. Install Sealed Wheel Bearings

5. Install flat washer, lockwasher and axle nut.
6. Insert screwdriver or steel rod through hole in axle on right side of vehicle. While holding axle stationary, tighten axle nut to 50-55 ft-lbs (68-75 Nm).
7. Insert 7/16 inch drill bit into hole in axle. See [Figure 2-8](#).
8. Pull fork leg so that it just contacts drill bit, and then tighten axle holder nuts to 132-180 **in-lbs** (14.9-20.3 Nm).

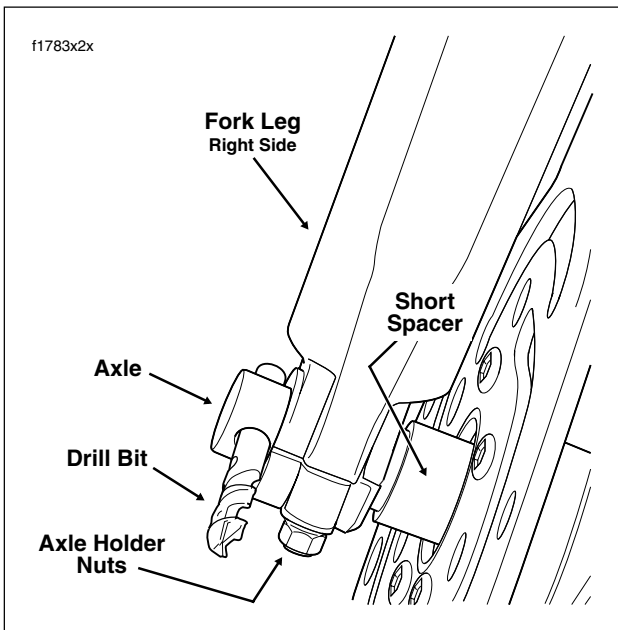

Figure 2-8. Align Front Wheel

9. Remove drill bit from axle hole.
10. Install brake caliper as follows:
 - a. Use shop rag or tape to protect fender area adjacent to caliper, as incidental contact can occur during caliper installation.
 - b. With the bleeder valve topside, position caliper so that brake disc is situated between friction pads. Pry inner and outer brake pads back for additional clearance, if necessary.
 - c. Align upper mounting hole in caliper with upper mounting lug on fork leg. Loosely install long caliper mounting bolt into upper lug of fork leg.
 - d. Install short caliper mounting bolt into lower lug of fork leg. Tighten lower mounting bolt to 28-38 ft-lbs (37.9-51.5 Nm).
 - e. Tighten upper caliper mounting bolt to 28-38 ft-lbs (37.9-51.5 Nm).
 - f. Repeat step 10 to install caliper on opposite side of wheel.

WARNING

After installation of calipers and **BEFORE** moving motorcycle, pump front brake hand lever until pistons push pads against the brake discs. If fluid pressure is not pumped up, the brake will not be available the first time it is used, a situation that could result in death or serious injury.

11. Depress front brake hand lever several times to set brake pads to proper operating position within caliper.

GENERAL

Maximum tire mileage and good handling qualities are directly related to care given wheels and tires. Wheels and tires should be regularly inspected for wear. If handling problems occur, see Section 1.21 TROUBLESHOOTING, HANDLING, for possible causes.

Always keep tires inflated to the recommended pressure and balance the wheel whenever a tire or tube is replaced.

PRELIMINARY INSPECTION

1. Measure brake disc thickness for excessive wear. Minimum acceptable thickness is stamped on side of disc. Also replace disc if warped or badly scored.
2. Whenever the wheel is removed for tire replacement or any other purpose, inspect the wheel bearings as follows:
 - a. Insert finger into wheel bearing and rotate the inner race. Repeat step on opposite side of wheel.
 - b. Replace the wheel bearings if there is rough rotation, abnormal noise or anything unusual. Always replace wheel bearings as a set. Never replace just one wheel bearing.
3. Standing on right side of vehicle, remove E-clip from groove at end of axle.
4. Remove cone nut and adjuster cam from axle.
5. Using a soft mallet, gently tap end of axle towards left side to loosen. Catching external spacers on right and left side of hub, pull axle free of wheel and rear swingarm.
6. Pull wheel to release brake disc from caliper. Pry inner and outer brake pads back for additional clearance, if necessary. Use a putty knife with a wide thin blade to avoid scoring or scratching the brake disc.
7. Remove caliper from anchor weldment on rear swingarm, and carefully hang over lower saddlebag support rail.
8. Move wheel forward and slip belt off sprocket.
9. Move wheel to bench area and inspect bearings. See [PRELIMINARY INSPECTION](#) on this page.

NOTE

Do not operate the rear brake pedal with the rear wheel removed or the caliper pistons may be forced out. Reseating pistons requires disassembly of the caliper.

REMOVAL

1. Remove saddlebags. See Section 2.25 SADDLEBAG, REMOVAL.
2. Remove both mufflers as follows:

Left Side

- a. Open worm drive clamps to remove heat shield from crossover pipe.
- b. Using a bungee cord, tie the muffler to the lower saddlebag support rail.
- c. Loosen TORCA clamp between crossover pipe and muffler.
- d. Remove two bolts (with lockwashers) to detach muffler from the lower saddlebag support rail.
- e. Remove bungee cord to release muffler from lower saddlebag support rail.

Right Side

- a. Open worm drive clamps to remove heat shield from rear header pipe.
- b. Using a bungee cord, tie the muffler to the lower saddlebag support rail.

DISASSEMBLY

1. If wheel bearing replacement is necessary, proceed as follows:
 - a. Remove five bolts (with flat washers) securing belt sprocket to hub.
 - b. Obtain the WHEEL BEARING REMOVER/INSTALLER (HD-44060). Pick out the wheel bearing remover tools for the rear wheel. See [Figure 2-9](#).

NOTE

The smaller 3/4 inch collet (and pilot) is only used to replace the rear wheel bearings on 2000-01 Touring models.

- c. To prolong service life and ensure smooth operation, sparingly apply graphite lubricant to threads of forcing screw.

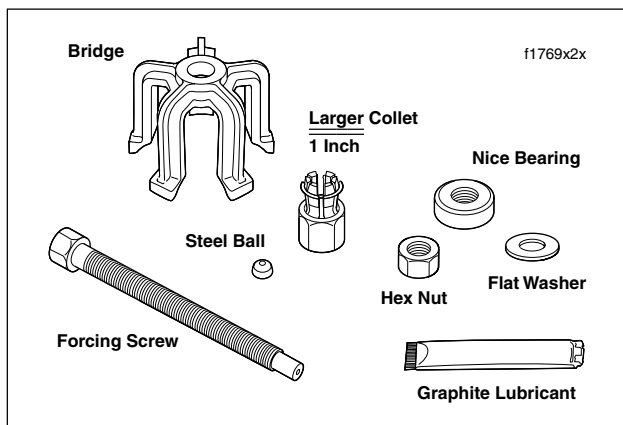

**Figure 2-9. Rear Wheel Bearing Remover Tools
(Part No. HD-44060)**

- d. Install nut, flat washer and Nice bearing on forcing screw. Insert end of forcing screw through hole in bridge.
 - e. Install steel ball inside **larger** collet. Install collet at end of forcing screw.
 - f. Insert collet into bearing ID. Feel for inside edge of bearing using lip at end of collet and then back off slightly.
 - g. Holding forcing screw to prevent rotation, turn hex on collet until lip makes firm contact with inside edge of bearing. See upper frame of [Figure 2-10](#).
 - h. Holding forcing screw, turn hex nut until bearing is free. See lower frame of [Figure 2-10](#).
 - i. Remove spacer sleeve from wheel hub.
 - j. Repeat procedure to remove bearing on opposite side of wheel. Discard bearings.
2. If brake disc replacement is necessary, use a T45 TORX drive head and remove five screws securing brake disc to hub. If the wheel is to be assembled with the same disc, mark both the wheel and disc, so that it can be installed in its original position.
 3. Remove tire, if necessary. Remove tube from the rim, if applicable. See Section [2.8 TIRES AND TUBES](#).
 4. If it is necessary to remove the hub from a laced wheel, loosen all spoke nipples and remove the rim and spokes.

CLEANING AND INSPECTION

1. Thoroughly clean all parts in solvent.
2. Inspect all parts for damage or excessive wear.

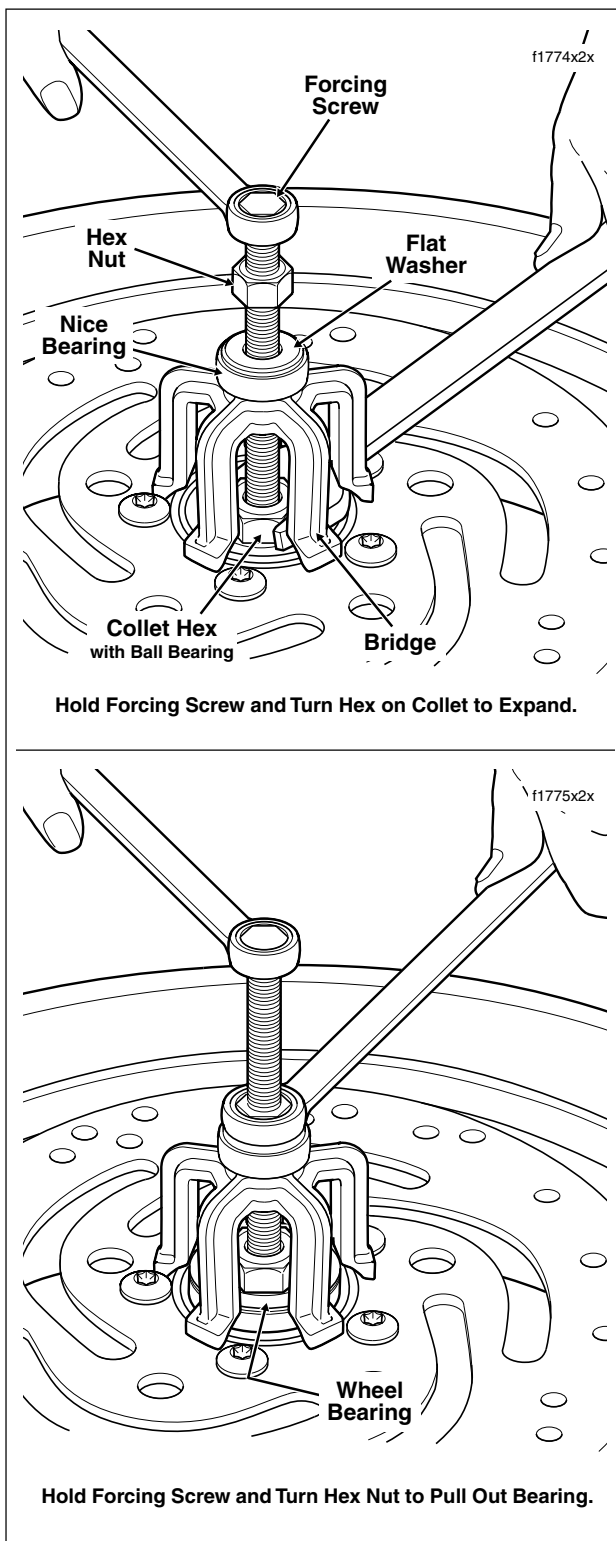

Figure 2-10. Remove Sealed Wheel Bearings

3. Always replace bearings as a complete set.



Suggest:

For more complete manuals. Please go to the home page.

<https://www.ebooklibonline.com>

If the above button click is invalid. Please download this document first, and then click the above link to download the complete manual.

Thank you so much for reading

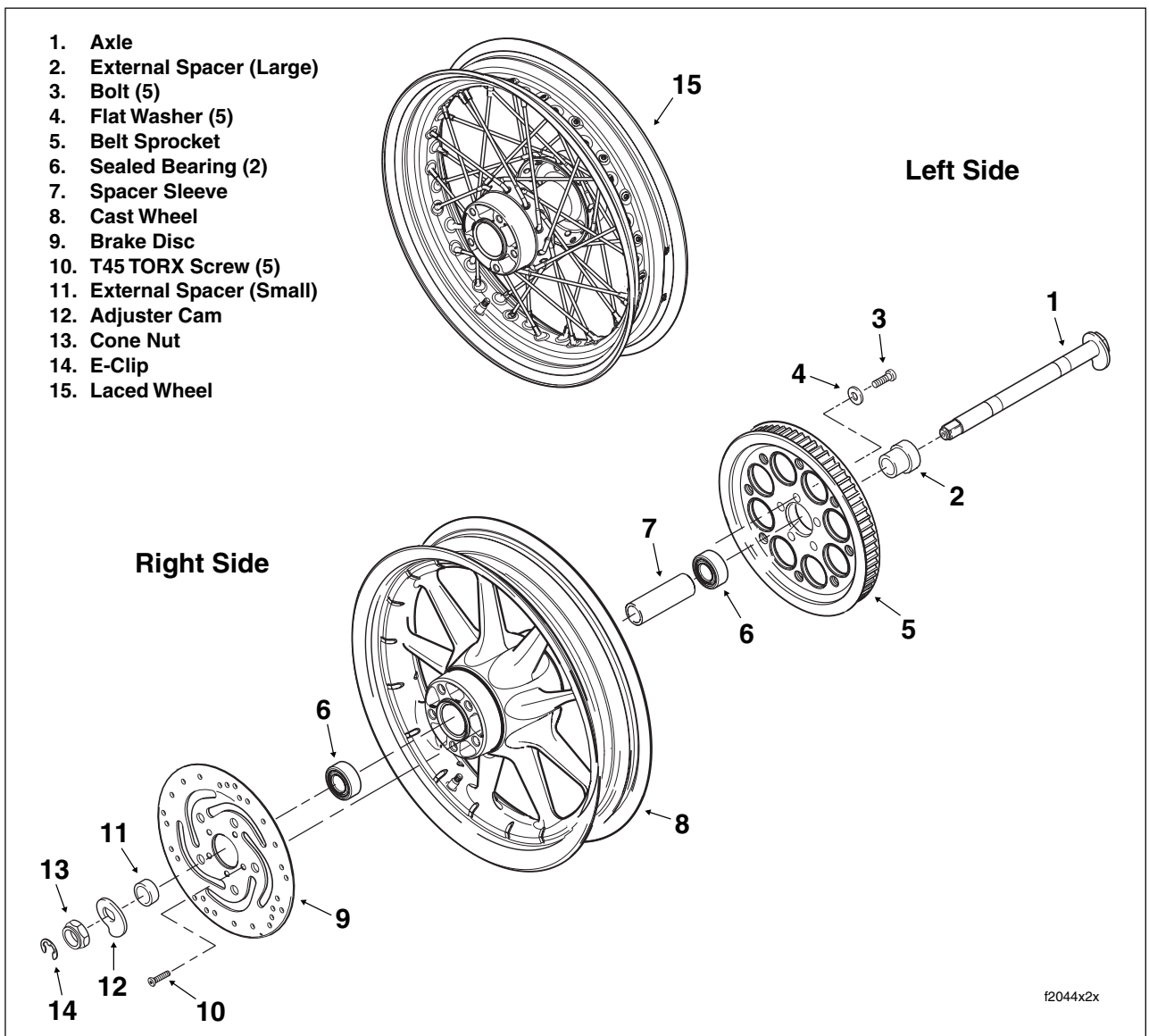

Figure 2-11. Rear Wheel (Exploded View)

- Inspect brake disc. Replace disc if warped or badly scored. Measure disc thickness for excessive wear. Minimum acceptable thickness is stamped on side of disc.
- Check the belt sprocket for wear, tooth damage, cracks or pitting. Replace if necessary.
- On laced wheels, replace spokes, rim or hub if damaged.

ASSEMBLY

- On laced wheels, if the hub and rim were disassembled, assemble the hub, spokes and rim. See Section 2.6 [WHEEL LACING-16 INCH RIM](#).

- Verify that wheel is true. See Section 2.5 [CHECKING RIM RUNOUT](#) or Section 2.7 [TRUING LACED WHEEL](#), whichever applies.

WARNING

Do not allow brake fluid or other lubricants to contact the brake disc. Such contact can adversely affect braking ability, which could result in death or serious injury.

- Using a T45 TORX drive head, install five screws (and locknuts on laced wheels) to secure brake disc to hub. Always install brake disc in its original position. Use **new** screws after three use cycles. Alternately tighten screws to 30-45 ft-lbs (41-61 Nm).

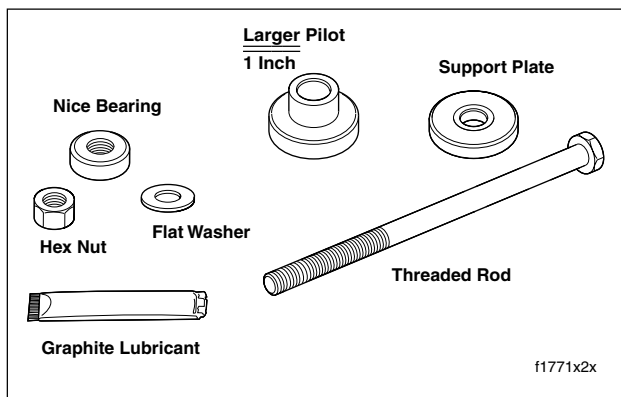

**Figure 2-12. Rear Wheel Bearing Installer Tools
(Part No. HD-44060)**

4. Install **new** wheel bearings as follows:

NOTE

Always install first of two bearings on the right side (the valve stem side of the wheel).

- Obtain the WHEEL BEARING REMOVER/INSTALLER (HD-44060). Pick out the wheel bearing installer tools for the rear wheel. See [Figure 2-12](#).
 - To prolong service life and ensure smooth operation, sparingly apply graphite lubricant to threads of threaded rod.
 - Slide support plate onto threaded rod. Slide rod through hub on the sprocket side of the wheel. See upper frame of [Figure 2-13](#).
 - On the valve stem side of the wheel, slide bearing onto threaded rod with lettered side facing out-board.
 - Install **larger** pilot, Nice bearing, flat washer and hex nut onto rod.
 - Holding threaded rod on opposite side of wheel to prevent rotation, turn hex nut to install bearing. See lower frame of [Figure 2-13](#). Bearing is fully seated when it makes firm contact with the counterbore.
 - Disassemble and remove tool, but leave support plate on threaded rod.
 - Slide threaded rod through installed wheel bearing and hub of wheel.
 - On the other side of the wheel, slide spacer sleeve down threaded rod until it contacts installed wheel bearing.
 - Repeat steps 4(d) through 4(g) to complete installation of second wheel bearing. Bearing is fully seated when hex nut can no longer be turned.
5. Install rim strip on wheel rim, if applicable. Install tube and tire, if applicable. Verify that wheel is balanced.

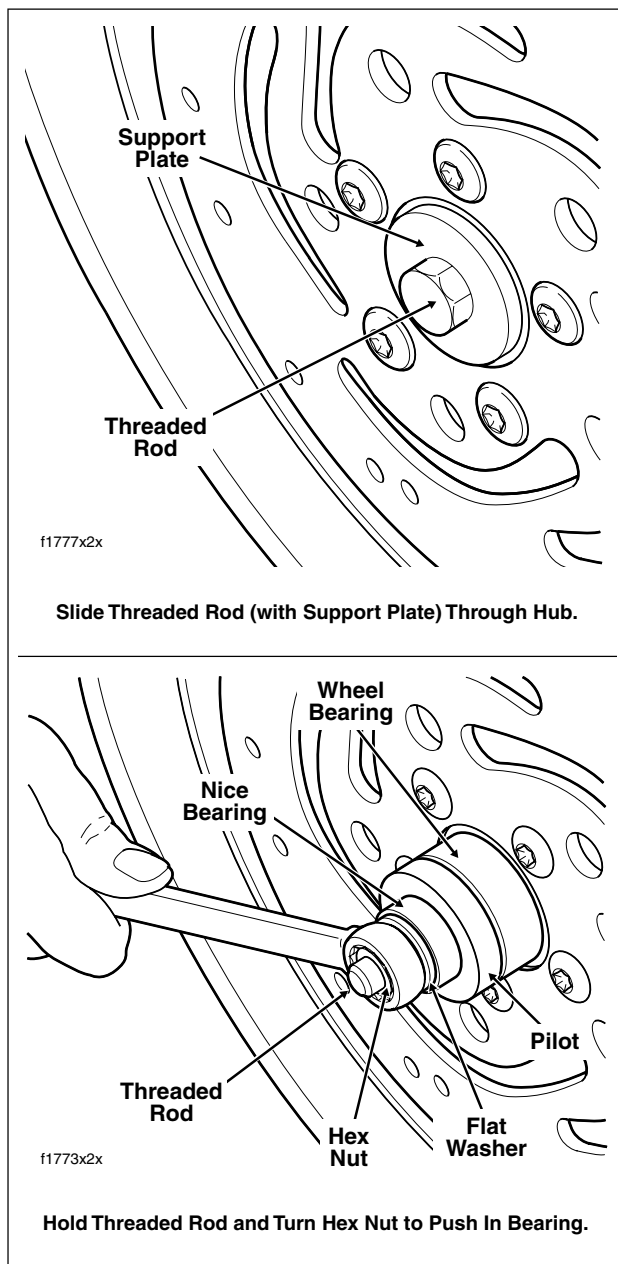

Figure 2-13. Install Sealed Wheel Bearings

- Apply two drops of Loctite High Strength Threadlocker 271 (red) to threads of five belt sprocket bolts. Always use **new** bolts after three use cycles. Install bolts with flat washers to secure sprocket to hub. Alternately tighten bolts to 55-65 ft-lbs (75-88 Nm).

INSTALLATION

- Place wheel in rear swingarm. Slide wheel far enough forward to slip belt over sprocket and then slide the wheel back.

<https://www.ebooklibonline.com>

Hello dear friend!

Thank you very much for reading.

Enter the link into your browser.

The full manual is available for immediate download.

<https://www.ebooklibonline.com>