

# 2005 XLH MODELS

---

## SERVICE MANUAL

---

### Part Number 99484-05

Section 1: Maintenance

Section 2: Chassis

Section 3: Engine

Section 4: Fuel System

Section 5: Electric Starter

Section 6: Drive/Transmission

Section 7: Electrical

Appendix

## ELECTRICAL DIAGNOSTICS

---

### Part Number 99495-05

Section 1: Starting & Charging

Section 2: Instruments

Section 3: TSM & TSSM

Section 4: Engine Management

Section 5: Wiring

<b>SUBJECT</b>	<b>PAGE NO.</b>
1.1 General .....	1-1
1.2 Fuel and Oil .....	1-5
1.3 Maintenance Schedule .....	1-6
1.4 Critical Fasteners .....	1-10
1.5 Engine Oil and Filter .....	1-11
1.6 Battery Maintenance .....	1-14
1.7 Brakes .....	1-18
1.8 Bleeding Hydraulic Brake System .....	1-19
1.9 Brake Pads and Discs .....	1-22
1.10 Tires and Wheels .....	1-27
1.11 Primary Chain .....	1-29
1.12 Clutch .....	1-30
1.13 Transmission Lubricant .....	1-32
1.14 Rear Belt Deflection .....	1-34
1.15 Rear Belt and Sprockets .....	1-38
1.16 Shock Absorber Adjustment .....	1-40
1.17 Steering Head Bearings .....	1-41
1.18 Rear Fork Bearings .....	1-42
1.19 Front Fork Oil .....	1-43
1.20 Spark Plugs .....	1-45
1.21 Cable and Chassis Lubrication .....	1-46
1.22 Air Filter Element .....	1-47
1.23 Throttle Cables and Enrichener .....	1-49
1.24 Idle Speed and Ignition Timing .....	1-51
1.25 Fuel Supply Valve Filter .....	1-52
1.26 Engine Mounts and Stabilizer Links .....	1-54
1.27 Headlamp Alignment .....	1-55
1.28 Fluid/Lubricant Requirements .....	1-57
1.29 Storage .....	1-58
1.30 Troubleshooting .....	1-60

## SERVICING A NEW MOTORCYCLE

### WARNING

**Always follow the listed service and maintenance recommendations, since they affect the safe operation of the motorcycle and the personal welfare of the rider. Failure to follow recommendations could result in death or serious injury.**

Service operations to be performed before customer delivery are specified in the applicable model year PREDELIVERY AND SETUP MANUAL.

The performance of new motorcycle initial service is required to keep warranty in force and to ensure proper emissions systems operation.

After a new motorcycle has been driven its first 1000 miles (1600 km), and at every 5000 mile (8000 km) interval thereafter, have a Harley-Davidson dealer perform the service operations listed under [1.3 MAINTENANCE SCHEDULE](#).

## SHOP PRACTICES

### Repair Notes

#### NOTES

- *General maintenance practices are given in this section.*
- *Repair = Disassembly/Assembly.*
- *Replace = Removal/Installation.*

All special tools and torque values are noted at the point of use.

All required parts or materials can be found in the appropriate PARTS CATALOG.

### Safety

Safety is always the most important consideration when performing any job. Be sure you have a complete understanding of the task to be performed. Use common sense. Use the proper tools. Protect yourself and bystanders with approved eye protection. Don't just do the job – do the job safely.

### Removing Parts

Always consider the weight of a part when lifting. Use a hoist whenever necessary. Do not lift heavy parts by hand. A hoist and adjustable lifting beam or sling are needed to remove some parts. The lengths of chains or cables from the hoist to the part should be equal and parallel and should be positioned directly over the center of the part. Be sure that no obstructions will interfere with the lifting operation. Never leave a part suspended in mid-air.

### WARNING

**Always check the capacity rating and condition of hoists, slings, chains or cables before use. Failure to do so could lead to an accident which could result in death or serious injury.**

Always use blocking or proper stands to support the part that has been hoisted. If a part cannot be removed, verify that all bolts and attaching hardware have been removed. Check to see if any parts are in the way of the part being removed.

When removing hoses, wiring or tubes, always tag each part to ensure proper installation.

### Cleaning

If you intend to reuse parts, follow good shop practice and thoroughly clean the parts before assembly. Keep all dirt out of parts; the unit will perform better and last longer. Seals, filters and covers are used in this vehicle to keep out environmental dirt and dust. These items must be kept in good condition to ensure satisfactory operation.

Clean and inspect all parts as they are removed. Be sure all holes and passages are clean and open. After cleaning, cover all parts with clean lint-free cloth, paper or other material. Be sure the part is clean when it is installed.

Always clean around lines or covers before they are removed. Plug, tape or cap holes and openings to keep out dirt, dust and debris.

Always verify cleanliness of blind holes before assembly. Tightening a screw with dirt, water or oil in the hole can cause castings to crack or break.

### Disassembly and Assembly

Always assemble or disassemble one part at a time. Do not work on two assemblies simultaneously. Be sure to make all necessary adjustments. Recheck your work when finished. Be sure that everything is done.

Operate the vehicle to perform any final check or adjustments. If all is correct, the vehicle is ready to go back to the customer.

**<https://www.ebooklibonline.com>**

Hello dear friend!

Thank you very much for reading.

Enter the link into your browser.

The full manual is available for immediate download.

**<https://www.ebooklibonline.com>**

## REPAIR AND REPLACEMENT PROCEDURES

---

### Hardware and Threaded Parts

Install helical thread inserts when inside threads in castings are stripped, damaged or not capable of withstanding specified torque.

Replace bolts, nuts, studs, washers, spacers and small common hardware if missing or in any way damaged. Clean up or repair minor thread damage with a suitable tap or die.

Replace all damaged or missing lubrication fittings.

Use Teflon pipe sealant on pipe fitting threads.

### Wiring, Hoses and Lines

Replace hoses, clamps, electrical wiring, electrical switches or fuel lines if they do not meet specifications.

### Instruments and Gauges

Replace broken or defective instruments and gauges. Replace dials and glass that are so scratched or discolored that reading is difficult.

### Bearings

Anti-friction bearings must be handled in a special way. To keep out dirt and abrasives, cover the bearings as soon as they are removed from the package.

Wash bearings in a non-flammable cleaning solution. Knock out packed lubricant inside by tapping the bearing against a wooden block. Wash bearings again. Cover bearings with clean material after setting them down to dry. Never use compressed air to dry bearings.

Coat bearings with clean oil. Wrap bearings in clean paper.

When bearings are installed against shoulders, be sure that the chamfered side of the bearing always faces the shoulder. Lubricate bearings and all metal contact surfaces before pressing into place. Only apply pressure on the part of the bearing that makes direct contact with the mating part.

Always use the proper tools and fixtures for removing and installing bearings.

Bearings do not usually need to be removed. Only remove bearings if necessary.

### Bushings

Do not remove a bushing unless damaged, excessively worn or loose in its bore. Press out bushings that must be replaced.

When pressing or driving bushings, be sure to apply pressure in line with the bushing bore. Use a bearing/bushing driver or a bar with a smooth, flat end. Never use a hammer to drive bushings.

Inspect the bushing and the mated part for oil holes. Be sure all oil holes are properly aligned.

### Gaskets

Always discard gaskets after removal. Replace with **new** gaskets. Never use the same gasket twice. Be sure that gasket holes match up with holes in the mating part.

### Lip Type Seals

Lip seals are used to seal oil or grease and are usually installed with the sealing lip facing the contained lubricant. Seal orientation, however, may vary under different applications.

Seals should not be removed unless necessary. Only remove seals if required to gain access to other parts or if seal damage or wear dictates replacement.

Leaking oil or grease usually means that a seal is damaged. Replace leaking seals to prevent overheated bearings.

Always discard seals after removal. Do not use the same seal twice.

### O-Rings (Preformed Packings)

Always discard O-rings after removal. Replace with **new** O-rings. To prevent leaks, lubricate the O-rings before installation. Apply the same type of lubricant as that being sealed. Be sure that all gasket, O-ring and seal mating surfaces are thoroughly clean before installation.

## Gears

Always check gears for damaged or worn teeth.

Lubricate mating surfaces before pressing gears on shafts.

## Shafts

If a shaft does not come out easily, check that all nuts, bolts or retaining rings have been removed. Check to see if other parts are in the way before using force.

Shafts fitted to tapered splines should be very tight. If shafts are not tight, disassemble and inspect tapered splines. Discard parts that are worn. Be sure tapered splines are clean, dry and free of burrs before putting them in place. Press mating parts together tightly.

Clean all rust from the machined surfaces of new parts.

## Part Replacement

Always replace worn or damaged parts with **new** parts.

## CLEANING

---

### Part Protection

Before cleaning, protect rubber parts (such as hoses, boots and electrical insulation) from cleaning solutions. Use a grease-proof barrier material. Remove the rubber part if it cannot be properly protected.

### Cleaning Process

Any cleaning method may be used as long as it does not result in parts damage. Thorough cleaning is necessary for proper parts inspection. Strip rusted paint areas to bare metal before repainting.

### Rust or Corrosion Removal

Remove rust and corrosion with a wire brush, abrasive cloth, sand blasting, vapor blasting or rust remover. Use buffing crocus cloth on highly polished parts that are rusted.

### Bearings

Clean open bearings by soaking them in a petroleum cleaning solution. Never use a solution that contains chlorine.

Let bearings stand and dry. Do not dry with compressed air. Do not spin bearings while they are drying.

## TOOL SAFETY

---

### Air Tools

- Always use approved eye protection equipment when performing any task using air-operated tools.
- On all power tools, use only recommended accessories with proper capacity ratings.
- Do not exceed air pressure ratings of any power tools.
- Bits should be placed against work surface before air hammers are operated.
- Disconnect the air supply line to an air hammer before attaching a bit.
- Never point an air tool at yourself or another person.
- Protect bystanders with approved eye protection.

### Wrenches

- Never use an extension on a wrench handle.
- If possible, always pull on a wrench handle and adjust your stance to prevent a fall if something lets go.
- Never cock a wrench.
- Never use a hammer on any wrench other than a STRIKING FACE wrench.
- Discard any wrench with broken or battered points.
- Never use a pipe wrench to bend, raise or lift a pipe.

### Pliers/Cutters/Prybars

- Plastic- or vinyl-covered pliers handles are not intended to act as insulation; don't use on live electrical circuits.
- Don't use pliers or cutters for cutting hardened wire unless they were designed for that purpose.
- Always cut at right angles.
- Don't use any prybar as a chisel, punch or hammer.

## Hammers

- Never strike a hammer against a hardened object, such as another hammer.
- Always grasp a hammer handle firmly, close to the end.
- Strike the object with the full face of the hammer.
- Never work with a hammer which has a loose head.
- Discard hammer if face is chipped or mushroomed.
- Wear approved eye protection when using striking tools.
- Protect bystanders with approved eye protection.

## Punches/Chisels

- Never use a punch or chisel with a chipped or mushroomed end; dress mushroomed chisels and punches with a file.
- Hold a chisel or a punch with a tool holder if possible.
- When using a chisel on a small piece, clamp the piece firmly in a vise and chip toward the stationary jaw.
- Wear approved eye protection when using these tools.
- Protect bystanders with approved eye protection.

## Screwdrivers

- Don't use a screwdriver for prying, punching, chiseling, scoring or scraping.
- Use the right type of screwdriver for the job; match the tip to the fastener.
- Don't interchange POZIDRIV®, PHILLIPS® or REED AND PRINCE screwdrivers.
- Screwdriver handles are not intended to act as insulation; don't use on live electrical circuits.
- Don't use a screwdriver with rounded edges because it will slip – redress with a file.

## Ratchets and Handles

- Periodically clean and lubricate ratchet mechanisms with a light grade oil. Do not replace parts individually; ratchets should be rebuilt with the entire contents of service kit.
- Never hammer or put a pipe extension on a ratchet or handle for added leverage.
- Always support the ratchet head when using socket extensions, but do not put your hand on the head or you may interfere with the action of its reversing mechanism.
- When breaking loose a fastener, apply a small amount of pressure as a test to be sure the ratchet's gear wheel is engaged with the pawl.

## Sockets

- Never use hand sockets on power or impact wrenches.
- Select the right size socket for the job.
- Never cock any wrench or socket.
- Select only impact sockets for use with air or electric impact wrenches.
- Replace sockets showing cracks or wear.
- Keep sockets clean.
- Always use approved eye protection when using power or impact sockets.

## Storage Units

- Don't open more than one loaded drawer at a time. Close each drawer before opening up another.
- Close lids and lock drawers and doors before moving storage units.
- Don't pull on a tool cabinet; push it in front of you.
- Set the brakes on the locking casters after the cabinet has been rolled to your work.

## FUEL

### ⚠ WARNING

**Avoid spills. Slowly remove filler cap. Do not fill above bottom of filler neck insert, leaving air space for fuel expansion. Secure filler cap after refueling. Gasoline is extremely flammable and highly explosive, which could result in death or serious injury. (00028a)**

Harley-Davidson motorcycles were designed to obtain the best performance and efficiency using unleaded gasoline (91 pump octane or higher for the XL 1200 Custom and XL 1200 Roadster, 87 or higher for all other models). Pump octane is the octane number usually shown on the gas pump. Some fuel suppliers sell gasoline/alcohol blends as a fuel. The type and amount of alcohol added to the fuel is important.

## GASOLINE BLENDS

### CAUTION

**Do not use gasoline that contains methanol. Doing so can result in fuel system component failure, engine damage and/or equipment malfunction. (00148a)**

Harley-Davidson motorcycles are designed to give the best performance using unleaded gasoline. Some fuel suppliers sell gasoline/alcohol blends as a fuel. The type and amount of alcohol added to the fuel is important.

- **DO NOT USE GASOLINES CONTAINING METHANOL.** Using gasoline/methanol blends will result in starting and driveability deterioration and damage to critical fuel system components.
- **ETHANOL** is a mixture of 10% ethanol (Grain alcohol) and 90% unleaded gasoline. It is identified as “gasohol,” “ethanol enhanced,” or “contains ethanol.” Gasoline/ethanol blends can be used in your motorcycle if the ethanol content does not exceed 10%.
- **REFORMULATED OR OXYGENATED GASOLINES (RFG):** “Reformulated gasoline” is a term used to describe gasoline blends that are specifically designed to burn cleaner than other types of gasoline. Your motorcycle will run normally using this type of gas.

Because of their generally higher volatility, these blends may adversely affect the starting, driveability and fuel efficiency of your motorcycle. If you experience these problems, Harley-Davidson recommends you operate your motorcycle on straight, unleaded gasoline.

## ENGINE OIL

Use the proper grade of oil for the lowest temperature expected before the next oil change.

If it is necessary to add oil and Harley-Davidson oil is not available, use an oil certified for diesel engines. Acceptable diesel engine oil designations include CF, CF-4, CG-4 and CH-4. The preferred viscosities for the diesel engine oils, in descending order, are 20W-50, 15W-40 and 10W-40. At the first opportunity, see a Harley-Davidson dealer to change back to 100 percent Harley-Davidson oil.

See [1.5 ENGINE OIL AND FILTER](#) for all service information.

## WINTER LUBRICATION

Normal fuel combustion in a gasoline engine produces water vapor and carbon dioxide along with other gases and particulates. During starting and warm-up in cold weather, especially in freezing temperatures, the vapor condenses to water before the crankcase is hot enough to exhaust it through the breather system. If the engine is driven long enough to thoroughly warm the crankcase, most of this liquid water is again vaporized and exhausted through the crankcase breather system.

A moderately driven vehicle making short runs may not be able to vacate water vapors allowing liquid water to accumulate in the oil tank. This is especially true if the vehicle is operated in cold weather. In freezing weather, an accumulation of water in the engine oil may become slush or ice, which can block oil lines and lead to severe engine damage. Water remaining in the engine oil for long periods of time can form an acidic sludge that is corrosive to metal engine parts and causes accelerated wear of moving components.

Always change the engine oil more often in winter. The colder the weather, the shorter the recommended oil change interval. If the engine is used for short runs, change the oil even more frequently.

Table 1-1. Regular Service Intervals For Sportster Models

ITEM SERVICED	PROCEDURE	1000	5000	10,000	15,000	20,000	25,000	NOTES
		MI	MI	MI	MI	MI	MI	
		1600	8000	16,000	24,000	32,000	40,000	
		KM	KM	KM	KM	KM	KM	
Engine oil and filter	Replace	X	X	X	X	X	X	
Oil lines and brake system	Inspect for leaks	X	X	X	X	X	X	1
Air cleaner	Inspect, service as required	X	X	X	X	X	X	
Tires	Check pressure, inspect tread	X	X	X	X	X	X	
Wheel spokes	Check tightness	X	X	X	X	X	X	1, 4
Transmission lubricant	Replace	X	X	X	X	X	X	
Clutch	Check adjustment	X	X	X	X	X	X	1
Primary chain	Check adjustment	X	X	X	X	X	X	
Rear belt and sprockets	Inspect, adjust belt	X	X	X	X	X	X	1
Throttle, brake, enricher and clutch controls	Check, adjust and lubricate	X	X	X	X	X	X	1
Jiffy stand	Inspect and lubricate	X		X		X		1
Fuel valve, lines and fittings	Inspect for leaks	X	X	X	X	X	X	1
Fuel tank filter screen	Clean						X	1
Brake fluid	Check levels and condition	X	X	X	X	X	X	
Brake pads and discs	Inspect for wear	X	X	X	X	X	X	
Front brake lever pin	Inspect		X	X	X	X		1, 2
	Lubricate						X	1, 2
Brake caliper pins	Inspect		X	X	X	X		1, 2
	Lubricate						X	1, 2
Brake caliper boots and bushings	Inspect		X	X	X	X		1, 2
	Replace						X	1, 2
Rear master cylinder outer boot	Inspect		X	X	X	X	X	1, 2
Brake components	Replace brake rubber components in master cylinders and calipers						X	1, 2
	Lubricate master cylinder pistons						X	1, 2
Spark plugs	Inspect	X	X		X		X	
	Replace			X		X		
Electrical equipment and switches	Check operation	X	X	X	X	X	X	
Engine idle speed	Check adjustment	X	X	X	X	X	X	1
Front fork oil	Replace					X		1
Steering head bearings	Adjust	X				X		1
	Lubricate					X		1
Rear fork bearings								Replace every 30,000 mi (48,000 km) 1
Shock absorbers	Inspect	X	X	X	X	X	X	1
Critical fasteners	Check tightness	X		X		X		1

**Table 1-1. Regular Service Intervals For Sportster Models**

ITEM SERVICED	PROCEDURE	1000	5000	10,000	15,000	20,000	25,000	NOTES
		MI	MI	MI	MI	MI	MI	
		1600	8000	16,000	24,000	32,000	40,000	
		KM	KM	KM	KM	KM	KM	
Engine mounts and stabilizer links	Inspect			X		X		1
Battery	Check battery and clean connections							3
Road test	Verify component and system functions	X	X	X	X	X	X	
NOTES	<ol style="list-style-type: none"> <li>1. Should be performed by an authorized Harley-Davidson dealer, unless you have the proper tools, service data and are mechanically qualified.</li> <li>2. Replace every four (4) years.</li> <li>3. Perform annually.</li> <li>4. Not all vehicles are equipped with spoke wheels. Consult appropriate topic in service manual.</li> </ol>							

**Table 1-2. Quick Reference Maintenance Chart**

ITEM SERVICED	SPECIFICATION	DATA
Engine oil and filter	Oil capacity	3.6 qt. (3.4 L)
	Filter	Hand tighten 1/2-3/4 turn after gasket contact
	Chrome filter (XL 1200C)	Part no. 63796-77A
	Black filter (all except XL 1200C)	Part no. 63805-80A
Primary chain tension	Deflection with hot engine	1/4-3/8 in. (6.3-9.5 mm)
	Deflection with cold engine	3/8-1/2 in. (9.5-12.7 mm)
	Chain tensioner nut torque	20-25 ft-lbs (27.1-33.9 Nm)
	Primary chain inspection cover torque	40-60 <b>in-lbs</b> (4.5-6.8 Nm)
Primary chain/ transmission lubricant	Lubricant capacity	32 oz. (946 mL)
	Primary chaincase drain plug torque	14-30 ft-lbs (19.0-40.7 Nm)
Clutch adjustment	Free play at adjuster screw	1/4 turn
	Free play at hand lever	1/16-1/8 (1.6-3.2 mm)
	Clutch inspection cover torque	84-108 <b>in-lbs</b> (9.5-12.2 Nm)
Tire condition and pressure	Pressure for solo rider	Front: 30 psi (207 kPa) Rear: 36 psi (248 kPa)
	Pressure for rider and passenger	Front: 30 psi (207 kPa) Rear: 40 psi (276 kPa)
	Wear	Replace tire if 1/32 in. (0.8 mm) or less of tread pattern remains
Wheel spokes	Spoke nipple torque	40-50 <b>in-lbs</b> (4.5-5.7 Nm)
Steering head bearings	Lubricant for neck fitting	SPECIAL PURPOSE GREASE Part no. 99857-97 (14 oz. cartridge)
Brake fluid reservoir level	D.O.T. 5 silicone hydraulic brake fluid	Part no. 99902-77 (12 oz.) Part no. 99901-77 (gal)
	Proper fluid level (front brake)	1/4 in. (6 mm) from the top of the reservoir
	Proper fluid level (rear brake)	Upper fluid level in reservoir
	Front master cylinder reservoir cover screws	9-17 <b>in-lbs</b> (1.0-2.0 Nm)
Brake pad linings and discs	Minimum brake pad thickness	0.04 in. (1.02 mm)
	Minimum brake disc thickness	See stamp on side of disc
Drive belt	Upward measurement force applied at midpoint of bottom belt strand	10 lb. (4.5 kg)
	Belt deflection with motorcycle on jiffy stand, belt and sprockets at ambient temperature (cold engine), without rider or luggage	XL 883L/XL 883C/XL 1200C: 1/4-5/16 in. (6.4-7.9 mm) XL 883/XL 1200R: 3/8-7/16 in. (9.5-11.1 mm)
Air cleaner	Air filter element screw torque	40-60 <b>in-lbs</b> (4.5-6.8 Nm)
	Air cleaner cover screw torque	30-60 <b>in-lbs</b> (4.1-6.8 Nm)

**Table 1-2. Quick Reference Maintenance Chart**

ITEM SERVICED	SPECIFICATION	DATA
Fuel tank filter	Sealant for fuel valve and fuel tank adapter	LOCTITE PIPE SEALANT WITH TEFLON 565 Part no. 99818-97 (6 ml)
	Hex jam nut torque	15-20 ft-lbs (20.3-27.1 Nm)
Enrichener control	Hex nut torque	20-35 <b>in-lbs</b> (2.3-4.0 Nm)
Clutch and throttle cables	Lubricant	SUPER OIL Part no. 94968-85TV (1/4 fl. oz.)
	Handlebar clamp screw torque	108-132 <b>in-lbs</b> (12.2-14.9 Nm)
	Handlebar switch housing screw torque	35-45 <b>in-lbs</b> (3.9-5.0 Nm)
Spark plugs	Type	HD-6R12
	Gap	0.038-0.043 in. (0.96-1.09 mm)
	Torque	12-18 ft-lbs (16.3-24.4 Nm)
Engine idle speed	Idle speed	950-1050 RPM
Front fork oil	Type	HYDRAULIC FORK OIL (TYPE E) Part no. 99884-80 (16 oz.)
Battery	Lubricant	ELECTRICAL CONTACT LUBRICANT Part no. 99861-02 (1 oz.)
	Terminal screw torque	40-50 <b>in-lbs</b> (4.5-5.7 Nm)

**INSPECTION**

Inspect critical fasteners, except head bolts.

Refer to [Table 1-3](#). Tighten all critical fasteners, except head bolts, to service manual specifications. Replace any damaged or missing hardware.

**Table 1-3. Critical Fasteners**

SYSTEM	FASTENER	TORQUE	
Hand controls	Upper and lower switch housing screws	35-45 <b>in-lbs</b>	3.9-5.0 Nm
	Clutch lever handlebar clamp screws	108-132 <b>in-lbs</b>	12.2-14.9 Nm
	Master cylinder handlebar clamp screws	108-132 <b>in-lbs</b>	12.2-14.9 Nm
Engine	Stabilizer link screws	25-35 ft-lbs	33.9-47.5 Nm
	Upper front stabilizer link-to-frame mounting bracket screws	25-35 ft-lbs	33.9-47.5 Nm
	Upper front stabilizer link-to-engine mounting bracket screws	55-65 ft-lbs	74.6-88.2 Nm
	Lower front stabilizer link-to-frame mounting bracket screws	25-35 ft-lbs	33.9-47.5 Nm
	Front isolator mounting bolt	60-70 ft-lbs	81.4-95.0 Nm
	Rear isolator/rear fork pivot shaft bolts	60-70 ft-lbs	81.4-95.0 Nm
	Front isolator mounting bracket screws (left side)	25-35 ft-lbs	33.9-47.5 Nm
	Rear isolator mounting bracket screws (left side)	25-35 ft-lbs	33.9-47.5 Nm
Brakes	Brake line banjo bolts	20-25 ft-lbs	27.1-33.9 Nm
	Brake disc mounting screws, front	16-24 ft-lbs	21.7-32.5 Nm
	Brake disc mounting screws, rear	30-45 ft-lbs	40.7-61.0 Nm
	Front master cylinder reservoir cover screws	9-17 <b>in-lbs</b>	1.0-2.0 Nm
	Rear master cylinder mounting screws	15-20 ft-lbs	20.3-27.1 Nm
	Rear master cylinder bracket-to-frame mounting screws	17-22 ft-lbs	23.1-29.9 Nm
	Front brake caliper mounting screws	28-38 ft-lbs	38.0-51.6 Nm
Axle nuts	Front axle	50-55 ft-lbs	67.8-74.6 Nm
	Rear axle	72-78 ft-lbs	98-106 Nm
Front fork/ handlebars	Lower bracket pinch screws	30-35 ft-lbs	40.7-47.5 Nm
	Upper bracket pinch screws	30-35 ft-lbs	40.7-47.5 Nm
	Steering stem bolt	15 ft-lbs, loosen, 7 ft-lbs	20.4 Nm, loosen, 9.5 Nm
	Steering stem pinch screw	30-35 ft-lbs	40.7-47.5 Nm
	Front axle pinch screw	21-27 ft-lbs	28.5-36.6 Nm
	Handlebar clamp mounting screw	12-18 ft-lbs	16.3-24.4 Nm
	Riser mounting bolts	30-40 ft-lbs	40.7-54.3 Nm
Final drive	Rear sprocket mounting bolts	55-65 ft-lbs	74.6-88.2 Nm

## CHECKING AND ADDING OIL

Check engine oil level in oil tank and add oil if necessary. Oil tank capacity is 3.6 quarts (U.S.) (3.4 liters). Refer to [Table 1-4](#) on the next page for recommended engine oil viscosity.

### Removing and Replacing Oil Filler Cap

- See [Figure 1-1](#). Remove filler cap from oil tank on right side of vehicle.
  - Press straight down on filler cap and release. Cap will pop up.
  - Pull up on filler cap while turning counterclockwise one-quarter turn as if unscrewing filler cap.
- Wipe attached dipstick clean.

#### NOTE

See [Figure 1-2](#). Note that dipstick has a wide slot (1) and a narrow slot (2) and can only be inserted in oil tank one way.

- Insert dipstick into tank. Turn filler cap clockwise one-quarter turn as if screwing filler cap into tank. When filler cap stops turning, it is fully seated. Press down on filler cap until it snaps in place, flush with top of oil tank cover.

### Checking Oil With Cold Engine

- Position motorcycle so that it is leaning on jiffy stand.
- Remove filler cap. See [Removing and Replacing Oil Filler Cap](#) above. Wipe attached dipstick clean. Reinstall oil filler cap in tank.
- Remove oil filler cap again and check oil level on dipstick. See [Figure 1-3](#). Dipstick has two marks. If oil level is at or below lower mark (2), add only enough oil to bring the level to a point between the two arrows on the dipstick. Replace filler cap.

### Checking Oil With Warm Engine

- Run engine until engine oil is at normal operating temperature. Turn engine off.
- Position motorcycle so that it is leaning on jiffy stand.
- Remove filler cap. See [Removing and Replacing Oil Filler Cap](#) above. Wipe attached dipstick clean. Reinstall oil filler cap in tank.
- Remove filler cap again and check warm oil level on dipstick. See [Figure 1-3](#). Dipstick has two marks. If oil level in tank is at or below lower mark, add one quart (0.946 liter) of Harley-Davidson oil to tank. Replace filler cap.
- If you added oil in step 4, remove filler cap and verify correct engine oil level in oil tank. Do not fill oil tank to the level above upper mark on dipstick. Replace filler cap.

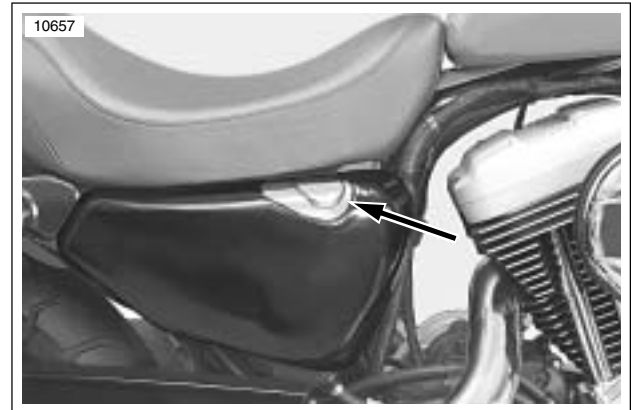

Figure 1-1. Filler Cap/Dipstick Location

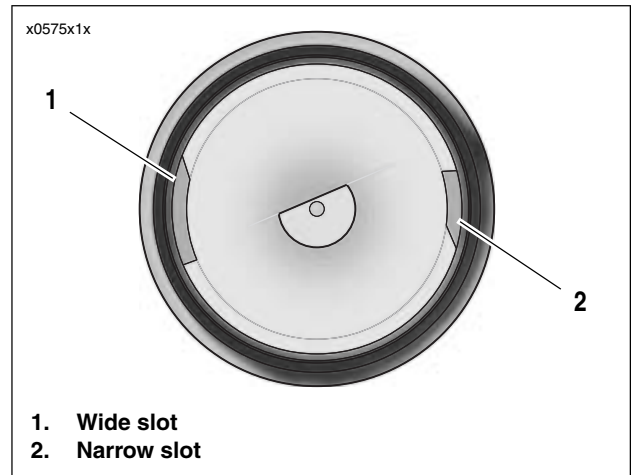

Figure 1-2. Filler Cap/Dipstick

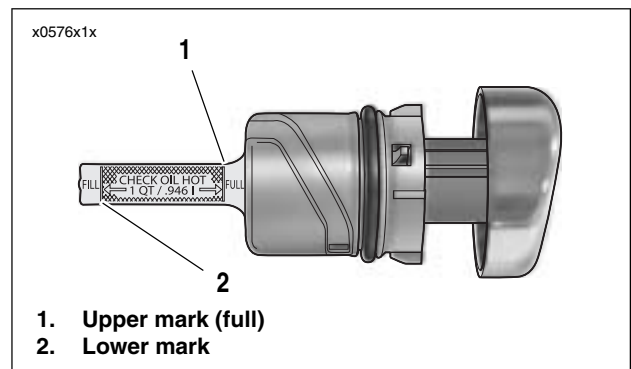

Figure 1-3. Checking Oil Level

**Table 1-4. Recommended Engine Oil Viscosity**

HARLEY-DAVIDSON TYPE	VISCOSITY	HARLEY-DAVIDSON RATING	LOWEST AMBIENT TEMPERATURE	COLD WEATHER STARTS BELOW 50° F (10° C)
HD Multigrade	SAE 10W40	HD 360	Below 40° F (4° C)	Excellent
HD Multigrade	SAE 20W50	HD 360	Above 40° F (4° C)	Good
HD Regular Heavy	SAE 50	HD 360	Above 60° F (16° C)	Poor
HD Extra Heavy	SAE 60	HD 360	Above 80° F (27° C)	Poor

## CHANGING OIL AND FILTER

### General

PART NO.	SPECIALTY TOOL
HD-42311 or HD-44067	Oil filter wrench

Completely drain oil tank of used oil at scheduled service intervals as specified in [1.3 MAINTENANCE SCHEDULE](#). Refer to [Table 1-1](#). Refill with fresh oil.

#### NOTES

- If vehicle is driven extremely hard, used in competition, or driven on dusty roads, change engine oil at shorter intervals.
- Always change oil filter when changing engine oil.

### Draining Oil Tank

1. Run engine until engine oil has reached normal operating temperature.
2. Place a suitable container under the engine crankcase. The container must be able to hold approximately four quarts (U.S.) (3.8 liters).

#### NOTE

Oil will drain more quickly if filler cap/dipstick is removed from oil tank as described on previous page.

3. See [Figure 1-4](#). Locate the oil tank drain hose (1). The drain hose is secured with a worm drive clamp (2) to a plug on a frame clip (3).
4. Remove frame clip. Pull clip straight away from frame tube.

5. Loosen worm drive clamp, pull drain hose from frame clip plug and insert free end of hose into container. Completely drain engine oil from oil tank. It is not necessary to drain engine crankcase.
6. Replace drain hose on frame clip plug and tighten worm drive clamp securely.
7. Reinstall frame clip on frame rail. Make sure clip and drain hose are tucked up under crankcase and not hanging down from frame tube.

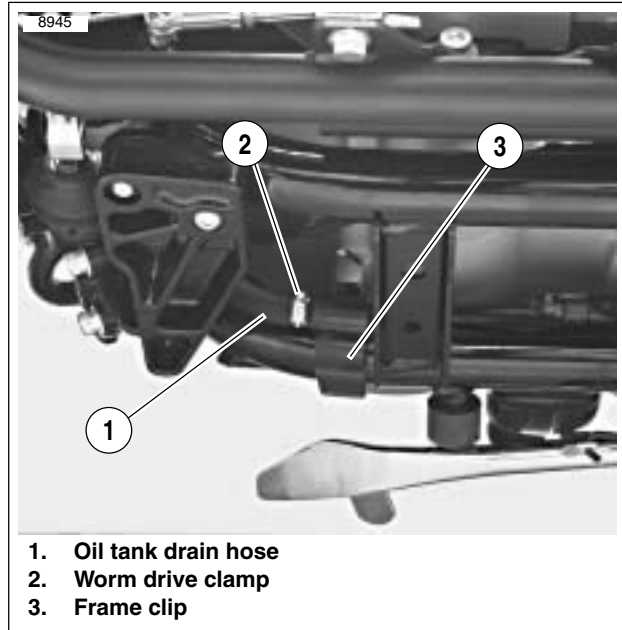

**Figure 1-4. Oil Tank Drain Hose**

## Removing Oil Filter

1. Place a drain pan beneath front of engine crankcase.
2. See [Figure 1-5](#). See [Figure 1-6](#). Remove oil filter using OIL FILTER WRENCH (Part No. HD-42311 or HD-44067-A). Turn oil filter counterclockwise to remove from filter mount.
3. Drain oil filter into drain pan. Discard oil filter.

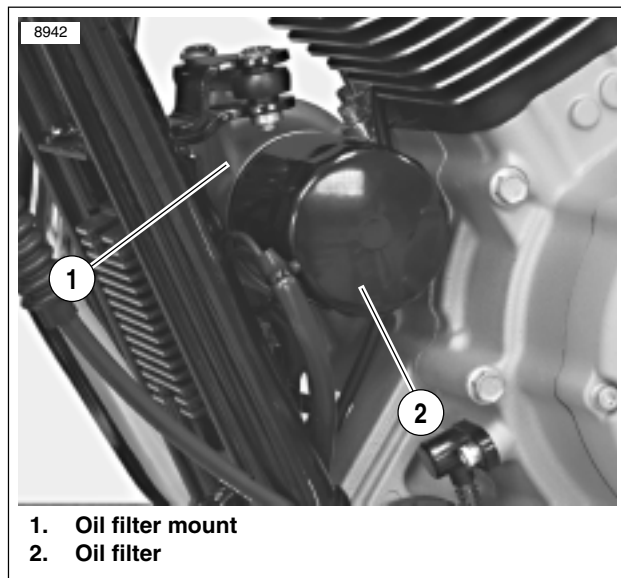

Figure 1-5. Oil Filter

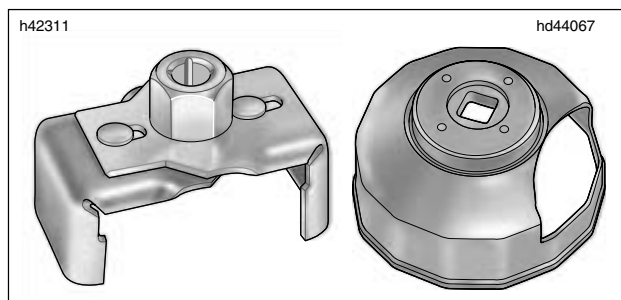

Figure 1-6. Oil Filter Wrench  
Part No. HD-42311 (left), HD-44067-A (right)

## Installing New Oil Filter

### NOTE

Partially fill oil filter before installation to minimize the time required for buildup of oil pressure when engine is first started.

1. Pour about 4 fluid ounces (U.S.) (120 ml) of fresh, clean engine oil into **new** oil filter. Allow time for oil to soak into filter element.
2. Wipe filter gasket contact surface of oil filter mount with a clean cloth.
3. See [Figure 1-7](#). Coat oil filter gasket with clean Harley-Davidson 20W-50 engine oil.

### IMPORTANT NOTE

**Do NOT use oil filter wrench to install new oil filter.**

4. Install **new** oil filter. Turn filter clockwise to install. Hand tighten filter 1/2 to 3/4-turn after gasket contacts filter mount surface.

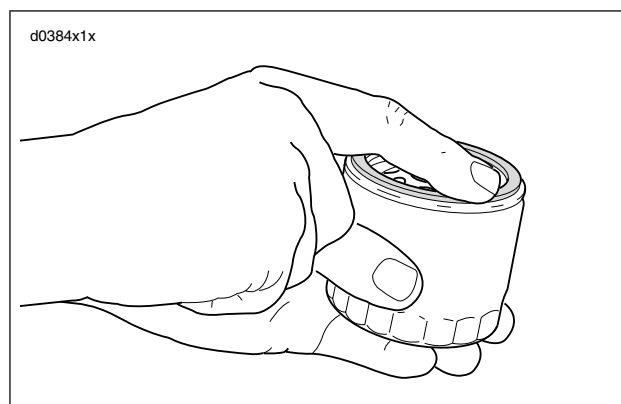

Figure 1-7. Lubricating New Oil Filter Gasket

## Refilling Oil Tank

1. Refer to [Table 1-4](#). Always use the proper grade of oil for the lowest expected air temperature before the next regularly scheduled oil change. Pour 3.6 quarts (U.S.) (3.4 liters) of oil into engine oil tank minus the 4 fl. oz. (120 ml) added in step 1.
2. Install filler cap onto oil tank as described on previous page. Make sure cap is fully seated.
3. Start engine. Verify that oil pressure signal light turns off when engine speed is 1000 RPM or above. Turn engine off.
4. Check for oil leaks at oil filter and oil tank drain hose. Check engine oil level. See [CHECKING AND ADDING OIL](#).

## GENERAL

**WARNING**

Batteries contain sulfuric acid, which could cause severe burns to eyes and skin. Wear a protective face shield, rubberized gloves and protective clothing when working with batteries. **KEEP BATTERIES AWAY FROM CHILDREN.** (00063a)

**WARNING**

Never remove warning label attached to top of battery. Failure to read and understand all precautions contained in warning, could result in death or serious injury. (00064a)

All AGM batteries are permanently sealed, maintenance-free, valve-regulated, lead/calcium and sulfuric acid batteries. The batteries are shipped pre-charged and ready to be put into service. Do not attempt to open these batteries for any reason.

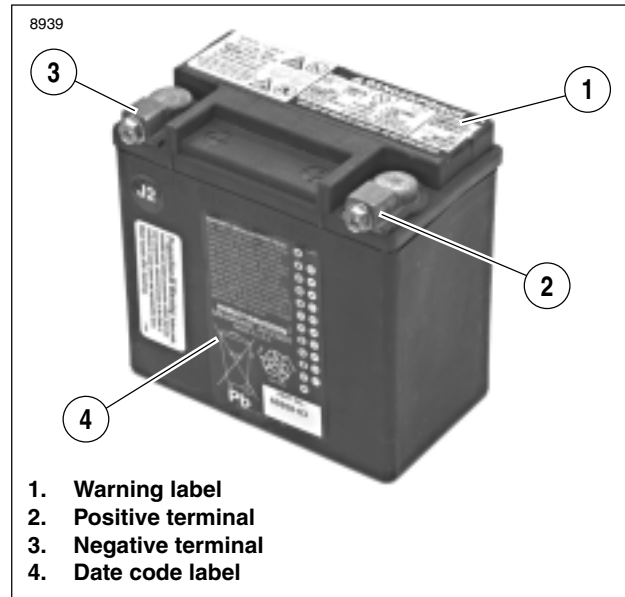

1. Warning label
2. Positive terminal
3. Negative terminal
4. Date code label

Figure 1-8. Battery

f2180x3x

1. Contents are corrosive

2. Wear safety glasses

3. Contents are explosive

4. Keep flames away

5. Read instructions

6. Keep away from children

Figure 1-9. Battery Warning Label

**Table 1-5. Battery Electrolyte Antidotes**

CONTACT	SOLUTION
External	Flush with water.
Internal	Drink large quantities of milk or water, followed by milk of magnesia, vegetable oil or beaten eggs. Call doctor immediately.
Eyes	Flush with water, get immediate medical attention.

## LEFT SIDE COVER

See [Figure 1-10](#). Removal of the left side cover provides access to the battery, fuses and various accessory and diagnostic electrical connectors. No tools are required to remove or replace the cover.

### Removal

1. See [Figure 1-11](#). Grasp left side cover at upper corners and gently pull away from plastic mounting clips (5) on frame.
2. Lift cover up slightly so mounting grommet (item 2, [Figure 1-10](#).) clears mounting tab (item 6, [Figure 1-11](#).) on battery tray. Remove cover.

### Installation

1. Place bottom of side cover with grommet (item 2, [Figure 1-10](#).) onto mounting tab on battery tray (item 6, [Figure 1-11](#).)
2. Line up top of side cover with mounting clips (item 5, [Figure 1-11](#).), aligning with front clip first. Press top of side cover into clips until snug.

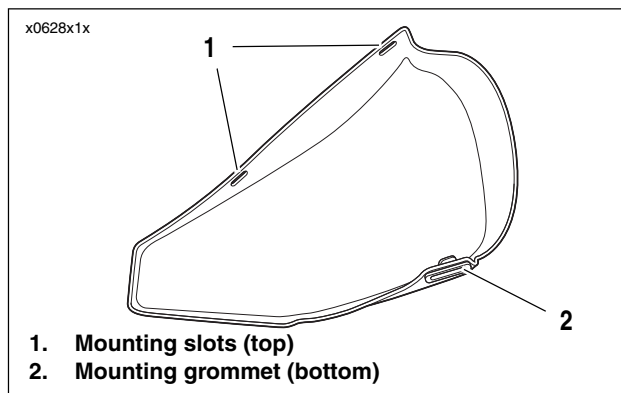

**Figure 1-10. Left Side Cover**

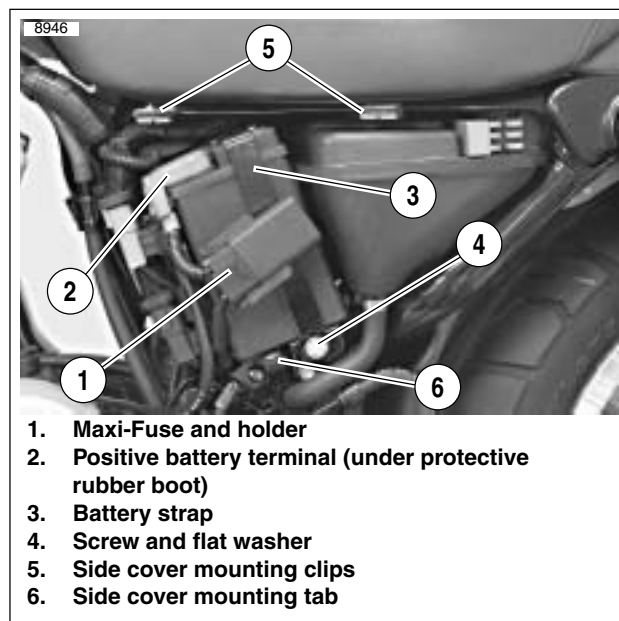

**Figure 1-11. Maxi-Fuse and Battery Location**

## BATTERY DISCONNECTION AND REMOVAL

1. Remove left side cover.
2. See [Figure 1-11](#). Remove Maxi-Fuse and holder (1) from battery strap (3) by grasping holder and sliding it toward the rear of the motorcycle. Then remove Maxi-Fuse holder from its mounting pin on battery strap.
3. Remove battery strap screw and flat washer (4). Unhook battery strap from battery tray mount on top of battery and remove strap.

### WARNING

**Prevent accidental vehicle start-up, which could cause death or serious injury. First disconnect negative (-) battery cable at engine and then positive (+) cable from battery. (00280b)**

4. See [Figure 1-12](#). Remove nut (2) that secures negative (-) battery cable (1) to stud on crankcase boss behind starter motor assembly (3).

### WARNING

**Make sure negative battery cable does not touch any grounded point on the motorcycle while disconnecting the cables from the battery positive terminal in the next step. If the positive cables should contact ground with the negative cable grounded, the resulting sparks may cause a battery explosion which could result in death or serious injury.**

5. See [Figure 1-11](#). Lift up protective rubber boot covering battery positive terminal (2). Unthread screw from battery positive (+) terminal and remove positive battery cables.
6. Remove battery from battery tray. Note routing of negative battery cable around frame downtube.

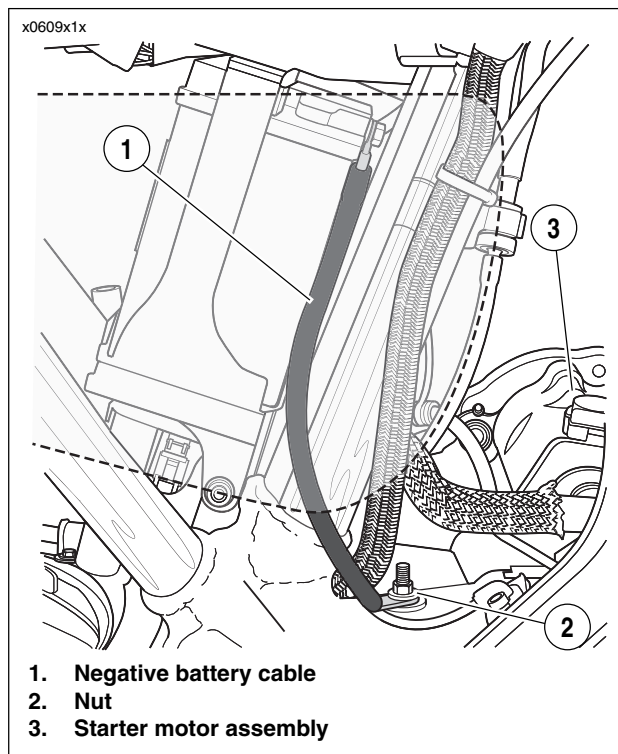

Figure 1-12. Negative Battery Connection

## BATTERY INSPECTION

1. Battery top must be clean and dry. Dirt and electrolyte on top of the battery can cause battery to self-discharge. Clean battery top with a solution of baking soda (sodium bicarbonate) and water (5 teaspoons baking soda per quart or liter of water). When the solution stops bubbling, rinse off the battery with clean water.
2. Clean cable connectors and battery terminals using a wire brush or sandpaper. Remove any oxidation.
3. Inspect the battery screws, clamps and cables for breakage, loose connections and corrosion. Clean clamps.
4. Check the battery posts for melting or damage caused by overtightening.
5. Inspect the battery for discoloration, raised top or a warped or distorted case, which might indicate that the battery has been frozen, overheated or overcharged.
6. Inspect the battery case for cracks or leaks.

## BATTERY STORAGE

### CAUTION

Store the battery out of the reach of children. Inadequate safety precautions may result in minor or moderate injury.

### CAUTION

Do not allow battery to completely discharge. The electrolyte in a discharged battery will freeze. The more discharged a battery is, the more easily it can freeze and crack the battery case. (00218a)

If the motorcycle will not be operated for several months, such as during the winter season, remove the battery from the motorcycle and fully charge.

See [Figure 1-13](#). Self-discharge is a normal condition and occurs continuously at a rate that depends on the ambient temperature and the battery's state of charge. Batteries discharge at a faster rate at higher ambient temperatures. To reduce the self-discharge rate, store battery in a cool (not freezing), dry place.

Charge the battery every month if stored at temperatures below 60° F (16° C). Charge the battery more frequently if stored in a warm area above 60° F (16° C).

#### NOTE

The GLOBAL BATTERY CHARGER (Part No. 99863-01) may be used to maintain battery charge for extended periods of time without risk of overcharging or boiling.

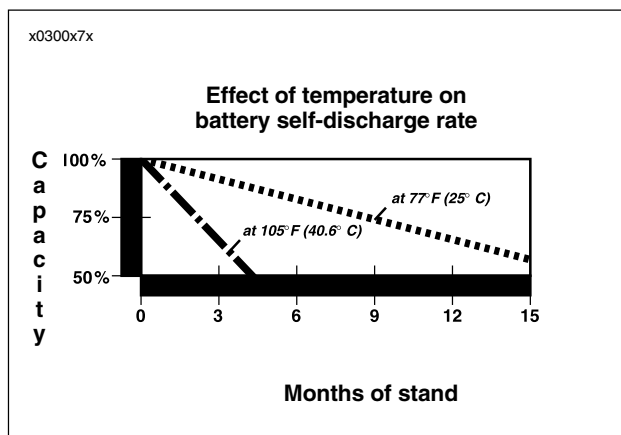

Figure 1-13. Battery Self-Discharge Rate

## BATTERY INSTALLATION AND CONNECTION

1. If negative battery cable was removed from battery, insert screw through negative (-) battery cable and into negative battery terminal. Thread screw into terminal. Position negative battery cable so that it hangs straight down from negative battery terminal. Tighten screw to 40-50 **in-lbs** (4.5-5.7 Nm).
2. Apply a light coat of petroleum jelly or corrosion retardant material to the negative battery terminal.
3. Place fully charged battery in battery tray. Route negative (-) battery cable around frame downtube.

### WARNING

Connect positive (+) battery cable first. If positive (+) cable should contact ground with negative (-) cable connected, the resulting sparks can cause a battery explosion, which could result in death or serious injury. (00068a)

4. See [Figure 1-11](#). With negative battery cable disconnected from grounding point on crankcase, insert screw through positive (+) battery cables: through maxi-fuse cable first, then through main battery cable, and into positive battery terminal (2). Thread screw into terminal. Tighten to 40-50 **in-lbs** (4.5-5.7 Nm).
5. Apply a light coat of petroleum jelly or corrosion retardant material to the positive battery terminal. Place protective rubber boot over terminal.
6. Hook top of battery strap (3) to battery tray mount on top of battery. Install flat washer and strap screw (4). Tighten to 36-60 **in-lbs** (4.1-6.8 Nm).
7. Route main positive battery cable through holders on electrical bracket.
8. Hook Maxi-Fuse holder (1) to pin on battery strap and slide forward until it snaps into place.
9. See [Figure 1-12](#). Place negative battery cable end (1) onto stud on crankcase boss behind starter motor assembly (3). Thread nut (2) onto stud. Tighten to 55-75 **in-lbs** (6.2-8.5 Nm).
10. Install left side cover.

## GENERAL

The front and rear brakes are fully hydraulic disc brake systems that require little maintenance. The front brake master cylinder is an integral part of the brake hand lever assembly. The rear brake master cylinder is located at the rear of the motorcycle's frame, beneath the rear fork pivot point.

## INSPECTION

Check the master cylinder reservoirs for proper fluid levels. With the reservoir in a level position, add **Harley-Davidson D.O.T. 5 SILICONE HYDRAULIC BRAKE FLUID (P/N 99902-77)** from a sealed container until the fluid level is within approximately 1/4-inch (6 mm) below the top edge of the reservoir (front brake) or reaches the upper fluid level in the reservoir (rear brake). Do not overfill the reservoir.

Check brake pads and discs for wear. Replace brake pads if friction material is worn to 0.04 in. (1.02 mm) or less. Minimum brake disc thickness is stamped on side of disc. Replace any brake disc that is worn beyond this limit. Maximum brake rotor lateral runout and warpage is 0.008 in. (0.2 mm) when measured near the outside diameter.

- For disc replacement procedures, see [FRONT WHEEL](#) or [REAR WHEEL](#) under [2.4 WHEELS](#).
- For brake master cylinder service, see [2.11 FRONT BRAKE MASTER CYLINDER](#) or [2.12 REAR BRAKE MASTER CYLINDER](#).
- For brake caliper service, see [2.14 FRONT BRAKE CALIPER](#) or [2.15 REAR BRAKE CALIPER](#).
- For brake line replacement procedures, see [2.16 BRAKE LINES](#).

### ⚠ WARNING

Use denatured alcohol to clean brake system components. Do not use mineral-based solvents (such as gasoline or paint thinner), which will deteriorate rubber parts even after assembly. Deterioration of these components can cause brake failure, which could result in death or serious injury. (00291a)

### ⚠ WARNING

After repairing the brake system, test brakes at low speed. If brakes are not operating properly, testing at high speeds can cause loss of control, which could result in death or serious injury. (00289a)

### ⚠ WARNING

Direct contact of D.O.T. 5 brake fluid with eyes can cause eye irritation, swelling, and redness. Avoid eye contact. In case of eye contact flush with large amounts of water and get medical attention. Swallowing large amounts of D.O.T. 5 brake fluid can cause digestive discomfort. If swallowed, obtain medical attention. Use in well ventilated area. KEEP OUT OF REACH OF CHILDREN. (00144a)

## TROUBLESHOOTING

Use the following troubleshooting guide to help in determining probable causes of poor brake operation.

**Table 1-6. Troubleshooting Brakes**

CONDITION	CHECK FOR	REMEDY
Excessive lever or pedal travel or spongy feel.	<ul style="list-style-type: none"> <li>● Air in system.</li> <li>● Master cylinder reservoir low on fluid.</li> </ul>	<ul style="list-style-type: none"> <li>● Bleed brake system.</li> <li>● Fill master cylinder reservoir with approved brake fluid. Bleed brake system.</li> </ul>
Chattering sound when brake is applied.	<ul style="list-style-type: none"> <li>● Worn brake pads.</li> <li>● Loose mounting bolts.</li> <li>● Warped brake disc.</li> </ul>	<ul style="list-style-type: none"> <li>● Replace brake pads.</li> <li>● Tighten bolts.</li> <li>● Replace brake disc.</li> </ul>
Ineffective brake – lever or pedal travels to limit.	<ul style="list-style-type: none"> <li>● Low fluid level.</li> <li>● Piston cup not functioning.</li> </ul>	<ul style="list-style-type: none"> <li>● Fill master cylinder reservoir with approved brake fluid, and bleed brake system.</li> <li>● Rebuild master cylinder.</li> </ul>
Ineffective brake – lever or pedal travel normal.	<ul style="list-style-type: none"> <li>● Distorted or glazed brake disc.</li> <li>● Distorted, glazed or contaminated brake pads.</li> </ul>	<ul style="list-style-type: none"> <li>● Replace brake disc.</li> <li>● Replace brake pads.</li> </ul>
Brake pads drag on disc – will not retract.	<ul style="list-style-type: none"> <li>● Cup in master cylinder not uncovering relief port.</li> </ul>	<ul style="list-style-type: none"> <li>● Inspect master cylinder.</li> </ul>

## GENERAL

Bleed the hydraulic brake system any time a hydraulic brake line, brake master cylinder or brake caliper has been opened, or whenever brake lever/pedal operation feels “spongy.” Bleeding evacuates air from the system leaving only incompressible hydraulic fluid.

### ⚠ WARNING

Direct contact of D.O.T. 5 brake fluid with eyes can cause eye irritation, swelling, and redness. Avoid eye contact. In case of eye contact flush with large amounts of water and get medical attention. Swallowing large amounts of D.O.T. 5 brake fluid can cause digestive discomfort. If swallowed, obtain medical attention. Use in well ventilated area. KEEP OUT OF REACH OF CHILDREN. (00144a)

### NOTE

Hydraulic brake fluid bladder-type pressure equipment can be used to fill brake master cylinders through the bleeder valve. Remove master cylinder reservoir cover so that system cannot pressurize. Do not use pressure bleeding equipment when the hydraulic system is sealed with master cylinder reservoir cover and gasket in place.

## BLEEDING FRONT BRAKE

1. See [Figure 1-14](#). Position motorcycle so that top of front master cylinder reservoir (1) is level.
2. See [Figure 1-15](#). Remove reservoir cover (4) with two captive screws (5), diaphragm plate (3) and diaphragm (2) from master cylinder reservoir (1).

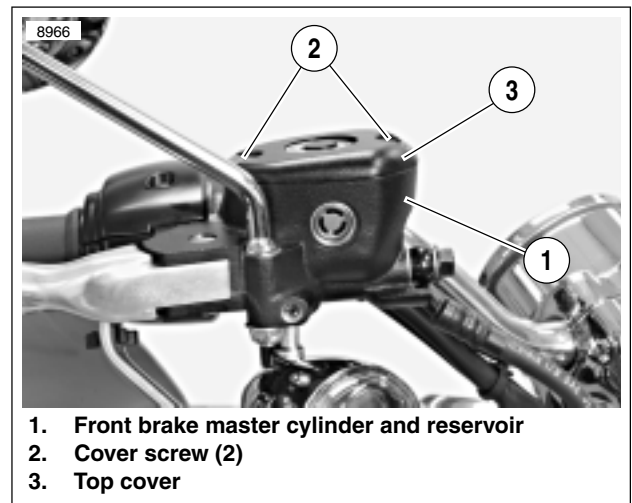

Figure 1-14. Front Brake Master Cylinder Reservoir

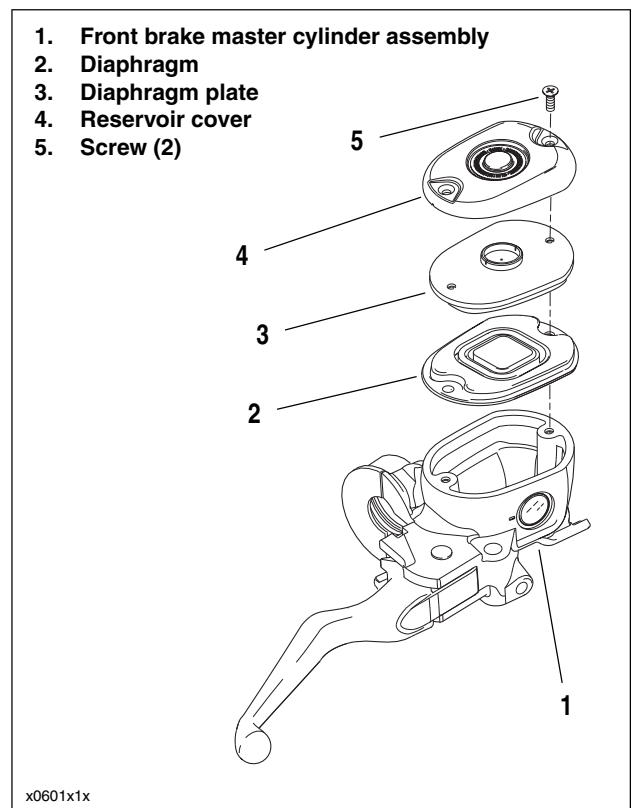

Figure 1-15. Front Brake Master Cylinder Cover Assembly



**Suggest:**

**For more complete manuals. Please go to the home page.**

**<https://www.ebooklibonline.com>**

**If the above button click is invalid. Please download this document first, and then click the above link to download the complete manual.**

**Thank you so much for reading**

## NOTES

- See [Figure 1-16](#). Do not use sight glass to determine maximum fluid level. Sight glass should only be used as a visual indicator that fluid level is low and needs attention. A ridge is cast into the inside of the reservoir to assist you in determining the correct level.
- Use only Harley-Davidson D.O.T. 5 SILICONE HYDRAULIC BRAKE FLUID from a sealed container.
- Do not overfill reservoir. Do not reuse old brake fluid.



**Figure 1-16. Filling Front Master Cylinder Reservoir**

3. See [Figure 1-16](#). Add enough Harley-Davidson D.O.T. 5 SILICONE HYDRAULIC BRAKE FLUID (Part No. 99902-77) to reservoir to bring fluid level even with ridge cast into inside of reservoir, about 1/4-inch (6 mm) below top edge.
4. See [Figure 1-17](#). Remove bleeder cap (3) from bleeder valve (2) on front caliper (1).
5. See [Figure 1-18](#). Install end of a length of plastic tubing over caliper bleeder valve. Place free end of tube in a clean container.
6. Squeeze and hold brake lever to build up hydraulic pressure. See [Figure 1-17](#). Open bleeder valve (2) about 1/2-turn. Brake fluid will flow from bleeder valve through tubing. Close bleeder valve when brake lever has moved 1/2 to 3/4 of its full range of travel. Allow brake lever to return slowly to its released position.
7. Repeat Step 6 until all air bubbles are purged.
8. Final tighten bleeder valve to 35-61 **in-lbs** (3.9-6.9 Nm). Remove plastic tubing and install bleeder cap (3).
9. See [Figure 1-16](#). Add enough Harley-Davidson D.O.T. 5 SILICONE HYDRAULIC BRAKE FLUID (Part No. 99902-77) to reservoir to bring fluid level even with ridge cast into inside of reservoir, about 1/4-inch (6 mm) below top edge.

10. If bleeding dual front disc brake system, repeat this procedure for other caliper.
11. See [Figure 1-15](#). Replace diaphragm (2), diaphragm plate (3) and reservoir cover (4) with captive screws (5). Tighten to 9-17 **in-lbs** (1.0-2.0 Nm).

**⚠ WARNING**

**After repairing the brake system, test brakes at low speed. If brakes are not operating properly, testing at high speeds can cause loss of control, which could result in death or serious injury. (00289a)**

12. Test ride motorcycle at low speed. Repeat the above bleeding procedure if front brake feels spongy.

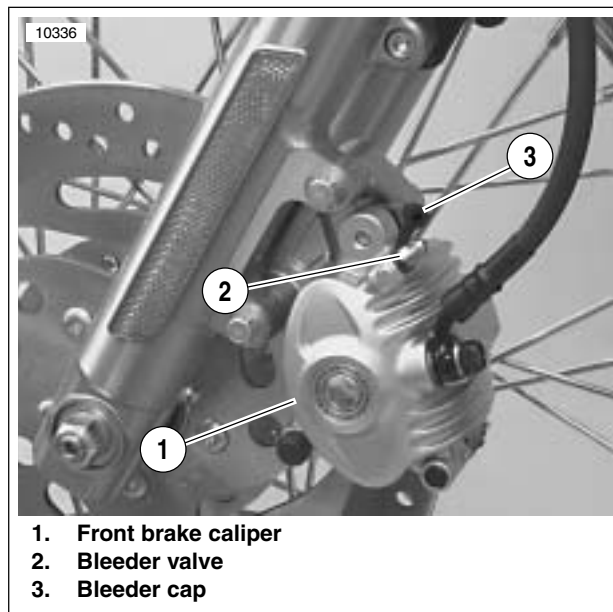

**Figure 1-17. Front Brake Caliper**

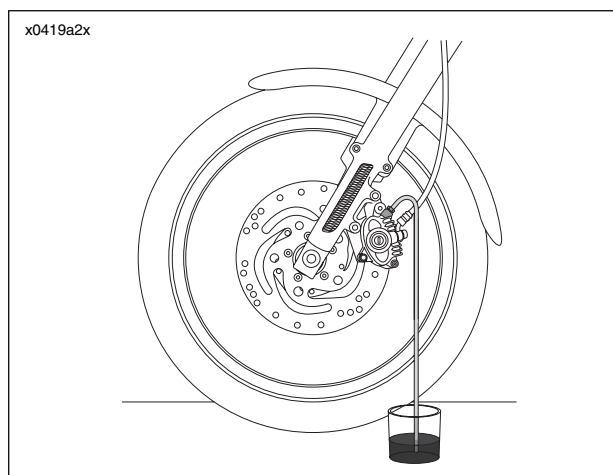

**Figure 1-18. Bleeding Hydraulic System**

## BLEEDING REAR BRAKE

### NOTES

- See [Figure 1-19](#). Rear brake master cylinder reservoir (1) must be in a level position when filling and checking fluid level.
  - Reservoir cover (5) may be removed from rear brake master cylinder reservoir to more easily verify fluid level in reservoir.
  - Use only Harley-Davidson D.O.T. 5 SILICONE HYDRAULIC BRAKE FLUID from a sealed container.
  - Do not overfill reservoir. Do not reuse old brake fluid.
1. Position motorcycle upright (not resting on jiffy stand). See [Figure 1-19](#). Unscrew and remove reservoir cap (2).
  2. Add Harley-Davidson D.O.T. 5 SILICONE HYDRAULIC BRAKE FLUID to master cylinder reservoir (1) until the fluid reaches the upper fluid level (3).
  3. See [Figure 1-20](#). Remove bleeder cap (3). Install end of a length of plastic tubing over caliper bleeder valve (2). Place free end of tube in a clean container.
  4. Depress and hold brake pedal to build up hydraulic pressure. Open bleeder valve about 1/2-turn. Brake fluid will flow from bleeder valve through tubing. Close bleeder valve when brake pedal has moved 1/2 to 3/4 of its full range of travel. Allow brake pedal to return slowly to its released position.
  5. Repeat Step 4 until all air bubbles are purged.
  6. Final tighten bleeder valve to 35-61 in-lbs (3.9-6.9 Nm). Remove plastic tubing and install bleeder cap.
  7. See [Figure 1-19](#). Add Harley-Davidson D.O.T. 5 SILICONE HYDRAULIC BRAKE FLUID to master cylinder reservoir (1) until the fluid reaches the upper fluid level (3).
  8. Replace reservoir cap (2). Replace reservoir cover (5) if removed.

### WARNING

After repairing the brake system, test brakes at low speed. If brakes are not operating properly, testing at high speeds can cause loss of control, which could result in death or serious injury. (00289a)

9. Test ride motorcycle at low speed. Repeat the above bleeding procedure if rear brake feels spongy.

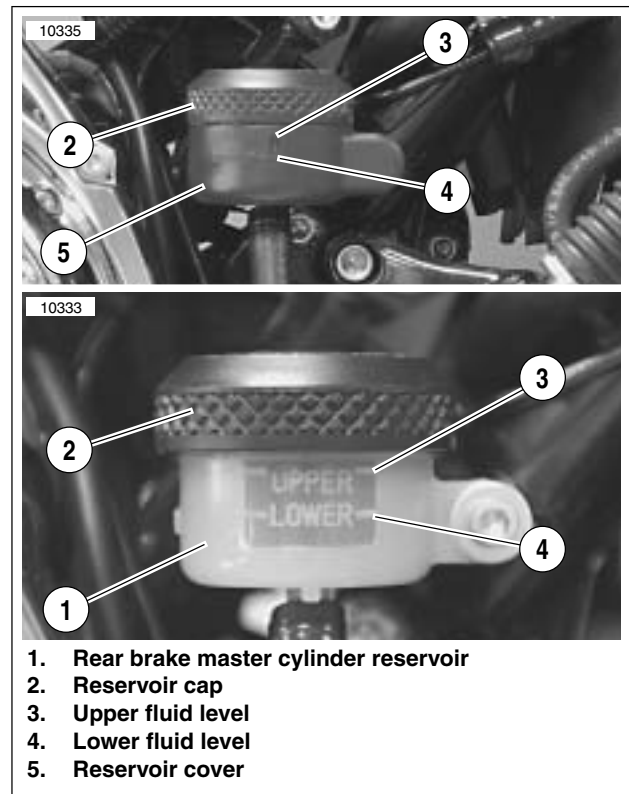

Figure 1-19. Rear Brake Master Cylinder Reservoir

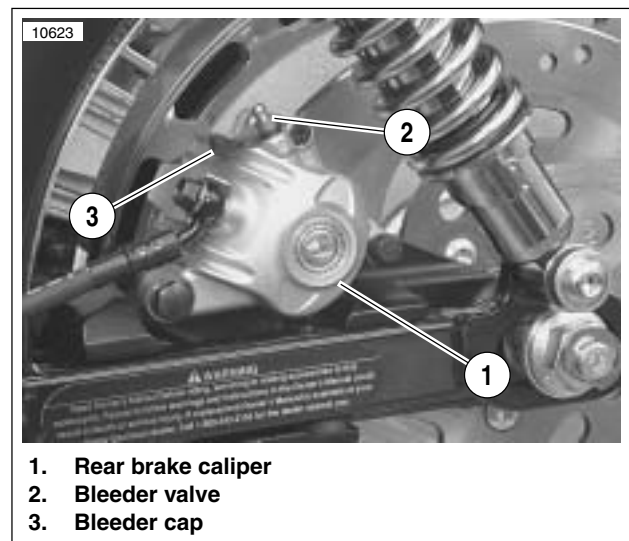

Figure 1-20. Rear Brake Caliper

**<https://www.ebooklibonline.com>**

Hello dear friend!

Thank you very much for reading.

Enter the link into your browser.

The full manual is available for immediate download.

**<https://www.ebooklibonline.com>**