

2005 SOFTAIL MODELS

SERVICE MANUAL

Part Number 99482-05

Section 1: Maintenance

Section 2: Chassis

Section 3: Engine

Section 4: Fuel System

Section 5: Starter

Section 6: Drive

Section 7: Transmission

Section 8: Electrical

Section 9: Fuel Injection

Appendix

ELECTRICAL DIAGNOSTICS

Part Number 99498-05

Section 1: Starting & Charging

Section 2: Instruments

Section 3: TSM & TSSM

Section 4: Engine Management (Carbureted)

Section 5: Engine Management (EFI)

Section 6: Wiring

FLSTFSE SERVICE SUPPLEMENT

Part Number 99494-05

Section 1: Maintenance

Section 2: Chassis

Section 3: Engine

Section 4: Fuel System (No content)

Section 5: Starter

Section 6: Drive

Section 7: Transmission

Section 8: Electrical

Section 9: Fuel Injection (No content)

Table Of Contents

SUBJECT	PAGE NO.
1.1 General	1-1
1.2 Fuel and Oil	1-5
1.3 Maintenance Schedule	1-6
1.4 Engine Oil and Filter	1-11
1.5 Battery Maintenance	1-13
1.6 Brakes	1-16
1.7 Bleeding Brakes	1-18
1.8 Brake Pads and Discs	1-19
1.9 Tires and Wheels	1-23
1.10 Primary Chain	1-25
1.11 Primary Chaincase Lubricant	1-26
1.12 Clutch	1-28
1.13 Transmission Lubricant	1-30
1.14 Rear Belt Deflection	1-31
1.15 Rear Belt and Sprockets	1-32
1.16 Suspension Adjustments	1-34
1.17 Steering Head Bearings: All But FLSTSC/FXSTS	1-35
1.18 Steering Head Bearings: FLSTSC/FXSTS	1-36
1.19 Rocker Bearings: FLSTSC/FXSTS	1-39
1.20 Front Fork Oil	1-41
1.21 Spark Plugs	1-43
1.22 Air Cleaner Filter	1-44
1.23 Cable and Chassis Lubrication	1-46
1.24 Throttle Cables	1-47
1.25 Enrichener: Carbureted	1-49
1.26 Idle Speed and Ignition Timing: Carbureted	1-50
1.27 Fuel Supply Valve Filter: Carbureted	1-51
1.28 Engine Mounts	1-53
1.29 Headlamp Alignment	1-54
1.30 Critical Fasteners	1-56
1.31 Storage	1-57
1.32 Troubleshooting	1-59

SERVICING A NEW MOTORCYCLE

WARNING

Always follow the listed service and maintenance recommendations, since they affect the safe operation of the motorcycle and the personal welfare of the rider. Failure to follow recommendations could result in death or serious injury.

Service operations to be performed before customer delivery are specified in the applicable model year PREDELIVERY AND SETUP MANUAL.

The performance of new motorcycle initial service is required to keep warranty in force and to ensure proper emissions systems operation. See [FIRST SCHEDULED MAINTENANCE](#) under [1.3 MAINTENANCE SCHEDULE](#) for details.

SAFE OPERATING MAINTENANCE

CAUTION

- Do not attempt to retighten engine head bolts. Retightening can cause engine damage.
- During the initial break-in period, use only Harley-Davidson 20W50 engine oil. Failure to use the recommended oil will result in improper break-in of the engine cylinders and piston rings.

A careful check of certain equipment is necessary after periods of storage, and frequently between regular service intervals, to determine if additional maintenance is required.

Check:

1. Tires for abrasions, cuts and correct pressure.
2. Secondary drive belt for proper tension and condition.
3. Brakes, steering and throttle for responsiveness.
4. Brake fluid level and condition. Hydraulic lines and fittings for leaks. Also, check brake pads and rotors for wear.
5. Cables for fraying, crimping and free operation.
6. Engine oil and transmission fluid levels.
7. Headlamp, auxiliary lamp, tail lamp, brake lamp and turn signal operation.

SHOP PRACTICES

Repair Notes

NOTE

- General maintenance practices are given in this section.
- Repair = Disassembly/Assembly.
- Replace = Removal/Installation.

All special tools and torque values are noted at the point of use.

All required parts or materials can be found in the appropriate PARTS CATALOG.

Safety

Safety is always the most important consideration when performing any job. Be sure you have a complete understanding of the task to be performed. Use common sense. Use the proper tools. Protect yourself and bystanders with approved eye protection. Don't just do the job – do the job safely.

Removing Parts

Always consider the weight of a part when lifting. Use a hoist whenever necessary. Do not lift heavy parts by hand. A hoist and adjustable lifting beam or sling are needed to remove some parts. The lengths of chains or cables from the hoist to the part should be equal and parallel and should be positioned directly over the center of the part. Be sure that no obstructions will interfere with the lifting operation. Never leave a part suspended in mid-air.

WARNING

Always check the capacity rating and condition of hoists, slings, chains or cables before use. Failure to do so can lead to an accident which could result in death or serious injury.

Always use blocking or proper stands to support the part that has been hoisted. If a part cannot be removed, verify that all bolts and attaching hardware have been removed. Check to see if any parts are in the way of the part being removed.

When removing hoses, wiring or tubes, always tag each part to ensure proper installation.

<https://www.ebooklibonline.com>

Hello dear friend!

Thank you very much for reading.

Enter the link into your browser.

The full manual is available for immediate download.

<https://www.ebooklibonline.com>

Cleaning

If you intend to reuse parts, follow good shop practice and thoroughly clean the parts before assembly. Keep all dirt out of parts; the unit will perform better and last longer. Seals, filters and covers are used in this vehicle to keep out environmental dirt and dust. These items must be kept in good condition to ensure satisfactory operation.

Clean and inspect all parts as they are removed. Be sure all holes and passages are clean and open. After cleaning, cover all parts with clean lint-free cloth, paper or other material. Be sure the part is clean when it is installed.

Always clean around lines or covers before they are removed. Plug, tape or cap holes and openings to keep out dirt, dust and debris.

Disassembly and Assembly

Always assemble or disassemble one part at a time. Do not work on two assemblies simultaneously. Be sure to make all necessary adjustments. Recheck your work when finished. Be sure that everything is done.

Operate the vehicle to perform any final check or adjustments. If all is correct, the vehicle is ready to go back to the customer.

REPAIR AND REPLACEMENT PROCEDURES

Hardware and Threaded Parts

Install helical thread inserts when inside threads in castings are stripped, damaged or not capable of withstanding specified torque.

Replace bolts, nuts, studs, washers, spacers and small common hardware if missing or in any way damaged. Clean up or repair minor thread damage with a suitable thread chaser.

Replace all damaged or missing lubrication fittings.

Use Teflon pipe sealant on pipe fitting threads.

Wiring, Hoses and Lines

Replace hoses, clamps, electrical wiring, electrical switches or fuel lines if they do not meet specifications.

Instruments and Gauges

Replace broken or defective instruments and gauges. Replace dials and glass that are so scratched or discolored that reading is difficult.

Bearings

Anti-friction bearings must be handled in a special way. To keep out dirt and abrasives, cover the bearings as soon as they are removed from the package.

Wash bearings in a non-flammable cleaning solution. Knock out packed lubricant inside by tapping the bearing against a wooden block. Wash bearings again. Cover bearings with clean material after setting them down to dry. Never use compressed air to dry bearings.

Coat bearings with clean oil. Wrap bearings in clean paper.

Be sure that the chamfered side of the bearing always faces the shoulder (when bearings installed against shoulders). Lubricate bearings and all metal contact surfaces before pressing into place. Only apply pressure on the part of the bearing that makes direct contact with the mating part. Install bearings with numbered side facing out.

Always use the proper tools and fixtures for removing and installing bearings.

Bearings do not usually need to be removed. Only remove bearings if necessary.

Bushings

Do not remove a bushing unless damaged, excessively worn or loose in its bore. Press out bushings that must be replaced.

When pressing or driving bushings, be sure to apply pressure in line with the bushing bore. Use a bearing/bushing driver or a bar with a smooth, flat end. Never use a hammer to drive bushings.

Inspect the bushing and the mated part for oil holes. Be sure all oil holes are properly aligned.

Gaskets

Always discard gaskets after removal. Replace with **new** gaskets. Never use the same gasket twice. Be sure that gasket holes match up with holes in the mating part.

Lip Type Seals

Lip seals are used to seal oil or grease and are usually installed with the sealing lip facing the contained lubricant. Seal orientation, however, may vary under different applications.

Seals should not be removed unless necessary. Only remove seals if required to gain access to other parts or if seal damage or wear dictates replacement.

Leaking oil or grease usually means that a seal is damaged. Replace leaking seals to prevent overheated bearings.

Always discard seals after removal. Do not use the same seal twice.

O-Rings (Preformed Packings)

Always discard O-rings after removal. Replace with **new** O-rings. To prevent leaks, lubricate the O-rings before installation. Apply the same type of lubricant as that being sealed. Be sure that all gasket, O-ring and seal mating surfaces are thoroughly clean before installation.

Gears

Always check gears for damaged or worn teeth.

Lubricate mating surfaces before pressing gears on shafts.

Shafts

If a shaft does not come out easily, check that all nuts, bolts or retaining rings have been removed. Check to see if other parts are in the way before using force.

Shafts fitted to tapered splines should be very tight. If shafts are not tight, disassemble and inspect tapered splines. Discard parts that are worn. Be sure tapered splines are clean, dry and free of burrs before putting them in place. Press mating parts together tightly.

Clean all rust from the machined surfaces of new parts.

Part Replacement

Always replace worn or damaged parts with **new** parts.

CLEANING

Part Protection

Before cleaning, protect rubber parts (such as hoses, boots and electrical insulation) from cleaning solutions. Use a grease-proof barrier material. Remove the rubber part if it cannot be properly protected.

Cleaning Process

Any cleaning method may be used as long as it does not result in parts damage. Thorough cleaning is necessary for proper parts inspection. Strip rusted paint areas to bare metal before repainting.

Rust or Corrosion Removal

Remove rust and corrosion with a wire brush, abrasive cloth, sand blasting, vapor blasting or rust remover. Use buffing crocus cloth on highly polished parts that are rusted.

TOOL SAFETY

Air Tools

- Always use approved eye protection equipment when performing any task using air-operated tools.
- On all power tools, use only recommended accessories with proper capacity ratings.
- Do not exceed air pressure ratings of any power tools.
- Bits should be placed against work surface before air hammers are operated.
- Disconnect the air supply line to an air hammer before attaching a bit.
- Never point an air tool at yourself or another person.
- Protect bystanders with approved eye protection.

Wrenches

- Never use an extension on a wrench handle.
- If possible, always pull on a wrench handle and adjust your stance to prevent a fall if something lets go.
- Never cock a wrench.
- Never use a hammer on any wrench other than a STRIKING FACE wrench.
- Discard any wrench with broken or battered points.
- Never use a pipe wrench to bend, raise or lift a pipe.

Pliers/cutters/prybars

- Plastic- or vinyl-covered pliers handles are not intended to act as insulation; don't use on live electrical circuits.
- Don't use pliers or cutters for cutting hardened wire unless they were designed for that purpose.
- Always cut at right angles.
- Don't use any prybar as a chisel, punch or hammer.

Hammers

- Never strike one hammer against a hardened object, such as another hammer.
- Always grasp a hammer handle firmly, close to the end.
- Strike the object with the full face of the hammer.
- Never work with a hammer which has a loose head.
- Discard hammer if face is chipped or mushroomed.
- Wear approved eye protection when using striking tools.
- Protect bystanders with approved eye protection.

Punches/chisels

- Never use a punch or chisel with a chipped or mushroomed end; dress mushroomed chisels and punches with a file.
- Hold a chisel or a punch with a tool holder if possible.
- When using a chisel on a small piece, clamp the piece firmly in a vise and chip toward the stationary jaw.
- Wear approved eye protection when using these tools.
- Protect bystanders with approved eye protection.

Screwdrivers

- Don't use a screwdriver for prying, punching, chiseling, scoring or scraping.
- Use the right type of screwdriver for the job; match the tip to the fastener.
- Don't interchange POZIDRIV®, PHILLIPS® or REED AND PRINCE screwdrivers.
- Screwdriver handles are not intended to act as insulation; don't use on live electrical circuits.
- Don't use a screwdriver with rounded edges because it will slip – redress with a file.

Ratchets and Handles

- Periodically clean and lubricate ratchet mechanisms with a light grade oil. Do not replace parts individually; ratchets should be rebuilt with the entire contents of service kit.
- Never hammer or put a pipe extension on a ratchet or handle for added leverage.
- Always support the ratchet head when using socket extensions, but do not put your hand on the head or you may interfere with the action of its reversing mechanism.
- When breaking loose a fastener, apply a small amount of pressure as a test to be sure the ratchet's gear wheel is engaged with the pawl.

Sockets

- Never use hand sockets on power or impact wrenches.
- Select the right size socket for the job.
- Never cock any wrench or socket.
- Select only impact sockets for use with air or electric impact wrenches.
- Replace sockets showing cracks or wear.
- Keep sockets clean.
- Always use approved eye protection when using power or impact sockets.

Storage Units

- Don't open more than one loaded drawer at a time. Close each drawer before opening up another.
- Close lids and lock drawers and doors before moving storage units.
- Don't pull on a tool cabinet; push it in front of you.
- Set the brakes on the locking casters after the cabinet has been rolled to your work.

FUEL

WARNING

Avoid spills. Slowly remove filler cap. Do not fill above bottom of filler neck insert, leaving air space for fuel expansion. Secure filler cap after refueling. Gasoline is extremely flammable and highly explosive, which could result in death or serious injury. (00028a)

Use a good quality leaded or unleaded gasoline (91 pump octane or higher). Pump octane is the octane number usually shown on the gas pump.

GASOLINE BLENDS

CAUTION

Using gasoline that has an alcohol additive, such as methanol, may cause fuel system rubber components' failure and/or engine damage.

Harley-Davidson motorcycles were designed to give the best performance using unleaded gasoline. Some fuel suppliers sell gasoline/alcohol blends as a fuel. The type and amount of alcohol added to the fuel is important.

- **DO NOT USE GASOLINES CONTAINING METHANOL.** Using gasoline/methanol blends will result in starting and driveability deterioration and damage to critical fuel system components.
- **ETHANOL** is a mixture of 10% ethanol (Grain alcohol) and 90% unleaded gasoline. Gasoline/ethanol blends can be used in your motorcycle if the ethanol content does not exceed 10%.
- **REFORMULATED OR OXYGENATED GASOLINES (RFG):** "Reformulated gasoline" is a term used to describe gasoline blends that are specifically designed to burn cleaner than other types of gasoline. Your motorcycle will run normally using this type of gas.

You may find that some gasoline blends adversely affect the starting, driveability or fuel efficiency of your bike. If you experience one or more of these problems, we recommend you try a different brand of gasoline or gasoline with a higher octane rating.

ENGINE OIL

Use the proper grade of oil for the lowest temperature expected before the next oil change.

If it is necessary to add oil and Harley-Davidson oil is not available, use an oil certified for diesel engines. Acceptable diesel engine oil designations include CF, CF-4, CG-4 and CH-4. The preferred viscosities for the diesel engine oils, in descending order, are 20W-50, 15W-40 and 10W-40. At the first opportunity, see a Harley-Davidson dealer to change back to 100 percent Harley-Davidson oil.

See [1.4 ENGINE OIL AND FILTER](#) for all service information.

WINTER LUBRICATION

Combustion in an engine produces water vapor. During starting and warm-up in cold weather, especially in freezing temperatures, the vapor condenses to water before the crankcase is hot enough to exhaust it through the breather system. If the engine is run long enough for the crankcase to become thoroughly heated, the water returns to vapor and is then exhausted.

An engine used for only short trips, and seldom allowed to thoroughly warm up, accumulates increasing amounts of water in the oil pan. Water mixed with oil forms a sludge that causes accelerated engine wear. In freezing temperatures, the water becomes slush or ice, which may clog oil lines and result in engine failure.

Always change the engine oil more often in winter. If the engine is used for short runs, change the oil even more frequently. The farther below freezing the temperature drops the more often the oil should be changed.

MAINTENANCE SCHEDULE

1.3

FIRST SCHEDULED MAINTENANCE

- On models with springer forks (FLSTSC, FXSTS), after 500 miles (800 km) a Harley-Davidson dealer should perform the first scheduled service listed in the Owner's Manual. See the Maintenance and Lubrication section in your Owner's Manual for more information.
- On models with hydraulic forks (FXSTD, FLSTC, FLSTF, FXST, FXSTB, FLSTN), after 1000 miles (1600 km) a Harley-Davidson dealer should perform the first scheduled service listed in the Owner's Manual. See the Maintenance and Lubrication section in your Owner's Manual for more information.

Table 1-1. Regular Service Intervals For Softail Models

ITEM SERVICED	PROCEDURE	1000 mi	5000 mi	10,000 mi	15,000 mi	20,000 mi	25,000 mi	NOTES
		1600 km	8000 km	16,000 km	24,000 km	32,000 km	40,000 km	
Engine oil and filter	Replace	X	X	X	X	X	X	
Oil lines and brake system	Inspect for leaks	X	X	X	X	X	X	1
Air cleaner	Inspect, service as required	X	X	X	X	X	X	
Tires	Check pressure, inspect tread	X	X	X	X	X	X	
Wheel spokes	Check tightness	X	X			X		1, 4
Primary chaincase lubricant	Replace	X	X	X	X	X	X	
Transmission lubricant	Replace	X	X	X	X	X	X	
Clutch	Check adjustment	X	X	X	X	X	X	1
Primary chain	Check adjustment	X	X	X	X	X	X	
Rear belt and sprockets	Inspect, adjust belt	X	X	X	X	X	X	1
Throttle, brake, enricher and clutch controls	Check, adjust and lubricate	X	X	X	X	X	X	1, 4
Jiffy stand	Inspect and lubricate	X		X		X		1
Fuel valve, lines and fittings	Inspect for leaks	X	X	X	X	X	X	1, 4
Fuel tank filter screen	Clean (EFI: replace)						X	1
Brake fluid	Check levels and condition	X	X	X	X	X	X	
Brake pads and discs	Inspect for wear	X	X	X	X	X	X	
Spark plugs	Inspect	X	X		X		X	
	Replace			X		X		
Electrical equipment and switches	Check operation	X	X	X	X	X	X	
Engine idle speed	Check adjustment	X	X	X	X	X	X	1
Front fork oil	Replace					X		1

NOTES:

1. Should be performed by an authorized Harley-Davidson dealer, unless you have the proper tools, service data and are mechanically qualified.
2. Disassemble, lubricate and inspect every 30,000 miles (48,000 km).
3. Perform annually.
4. Not all vehicles are equipped with enricher, fuel valve or spoke wheels. Consult appropriate topic in service manual.
5. Disassemble, lubricate and inspect every 20,000 miles (32,000 km).

Table 1-1. Regular Service Intervals For Softail Models

ITEM SERVICED	PROCEDURE	1000 mi	5000 mi	10,000 mi	15,000 mi	20,000 mi	25,000 mi	NOTES
		1600 km	8000 km	16,000 km	24,000 km	32,000 km	40,000 km	
Steering head bearings (Softail models)	Adjust	X		X		X		1
	Lubricate			X		X		2
Steering head bearings (Springer models)		Adjust and lubricate every 2500 miles						1, 5
Rear fork bearings (if applica- ble)	Repack					X		1
Windshield bushings	Inspect			X		X		1
Springer rocker bearings	Adjust	X		X		X		1
Fuel door, tour-pak, saddle- bags	Lubricate hinges and latches	X	X	X	X	X		
Critical fasteners	Check tightness	X		X		X		1
Battery	Check battery and clean connections							3
Road test	Verify component and system functions	X	X	X	X	X	X	

NOTES:

1. Should be performed by an authorized Harley-Davidson dealer, unless you have the proper tools, service data and are mechanically qualified.
2. Disassemble, lubricate and inspect every 30,000 miles (48,000 km).
3. Perform annually.
4. Not all vehicles are equipped with enrichener, fuel valve or spoke wheels. Consult appropriate topic in service manual.
5. Disassemble, lubricate and inspect every 20,000 miles (32,000 km).

Table 1-2. Quick Reference Maintenance Chart

ITEM SERVICED	SPECIFICATION	DATA
Engine oil and filter	Drain plug torque	14-21 ft-lbs (19-28 Nm)
	Oil capacity	4 qt. (3.8 L)
	Filter	Hand tighten 1/2-3/4 turn after gasket contact
	Chrome filter part number	63798-99
	Black filter part number	63731-99
Primary chain tension	Deflection with hot engine	5/8-7/8 in. (15.9-22.2 mm)
	Deflection with cold engine	3/8-5/8 in. (9.5-15.9 mm)
	Chain tensioner nut torque	21-29 ft-lbs (29-39 Nm)
	Primary chain inspection cover torque	84-108 in-lbs (10-12 Nm)
Primary chain lubricant	Lubricant capacity	32 oz. (946 mL)
	Primary chaincase drain plug torque	36-60 in-lbs (4-7 Nm)
Clutch adjustment	Free play at adjuster screw	1/2-1 turn
	Adjuster screw locknut torque	72-120 in-lbs (8-14 Nm)
	Free play at hand lever	1/16-1/8 (1.6-3.2 mm)
	Clutch inspection cover torque	84-108 in-lbs (10-12 Nm)
Transmission lubricant	Lubricant level	Dipstick at FULL with motorcycle level and filler plug resting on threads
	Lubricant capacity	20-24 oz (590-710 mL)
	Transmission drain plug torque	14-21 ft-lbs (19-28 Nm)
	Filler plug torque	25-75 in-lbs (3-9 Nm)
Tire condition and pressure	Pressure for solo rider	Front: 36 psi (2.5 bar) Rear: 36 psi (2.5 bar)
	Pressure for rider and passenger	Front: 36 psi (2.5 bar) Rear: 40 psi (2.8 bar)
	Wear	Replace tire if 1/32 in. (0.8 mm) or less of tread pattern remains
Wheel spokes	Spoke nipple torque	40-50 in-lbs (4.5-5.6 Nm)
Steering head bearings	Lubricant for neck fitting	SPECIAL PURPOSE GREASE Part No. 99857-97 (14 oz. cartridge)
Brake fluid reservoir level	D.O.T. hydraulic brake fluid part numbers	99902-77 (12 oz.) 99901-77 (gal)
	Proper fluid level	1/8 in. (3.2 mm) from the top
	Master cylinder reservoir cover torque	6-8 in-lbs (0.7-0.9 Nm)
Brake pad linings and discs	Minimum brake pad thickness	0.04 in. (1.02 mm)
	Minimum brake disc thickness	See stamp on side of disc

Table 1-2. Quick Reference Maintenance Chart

ITEM SERVICED	SPECIFICATION	DATA
Drive belt	Upward measurement force applied at midpoint of bottom belt strand	10 lb. (4.5 kg)
	Belt deflection with motorcycle on jiffy stand without rider or luggage and 10 psi (69 kPa) in rear shocks	1/4-5/16 in. (6.4-7.9 mm)
	Belt deflection with motorcycle upright and rear wheel in the air	3/16-1/4 in. (4.8-6.4 mm)
Air cleaner	Air cleaner cover bracket screw torque	20-40 in-lbs (2-5 Nm)
	Air cleaner cover screw torque	30-60 in-lbs (4-7 Nm)
	Adhesive for air cleaner cover screw	LOCTITE THREADLOCKER 243 Part No. 99642-97 (6 ml)
Fuel tank filter	Sealant for fuel valve and fuel tank adapter	LOCTITE PIPE SEALANT WITH TEFLON 565 Part No. 99818-97 (6 ml)
	Hex jam nut torque	15-20 ft-lbs (20-27 Nm)
Enrichener control	Hex nut torque	20-35 in-lbs (2-4 Nm)
Clutch and throttle cables	Lubricant	SUPER OIL Part No. 94968-85TV (1/4 fl. oz.)
	Handlebar clamp screw torque	60-80 in-lbs (6.8-9.0 Nm)
	Handlebar switch housing screw torque	35-45 in-lbs (4-5 Nm)
Spark plugs	Type	HD-6R12
	Gap	0.038-0.043 in. (0.97-1.09 mm)
	Torque	12-18 ft-lbs (16-24 Nm)
Engine idle speed	Idle speed	950-1050 RPM
Front fork oil	Type	HYDRAULIC FORK OIL (TYPE E) Part No. 99884-80 (16 oz.)
Battery	Lubricant	ELECTRICAL CONTACT LUBRICANT Part No. 99861-02 (1 oz.)
	Battery terminal torque	60-96 in-lbs (6.8-10.9 Nm)

NOTES

SUBJECT	PAGE NO.
2.1 Specifications	2-1
2.2 Torque Values	2-2
2.3 Vehicle Identification Number (V.I.N.)	2-7
2.4 Front Wheel: FXST/FXSTB/FLSTC/FLSTF/FLSTN	2-9
2.5 Front Wheel: FXSTD	2-12
2.6 Front Wheel: FLSTSC	2-14
2.7 Front Wheel: FXSTS	2-17
2.8 Rear Wheel	2-20
2.9 Sealed Wheel Bearings	2-23
2.10 Wheel Lacing: 16 In. Rim	2-25
2.11 Wheel Lacing: 21 In. Rim	2-28
2.12 Truing Laced Wheel	2-31
2.13 Disc Rim Runout	2-34
2.14 Tires	2-35
2.15 Vehicle Alignment	2-39
2.16 Front Brake Master Cylinder	2-40
2.17 Rear Brake Master Cylinder/Reservoir	2-44
2.18 Front Brake Caliper: All But FLSTSC/FXSTS	2-50
2.19 Front Brake Caliper: FLSTSC	2-55
2.20 Front Brake Caliper: FXSTS	2-58
2.21 Rear Brake Caliper	2-63
2.22 Front Forks: All But FLSTSC/FXSTS	2-67
2.23 Springer Fork: FLSTSC/FXSTS	2-72
2.24 Steering Head	2-82
2.25 Rear Fork	2-86
2.26 Rear Shock Absorbers	2-88
2.27 Throttle Control	2-89
2.28 Clutch Hand Control	2-91
2.29 Front Fender: All But FLSTSC/FXSTS	2-92
2.30 Front Fender: FLSTSC	2-94
2.31 Front Fender: FXSTS	2-96
2.32 Rear Fender: All But FXSTD/FLSTSC/FLSTN	2-98
2.33 Rear Fender: FXSTD	2-102
2.34 Rear Fender: FLSTSC	2-104
2.35 Rear Fender: FLSTN	2-106
2.36 Belt Guard/Debris Deflector	2-109
2.37 Jiffy Stand	2-110
2.38 Fork Lock	2-112
2.39 Seat/Strap Retention Nut	2-113
2.40 Seat: FXST/FXSTB/FXSTS	2-114
2.41 Seat: FLSTF/FLSTC	2-115
2.42 Seat: FXSTD	2-116
2.43 Seat: FLSTSC/FLSTN	2-117
2.44 Luggage Rack: FLSTN	2-118
2.45 Saddlebags: FLSTC	2-119
2.46 Windshield: FLSTC	2-120

SPECIFICATIONS

MODEL	FUEL TANK TOTAL		FUEL TANK RESERVE		OIL TANK W/FILTER		TRANSMISSION (APPROX.)		PRIMARY CHAINCASE	
	gal.	liter	gal.	liter	qt.	liter	oz.	liter	oz.	liter
FLSTC	5.0	18.92	0.5	1.89	3.5	3.31	24	0.71	26	0.77
FLSTF										
FLSTSC										
FLSTN										
FXST										
FXSTB										
FXSTS										
FXSTD	4.9	18.55	0.5	1.89	3.5	3.31	24	0.71	26	0.77

MODEL	WHEEL BASE		OVERALL LENGTH		OVERALL WIDTH		ROAD CLEARANCE		OVERALL HEIGHT		SADDLE HEIGHT	
	in.	mm	in.	mm	in.	mm	in.	mm	in.	mm	in.	mm
FLSTC	64.5	1638.3	94.5	2400.3	37.5	952.5	5.1	129.5	57.8	1468.1	25.5	647.7
FLSTF	64.5	1638.3	94.3	2395.2	40.2	1021.1	5.1	129.5	44.5	1130.3	25.4	645.2
FLSTSC	64.5	1638.3	94.5	2400.3	32.7	830.6	4.9	124.5	43.6	1106.7	25.9	657.8
FLSTN	64.5	1638.3	94.7	2405.4	38.4	975.4	4.8	121.9	43.5	1104.9	24.5	622.3
FXST	66.9	1699.3	95.0	2413.0	37.9	961.9	5.6	142.2	46.4	1178.0	26.1	662.9
FXSTB	66.9	1699.3	95.0	2413.0	30.9	784.9	5.6	142.2	44.9	1140.0	25.2	640.1
FXSTS	65.4	1661.2	93.5	2374.9	32.7	830.6	5.4	137.2	46.4	1178.6	25.2	640.1
FXSTD	66.6	1691.6	95.4	2423.2	35.9	911.9	5.6	142.2	46.4	1178.6	26.0	660.4

MODEL	DRY WEIGHT		GVWR		GAWR FRONT		GAWR REAR	
	lb.	kg	lb.	kg	lb.	kg	lb.	kg
FLSTC	696	316	1160	526.1	430	195	730	331.1
FLSTF	666	302	1160	526.1	430	195	730	331.1
FLSTSC	731	332	1160	526.1	430	195	730	331.1
FLSTN	676	307	1160	526.1	430	195	730	331.1
FXST	629	286	1125	510.3	415	188.2	710	322.1
FXSTB	630	286	1125	510.3	415	188.2	710	332.1
FXSTS	653	296	1125	510.3	415	188.2	710	322.1
FXSTD	645	293	1125	510.3	415	188.2	710	322.1

NOTE

Gross vehicle weight rating (GVWR) (maximum allowable loaded vehicle weight) and corresponding gross axle weight rating (GAWR) are given on a label located on the frame steering head.

NOTE

See [1.9 TIRES AND WHEELS](#) for important information regarding tire data and tire inflations

TORQUE VALUES

ITEM	TORQUE		NOTES
Belt sprocket screws	55-60 ft-lbs	74.6-81.3 Nm	cast wheels, page 2-22
Brake caliper bleeder valve	80-100 in-lbs	9.0-11.3 Nm	all but FLSTS/FXSTS, front and rear, page 2-52
Brake caliper bleeder valve	80-100 in-lbs	9.0-11.3 Nm	front and rear, page 2-65
Brake caliper bridge bolts	28-38 ft-lbs	38.0-51.5 Nm	all but FLSTS/FXSTS front, page 2-65
Brake caliper bridge bolts	28-38 ft-lbs	38.0-51.5 Nm	all but FLSTS/FXSTS, front and rear, page 2-52
Brake disc screws, front	16-24 ft-lbs	21.7-32.5 Nm	all but FLSTS/FXSTS, page 2-11
Brake disc screws, front	16-24 ft-lbs	21.7-32.5 Nm	FLSTS, page 2-14
Brake disc screws, front	16-24 ft-lbs	21.7-32.5 Nm	FXSTS, page 2-17
Brake disc screws, front	16-24 ft-lbs	21.7-32.5 Nm	page 2-11, page 2-13
Brake disc screws, rear	30-45 ft-lbs	40.7-61.0 Nm	LOCTITE THREADLOCKER 243 (blue), page 2-22
Brake pad pins	180-200 in-lbs	20.3-22.6 Nm	all but FLSTS/FXSTS front, 12 pt/0.25 in., page 2-53, page 2-66
Brake reaction link acorn lock-nuts	35-40 ft-lbs	47.5-54.2 Nm	FLSTSC, discard upon removal, page 2-57
Brake reaction link locknut, rigid fork	14-18 ft-lbs	13.6-27.1 Nm	FXSTS, page 2-59
Brake reaction link nut	10-20 ft-lbs	13.6-27.1 Nm	FXSTS, page 2-59
Fender mounting bracket lock-nut	21-27 ft-lbs	28.5-36.6 Nm	FLSTN, page 2-108
Fender pivot shafts	10-20 ft-lbs	13.6-27.1 Nm	FXSTS, LOCTITE THREADLOCKER 262, page 2-97
Fender shoulder screws	10-20 ft-lbs	13.6-27.1 Nm	FXSTS, page 2-97
Fender support hardware	21-27 ft-lbs	28.5-36.6 Nm	all but FXSTD/FLSTS, page 2-101
Fender support hardware	21-27 ft-lbs	28.5-36.6 Nm	FLSTN, page 2-108
Fender support hardware	21-27 ft-lbs	28.5-36.6 Nm	FLSTS, page 2-105
Fender support screws	12-15 ft-lbs	16.3-20.3 Nm	FXSTD, inside of fender, page 2-103
Fender support screws	14-16 ft-lbs	19.0-21.7 Nm	FXSTD, LOCTITE THREADLOCKER 243 (blue), near oil tank, page 2-103
Floorboard/footpeg bracket screws, left side	25-30 ft-lbs	33.9-40.7 Nm	LOCTITE THREADLOCKER 243 (blue), page 2-111
Fork leg bracket screws	35-40 ft-lbs	47.5-54.2 Nm	FLSTS, page 2-57
Fork rocker bearing retainer jam nut	95-105 ft-lbs	128.8-142.4 Nm	FLSTS/FXSTS, page 2-80
Fork rocker bearing retainer	25-35 in-lbs	2.8-4.0 Nm	FLSTS/FXSTS, LOCTITE ANTI-SEIZE, page 2-80
Fork rocker nut	45-50 ft-lbs	61-68 Nm	FLSTS/FXSTS, LOCTITE THREADLOCKER 243 (blue), page 2-80
Fork stem acorn nut	30-35 in-lbs	3.4-4.0 Nm	FLSTS/FXSTS, page 2-75
Fork stem bracket pinch bolt	30-35 ft-lbs	40.7-47.5 Nm	all but FXSTD, page 2-71
Fork stem bracket pinch bolt	35-40 ft-lbs	47.5-54.2 Nm	FXSTD, LOCTITE ANTI-SEIZE, page 2-71
Fork stem nut	35-45 ft-lbs	47.5-61.0 Nm	FXSTD/FXST/FXSTB, page 2-85
Fork stem upper bracket pinch bolt	25-30 ft-lbs	33.9-40.7 Nm	FLSTC/FLSTF, page 2-85

ITEM	TORQUE		NOTES
Fork tube caps	40-60 ft-lbs	54.2-81.3 Nm	all but FLSTS/FXSTS, page 2-71
Front axle nut	50-55 ft-lbs	61.0-74.6 Nm	FXST, FXSTB, FLSTC, FLSTF, FXSTN page 2-11
Front axle nut	50-55 ft-lbs	61.0-74.6 Nm	FXSTD, page 2-13
Front axle nut	60-65 ft-lbs	81.3-88.1 Nm	FLSTS, page 2-16
Front axle nut	60-65 ft-lbs	81.3-88.1 Nm	FXSTS, discard upon removal, page 2-19
Front axle slider cap nuts	11-15 ft-lbs	14.9-20.3 Nm	FXST, FXSTB, FLSTC, FLSTF, FXSTN page 2-11
Front axle slider cap screws	11-15 ft-lbs	14.9-20.3 Nm	FXSTD, tighten rear screw last, page 2-13
Front brake caliper lower mounting bolt	25-30 ft-lbs	33.9-40.7 Nm	FLSTSC, page 2-56
Front brake caliper lower mounting bolt	25-30 ft-lbs	33.9-40.7 Nm	FXSTS, page 2-59
Front brake caliper lower mounting bolt	28-38 ft-lbs	38.0-51.5 Nm	all but FLSTS/FXSTS, short bolt, 12 pt/10 mm, page 2-11, page 2-13, page 2-53
Front brake caliper top mounting bolt	28-38 ft-lbs	38.0-51.5 Nm	all but FLSTS/FXSTS, long bolt, 12 pt/10 mm, page 2-11, page 2-13, page 2-53
Front brake hose bracket bolt	96-120 in-lbs	10.8-13.6 Nm	FLSTC/FLSTF, page 2-85
Front brake hose bracket bolt	96-120 in-lbs	10.8-13.6 Nm	FXSTD/FXST/FXSTB, page 2-85
Front brake reservoir cover screws	6-8 in-lbs	0.7-0.9 Nm	page 2-43, page 2-45, page 2-54, page 2-56, page 2-60
Front caliper banjo bolt	17-22 ft-lbs	23.0-29.8 Nm	FLSTS/FXSTS, page 2-56, page 2-59
Front caliper bleeder valve	80-100 in-lbs	9.0-11.3 Nm	FLSTSC, page 2-56
Front caliper bleeder valve	80-100 in-lbs	9.0-11.3 Nm	FXSTS, page 2-59
Front caliper retaining pad screw	40-50 in-lbs	4.5-5.6 Nm	FLSTS/FXSTS, page 2-62
Front caliper upper mounting bolt	25-30 ft-lbs	33.9-40.7 Nm	FLSTSC, page 2-56
Front caliper upper mounting bolt	25-30 ft-lbs	33.9-40.7 Nm	FXSTS, page 2-59
Front fender acorn nuts	15-21 ft-lbs	20.3-28.5 Nm	FXST/FXSTB, page 2-92
Front fender nut	18-22 ft-lbs	24.4-29.8 Nm	FLSTS, page 2-95
Front fender nuts	15-21 ft-lbs	20.3-28.5 Nm	FLSTC, page 2-92
Front fender nuts	15-21 ft-lbs	20.3-28.5 Nm	FLSTF, page 2-93
Front fender screw locknut	10-20 ft-lbs	13.6-27.1 Nm	FXSTS, page 2-97
Front fender screws	15-21 ft-lbs	20.3-28.5 Nm	FXSTD, page 2-93
Front fender screws	20-25 ft-lbs	27.1-33.9 Nm	FXSTS, page 2-97
Front luggage rack fastener	96-120 in-lbs	10.8-13.6 Nm	FLSTN, page 2-118
Front master cylinder banjo bolt	17-22 ft-lbs	23.0-29.8 Nm	page 2-43
Front shock acorn nuts	45-50 ft-lbs	61.0-67.8 Nm	FLSTS/FXSTS, LOCTITE THREADLOCKER 243 (blue), page 2-74
Handlebar riser locknuts	25-35 ft-lbs	33.9-47.5 Nm	FLSTS/FXSTS, page 2-72
Handlebar riser screws	144-180 in-lbs	16.3-20.3 Nm	FLSTS/FXSTS, page 2-72
Jiffy stand bolt	144-180 in-lbs	16.3-20.3 Nm	page 2-110
License plate bracket screws	144-180 in-lbs	16.3-20.3 Nm	FXSTD, page 2-103
Master cylinder clamp screw	70-80 in-lbs	7.9-9.0 Nm	T27 TORX, page 2-42
Pivot shaft nut	90-110 ft-lbs	122-149.1 Nm	page 2-87

ITEM	TORQUE		NOTES
Rear axle nut	60-65 ft-lbs	81.3-88.1 Nm	page 2-22
Rear luggage rack fastener	12-14 ft-lbs	16.3-19.0 Nm	FLSTN, page 2-118
Rear master cylinder banjo bolt	17-22 ft-lbs	23.0-29.8 Nm	page 2-44
Rear master cylinder nut	50 ft-lbs	67.8 Nm	page 2-44
Rear shock bolt	115-130 ft-lbs	155.9-176.2 Nm	LOCTITE THREADLOCKER 243 (blue), page 2-88
Rear shock locknut	32-39 ft-lbs	43.4-52.9 Nm	page 2-88
Rigid fork leg studs	60-65 ft-lbs	81.3-88.1 Nm	FLSTS/FXSTS, 3 step process, page 2-75
Rocker pivot stud nut	45-50 ft-lbs	61.0-67.8 Nm	FLSTS/FXSTS, page 2-78
Saddlebag acorn nut	120-144 in-lbs	13.6-16.3 Nm	FLSTC, page 2-119
Saddlebag mounting flange nut	120-144 in-lbs	13.6-16.3 Nm	FLSTC, inside saddlebag, page 2-119
Saddlebag stud nut	21-27 ft-lbs	28.5-36.6 Nm	FLSTC, page 2-119
Sissy bar fasteners	35-60 in-lbs	4.0-6.8 Nm	page 2-115
Spoke nipples: chrome aluminum profile laced rim	40-50 in-lbs	4.5-5.6 Nm	16 in., page 2-27, page 2-30
Spoke nipples: steel laced rim	40-50 in-lbs	4.5-5.6 Nm	16 in., page 2-27, page 2-30
Spring bridge acorn nuts	30-35 ft-lbs	40.7-47.5 Nm	FLSTS/FXSTS, page 2-79
Spring rod acorn nut	20-25 ft-lbs	27.1-33.9 Nm	FLSTS/FXSTS, page 2-78
Throttle housing screws	35-45 in-lbs	4.0-5.1 Nm	page 2-89
Upper triple clamp pinch bolt	25-30 ft-lbs	33.9-40.7 Nm	FLSTS/FXSTS, page 2-75
Valve stem nut	12-15 in-lbs	1.4-1.7 Nm	tubeless tire, page 2-36
Valve stem nut	25-35 in-lbs	2.8-4.0 Nm	tube tires, page 2-36

TIRES

WARNING

Match tires, tubes, air valves and caps to the correct wheel rim. Contact a Harley-Davidson dealer. Mismatching can result in damage to the tire bead, allow tire slippage on the rim or cause tire failure, which could result in death or serious injury. (00023a)

Tire sizes are molded on the sidewall. Refer to the TIRE FITMENT TABLES below. Rim size and contour are cast or stamped into the exterior surface of the rim.

Example: T21 x 2.15 TLA DOT. “T” indicates that the rim conforms to Tire and Rim Association standards. The “21” is the normal diameter of the rim in inches, measured at the bead seat diameter. The “2.15” is the width of the bead seat measured in inches. “TLA” designates the rim contour. “DOT” means that the rim meets Department of Transportation Federal Motor Vehicle Safety Standards.

Table 2-1. Fitment – Tubeless Cast Wheels

WHEEL SIZE & POSITION	RIM SIZE & CONTOUR	RIM VALVE HOLE DIA.	TIRE SIZE
			DUNLOP D402
16 in. – Front	T16 x 3.00 D	0.35 in.	MT90B16 72H
			DUNLOP D401
16 in. – Rear	T16 x 3.00 D	0.35 in	150/80B16 71H
			DUNLOP K591
17 in. - Rear	T17 x 4.5 MT	0.35 in	160/70B17 73V

Table 2-2. Tire Fitment – Tube Type Laced Wheels

STEEL LACED RIM			
WHEEL SIZE & POSITION	RIM SIZE & CONTOUR	TUBE SIZE	TIRE SIZE
		Side Valve Tube	DUNLOP D402
21 in. - Front	T21x 2.15 TLA	MH90x21	MH90 - 21 54H
16 in. – Front	T16 x 3.00 D	MT90-16	MT90B16 72H
16 in. – Rear (FLSTN)	T16 x 3.00 D	MT90-16/MU85-16	MU85B16 77H
			DUNLOP D401
16 in. – Rear (all but FLSTN)	T16 x 3.00 D	MT90-16	150/80B16 71H
CHROME ALUMINUM PROFILE LACED RIM			
		Center Valve Tube	DUNLOP D402
21 in. - Front	T21x 2.15 MT	MH90x21	MH90 - 21 54H
16 in. – Front	T16 x 3.0 MT	MT90-16	MT90B16 72H
16 in. – Rear (FLSTN)	T16 x 3.0 MT	MT90-16/MU85-16	MU85B16 77H
			DUNLOP D401
16 in. – Rear (all but FLSTN)	T16 x 3.0 MT	MT90-16	150/80B16 71H

Table 2-3. Tire Pressure – All Models

2005 VEHICLES DUNLOP HARLEY-DAVIDSON TIRES ONLY	TIRE PRESSURE (Cold)			
	Front		Rear	
FLSTC/F/N/SC/I	PSI	kPa	PSI	kPa
Solo rider	36	248	36	248
Rider & one passenger	36	248	40	276
FXST/B/D/S/I	PSI	kPa	PSI	kPa
Solo rider	30	207	36	248
Rider & one passenger	30	207	40	276

GENERAL

See [Figure 2-1](#). The full 17 digit serial, or Vehicle Identification Number (V.I.N.) is stamped on the right side of the steering head and on a label located on the right side down tube.

An abbreviated V.I.N. is stamped on the left side crankcase at the base of the cylinders.

Sample V.I.N. as it appears on the steering head—**1HD1BJY135K110000**

Sample abbreviated V.I.N. as it appears on the left crankcase – **BJY5110000**

NOTE

See [Figure 2-2](#). Always give the complete 17 digit V.I.N. when ordering parts or making inquiries about your motorcycle.

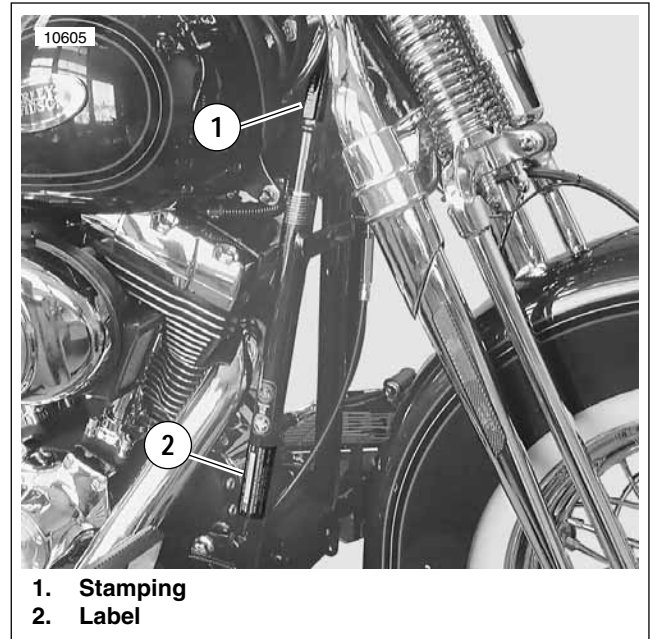

Figure 2-1. V.I.N. Location

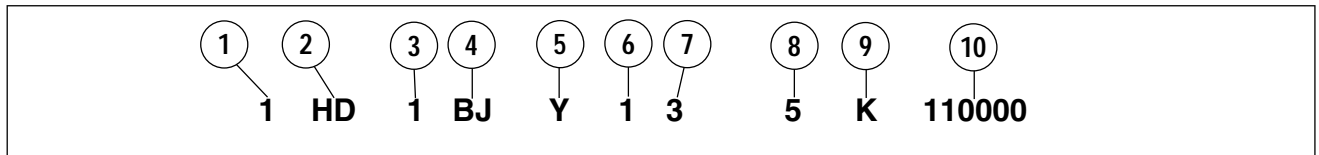

Figure 2-2. Softail Vehicle Identification Number (typical)

Table 2-4. Harley-Davidson 2005 Softail Model V.I.N. Description

ITEM	DESCRIPTION	POSSIBLE VALUES
1	Market destination	1=Domestic 5=International
2	Manufacturer	HD=Harley-Davidson
3	Motorcycle type	1=Heavyweight motorcycle
4	Model	see model V.I.N. table
5	Engine type	Y=Carbureted B=Fuel injected
6	Introduction date	1=Regular 2=Mid-year 3=California
7	VIN check digit	Can be 0-9 or X
8	Model year	5=2005
9	Assembly plant	Y=York, PA.
10	Sequential number (last 6 digits)	varies

Table 2-5. 2005 Softail Model V.I.N. Codes

CODE	MODEL NAME	CODE	MODEL NAME
BH	FXST	BV	FXSTI
BJ	FLSTC	BW	FLSTCI
BL	FXSTS	BZ	FXSTSI
BM	FLSTF	BX	FLSTFI
BS	FXSTD	JB	FXSTDI
BT	FXSTB	JA	FXSTBI
BN	FLSTN	JD	FLSTNI
BR	FLSTSC	BY	FLSTSCI

REMOVAL

1. Block motorcycle underneath frame so front wheel is raised off the ground.
2. Inspect wheel bearing end play and service bearings if necessary. See 2.9 SEALED WHEEL BEARINGS.
3. See Figure 2-3. Remove brake caliper. Support caliper using a rubber bungee cord. Be careful not to scratch the fender paint.

NOTE

Do not operate front brake lever with the front wheel removed or the caliper piston may be forced out of piston bore. Reseating the piston requires disassembly of the caliper.

4. Remove axle nut, lockwasher and washer (3).
5. Label wheel spacers for location (left or right) and orientation (fork side or wheel side).
6. See Figure 2-4. Loosen the slider cap nuts (2) and pull the axle (1) free.
7. Remove wheel from forks.

NOTE

On FLSTC models, the hub cap will come off with the wheel.

DISASSEMBLY

NOTE

See 2.14 TIRES to service tire or valve stem assembly.

Disc Wheel

1. See Figure 2-5. Remove spacers (2, 8) from left and right sides.
2. If necessary, remove brake disc (9) and/or hub plate (6). Label components so they may be installed in their original locations.
 - a. On left side of wheel, remove five screws (5) to detach left brake disc (9).
 - b. On right side of wheel, remove five screws (5) to remove hub plate (6).

Laced Wheel

1. See Figure 2-6. On all models with laced wheels except FLSTC and FXSTD, remove spacers (3, 7) from left and right sides. All FLSTC models use a spacer within the hub cap assembly (2) on the right side.
2. If necessary, remove brake disc (8). Label components so they may be installed in their original locations. On left side of wheel, remove five screws (12) to detach left brake disc (8).
3. To disassemble FLSTC hub cap, remove snap ring from hub spacer. Discard snap ring.

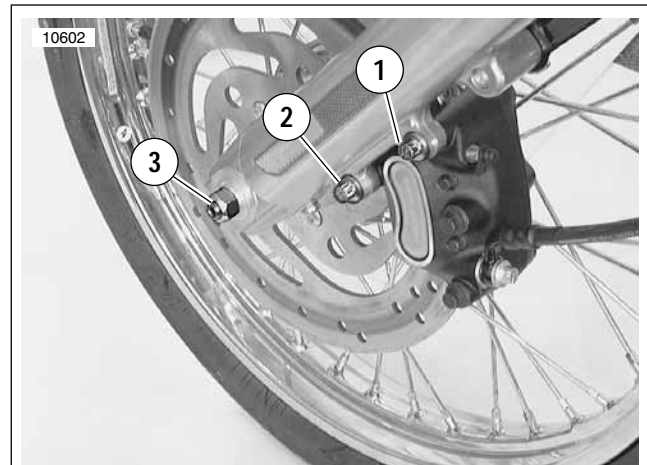

1. Long mounting bolt (12 pt/10 mm)
2. Short mounting bolt (12 pt/10 mm)
3. Axle nut, lockwasher and washer

Figure 2-3. Caliper Mounting Bolts: FXST, FXSTB, FLSTC, FLSTF, FXSTN (Left Side)

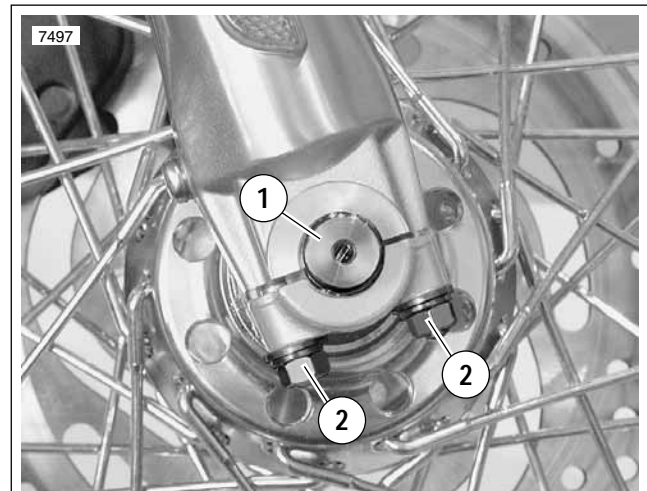

1. Axle
2. Slider cap nuts and washers

Figure 2-4. Front Wheel Mounting FXST, FXSTB, FLSTC, FLSTF, FXSTN (Right Side)

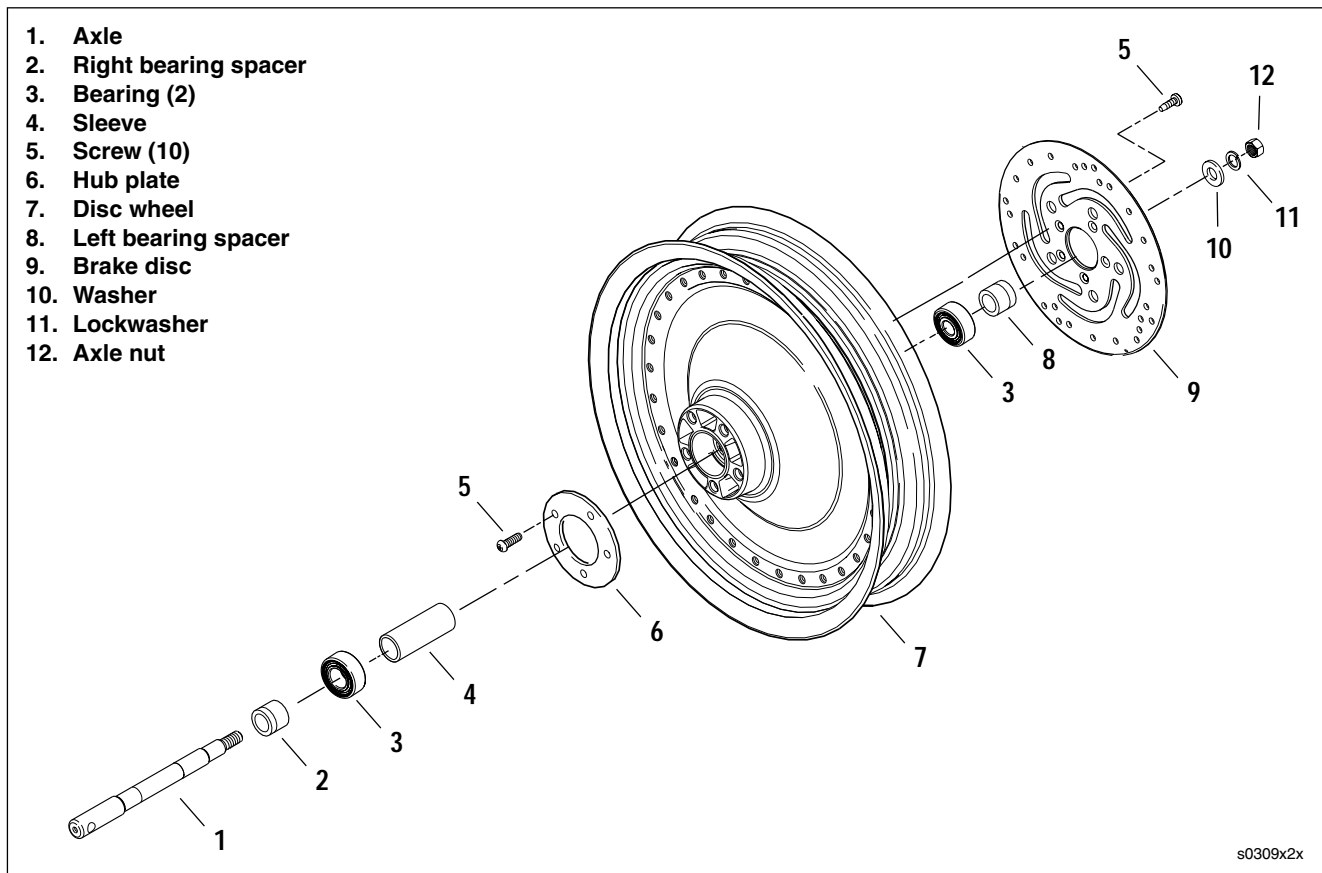

Figure 2-5. Disc Front Wheel: FLSTF

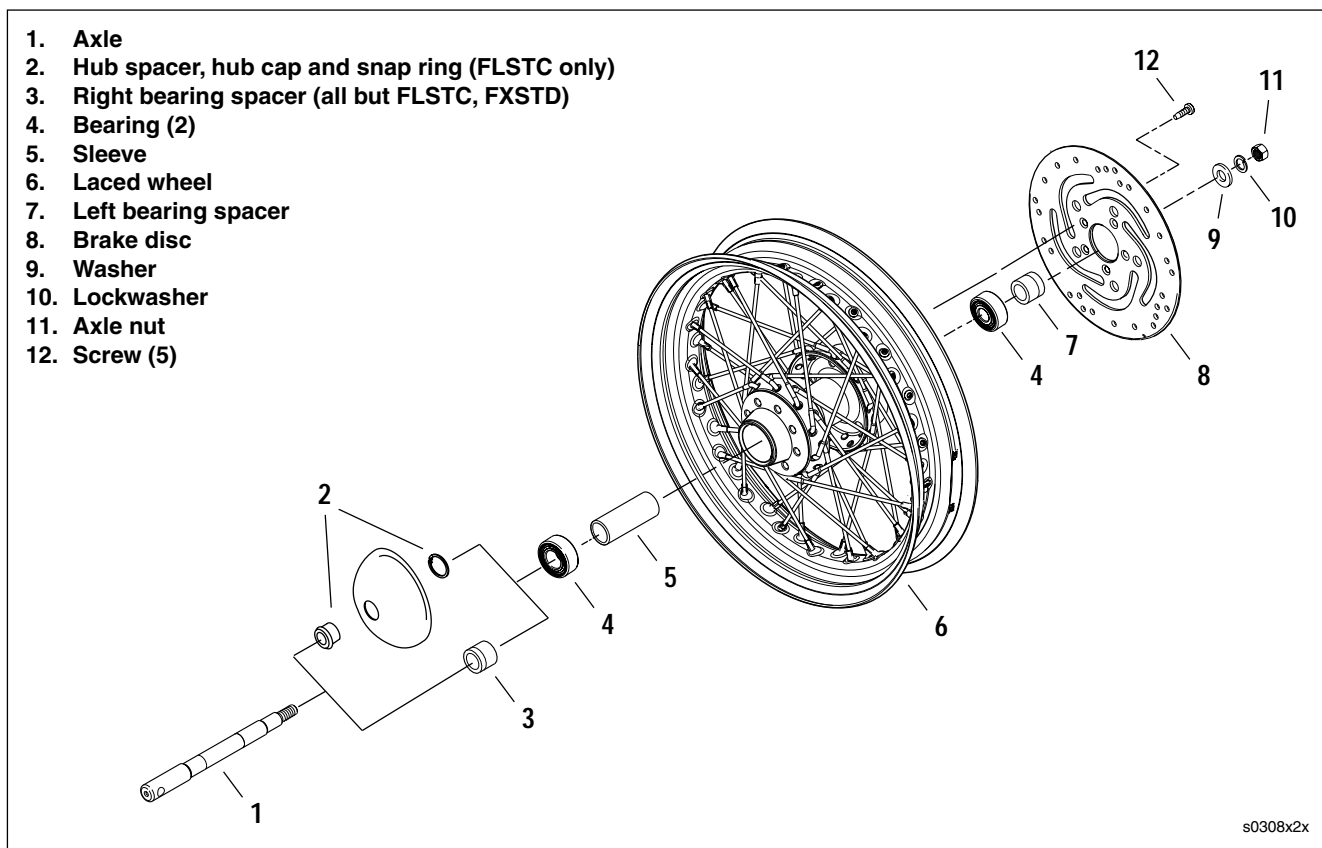

Figure 2-6. Laced Front Wheel: All But FLSTF, FXSTD

CLEANING AND INSPECTION

1. Inspect all parts for damage or excessive wear. If sealed wheel bearings must be serviced, see [2.9 SEALED WHEEL BEARINGS](#).

WARNING

Always replace brake pads in complete sets for correct and safe brake operation. Improper brake operation could result in death or serious injury. (00111a)

2. Inspect brake rotor and pads. See [1.8 BRAKE PADS AND DISCS](#).

ASSEMBLY

Disc Wheel

WARNING

Be sure that brake fluid or other lubricants do not contact brake pads or discs. Such contact can adversely affect braking ability, which could cause loss of control, resulting in death or serious injury. (00290a)

1. See [Figure 2-5](#). If necessary, install brake disc (9) and/or hub plate (6) in their original positions. Verify that brake disc is clean. Tighten fasteners to 16-24 ft-lbs (21.7-32.5 Nm).
 - a. On left side of wheel, install five **new** screws (5) to attach left brake disc (9).
 - b. On right side of wheel, install five **new** screws (5) to attach hub plate (6).
2. Install spacers (2, 8) with largest chamfered end facing away from wheel.
3. Verify that wheel and tire are true. See [2.13 DISC RIM RUNOUT](#).

Laced Wheel

1. If hub and rim were disassembled, see [2.10 WHEEL LACING: 16 IN. RIM](#) or [2.11 WHEEL LACING: 21 IN. RIM](#).
2. On FLSTC models, attach hub cap to spacer with **new** snap ring.

WARNING

Be sure that brake fluid or other lubricants do not contact brake pads or discs. Such contact can adversely affect braking ability, which could cause loss of control, resulting in death or serious injury. (00290a)

3. See [Figure 2-6](#). If necessary, install brake disc in its original position. Verify that brake disc is clean. On left side of wheel, install five **new** screws (12) to attach brake disc (8). Tighten fasteners to 16-24 ft-lbs (21.7-32.5 Nm).
4. Install hub assembly (2) or spacers (3, 7) with largest chamfered end facing away from wheel.
5. Verify that wheel and tire are true. See [2.12 TRUING LACED WHEEL](#).

INSTALLATION

FXST, FXSTB, FLSTC, FLSTF, FLSTN Models

1. Apply a light coat of LOCTITE ANTI-SEIZE LUBRICANT to the axle.
2. Place wheel into front fork and install axle. Verify that axle spacers on right and left side are properly installed.
3. Install the washer, lockwasher and axle nut. Insert screwdriver or steel rod through hole in axle on right side of vehicle. While holding axle stationary, tighten axle nut to 50-55 ft-lbs (67.8-74.6 Nm).
4. See [Figure 2-4](#). Tighten the slider cap nuts to 11-15 ft-lbs (14.9-20.3 Nm).
5. See [Figure 2-3](#). Install the brake caliper to the fork legs.
 - a. Loosely install long mounting bolt (1) (12 pt/10 mm) into top hole on fork leg.
 - b. Install short mounting bolt (2) (12 pt/10 mm) into bottom hole on fork leg. Tighten bottom mounting bolt to 28-38 ft-lbs (38.0-51.5 Nm).
 - c. Final tighten the top mounting bolt to 28-38 ft-lbs (38.0-51.5 Nm).

WARNING

Whenever a wheel is installed and before moving the motorcycle, pump brakes to build brake system pressure. Insufficient pressure can adversely affect brake performance, which could result in death or serious injury. (00284a)

6. Pump brake hand lever to move pistons out until they contact both brake pads. Verify piston location against pads.

REMOVAL

1. Block motorcycle underneath frame so front wheel is raised off the ground.
2. Inspect wheel bearing end play and service bearings if necessary. See [2.9 SEALED WHEEL BEARINGS](#).
3. See [Figure 2-7](#). Remove brake caliper. Support caliper using a rubber bungee cord. Be careful not to scratch the fender paint.

NOTE

Do not operate front brake lever with the front wheel removed or the caliper piston may be forced out of piston bore. Reseating the piston requires disassembly of the caliper.

4. Remove left axle nut, lockwasher and washer (3).
5. Label wheel spacers for location (left or right) and orientation (fork side or wheel side).
6. See [Figure 2-8](#). Loosen the slider cap screws (2) and pull the axle free.
7. Remove wheel from forks.

DISASSEMBLY

NOTE

See [2.14 TIRES](#) to service tire or valve stem assembly.

1. See [Figure 2-9](#). Remove spacers (3, 7) from left and right sides.
2. If necessary, remove brake disc (8). Label components so they may be installed in their original locations. On left side of wheel, remove five screws (11) to detach left brake disc.

CLEANING AND INSPECTION

1. Inspect all parts for damage or excessive wear. If sealed wheel bearings must be serviced, see [2.9 SEALED WHEEL BEARINGS](#).

WARNING

Always replace brake pads in complete sets for correct and safe brake operation. Improper brake operation could result in death or serious injury. (00111a)

2. Inspect brake rotor and pads. See [1.8 BRAKE PADS AND DISCS](#).

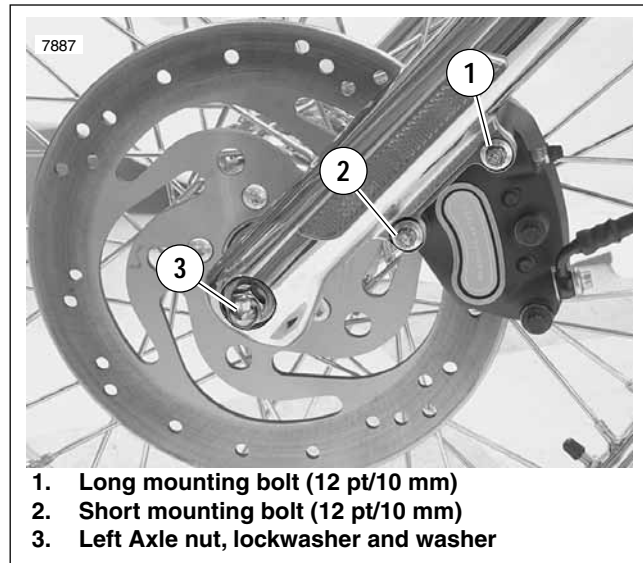

1. Long mounting bolt (12 pt/10 mm)
2. Short mounting bolt (12 pt/10 mm)
3. Left Axle nut, lockwasher and washer

Figure 2-7. Caliper Mounting Bolts: FXSTD (Left Side)

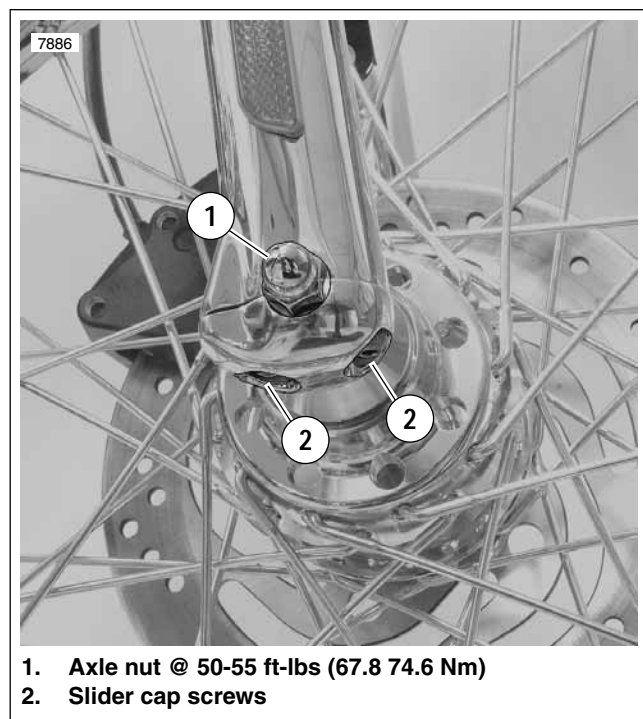

1. Axle nut @ 50-55 ft-lbs (67.8 74.6 Nm)
2. Slider cap screws

Figure 2-8. Front Wheel Mounting FXSTD (Right Side)



Suggest:

For more complete manuals. Please go to the home page.

<https://www.ebooklibonline.com>

If the above button click is invalid. Please download this document first, and then click the above link to download the complete manual.

Thank you so much for reading

ASSEMBLY

1. If hub and rim were disassembled, see [2.11 WHEEL LACING: 21 IN. RIM.](#)

WARNING

Be sure that brake fluid or other lubricants do not contact brake pads or discs. Such contact can adversely affect braking ability, which could cause loss of control, resulting in death or serious injury. (00290a)

2. See [Figure 2-9](#). If necessary, install brake disc (8) in its original position. Verify that brake disc is clean. On left side of wheel, install five **new** screws (11) to attach left brake disc. Tighten fasteners to 16-24 ft-lbs (21.7-32.5 Nm).
3. Install spacers (3, 7) with largest chamfered end facing away from wheel.
4. Verify that wheel and tire are true. See [2.12 TRUING LACED WHEEL.](#)

INSTALLATION

1. Apply a light coat of LOCTITE ANTI-SEIZE LUBRICANT to the axle.
2. Verify that axle spacers on right and left side are properly installed. Place wheel into front fork and install axle.

3. Install the washer, lockwasher and left axle nut. Hold right side axle nut with wrench then tighten left axle nut to 50-55 ft-lbs (67.8-74.6 Nm).
4. See [Figure 2-8](#). Tighten front slider cap screw to 11-15 ft-lbs (14.9-20.3 Nm) and then tighten rear slider cap screw to 11-15 ft-lbs (14.9-20.3 Nm). Using this sequence ensures proper installation.
5. See [Figure 2-7](#). Install the brake caliper to the fork legs.
 - a. Loosely install long mounting bolt (1) (12 pt/10 mm) into top hole on fork leg.
 - b. Install short mounting bolt (2) (12 pt/10 mm) into bottom hole on fork leg. Tighten bottom mounting bolt to 28-38 ft-lbs (38.0-51.5 Nm).
 - c. Final tighten the top mounting bolt to 28-38 ft-lbs (38.0-51.5 Nm).

WARNING

Whenever a wheel is installed and before moving the motorcycle, pump brakes to build brake system pressure. Insufficient pressure can adversely affect brake performance, which could result in death or serious injury. (00284a)

6. Pump brake hand lever to move pistons out until they contact both brake pads. Verify piston location against pads.

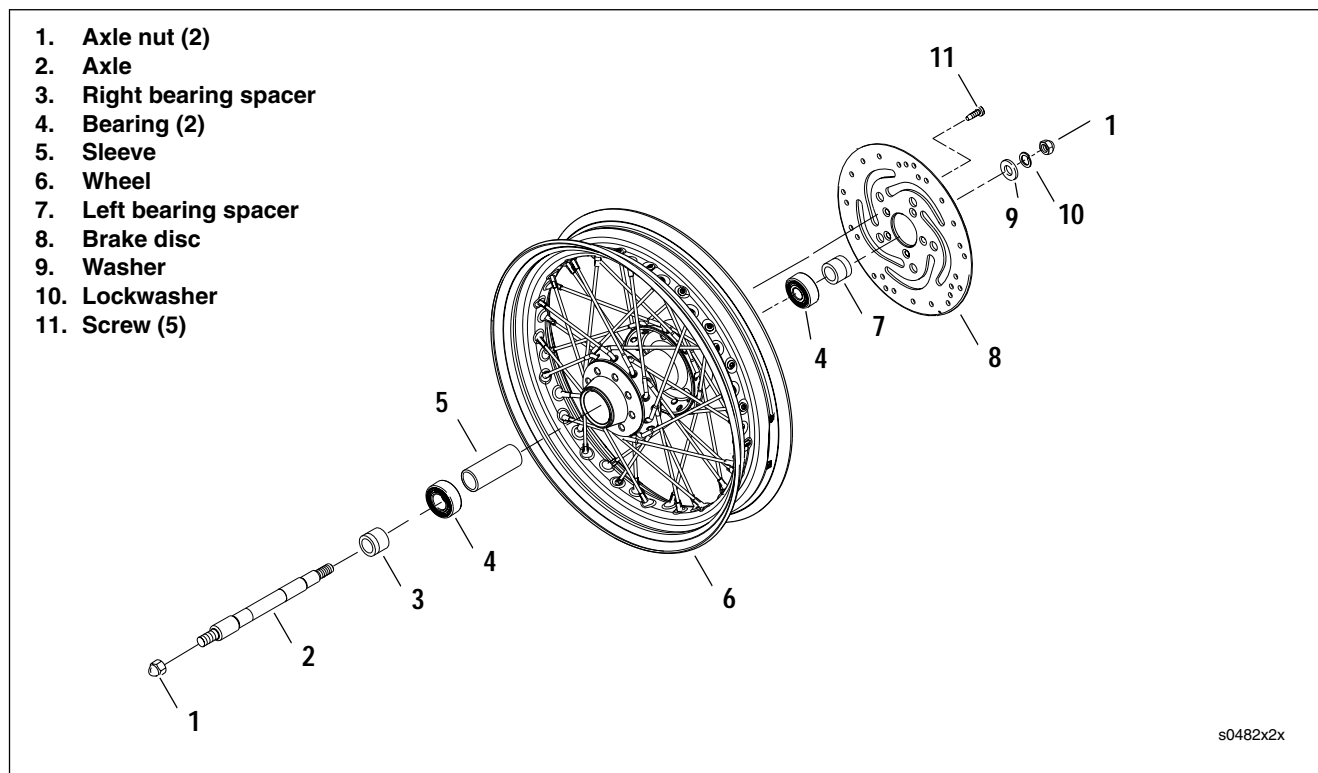

Figure 2-9. Front Wheel FXSTD

REMOVAL

PART NO.	SPECIALTY TOOL
HD-41494	Hub cap remover/installer

1. Block motorcycle underneath frame so front wheel is raised off the ground.
2. Inspect wheel bearing end play and service bearings if necessary. See [2.9 SEALED WHEEL BEARINGS](#).
3. Remove front brake caliper. See [2.19 FRONT BRAKE CALIPER: FLSTSC](#). Support caliper using a rubber bungee cord. Be careful not to scratch the fender paint.

NOTE

Do not operate front brake lever with the front wheel removed or the caliper piston may be forced out of piston bore. Reseating the piston requires disassembly of the caliper.

4. See [Figure 2-10](#). Remove hub caps (1, 25) and hub cap seals (2, 24) using HUB CAP REMOVER/INSTALLER (Part No. HD-41494).
5. Label wheel spacers for location (left or right) and orientation (fork side or wheel side).
6. Remove retaining pin (23) from castle nut (22).
7. Place a towel under hub to catch any loose parts which may fall from hub.
8. Slide axle out of hub and rockers to remove front wheel.

DISASSEMBLY

NOTE

See [2.14 TIRES](#) to service tire or valve stem assembly.

1. See [Figure 2-10](#). Remove spacers (8, 13).
2. If necessary, remove brake disc. Label components so they may be installed in their original locations. On left side of wheel, remove five screws to detach left brake disc.

NOTE

See [2.23 SPRINGER FORK: FLSTSC/FXSTS](#) to service fork rockers.

CLEANING AND INSPECTION

1. Inspect all parts for damage or excessive wear. If sealed wheel bearings must be serviced, see [2.9 SEALED WHEEL BEARINGS](#).

⚠ WARNING

Always replace brake pads in complete sets for correct and safe brake operation. Improper brake operation could result in death or serious injury. (00111a)

2. Inspect brake rotor and pads.
 - a. Minimum brake pad thickness: 0.06 in. (1.6 mm) or less above the backing plate.
 - b. Minimum brake disc thickness is stamped on the side of the disc. Replace disc if badly scored.
 - c. Maximum brake disc lateral runout and warp is 0.008 in. (0.2 mm).

ASSEMBLY

1. If hub and rim were disassembled, see [2.10 WHEEL LACING: 16 IN. RIM](#).

⚠ WARNING

Be sure that brake fluid or other lubricants do not contact brake pads or discs. Such contact can adversely affect braking ability, which could cause loss of control, resulting in death or serious injury. (00290a)

2. If necessary, install brake disc in its original position. Verify that brake disc is clean. On left side of wheel, install five **new** screws to attach brake disc. Tighten fasteners to 16-24 ft-lbs (21.7-32.5 Nm).
3. See [Figure 2-10](#). If bearings were removed, verify that sleeve (10) is installed. Install spacers (8, 13) next to bearings.
4. Verify that wheel and tire are true. See [2.12 TRUING LACED WHEEL](#).

<https://www.ebooklibonline.com>

Hello dear friend!

Thank you very much for reading.

Enter the link into your browser.

The full manual is available for immediate download.

<https://www.ebooklibonline.com>