



TOURING MODELS
2004 HARLEY-DAVIDSON® SERVICE MANUAL

P/N 99483-04

2004 FLT MODELS

SERVICE MANUAL

Part Number 99483-04

Section 1: Maintenance
Section 2: Chassis
Section 3: Engine
Section 4: Fuel System
Section 5: Starter
Section 6: Drive
Section 7: Transmission
Section 8: Electrical
Section 9: Fuel Injection
Appendix

POLICE SERVICE SUPPLEMENT

Part Number 99483-04SP

Section 1: Maintenance
Section 2: Chassis
Section 3: Engine (No content)
Section 4: Fuel System (No content)
Section 5: Starter (No content)
Section 6: Drive (No content)
Section 7: Transmission (No content)
Section 8: Electrical
Section 9: Fuel Injection (No content)

ELECTRICAL DIAGNOSTICS

Part Number 99497-04

Section 1: Starting & Charging
Section 2: Instruments
Section 3: TSM & TSSM
Section 4: Engine Management
Section 5: Engine Management (EFI)
Section 6: Sound System
Section 7: Cruise Control
Section 8: Wiring

FLHTCSE SERVICE SUPPLEMENT

Part Number 99500-04

Section 1: Maintenance
Section 2: Chassis
Section 3: Engine
Section 4: Fuel System (No content)
Section 5: Starter
Section 6: Drive
Section 7: Transmission
Section 8: Electrical
Section 9: Fuel Injection (No content)

[Table Of Contents](#)

SUBJECT	PAGE NO.
1.1 Troubleshooting	1-1
1.2 Shop Practices	1-5
1.3 Tool Safety	1-8
1.4 Scheduled Maintenance Table	1-11
1.5 Scheduled Maintenance Procedures	1-15

<https://www.ebooklibonline.com>

Hello dear friend!

Thank you very much for reading.

Enter the link into your browser.

The full manual is available for immediate download.

<https://www.ebooklibonline.com>

GENERAL

The following check list of possible operating troubles and their probable causes will be helpful in keeping your motorcycle in good operating condition. More than one of these conditions may be causing the trouble and all should be carefully checked.

WARNING

The troubleshooting section of this manual is intended solely as a guide to diagnosing problems. Carefully read the appropriate sections of this manual before performing any work. Improper repair and/or maintenance could result in death or serious injury.

ENGINE

Starter Motor Does Not Operate or Does Not Turn Engine Over

1. Ignition/Light Key Switch not in IGNITION position.
2. Engine Stop switch in the OFF position.
3. Discharged battery, loose or corroded connections (solenoid chatters).
4. TSM/TSSM BAS tripped and Ignition/Light Key Switch not cycled to OFF and then back to IGNITION.
5. Starter control circuit, relay or solenoid faulty.
6. Electric starter shaft pinion gear not engaging or over-running clutch slipping.

Engine Turns Over But Does Not Start

1. Fuel tank empty.
2. Fuel supply valve turned to OFF.
3. Fouled spark plugs.
4. Engine flooded with gasoline as a result of over use of enrichener.
5. Fuel valve or filter clogged.
6. Vacuum hose to automatic fuel supply valve disconnected, leaking or pinched.
7. Discharged battery, loose or broken battery terminal connections.
8. Loose wire connection at coil, battery or plug between ignition sensor and module.
9. Spark plug cables in bad condition and shorting, cable connections loose, or cables connected to wrong cylinders.

10. Ignition timing incorrect due to faulty ignition coil, ignition module or sensors (MAP, CKP and/or TSM/TSSM).
11. Engine lubricant too heavy (winter operation).

NOTE

Always disengage clutch for cold weather starts.

12. Sticking or damaged valve or push rod wrong length.
13. Primary cam sprocket spline sheared or missing spacer.

Starts Hard

1. Spark plugs in bad condition, have improper gap or are partially fouled.
2. Spark plug cables in bad condition.
3. Battery nearly discharged.
4. Loose wire connection at one of the battery terminals, ignition coil or plug between ignition sensor and module.
5. Carburetor controls not adjusted correctly.
6. Water or dirt in fuel system and carburetor.
7. Intake air leak.
8. Fuel tank vent hose and vapor valve plugged, or carburetor fuel line closed off and restricting fuel flow.
9. Enrichener valve inoperative.
10. Engine lubricant too heavy (winter operation).

NOTE

Always disengage clutch for cold weather starts.

11. Ignition not functioning properly (possible sensor failure).
12. Faulty ignition coil.
13. Valves sticking.

Starts But Runs Irregularly or Misses

1. Spark plugs in bad condition or partially fouled.
2. Spark plug cables in bad condition and leaking.
3. Spark plug gap too close or too wide.
4. Faulty ignition coil, module and/or sensor.
5. Battery nearly discharged.
6. Damaged wire or loose connection at battery terminals, ignition coil, or plug between ignition sensor and module.
7. Intermittent short circuit due to damaged wire insulation.
8. Water or dirt in fuel system, carburetor or filter.
9. Fuel tank vent system plugged or carburetor vent line closed off.
10. Carburetor controls misadjusted.
11. Damaged carburetor.

12. Loose or dirty ignition module connector at crankcase.
13. Faulty MAP and/or CKP Sensor.
14. Incorrect valve timing.
15. Weak or broken valve springs.
16. Damaged intake or exhaust valve.

A Spark Plug Fouls Repeatedly

1. Fuel mixture too rich or enricher left out too long.
2. Incorrect spark plug for the kind of service.
3. Piston rings badly worn or broken.
4. Valve guides or seals badly worn.

Pre-Ignition or Detonation (Knocks or Pings)

1. Fuel octane rating too low.
2. Faulty spark plugs.
3. Incorrect spark plug for the kind of service.
4. Excessive carbon deposit on piston head or in combustion chamber.
5. Ignition timing advanced due to faulty sensor inputs (MAP, CKP).

Overheating

1. Insufficient oil supply or oil not circulating.
2. Insufficient air flow over engine.
3. Heavy carbon deposit.
4. Ignition timing retarded due to faulty MAP and/or CKP Sensor.
5. Leaking valve.

Valve Train Noise

1. Low oil pressure caused by oil feed pump not functioning properly or oil passages obstructed.
2. Faulty hydraulic lifters.
3. Bent push rod.
4. Incorrect push rod length.
5. Rocker arm binding on shaft.
6. Valve sticking in guide.
7. Chain tensioner spring or shoe worn.

Excessive Vibration

1. Wheels and/or tires worn or damaged.
2. Engine/transmission/motorcycle not aligned properly.
3. Primary chain badly worn or links tight as a result of insufficient lubrication or misalignment.

4. Engine to transmission mounting bolts loose.
5. Upper engine mounting bracket loose.
6. Ignition timing incorrect/poorly tuned engine.
7. Internal engine problem.
8. Broken frame.
9. Stabilizer links worn or loose.
10. Rubber mounts loose or worn.
11. Rear fork pivot shaft nuts loose.
12. Front engine mounting bolts loose.

Check Engine Lamp Illuminates During Operation

1. Fault detected. Check for trouble codes.

LUBRICATION SYSTEM

Oil Does Not Return To Oil Pan

1. Oil pan empty.
2. Oil pump not functioning.
3. Restricted oil lines or fittings.
4. Restricted oil filter.
5. Oil pump misaligned or in poor condition.
6. O-ring damaged or missing from oil pump/crankcase junction (also results in poor engine performance).

Engine Uses Too Much Oil Or Smokes Excessively

1. Oil pan overfilled.
2. Restricted oil return line to pan.
3. Restricted breather operation.
4. Restricted oil filter.
5. Oil pump misaligned or in poor condition.
6. Piston rings badly worn or broken.
7. Valve guides or seals worn.
8. O-ring damaged or missing from oil pump/crankcase junction (also results in poor engine performance).

Engine Leaks Oil From Case, Push Rods, Hoses, Etc.

1. Loose parts.
2. Imperfect seal at gaskets, push rod cover, washers, etc.
3. Restricted oil return line to pan.
4. Restricted breather hose to air cleaner.
5. Restricted oil filter.

6. Oil pan overfilled.
7. Rocker housing gasket (bottom) installed upside down.

Low Oil Pressure

1. Oil pan underfilled.
2. Faulty low oil pressure switch.
3. Oil pump O-ring(s) damaged or missing.
4. Oil pressure relief valve stuck in open position.
5. Ball or clean out plug missing from cam support plate.

High Oil Pressure

1. Oil pan overfilled.
2. Oil pressure relief valve stuck in closed position.

ELECTRICAL SYSTEM

Alternator Does Not Charge

1. Module not grounded.
2. Engine ground wire loose or broken.
3. Faulty regulator-rectifier module.
4. Loose or broken wires in charging circuit.
5. Faulty stator and/or rotor.

Alternator Charge Rate Is Below Normal

1. Weak or damaged battery.
2. Loose connections.
3. Faulty regulator-rectifier module.
4. Faulty stator and/or rotor.

Speedometer Operates Erratically

1. Contaminated speedometer sensor (remove sensor and clean off metal particles).
2. Loose connections.

CARBURETOR

Carburetor Floods

1. Dirt or other foreign matter between valve and its seat.
2. Inlet valve sticking.

3. Inlet valve and/or valve seat worn or damaged.
4. Float misadjusted.
5. Leaky or damaged float.
6. Excessive "pumping" of hand throttle grip.
7. See TROUBLESHOOTING CHART in Section 4.

TRANSMISSION

Transmission Shifts Hard

1. Clutch dragging slightly.
2. Primary chaincase overfilled with lubricant.
3. Corners worn off shifter clutch dogs.
4. Shifter return spring bent or broken.
5. Bent shifter rod.
6. Shifter forks sprung.
7. Transmission lubrication too heavy (winter operation).

Jumps Out Of Gear

1. Shifter rod improperly adjusted.
2. Shifter drum damaged.
3. Shifter engaging parts (inside transmission) badly worn and rounded.
4. Shifter forks bent.
5. Damaged gears.

Clutch Slips

1. Clutch controls improperly adjusted.
2. Insufficient clutch spring tension.
3. Worn friction discs.

Clutch Drags Or Does Not Release

1. Clutch controls improperly adjusted.
2. Lubricant level too high in primary chaincase.
3. Primary chain badly misaligned.
4. Clutch discs warped.
5. Insufficient clutch spring tension.

Clutch Chatters

1. Friction discs or steel discs worn or warped.

BRAKES

Brake Does Not Hold Normally

1. Master cylinder reservoir low on fluid.
2. Brake system contains air bubbles.
3. Master or wheel cylinder piston worn or parts damaged.
4. Brake pads contaminated with grease or oil.
5. Brake pads badly worn- friction material 0.04 inch (1.02 mm) thick or less.
6. Brake disc badly worn or warped.
7. Brake fades due to heat build up – brake pads dragging or excessive braking.
8. Brake drags – insufficient brake pedal free play.

HANDLING

Irregularities

1. Improperly loaded motorcycle. Non-standard equipment on the front end such as heavy radio receivers, extra lighting equipment or luggage tends to cause unstable handling.
2. Incorrect air suspension pressure.
3. Damaged tire(s) or improper front-rear tire combination.
4. Irregular or peaked front tire tread wear.
5. Incorrect tire pressure.
6. Shock absorber not functioning normally.
7. Loose wheel axle nuts. Tighten to recommended tightness.
8. Excessive wheel hub bearing play.
9. Improper vehicle alignment.
10. Steering head bearings improperly adjusted. Correct adjustment and replace pitted or worn bearings and races.
11. Tire and wheel unbalanced.
12. Rims and tires out-of-round or eccentric with hub.
13. Rims and tires out-of-true sideways.
14. Shock absorber improperly adjusted.
15. Worn engine stabilizer links.
16. Damaged rear engine isolation mounts.
17. Swingarm pivot shaft nut improperly tightened or assembled.

REPAIR NOTES

General maintenance practices are given in this section. All special tools and torque values are noted at the point of use and all required parts or materials can be found in the appropriate PARTS CATALOG.

Safety

Safety is always the most important consideration when performing any job. Be sure you have a complete understanding of the task to be performed. Use common sense. Use the proper tools. Don't just do the job – do the job safely.

Removing Parts

Always consider the weight of a part when lifting. Use a hoist whenever necessary. Do not lift heavy parts by hand. A hoist and adjustable lifting beam or sling are needed to remove some parts. The lengths of chains or cables from the hoist to the part should be equal and parallel, and should be positioned directly over the center of the part. Be sure that no obstructions will interfere with the lifting operation. Never leave a part suspended in mid-air.

Always use blocking or proper stands to support the part that has been hoisted. If a part cannot be removed, verify that all bolts and attaching hardware have been removed. Check to see if any parts are in the way of the part being removed.

When removing hoses, wiring or tubes, always tag each part to ensure proper installation.

Cleaning

If you intend to reuse parts, follow good shop practice and thoroughly clean the parts before assembly. Keep all dirt out of parts; the unit will perform better and last longer. Seals, filters and covers are used in this motorcycle to keep out environmental dirt and dust. These items must be kept in good condition to ensure satisfactory operation.

Clean and inspect all parts as they are removed. Be sure all holes and passages are clean and open. After cleaning, cover all parts with clean lint-free cloth, paper or other material. Be sure the part is clean when it is installed.

Always clean around lines or covers before they are removed. Plug, tape or cap holes and openings to keep out dirt, dust and debris.

Always verify cleanliness of blind holes before assembly. Tightening screws with dirt, water or oil in the holes can cause castings to crack or break.

Disassembly and Assembly

Always assemble or disassemble one part at a time. Do not work on two assemblies simultaneously. Be sure to make all necessary adjustments. Recheck your work when finished. Be sure that everything is done.

Operate the motorcycle to perform any final check or adjustments. If all is correct, the motorcycle is ready to go back to the customer.

Checking Torques on Fasteners with Lock Patches

To check the torque on a fastener that has a lock patch:

1. Set the torque wrench for the lowest setting in the specified torque range.
2. Attempt to tighten fastener to set torque. If fastener does not move and lowest setting is satisfied (torque wrench clicks), then the proper torque has been maintained.

REPAIR AND REPLACEMENT PROCEDURES

Hardware and Threaded Parts

Install helical thread inserts when inside threads in castings are stripped, damaged or not capable of withstanding specified torque.

Replace bolts, nuts, studs, washers, spacers and small common hardware if missing or in any way damaged. Clean up or repair minor thread damage with a suitable tap or die.

Replace all damaged or missing lubrication fittings.

Use Teflon tape on pipe fitting threads.

Wiring, Hoses and Lines

Replace hoses, clamps, electrical wiring, electrical switches or fuel lines if they do not meet specifications.

Instruments and Gauges

Replace broken or defective instruments and gauges. Replace dials and glass that are so scratched or discolored that reading is difficult.

Bearings

Anti-friction bearings must be handled in a special way. To keep out dirt and abrasives, cover the bearings as soon as they are removed from the package.

Wash bearings in a non-flammable cleaning solution. Knock out packed lubricant inside by tapping the bearing against a wooden block. Wash bearings again. Cover bearings with clean material after setting them down to dry. Never use compressed air to dry bearings.

Coat bearings with clean oil. Wrap bearings in clean paper.

Be sure that the chamfered side of the bearing always faces the shoulder (when bearings installed against shoulders). Lubricate bearings and all metal contact surfaces before pressing into place. Only apply pressure on the part of the bearing that makes direct contact with the mating part.

Always use the proper tools and fixtures for removing and installing bearings.

Bearings do not usually need to be removed. Only remove bearings if necessary.

Bushings

Do not remove a bushing unless damaged, excessively worn or loose in its bore. Press out bushings that must be replaced.

When pressing or driving bushings, be sure to apply pressure in line with the bushing bore. Use a bearing/bushing driver or a bar with a smooth, flat end. Never use a hammer to drive bushings.

Inspect the bushing and the mated part for oil holes. Be sure all oil holes are properly aligned.

Gaskets

Always discard gaskets after removal. Replace with new gaskets. Never use the same gasket twice (unless instructed otherwise). Be sure that gasket holes match up with holes in the mating part.

If a gasket must be made, be sure to cut holes that match up with the mating part. Serious damage can occur if any flange holes are blocked by the gasket. Use material that is the right type and thickness.

Lip Type Seals

Lip seals are used to seal oil or grease and are usually installed with the sealing lip facing the contained lubricant. Seal orientation, however, may vary under different applications.

Seals should not be removed unless necessary. Only remove seals if required to gain access to other parts or if seal damage or wear dictates replacement.

Leaking oil or grease usually means that a seal is damaged. Replace leaking seals to prevent overheated bearings.

Always discard seals after removal. Do not use the same seal twice.

O-Rings (Preformed Packings)

Always discard O-rings after removal. Replace with new O-rings. To prevent leaks, lubricate the O-rings before installation. Apply the same type of lubricant as that being sealed. Be sure that all gasket, O-ring and seal mating surfaces are thoroughly clean before installation.

Gears

Always check gears for damaged or worn teeth.

Remove burrs and rough spots with a honing stone or crocus cloth before installation. Lubricate mating surfaces before pressing gears on shafts.

Shafts

If a shaft does not come out easily, check that all nuts, bolts or retaining rings have been removed. Check to see if other parts are in the way before using force.

Shafts fitted to tapered splines should be very tight. If shafts are not tight, disassemble and inspect tapered splines. Discard parts that are worn. Be sure tapered splines are clean, dry and free of burrs before putting them in place. Press mating parts together tightly.

Clean all rust from the machined surfaces of new parts.

Part Replacement

Always replace worn or damaged parts with new parts.

CLEANING

Part Protection

Before cleaning, protect rubber parts (such as hoses, boots and electrical insulation) from cleaning solutions. Use a grease-proof barrier material. Remove the rubber part if it cannot be properly protected.

Cleaning Process

Any cleaning method may be used as long as it does not result in parts damage. Thorough cleaning is necessary for proper parts inspection. Strip rusted paint areas to bare metal before repainting.

Rust or Corrosion Removal

Remove rust and corrosion with a wire brush, abrasive cloth, sand blasting, vapor blasting or rust remover. Use buffing crocus cloth on highly polished parts that are rusted.

Bearings

Remove shields and seals from bearings before cleaning. Clean bearings with permanent shields and seals in solution.

Clean open bearings by soaking them in a petroleum cleaning solution. Never use a solution that contains chlorine.

Let bearings stand and dry. Do not dry using compressed air. Do not spin bearings while they are drying.

AIR TOOLS

- Always use approved eye protection equipment when performing any task using air-operated tools.
- On all power tools, use only recommended accessories with proper capacity ratings.
- Do not exceed air pressure ratings of any power tools.
- Bits should be placed against work surface before air hammers are operated.
- Disconnect the air supply line to an air hammer before attaching a bit.
- Never point an air tool at yourself or another person.
- Protect bystanders with approved eye protection.

WRENCHES

- Never use an extension on a wrench handle.
- If possible, always pull on a wrench handle and adjust your stance to prevent a fall if something lets go.
- Never cock a wrench.
- Never use a hammer on any wrench other than a Striking Face wrench.
- Discard any wrench with broken or battered points.
- Never use a pipe wrench to bend, raise, or lift a pipe.

PLIERS/CUTTERS/PRYBARS

- Plastic or vinyl covered pliers handles are not intended to act as insulation; don't use on live electrical circuits.
- Don't use pliers or cutters for cutting hardened wire unless they were designed for that purpose.
- Always cut at right angles.
- Don't use any prybar as a chisel, punch, or hammer.

HAMMERS

- Never strike one hammer against a hardened object, such as another hammer.
- Always grasp a hammer handle firmly, close to the end.
- Strike the object with the full face of the hammer.
- Never work with a hammer which has a loose head.
- Discard hammer if face is chipped or mushroomed.
- Wear approved eye protection when using striking tools.
- Protect bystanders with approved eye protection.

PUNCHES/CHISELS

- Never use a punch or chisel with a chipped or mushroomed end; dress mushroomed chisels and punches with a file.
- Hold a chisel or a punch with a tool holder if possible.
- When using a chisel on a small piece, clamp the piece firmly in a vise, and chip toward the stationary jaw.
- Wear approved eye protection when using these tools.
- Protect bystanders with approved eye protection.

SCREWDRIVERS

- Don't use a screwdriver for prying, punching, chiseling, scoring, or scraping.
- Use the right type of screwdriver for the job; match the tip to the fastener.
- Don't interchange POZIDRIV®, PHILLIPS®, or REED AND PRINCE screwdrivers.
- Screwdriver handles are not intended to act as insulation; don't use on live electrical circuits.
- Don't use a screwdriver with rounded edges because it will slip – redress with a file.

RATCHETS AND HANDLES

- Periodically clean and lubricate ratchet mechanisms with a light grade oil. Do not replace parts individually; ratchets should be rebuilt with the entire contents of service kit.
- Never hammer or put a pipe extension on a ratchet or handle for added leverage.
- Always support the ratchet head when using socket extensions, but do not put your hand on the head or you may interfere with the action of its reversing mechanism.
- When breaking loose a fastener, apply a small amount of pressure as a test to be sure the ratchet's gear wheel is engaged with the pawl.

SOCKETS

- Never use hand sockets on power or impact wrenches.
- Select the right size socket for the job.
- Never cock any wrench or socket.

- Select only impact sockets for use with air or electric impact wrenches.
- Replace sockets showing cracks or wear.
- Keep sockets clean.
- Always use approved eye protection when using power or impact sockets.

STORAGE UNITS

- Don't open more than one loaded drawer at a time. Close each drawer before opening up another.
- Close lids and lock drawers and doors before moving storage units.
- Don't pull on a tool cabinet; push it in front of you.
- Set the brakes on the locking casters after the cabinet has been rolled to your work.

NOTES

SCHEDULED MAINTENANCE TABLE

The scheduled maintenance table beginning on this page lists the maintenance requirements for Touring models. If you are familiar with the procedures, just reference the table for the recommended maintenance interval as well as the required specifications. On the other hand, if more information is needed, turn to page 14 for the start of more detailed service procedures. For your added convenience, the adjacent chart lists the part numbers of required lubricants.

Lubricant		Part Number
Engine Oil		See Table 1-1.
Hydraulic Fork Oil, Type "E"		99884-80 (16 oz.)
D.O.T. 5 Hydraulic Brake Fluid		99902-77 (12 oz.)
Semi-Synthetic Transmission Lubricant	Quart	99892-84
	Case of Quarts	98853-96
	Gallon	99891-84
	Case of Gallons	98852-96
Primary Chaincase Lubricant	Quart	99887-84
	Gallon	99886-84
Clutch and Throttle Cable Lubricant		Super Oil 94968-85TV
Steering Head Bearing Lubricant		Special Purpose Grease 99857-97 (cartridge)
Electrical Contact Grease		99861-90

SCHEDULED MAINTENANCE TABLE

Service Operation	1	5	1	1	2	2	3	3	4	4	5	Service Data
	0	0	0	5	0	5	0	5	0	5	0	
	0	0	0	0	0	0	0	0	0	0	0	
	0	0	0	0	0	0	0	0	0	0	0	
	mi	mi	mi	mi	mi	mi	mi	mi	mi	mi	mi	
	1	8	1	2	3	4	4	5	6	7	8	
	6	0	0	4	2	0	8	6	4	2	0	
	0	0	0	0	0	0	0	0	0	0	0	
	0	0	0	0	0	0	0	0	0	0	0	
	km	km	km	km	km	km	km	km	km	km	km	
Battery	I	I	I	I	I	I	I	I	I	I	I	Check condition and clean connections.
Engine Oil	R	R	R	R	R	R	R	R	R	R	R	<i>Oil level</i> Separate HOT and COLD checks per procedure. <i>Oil capacity</i> 4 qt. (3.8 L) per chart in procedure.
Engine Oil Filter	R	R	R	R	R	R	R	R	R	R	R	Hand tighten 1/2-3/4 turn after gasket contact.

R – Replace or change

I – Inspect (adjust, clean or replace as required)

L – Lubricate (with specified lubricant)

X – Perform

T – Tighten to proper torque

D – Disassemble (lube and inspect as required)

Service Operation	1	5	1	1	2	2	3	3	4	4	5	Service Data
	0	0	0	0	0	0	0	0	0	0	0	
	mi	mi	mi	mi	mi	mi	mi	mi	mi	mi	mi	
	1	8	6	4	2	0	8	6	4	2	0	
	6	0	0	0	0	0	0	0	0	0	0	
	0	0	0	0	0	0	0	0	0	0	0	
	km	km	km	km	km	km	km	km	km	km	km	
Primary Chain Tension	I	I	I	I	I	I	I	I	I	I	I	<i>Deflection</i> Cold: 5/8-7/8 in. (15.9-22.2 mm) Hot: 3/8-5/8 in. (9.5-15.9 mm)
Primary Chain Lubricant	R	R	R	R	R	R	R	R	R	R	R	<i>Lubricant capacity</i> 32 oz (946 mL) Part No.'s 99887-84 (qt) 99886-84 (gal)
Clutch Adjustment	XL	XL	XL	XL	XL	XL	XL	XL	XL	XL	XL	<i>Free play at adjuster screw</i> 1/2-1 turn <i>Free play at hand lever</i> 1/16-1/8 in. (1.6-3.2 mm)
Transmission Lubricant	R	R	R	R	R	R	R	R	R	R	R	<i>Lubricant level</i> Dipstick at FULL with motorcycle level and filler plug resting on threads. <i>Lubricant capacity</i> 20-24 oz (590-710 mL) Part No.'s 99892-84 (qt), 99891-84 (gal) <i>Transmission drain plug torque</i> 14-21 ft-lbs (19-28 Nm). <i>Filler plug torque</i> 25-75 in-lbs (2.8-8.5 Nm)
Tire Condition and Pressure	I	I	I	I	I	I	I	I	I	I	I	See Table 1-3.
Wheel Spokes	I	I			I			I			I	<i>Spoke nipple torque</i> 40-50 in-lbs (4.5-5.6 Nm)

R – Replace or change

I – Inspect (adjust, clean or replace as required)

L – Lubricate (with specified lubricant)

X – Perform

T – Tighten to proper torque

D – Disassemble (lube and inspect as required)

Service Operation	1	5	1	1	2	2	3	3	4	4	5	Service Data
	0	0	0	0	0	0	0	0	0	0	0	
	mi	mi	mi	mi	mi	mi	mi	mi	mi	mi	mi	
	1	8	1	2	3	4	4	5	6	7	8	
	6	0	6	4	2	0	8	6	4	2	0	
	0	0	0	0	0	0	0	0	0	0	0	
	0	0	0	0	0	0	0	0	0	0	0	
	km	km	km	km	km	km	km	km	km	km	km	
Steering Head Bearings	L		L		L	I	L		L		D	Lubricate through neck fitting with <i>Special Purpose Grease</i> , Part No. 99857-97 (cartridge) For swing-by inspection or disassembly instructions, see Section 2.17.
Brake Fluid Reservoir Level and Condition	I	I	I	I	I	I	I	I	I	I	I	<i>D.O.T. 5 Brake fluid</i> Part No.'s 99902-77 (12 oz), 99901-77 (gal)
Brake Pad Linings and Discs	I	I	I	I	I	I	I	I	I	I	I	<i>Minimum brake pad thickness</i> 0.04 in. (1.02 mm)
Drive Belt	I	I	I	I	I	I	I	I	I	I	I	<i>On ground without rider</i> 5/16-3/8 in. (7.9-9.5 mm) in bottom strand with 10 lb. (4.5 kg) upward force
Rear Shock Absorbers	I	I	I	I	I	I	I	I	I	I	I	See Section 2.19.
Air Cleaner	I	I	I	I	I	I	I	I	I	I	I	<i>Air cleaner cover screw torque</i> 36-60 in-lbs (4-7 Nm)
Fuel Valve, Lines and Fittings	I	I	I	I	I	I	I	I	I	I	I	Check for leaks.
Fuel Tank Filter						I					I	<i>Hex fitting torque</i> 15-20 ft-lbs (20-27 Nm)
Enrichener Control	I	I	I	I	I	I	I	I	I	I	I	See Section 4.3.

R – Replace or change

I – Inspect (adjust, clean or replace as required)

L – Lubricate (with specified lubricant)

X – Perform

T – Tighten to proper torque

D – Disassemble (inspect and repack as required)

Service Operation	1	5	1	1	2	2	3	3	4	4	5	Service Data
	0	0	0	0	0	0	0	0	0	0	0	
	mi	mi	mi	mi	mi	mi	mi	mi	mi	mi	mi	
	1	8	1	2	3	4	4	5	6	7	8	
	6	0	6	4	2	0	8	6	4	2	0	
	0	0	0	0	0	0	0	0	0	0	0	
	0	0	0	0	0	0	0	0	0	0	0	
	km	km	km	km	km	km	km	km	km	km	km	
Throttle Cables	IL	IL	IL	IL	IL	IL	IL	IL	IL	IL	IL	Lubricant Part No. 94968-85TV- 1/4 fl. oz. Handlebar clamp screw torque 60-80 in-lbs (6.8-9.0 Nm) Switch housing screw torque 35-45 in-lbs (4-5 Nm)
Spark Plugs	I	I	R	I	R	I	R	I	R	I	R	Plug type HD-6R12 Plug gap 0.038-0.043 in. (0.97-1.09 mm) Plug torque 12-18 ft-lbs (16-24 Nm)
Electrical Components	I	I	I	I	I	I	I	I	I	I	I	Check for proper operation.
Engine Idle Speed	I	I	I	I	I	I	I	I	I	I	I	Idle speed 950-1050 rpm
Critical Fastener Torque	T		T		T		T		T		T	Verify tightness. See Table 1-6 .
Stabilizer Links and Engine Mounts			T		T		T		T		T	See ENGINE MOUNTS in Section 1.5.
Front Fork Oil												D Fork oil (Type E) Part No. 99884-80 (16 oz)
Road Test	X	X	X	X	X	X	X	X	X	X	X	-

R – Replace or change **I** – Inspect (adjust, clean or replace as required)

L – Lubricate (with specified lubricant)

X – Perform

T – Tighten to proper torque

D – Disassemble (lube and inspect as required)

SUBJECT	PAGE NO.
2.1 Specifications	2-1
2.2 Vehicle Identification Number (VIN)	2-5
2.3 Front Wheel	2-6
2.4 Rear Wheel	2-11
2.5 Checking Rim Runout	2-17
2.6 Wheel Lacing - 16 Inch Rim	2-18
2.7 Truing Laced Wheel	2-21
2.8 Tires And Tubes	2-23
2.9 Vehicle Alignment	2-27
2.10 Front Brake Master Cylinder	2-33
2.11 Rear Brake Master Cylinder	2-38
2.12 Front Brake Caliper	2-46
2.13 Rear Brake Caliper	2-53
2.14 Bleeding Hydraulic Brake System	2-59
2.15 Front Forks	2-60
2.16 Lower Fork Bracket Cover/Air Dam	2-70
2.17 Steering Head Bearings	2-71
2.18 Rear Air Suspension	2-75
2.19 Rear Shock Absorbers	2-79
2.20 Rear Swingarm	2-81
2.21 Throttle Cables (Non-Ultra)	2-88
2.22 Clutch Cable	2-93
2.23 Handlebars	2-97
2.24 Seat	2-101
2.25 Saddlebags	2-105
2.26 Tour-Pak	2-112
2.27 Tour-Pak Lights/Backrest/Speaker Box	2-115
2.28 Lower Fairing/Engine Guard	2-119
2.29 Upper Fairing/Windshield (FLHT/C/U)	2-120
2.30 Upper Fairing/Windshield (FLTR)	2-127
2.31 Windshield/Headlamp Nacelle (FLHR/C/S)	2-137
2.32 Front Fender	2-141
2.33 Rear Fender	2-143
2.34 Jiffy Stand	2-146
2.35 Footboards/Footrests	2-148
2.36 Exhaust System	2-151

DIMENSIONS (IN.)

	FLHT/C/U	FLHR/C/S	FLTR
Wheel Base	63.5	63.5	63.5
Overall Length	93.7/97.5/98.3	93.7	93.7
Overall Width	39.0	34.45/34.45/39.40	35.75
Road Clearance	5.12	5.12/5.12/4.70	5.12
Overall Height	61.0	55.06/55.06/46.40	55.0
Saddle Height*	27.3	27.3/26.9/26.1	26.9

* With 180 Lb. Rider

DIMENSIONS (MM)

	FLHT/C/U	FLHR/C/S	FLTR
Wheel Base	1613	1613	1613
Overall Length	2380/2476/2497	2380	2380
Overall Width	990	875/875/1001	908
Road Clearance	130	130/130/119	130
Overall Height	1549	1399/1399/1179	1397
Saddle Height*	693	693/683/663	683

* With 81.6 kg Rider

WEIGHT (LBS.)

	FLHT/C/U	FLHR/C/S	FLTR
DRY WEIGHT**	758/776/788	723/710/721	731
GVWR	1259	1259	1259
GAWR – Front	500	500	500
GAWR – Rear	827	827	827

** As shipped from the factory

WEIGHT (KG)

	FLHT/C/U	FLHR/C/S	FLTR
DRY WEIGHT**	344/352/358	328/322/327	332
GVWR	571	571	571
GAWR – Front	227	227	227
GAWR – Rear	375	375	375

** As shipped from the factory

NOTE

Gross Vehicle Weight Rating (GVWR) (maximum allowable loaded vehicle weight) and corresponding Gross Axle Weight Ratings (GAWR) are given on a label located on the inside of the right front frame downtube.

CAPACITIES (U.S.)

	FLHT/C/U	FLHR/C/S	FLTR
Fuel Tank (gallons) Total*** Reserve	5 0.9	5 0.9	5 0.9
Oil Tank (quarts) with filter	4	4	4
Transmission (Ounces, approximate)	20-24	20-24	20-24
Primary Chaincase (Ounces, approximate)	32	32	32
Front Fork (Ounces)	Left 10.0 Right 11.1	Left 11.1 Right 11.1	Left 10.0 Right 11.1

*** Includes Reserve on Carbureted Models

CAPACITIES (METRIC)

	FLHT/C/U	FLHR/C/S	FLTR
Fuel Tank (liters) Total*** Reserve	18.9 3.4	18.9 3.4	18.9 3.4
Oil Tank (liters) with filter	3.78	3.78	3.78
Transmission (Milliliters)	591-710	591-710	591-710
Primary Chaincase (Milliliters)	946	946	946
Front Fork (Milliliters)	Left 295 Right 328	Left 328 Right 328	Left 295 Right 328

*** Includes Reserve on Carbureted Models

TIRE DATA

WARNING

Tires, rims and air valves must be correctly matched to wheel rims. See your Harley-Davidson dealer for service. Mismatching tires, tubes, rims and air valves may result in damage to the tire bead during mounting or may allow the tire to slip on the rim, possibly causing tire failure, which could result in death or serious injury.

WARNING

Using tires in ways other than those specified below may adversely affect motorcycle stability. Instability may lead to loss of vehicle control, which could result in death or serious injury.

- Use tubeless tires on all Harley-Davidson cast and disc wheels.
- Tubeless tires fitted with the correct size inner tubes also may be used on all Harley-davidson laced wheels, but protective rubber rim strips must be installed to prevent damage to the inner tubes.
- Do not use inner tubes in radial tires. Do not use radial tires on laced wheels.
- Always use the correct size tires and tubes. Tire sizes are molded on the tire sidewall. Tube sizes are printed on the tube.

WARNING

Maximum inflation pressure must not exceed specification on tire sidewall. Exceeding inflation specifications can adversely affect handling or result in tire failure, which could result in death or serious injury.

Dunlop Tires Only	Tire Pressure (Cold)			
	Front		Rear	
	PSI	BARS	PSI	BARS
Solo Rider	36	2.5	36	2.5
Rider & One Passenger	36	2.5	40	2.8

REAR WHEEL SPROCKET

All Models 70 teeth

TORQUE VALUES

Item	ft/in-lbs	Nm
Front brake disc TORX screws	16-24 ft-lbs	22-33 Nm
Front axle nut	50-55 ft-lbs	68-75 Nm
Front axle holder nuts	132-180 in-lbs	14.9-20.3 Nm
Front brake caliper mounting bolts	28-38 ft-lbs	37.9-51.5 Nm
Rear brake disc TORX screws	30-45 ft-lbs	41-61 Nm
Rear wheel sprocket bolts	55-65 ft-lbs	75-88 Nm
Rear axle cone nut	95-105 ft-lbs	129-142 Nm
Wheel spokes	40-50 in-lbs	4.5-5.6 Nm
Front engine mount to frame bolts	15-20 ft-lbs	20-27 Nm
Front engine mounting bracket to rubber mount bolt	15-20 ft-lbs	20-27 Nm
Voltage regulator locknuts	70-100 in-lbs	7.9-11.3 Nm
Handlebar clamp to master cylinder housing TORX screws	60-80 in-lbs	6.8-9.0 Nm
Brake caliper bleeder valve	80-100 in-lbs	9.0-11.3 Nm
Rear brake pedal shaft locknut	15-20 ft-lbs	20-27 Nm
Brake pedal/master cylinder assembly to mounting bracket hex nut	30-40 ft-lbs	41-54 Nm
Banjo bolt to master cylinder	17-22 ft-lbs	23-30 Nm
Banjo bolt to brake caliper	17-22 ft-lbs	23-30 Nm
Fairing lower U-bolt retainer locknuts	35-40 in-lbs	4.0-4.5 Nm
Fairing lower to engine guard clamp TORX screw	90-100 in-lbs	10.2-11.3 Nm
Fairing lower cap screws	10-15 in-lbs	1.1-1.7 Nm
Front brake master cylinder reservoir cover screws	6-8 in-lbs	0.7-0.9 Nm
Rear brake master cylinder reservoir cover screws	6-8 in-lbs	0.7-0.9 Nm
Brake caliper pad pins	180-200 in-lbs	20-23 Nm
Brake caliper bridge bolts	28-38 ft-lbs	38-52 Nm
Continued ...		

TORQUE VALUES (CONT'D)

Item	ft/in-lbs	Nm
Fork oil drain plugs	72-96 in-lbs	8-11 Nm
Fork pinch bolts	30-35 ft-lbs	41-48 Nm
Fork stem nut	60-80 ft-lbs	81-109 Nm
Fork tube plug	22-58 ft-lbs	30-79 Nm
Fork cap bolt	50-60 ft-lbs	68-81 Nm
Damper rod/cartridge 6mm screw	132-216 in-lbs	14.9-24.4 Nm
Damper rod locknut (cartridge type fork)	13-20 ft-lbs	18-27 Nm
Shock bottom mounting bolt	35-40 ft-lbs	47-54 Nm
Shock top mounting bolt	33-35 ft-lbs	45-48 Nm
Rear swingarm bracket bolts	34-42 ft-lbs	46-57 Nm
Rear swingarm pivot shaft locknut	40-45 ft-lbs	54-61 Nm
Handlebar switch housing TORX screws	35-45 in-lbs	4-5 Nm
Handlebar clamp to clutch lever bracket screws	60-80 in-lbs	6.8-9.0 Nm
Clutch release cover socket head screws	120-144 in-lbs	13.6-16.3 Nm
Clutch cable fitting	36-60 in-lbs	4-7 Nm
Transmission lubricant drain plug	14-21 ft-lbs	19-28 Nm
Transmission filler plug/ dipstick	25-75 in-lbs	2.8-8.5 Nm
Battery cable bolt	60-96 in-lbs	6.8-10.9 Nm
Tour-Pak mounting bolts	96-120 in-lbs	10.8-13.5 Nm
Inner fairing screws	20-30 in-lbs	2.3-3.4 Nm
Outer fairing screws (below windshield)	25-30 in-lbs	2.8-3.4 Nm
Fairing cap TORX screws	25-30 in-lbs	2.8-3.4 Nm
Speedometer/tachometer bracket socket screws	10-20 in-lbs	1.1-2.3 Nm
2 inch diameter gauge nuts	10-20 in-lbs	1.1-2.3 Nm
Passing lamp bracket fork bracket TORX bolts	15-20 ft-lbs	20-27 Nm
Windshield wellnut screws (FLTR)	6-13 in-lbs	0.7-1.5 Nm
Front turn signal lamp bracket stud acorn nuts (FLTR)	40-50 in-lbs	4.5-5.7 Nm
Continued ...		

Item	ft/in-lbs	Nm	
Short fairing screws (FLTR)	6-12 in-lbs	0.7-1.4 Nm	
Long fairing screws (FLTR)	10-15 in-lbs	1.1-1.7 Nm	
Instrument bezel TORX screws (FLTR)	25-35 in-lbs	2.8-4.0 Nm	
Instrument nacelle to fork bracket TORX bolts (FLTR)	15-20 ft-lbs	20-27 Nm	
Fairing bracket/steering head thru bolt (FLTR)	20-30 ft-lbs	27.1-40.7 Nm	
Radio bracket/inner fairing to fairing bracket stud lock- nuts (FLTR)	96-144 in-lbs	10.9-16.3 Nm	
Headlamp nacelle handle- bar clamp shroud Phillips screw	10-20 in-lbs	1.1-2.3 Nm	
Headlamp nacelle trim strip flange nut	15-20 in-lbs	1.7-2.3 Nm	
Passing lamp bracket fork bracket stud acorn nuts	72-108 in-lbs	8.1-12.2 Nm	
Front fender mounting bolts	16-20 ft-lbs	22-27 Nm	
Rear fender TORX bolts	15-20 ft-lbs	20-27 Nm	
Jiffy stand leg stop flange nut	43-53 ft-lbs	58-72 Nm	
Intake flange adapter screws	96-144 in-lbs	10.9-16.3 Nm	
Exhaust flange adapter nuts	100-120 in-lbs	11.3-13.6 Nm	
Exhaust pipe TORCA clamps	45-60 ft-lbs	61-81 Nm	
Heat shield worm drive clamps	20-40 in-lbs	2.3-4.5 Nm	
Transmission exhaust bracket clamp bolt	60-96 in-lbs	6.8-10.8 Nm	
Passenger footboard/ footrest socket screws	15-18 ft-lbs	20-24 Nm	
Rider footboard pivot bolt nut	84-108 in-lbs	9.5-12.2 Nm	
Air valve mount hex nut	40-50 in-lbs	4.5-5.6 Nm	
Handlebar upper clamp screws	12-16 ft-lbs	16.3-21.7 Nm	
Handlebar lower clamp bolts (risers)	30-40 ft-lbs	40.7-54.2 Nm	
Ignition switch nut	DOM	50-70 in-lbs	5.7-7.9 Nm
	HDI	125-150 in-lbs	14.1-16.9 Nm
Speaker box to Tour-Pak bolts	25-35 in-lbs	2.8-4.0 Nm	
Throttle cable J-clamp screw to wellnut (FLHR/C)	9-18 in-lbs	1.0-2.0 Nm	

NOTES

VEHICLE IDENTIFICATION NUMBER (VIN)

A 17-digit serial number, or Vehicle Identification Number (VIN), is stamped on the right side of the frame backbone at the rear of the steering head (and under the main harness conduit). A label bearing the VIN code is also affixed to the left side of the steering head. An abbreviated VIN is stamped between the front and rear cylinders on the left side of the crankcase.

NOTE

Always give the complete VIN when ordering parts or making an inquiry about your motorcycle.

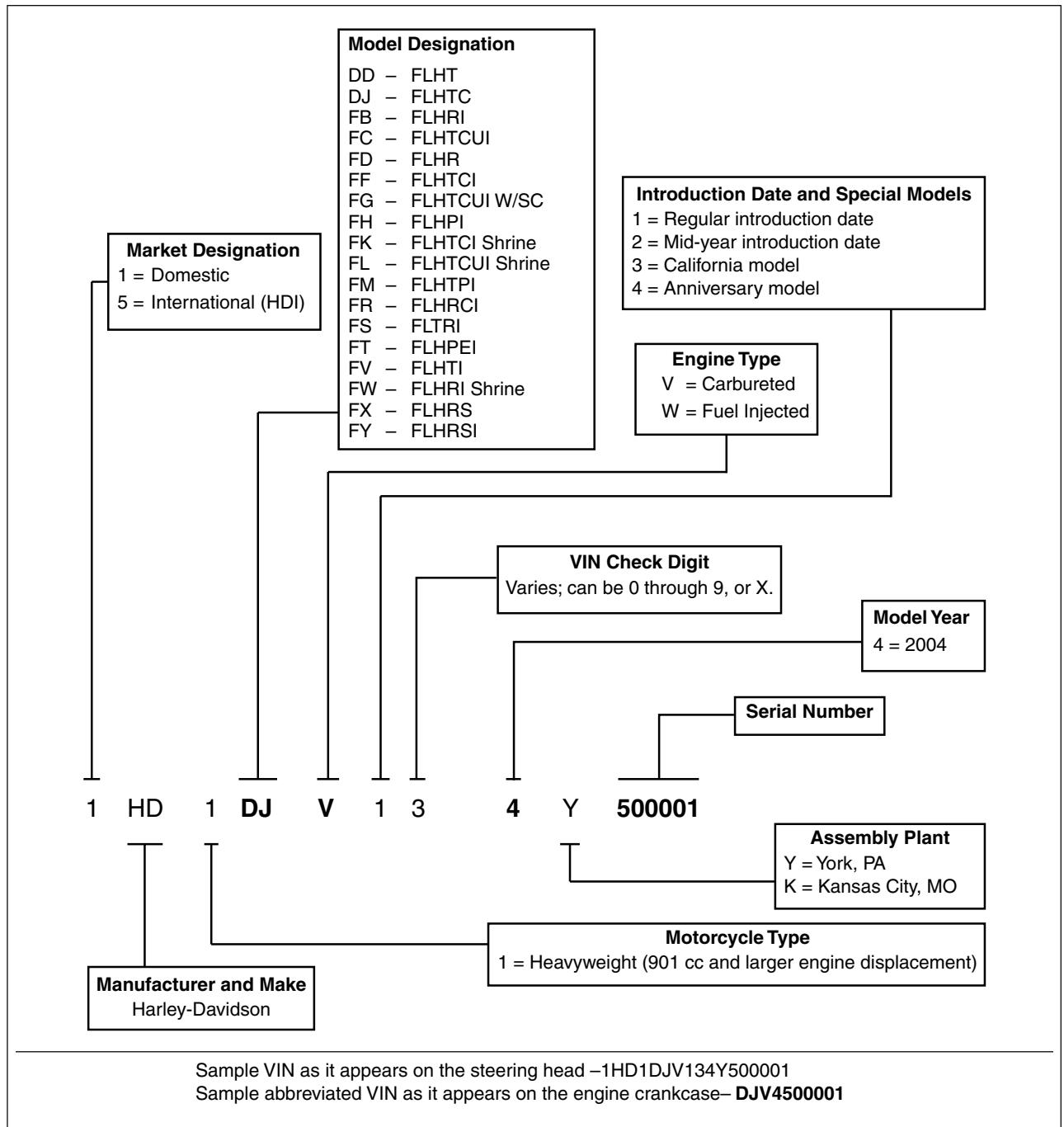

Figure 2-1. Vehicle Identification Number (VIN)

GENERAL

Maximum tire mileage and good handling qualities are directly related to care given wheels and tires. Wheels and tires should be regularly inspected for wear. If handling problems occur, see Section 1.1 TROUBLESHOOTING, HANDLING, for possible causes.

Always keep tires inflated to the recommended pressure and balance the wheel whenever a tire or tube is replaced.

PRELIMINARY INSPECTION

1. Measure brake disc thickness for excessive wear. Minimum acceptable thickness is stamped on side of disc. Also replace discs if warped or badly scored. Obtain **new** T40 TORX screws if brake discs were removed.
2. Whenever the wheel is removed for tire replacement or any other purpose, inspect the wheel bearings as follows:
 - a. Insert finger into wheel bearing and rotate the inner race in both directions. Repeat step on opposite side of wheel.
 - b. Replace the wheel bearings if there is rough rotation, abnormal noise or anything unusual. Always replace wheel bearings as a set. Never replace just one wheel bearing.

REMOVAL

1. Use shop rag or tape to protect fender area adjacent to caliper, as incidental contact can occur during caliper removal.



Figure 2-2. Inspect Wheel Bearings

2. Remove both the upper and lower mounting bolts from lugs of front fork leg to release brake caliper assembly.
3. Lift caliper upward to remove from brake disc. Allow the caliper to hang loose.
4. Repeat steps 1 thru 3 to release caliper on opposite side of wheel.

NOTE

Do not operate the front brake hand lever with the front wheel removed or the caliper pistons may be forced out. Reseating pistons requires disassembly of the caliper.

5. Insert screwdriver or steel rod through hole in axle on right side of vehicle. While holding axle stationary, remove the axle nut, lockwasher and flat washer on the left side.
6. Loosen the two axle holder nuts at bottom of right side fork leg.
7. With soft mallet, tap axle toward right side of vehicle until loose. Catching external spacers on left and right side, pull axle from hub while supporting wheel.
8. Move wheel to bench area and inspect bearings. See [PRELIMINARY INSPECTION](#) on this page.

DISASSEMBLY

1. If wheel bearing replacement is necessary, proceed as follows:
 - a. Obtain the WHEEL BEARING REMOVER/INSTALLER (HD-44060). Pick out the wheel bearing remover tools for the front wheel. See [Figure 2-3](#).
 - b. To prolong service life and ensure smooth operation, sparingly apply graphite lubricant to threads of forcing screw.
 - c. Install hex nut, flat washer and Nice bearing on forcing screw. Insert end of forcing screw through hole in bridge.
 - d. Install steel ball inside **larger** collet. Install collet at end of forcing screw.
 - e. Insert collet into bearing ID. Feel for inside edge of bearing using lip at end of collet and then back off slightly.
 - f. Holding forcing screw to prevent rotation, turn hex on collet until lip makes firm contact with inside edge of bearing. See upper frame of [Figure 2-4](#).

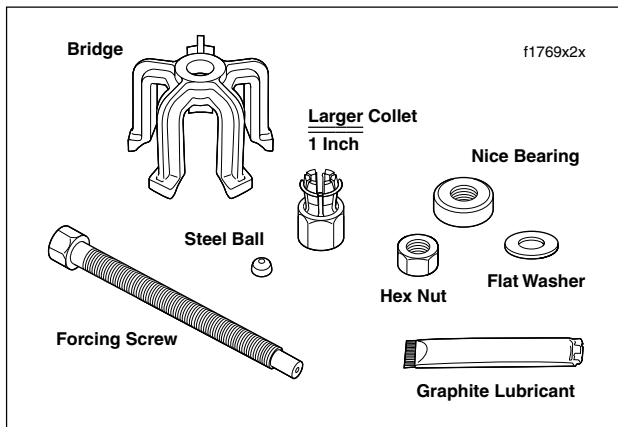

**Figure 2-3. Front Wheel Bearing Remover Tools
(Part No. HD-44060)**

- g. Holding forcing screw, turn hex nut until bearing is free. See lower frame of [Figure 2-4](#).
 - h. Remove spacer sleeve from wheel hub.
 - i. Repeat procedure to remove bearing on opposite side of wheel. Discard bearings.
2. If brake disc replacement is necessary, use a T40 TORX drive head and remove five screws securing brake disc to hub. Discard TORX screws. Repeat procedure to remove disc on opposite side of wheel. If the wheel is to be assembled with the same discs, mark both the wheel and discs, so that they can be installed in their original positions.
 3. If tire replacement is necessary, see Section 2.8 [TIRES AND TUBES](#).
 4. If the wheel is laced, and hub, spoke or rim replacement is necessary, loosen all spoke nipples and disassemble hub from rim.

CLEANING AND INSPECTION

1. Thoroughly clean all parts in solvent.
2. Inspect all parts for damage or excessive wear.
3. Always replace bearing assemblies as a complete set.
4. Inspect brake discs. Replace discs if warped or badly scored. Measure disc thickness for excessive wear. Minimum acceptable thickness is stamped on side of disc.

ASSEMBLY

1. On laced wheels, if the hub and rim were disassembled, assemble the hub, spokes and rim. See Section 2.6 [WHEEL LACING - 16 INCH RIM](#).

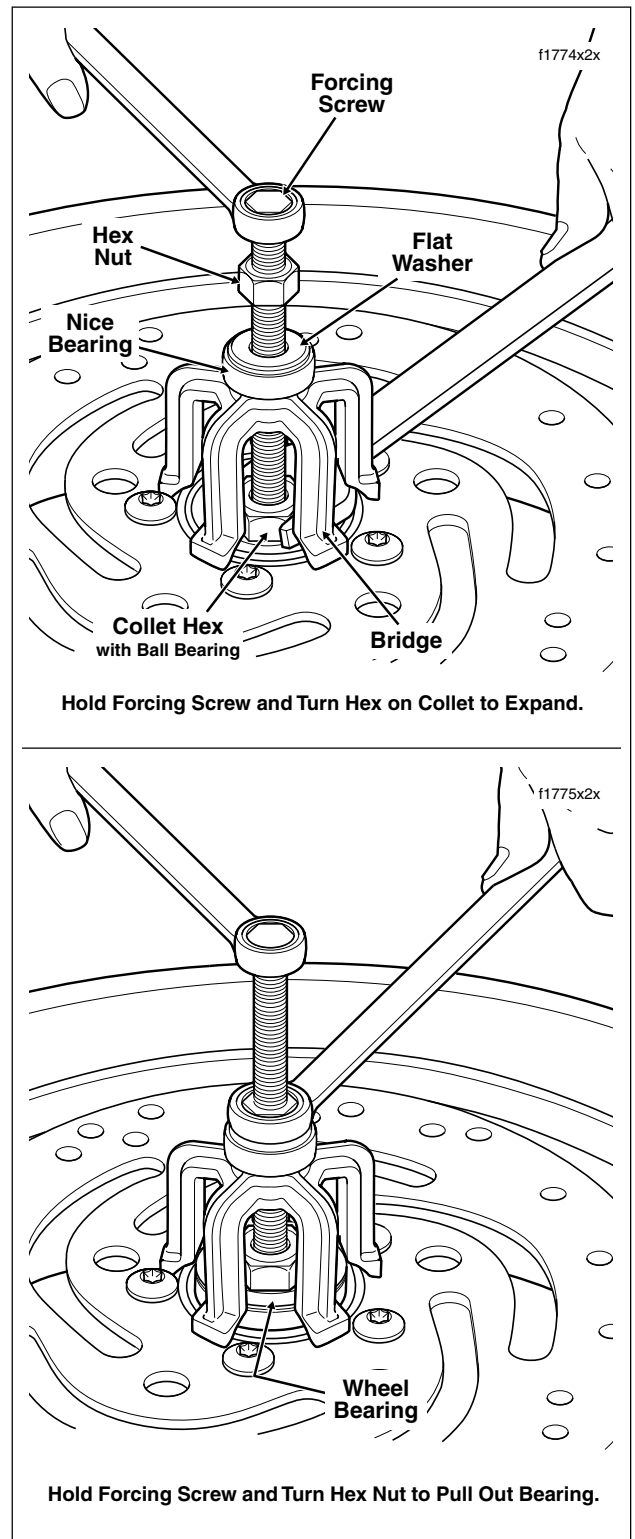

Figure 2-4. Remove Sealed Wheel Bearings

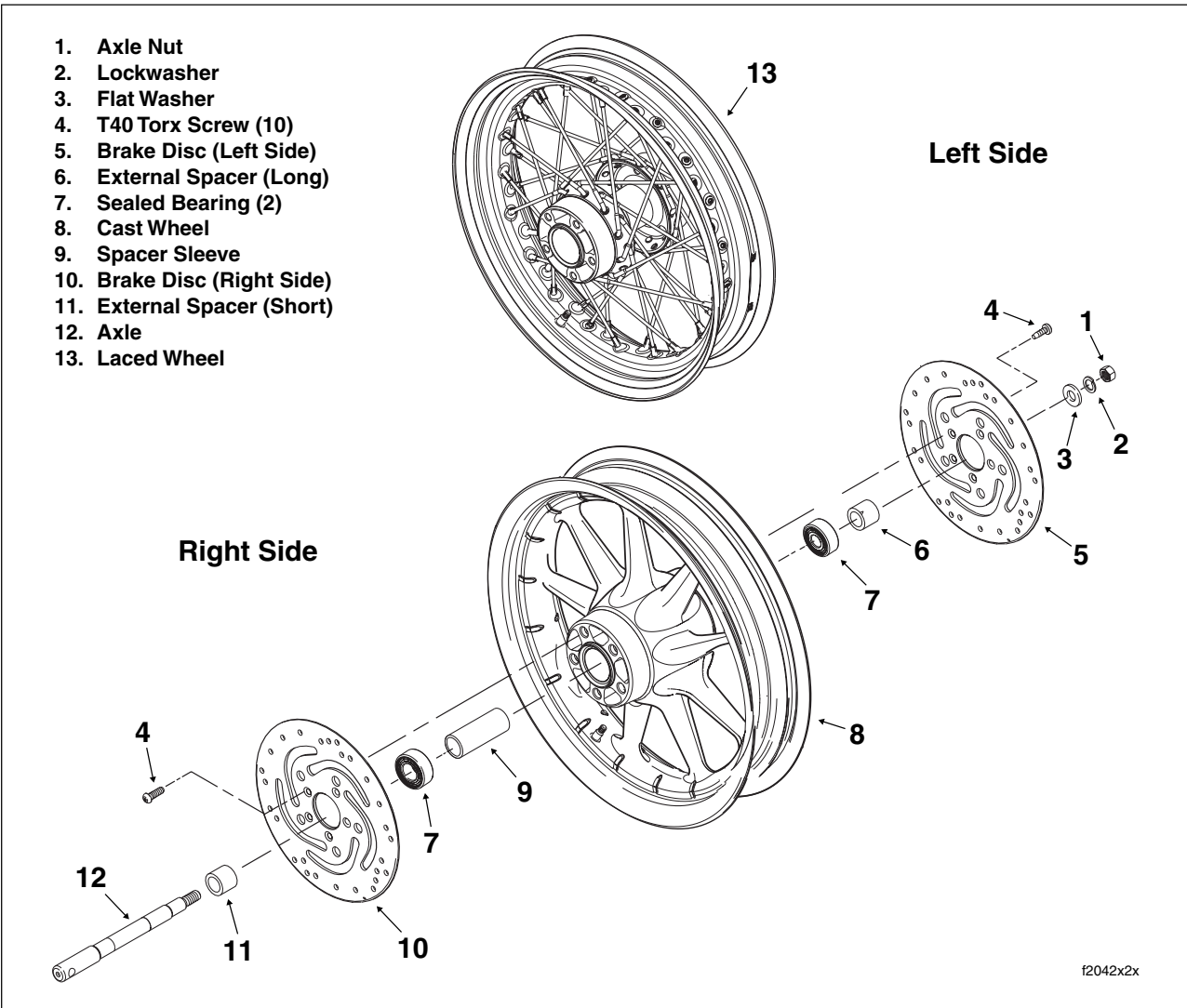

Figure 2-5. Front Wheel (Exploded View)

WARNING

Do not allow brake fluid or other lubricants to contact the brake disc. Such contact can adversely affect braking ability, which could result in death or serious injury.

2. Using a T40 TORX drive head, install brake discs on hub using **new** screws. Be sure to install discs in their original positions. Alternately tighten screws to 16-24 ft-lbs (22-33 Nm).

3. Install **new** wheel bearings as follows:

NOTE

Always install first of two bearings on the left side (opposite the valve stem side of the wheel).

- Obtain the WHEEL BEARING REMOVER/INSTALLER (HD-44060). Pick out the wheel bearing installer tools for the front wheel. See [Figure 2-6](#).
- To prolong service life and ensure smooth operation, sparingly apply graphite lubricant to threads of threaded rod.
- Slide support plate onto threaded rod. Slide rod through hub on the valve stem side of the wheel. See upper frame of [Figure 2-7](#).
- On opposite side of wheel, slide bearing onto threaded rod with lettered side facing outboard.
- Install **larger** pilot, Nice bearing, flat washer and hex nut onto rod.



Suggest:

For more complete manuals. Please go to the home page.

<https://www.ebooklibonline.com>

If the above button click is invalid. Please download this document first, and then click the above link to download the complete manual.

Thank you so much for reading

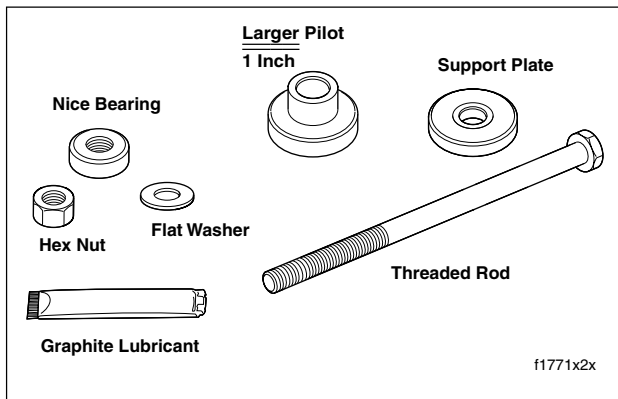

**Figure 2-6. Front Wheel Bearing Installer Tools
(Part No. HD-44060)**

- f. Holding threaded rod on opposite side of wheel to prevent rotation, turn hex nut to install bearing. See lower frame of [Figure 2-7](#). Bearing is fully seated when it makes firm contact with the counterbore.
 - g. Disassemble and remove tool, but leave support plate on threaded rod.
 - h. Slide threaded rod through installed wheel bearing and hub of wheel.
 - i. On the valve stem side of the wheel, slide spacer sleeve down threaded rod until it contacts installed wheel bearing.
 - j. Repeat steps 3(d) through 3(g) to complete installation of second wheel bearing. Bearing is fully seated when hex nut can no longer be turned.
4. Verify that wheel is true. See CHECKING CAST RIM RUNOUT or TRUING LACED WHEEL, whichever applies.
 5. Install rim strip on wheel rim, if applicable. Install tube and tire, if applicable. Verify that wheel is balanced.

INSTALLATION

1. Place wheel into position between forks with the valve stem on the right side of the vehicle.
2. Coat the axle with ANTI-SIEZE LUBRICANT.
3. Supporting wheel, insert threaded end of axle through right fork leg. Push axle through fork, **short** external spacer and wheel hub until it begins to emerge from left side.
4. With the three notches on the bearing side, push axle through **long** external spacer and left fork leg until axle shoulder contacts external spacer on right fork side.

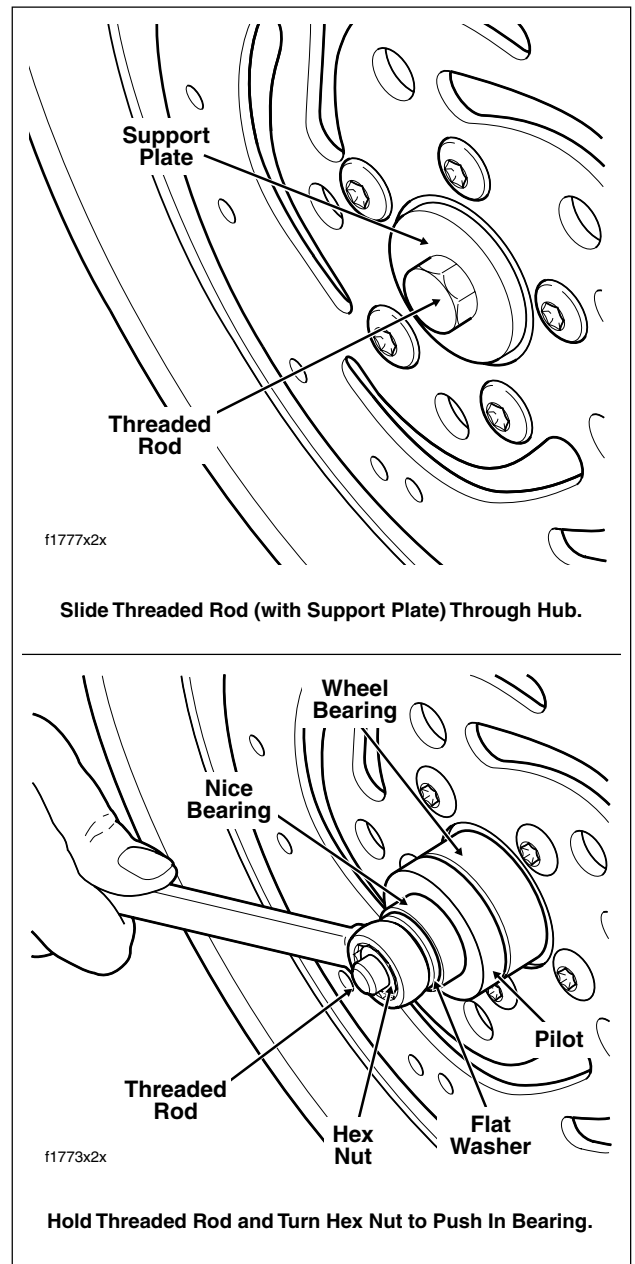

Figure 2-7. Install Sealed Wheel Bearings

5. Install flat washer, lockwasher and axle nut.
6. Insert screwdriver or steel rod through hole in axle on right side of vehicle. While holding axle stationary, tighten axle nut to 50-55 ft-lbs (68-75 Nm).
7. Insert 7/16 inch drill bit into hole in axle. See [Figure 2-8](#).
8. Pull fork leg so that it just contacts drill bit, and then tighten axle holder nuts to 132-180 **in-lbs** (14.9-20.3 Nm).

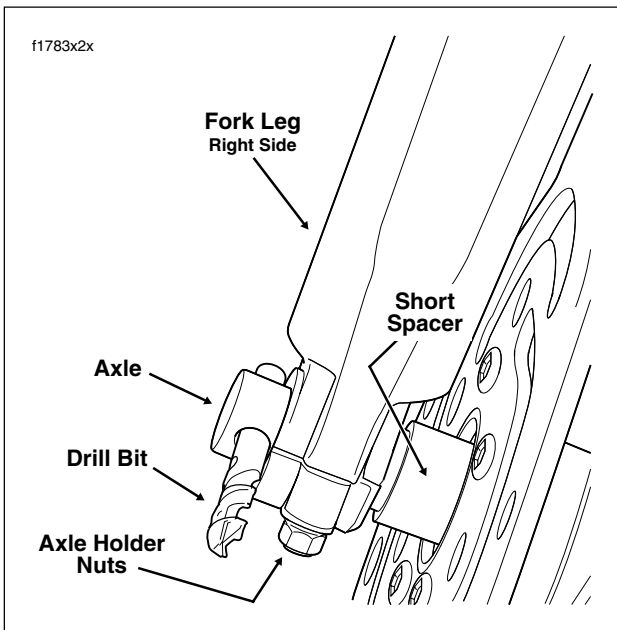

Figure 2-8. Align Front Wheel

9. Remove drill bit from axle hole.
10. Install brake caliper as follows:
 - a. Use shop rag or tape to protect fender area adjacent to caliper, as incidental contact can occur during caliper installation.
 - b. With the bleeder valve topside, position caliper so that brake disc is situated between friction pads. Pry inner and outer brake pads back for additional clearance, if necessary.
 - c. Align upper mounting hole in caliper with upper mounting lug on fork leg. Loosely install long caliper mounting bolt into upper lug of fork leg.
 - d. Install short caliper mounting bolt into lower lug of fork leg. Tighten lower mounting bolt to 28-38 ft-lbs (37.9-51.5 Nm).
 - e. Tighten upper caliper mounting bolt to 28-38 ft-lbs (37.9-51.5 Nm).
 - f. Repeat step 10 to install caliper on opposite side of wheel.

⚠ WARNING

After installation of calipers and **BEFORE** moving motorcycle, pump front brake hand lever until pistons push pads against the brake discs. If fluid pressure is not pumped up, the brake will not be available the first time it is used, a situation that could result in death or serious injury.

11. Depress front brake hand lever several times to set brake pads to proper operating position within caliper.

<https://www.ebooklibonline.com>

Hello dear friend!

Thank you very much for reading.

Enter the link into your browser.

The full manual is available for immediate download.

<https://www.ebooklibonline.com>