

# 2003 XLH MODELS

---

## SERVICE MANUAL

---

### Part Number 99484-03

Section 1: Product

Section 2: Chassis

Section 3: Engine

Section 4: Fuel System

Section 5: Starter

Section 6: Drive/Transmission

Section 7: Electrical

Appendix

## ELECTRICAL DIAGNOSTICS

---

### Part Number 99495-03

Section 1: Starting & Charging

Section 2: Instruments

Section 3: Turn Signals

Section 4: Engine Management

Section 5: Wiring

<b>SUBJECT</b>	<b>PAGE NO.</b>
1.1 General	1-1
1.2 Fuel and Oil	1-5
1.3 Maintenance Schedule	1-6
1.4 Engine Oil and Filter	1-8
1.5 Battery Maintenance	1-10
1.6 Brakes	1-13
1.7 Bleeding Hydraulic Brake System	1-15
1.8 Brake Pads and Discs	1-16
1.9 Tires and Wheels	1-19
1.10 Primary Chain	1-21
1.11 Clutch	1-22
1.12 Transmission Lubricant	1-24
1.13 Rear Belt Deflection	1-25
1.14 Rear Belt and Sprockets	1-27
1.15 Suspension Adjustments	1-29
1.16 Steering Head Bearings	1-33
1.17 Front Fork Oil	1-35
1.18 Spark Plugs	1-36
1.19 Air Cleaner Filter	1-37
1.20 Cable and Chassis Lubrication	1-39
1.21 Throttle Cables and Enrichener	1-40
1.22 Idle Speed and Ignition Timing	1-42
1.23 Fuel Supply Valve Filter	1-46
1.24 Engine Mounts	1-48
1.25 Headlamp Alignment	1-49
1.26 Critical Fasteners	1-50
1.27 Fluid Requirements	1-51
1.28 Storage	1-52
1.29 Troubleshooting	1-53

## SERVICING A NEW MOTORCYCLE

### WARNING

**Always follow the listed service and maintenance recommendations, since they affect the safe operation of the motorcycle and the personal welfare of the rider. Failure to follow recommendations could result in death or serious injury.**

Service operations to be performed before customer delivery are specified in the applicable model year PREDELIVERY AND SETUP MANUAL.

The performance of new motorcycle initial service is required to keep warranty in force and to ensure proper emissions systems operation.

After a new motorcycle has been driven its first 1000 miles (1600 km), and at every 2500 mile (4000 km) interval thereafter, have a Harley-Davidson dealer perform the service operations listed under [1.3 MAINTENANCE SCHEDULE](#).

## SAFE OPERATING MAINTENANCE

### CAUTION

- **Do not attempt to retighten engine head bolts. Retightening can cause engine damage.**
- **During the initial 1000 mile (1600 km) break-in period, use only Harley-Davidson 20W50 engine oil. Failure to use the recommended oil will result in improper break-in of the engine cylinders and piston rings.**

A careful check of certain equipment is necessary after periods of storage, and frequently between regular service intervals, to determine if additional maintenance is required.

Check:

1. Tires for abrasions, cuts and correct pressure.
2. Secondary drive belt for proper tension and condition.
3. Brakes, steering and throttle for responsiveness.
4. Brake fluid level and condition. Hydraulic lines and fittings for leaks. Also, check brake pads and rotors for wear.
5. Cables for fraying, crimping and free operation.
6. Engine oil and transmission fluid levels.
7. Headlamp, passing lamp, tail lamp, brake lamp and turn signal operation.

## SHOP PRACTICES

### Repair Notes

#### NOTE

- *General maintenance practices are given in this section.*
- *Repair = Disassembly/Assembly.*
- *Replace = Removal/Installation.*

All special tools and torque values are noted at the point of use.

All required parts or materials can be found in the appropriate PARTS CATALOG.

### Safety

Safety is always the most important consideration when performing any job. Be sure you have a complete understanding of the task to be performed. Use common sense. Use the proper tools. Protect yourself and bystanders with approved eye protection. Don't just do the job – do the job safely.

### Removing Parts

Always consider the weight of a part when lifting. Use a hoist whenever necessary. Do not lift heavy parts by hand. A hoist and adjustable lifting beam or sling are needed to remove some parts. The lengths of chains or cables from the hoist to the part should be equal and parallel and should be positioned directly over the center of the part. Be sure that no obstructions will interfere with the lifting operation. Never leave a part suspended in mid-air.

### WARNING

**Always check the capacity rating and condition of hoists, slings, chains or cables before use. Failure to do so could lead to an accident which could result in death or serious injury.**

Always use blocking or proper stands to support the part that has been hoisted. If a part cannot be removed, verify that all bolts and attaching hardware have been removed. Check to see if any parts are in the way of the part being removed.

When removing hoses, wiring or tubes, always tag each part to ensure proper installation.

### Cleaning

If you intend to reuse parts, follow good shop practice and thoroughly clean the parts before assembly. Keep all dirt out of parts; the unit will perform better and last longer. Seals, filters and covers are used in this vehicle to keep out environmental dirt and dust. These items must be kept in good condition to ensure satisfactory operation.

Clean and inspect all parts as they are removed. Be sure all holes and passages are clean and open. After cleaning, cover all parts with clean lint-free cloth, paper or other material. Be sure the part is clean when it is installed.

**<https://www.ebooklibonline.com>**

Hello dear friend!

Thank you very much for reading.

Enter the link into your browser.

The full manual is available for immediate download.

**<https://www.ebooklibonline.com>**

Always clean around lines or covers before they are removed. Plug, tape or cap holes and openings to keep out dirt, dust and debris.

Always verify cleanliness of blind holes before assembly. Tightening a screw with dirt, water or oil in the hole can cause castings to crack or break.

## Disassembly and Assembly

Always assemble or disassemble one part at a time. Do not work on two assemblies simultaneously. Be sure to make all necessary adjustments. Recheck your work when finished. Be sure that everything is done.

Operate the vehicle to perform any final check or adjustments. If all is correct, the vehicle is ready to go back to the customer.

# REPAIR AND REPLACEMENT PROCEDURES

---

## Hardware and Threaded Parts

Install helical thread inserts when inside threads in castings are stripped, damaged or not capable of withstanding specified torque.

Replace bolts, nuts, studs, washers, spacers and small common hardware if missing or in any way damaged. Clean up or repair minor thread damage with a suitable tap or die.

Replace all damaged or missing lubrication fittings.

Use Teflon pipe sealant on pipe fitting threads.

## Wiring, Hoses and Lines

Replace hoses, clamps, electrical wiring, electrical switches or fuel lines if they do not meet specifications.

## Instruments and Gauges

Replace broken or defective instruments and gauges. Replace dials and glass that are so scratched or discolored that reading is difficult.

## Bearings

Anti-friction bearings must be handled in a special way. To keep out dirt and abrasives, cover the bearings as soon as they are removed from the package.

Wash bearings in a non-flammable cleaning solution. Knock out packed lubricant inside by tapping the bearing against a wooden block. Wash bearings again. Cover bearings with clean material after setting them down to dry. Never use compressed air to dry bearings.

Coat bearings with clean oil. Wrap bearings in clean paper.

Be sure that the chamfered side of the bearing always faces the shoulder (when bearings installed against shoulders). Lubricate bearings and all metal contact surfaces before pressing into place. Only apply pressure on the part of the bearing that makes direct contact with the mating part.

Always use the proper tools and fixtures for removing and installing bearings.

Bearings do not usually need to be removed. Only remove bearings if necessary.

## Bushings

Do not remove a bushing unless damaged, excessively worn or loose in its bore. Press out bushings that must be replaced.

When pressing or driving bushings, be sure to apply pressure in line with the bushing bore. Use a bearing/bushing driver or a bar with a smooth, flat end. Never use a hammer to drive bushings.

Inspect the bushing and the mated part for oil holes. Be sure all oil holes are properly aligned.

## Gaskets

Always discard gaskets after removal. Replace with **new** gaskets. Never use the same gasket twice. Be sure that gasket holes match up with holes in the mating part.

## Lip Type Seals

Lip seals are used to seal oil or grease and are usually installed with the sealing lip facing the contained lubricant. Seal orientation, however, may vary under different applications.

Seals should not be removed unless necessary. Only remove seals if required to gain access to other parts or if seal damage or wear dictates replacement.

Leaking oil or grease usually means that a seal is damaged. Replace leaking seals to prevent overheated bearings.

Always discard seals after removal. Do not use the same seal twice.

## O-Rings (Preformed Packings)

Always discard O-rings after removal. Replace with **new** O-rings. To prevent leaks, lubricate the O-rings before installation. Apply the same type of lubricant as that being sealed. Be sure that all gasket, O-ring and seal mating surfaces are thoroughly clean before installation.

## Gears

Always check gears for damaged or worn teeth.

Lubricate mating surfaces before pressing gears on shafts.

## Shafts

If a shaft does not come out easily, check that all nuts, bolts or retaining rings have been removed. Check to see if other parts are in the way before using force.

Shafts fitted to tapered splines should be very tight. If shafts are not tight, disassemble and inspect tapered splines. Discard parts that are worn. Be sure tapered splines are clean, dry and free of burrs before putting them in place. Press mating parts together tightly.

Clean all rust from the machined surfaces of new parts.

## Part Replacement

Always replace worn or damaged parts with **new** parts.

## CLEANING

---

### Part Protection

Before cleaning, protect rubber parts (such as hoses, boots and electrical insulation) from cleaning solutions. Use a grease-proof barrier material. Remove the rubber part if it cannot be properly protected.

### Cleaning Process

Any cleaning method may be used as long as it does not result in parts damage. Thorough cleaning is necessary for proper parts inspection. Strip rusted paint areas to bare metal before repainting.

### Rust or Corrosion Removal

Remove rust and corrosion with a wire brush, abrasive cloth, sand blasting, vapor blasting or rust remover. Use buffing crocus cloth on highly polished parts that are rusted.

### Bearings

Clean open bearings by soaking them in a petroleum cleaning solution. Never use a solution that contains chlorine.

Let bearings stand and dry. Do not dry using compressed air. Do not spin bearings while they are drying.

## TOOL SAFETY

---

### Air Tools

- Always use approved eye protection equipment when performing any task using air-operated tools.
- On all power tools, use only recommended accessories with proper capacity ratings.
- Do not exceed air pressure ratings of any power tools.
- Bits should be placed against work surface before air hammers are operated.
- Disconnect the air supply line to an air hammer before attaching a bit.
- Never point an air tool at yourself or another person.
- Protect bystanders with approved eye protection.

### Wrenches

- Never use an extension on a wrench handle.
- If possible, always pull on a wrench handle and adjust your stance to prevent a fall if something lets go.
- Never cock a wrench.
- Never use a hammer on any wrench other than a STRIKING FACE wrench.
- Discard any wrench with broken or battered points.
- Never use a pipe wrench to bend, raise or lift a pipe.

### Pliers/cutters/prybars

- Plastic- or vinyl-covered pliers handles are not intended to act as insulation; don't use on live electrical circuits.
- Don't use pliers or cutters for cutting hardened wire unless they were designed for that purpose.
- Always cut at right angles.
- Don't use any prybar as a chisel, punch or hammer.

## Hammers

- Never strike one hammer against a hardened object, such as another hammer.
- Always grasp a hammer handle firmly, close to the end.
- Strike the object with the full face of the hammer.
- Never work with a hammer which has a loose head.
- Discard hammer if face is chipped or mushroomed.
- Wear approved eye protection when using striking tools.
- Protect bystanders with approved eye protection.

## Punches/chisels

- Never use a punch or chisel with a chipped or mushroomed end; dress mushroomed chisels and punches with a file.
- Hold a chisel or a punch with a tool holder if possible.
- When using a chisel on a small piece, clamp the piece firmly in a vise and chip toward the stationary jaw.
- Wear approved eye protection when using these tools.
- Protect bystanders with approved eye protection.

## Screwdrivers

- Don't use a screwdriver for prying, punching, chiseling, scoring or scraping.
- Use the right type of screwdriver for the job; match the tip to the fastener.
- Don't interchange POZIDRIV®, PHILLIPS® or REED AND PRINCE screwdrivers.
- Screwdriver handles are not intended to act as insulation; don't use on live electrical circuits.
- Don't use a screwdriver with rounded edges because it will slip – redress with a file.

## Ratchets and Handles

- Periodically clean and lubricate ratchet mechanisms with a light grade oil. Do not replace parts individually; ratchets should be rebuilt with the entire contents of service kit.
- Never hammer or put a pipe extension on a ratchet or handle for added leverage.
- Always support the ratchet head when using socket extensions, but do not put your hand on the head or you may interfere with the action of its reversing mechanism.
- When breaking loose a fastener, apply a small amount of pressure as a test to be sure the ratchet's gear wheel is engaged with the pawl.

## Sockets

- Never use hand sockets on power or impact wrenches.
- Select the right size socket for the job.
- Never cock any wrench or socket.
- Select only impact sockets for use with air or electric impact wrenches.
- Replace sockets showing cracks or wear.
- Keep sockets clean.
- Always use approved eye protection when using power or impact sockets.

## Storage Units

- Don't open more than one loaded drawer at a time. Close each drawer before opening up another.
- Close lids and lock drawers and doors before moving storage units.
- Don't pull on a tool cabinet; push it in front of you.
- Set the brakes on the locking casters after the cabinet has been rolled to your work.

## FUEL

### ⚠ WARNING

**Remove filler cap slowly and fill fuel tank slowly to prevent spillage; do not overfill or fill above the bottom of the filler neck insert. In addition, leave air space to allow for fuel expansion. Expansion can cause an overfilled tank to overflow gasoline through the filler cap onto surrounding areas. After refueling, be sure filler cap is securely tightened. Inadequate safety precautions may cause an explosion or fire which could result in death or serious injury.**

Harley-Davidson motorcycles were designed to obtain the best performance and efficiency using unleaded gasoline (91 pump octane or higher for the XL Sport, 87 or higher for all other models). Pump octane is the octane number usually shown on the gas pump. Some fuel suppliers sell gasoline/alcohol blends as a fuel. The type and amount of alcohol added to the fuel is important.

## GASOLINE BLENDS

### CAUTION

**Using gasoline that has an alcohol additive, such as methanol, may cause fuel system rubber components' failure and/or engine damage.**

Harley-Davidson motorcycles were designed to give the best performance using unleaded gasoline. Some fuel suppliers sell gasoline/alcohol blends as a fuel. The type and amount of alcohol added to the fuel is important.

- **DO NOT USE GASOLINES CONTAINING METHANOL.** Using gasoline/methanol blends will result in starting and driveability deterioration and damage to critical fuel system components.
- **ETHANOL** is a mixture of 10% ethanol (Grain alcohol) and 90% unleaded gasoline. It is identified as "gasohol," "ethanol enhanced," or "contains ethanol." Gasoline/ethanol blends can be used in your motorcycle if the ethanol content does not exceed 10%.
- **REFORMULATED OR OXYGENATED GASOLINES (RFG):** "Reformulated gasoline" is a term used to describe gasoline blends that are specifically designed to burn cleaner than other types of gasoline. Your motorcycle will run normally using this type of gas.

Because of their generally higher volatility, these blends may adversely affect the starting, driveability and fuel efficiency of your motorcycle. If you experience these problems, Harley-Davidson recommends you operate your motorcycle on straight, unleaded gasoline.

## ENGINE OIL

Use the proper grade of oil for the lowest temperature expected before the next oil change.

If it is necessary to add oil and Harley-Davidson oil is not available, use an oil certified for diesel engines. Acceptable diesel engine oil designations include CF, CF-4, CG-4 and CH-4. The preferred viscosities for the diesel engine oils, in descending order, are 20W-50, 15W-40 and 10W-40. At the first opportunity, see a Harley-Davidson dealer to change back to 100 percent Harley-Davidson oil.

See [1.4 ENGINE OIL AND FILTER](#) for all service information.

## WINTER LUBRICATION

Normal fuel combustion in a gasoline engine produces water vapor and carbon dioxide along with other gases and particulates. During starting and warm-up in cold weather, especially in freezing temperatures, the vapor condenses to water before the crankcase is hot enough to exhaust it through the breather system. If the engine is driven long enough to thoroughly warm the crankcase, most of this liquid water is again vaporized and exhausted through the crankcase breather system.

A moderately driven vehicle making short runs may not be able to vacate water vapors allowing liquid water to accumulate in the oil tank. This is especially true if the vehicle is operated in cold weather. In freezing weather, an accumulation of water in the engine oil may become slush or ice, which can block oil lines and lead to severe engine damage. Water remaining in the engine oil for long periods of time can form an acidic sludge that is corrosive to metal engine parts and causes accelerated wear of moving components.

Always change the engine oil more often in winter. The colder the weather, the shorter the recommended oil change interval. If the engine is used for short runs, change the oil even more frequently.



**Table 1-1. Maintenance Schedule**

MAINTENANCE TASK AND SERVICE DATA	P R E R I D E	1	2	5	7	1	1	1	1	2	2	2	2	3	3	3	3	4	4	4	4	5	5	7	7	8
		0	5	0	5	0	2	5	7	0	2	5	7	0	2	5	7	0	2	5	7	0	2	5	7	0
		MI	MI	MI	MI	MI	MI	MI	MI	MI	MI	MI	MI	MI	MI	MI	MI	MI	MI	MI	MI	MI	MI	MI	MI	MI
		1	4	8	1	1	2	2	2	3	3	4	4	4	5	5	6	6	6	7	7	8	0	0	0	0
		6	0	0	0	6	0	0	0	0	0	0	0	0	0	0	0	0	0	0	0	0	0	0	0	0
		0	0	0	0	0	0	0	0	0	0	0	0	0	0	0	0	0	0	0	0	0	0	0	0	0
		0	0	0	0	0	0	0	0	0	0	0	0	0	0	0	0	0	0	0	0	0	0	0	0	0
		K	K	K	K	K	K	K	K	K	K	K	K	K	K	K	K	K	K	K	K	K	K	K	K	K
		M	M	M	M	M	M	M	M	M	M	M	M	M	M	M	M	M	M	M	M	M	M	M	M	M
Clutch adjustment		A		A		A		A		A		A		A		A		A		A		A		A		
Ignition timing and MAP sensor (1200S) or vacuum-operated electric switch (V.O.E.S.)				I		I		I		I		I		I		I		I		I		I		I		
Bank angle sensor				I		I		I		I		I		I		I		I		I		I		I		
Operation of all electrical equipment and switches	I	I	I	I	I	I	I	I	I	I	I	I	I	I	I	I	I	I	I	I	I	I	I	I	I	
Spark plugs*				I		R		I		R		I		R		I		R		I		R		I		
Battery connections		T		T		T		T		T		T		T		T		T		T		T		T		
All fasteners except engine head bolts		T		T		T		T		T		T		T		T		T		T		T		T		
Road test	X	X	X	X	X	X	X	X	X	X	X	X	X	X	X	X	X	X	X	X	X	X	X	X	X	

**Table Code:**

- A - Adjust.
- I - Inspect, and if necessary, correct, adjust, clean or replace.
- L - Lubricate with specified lubricant.
- R - Replace or change.
- T - Tighten to proper torque.
- X - Perform.
- \* - Also perform prior to storage or annually.

## CHECKING AND ADDING OIL

Check engine oil level in oil tank at least once every 500 miles (800 km). Check level more frequently if engine uses more oil than normal or if vehicle is operated under harsh conditions. Oil tank capacity is three quarts (U.S.) (2.8 liters). Check table in [1.4 ENGINE OIL AND FILTER](#), [CHANGING OIL AND FILTER](#) for recommended engine oil viscosity.

1. Run engine until engine oil is at normal operating temperature. Turn engine off.
2. Hold motorcycle upright so that it is not leaning on jiffy stand. Remove filler cap from oil tank on right side of vehicle. Wipe attached dipstick clean.
3. Install filler cap onto oil tank. Make sure cap is fully seated on tank.
4. See [Figure 1-1](#). Remove filler cap and check warm oil level on dipstick. Dipstick has two marks. If oil level in tank is at or below lower mark, add one quart (0.946 liter) of Harley-Davidson oil to tank.
5. Repeat Steps 2-4 to verify correct engine oil level in oil tank. Do not fill oil tank to the level above upper mark on dipstick.

## CHANGING OIL AND FILTER

### General

After a new engine has run its first 1000 miles (1600 km), and at 5000 mile (8000 km) intervals or annually thereafter, completely drain oil tank of used oil. Refill with fresh oil. If vehicle is driven extremely hard, used in competition, or driven on dusty roads, change engine oil at shorter intervals. Always change oil filter when changing engine oil. Proceed as follows:

### Removal

1. Run engine until engine oil has reached normal operating temperature.
2. Place a suitable container under the engine crankcase. The container must be able to hold approximately three U.S. quarts (2.8 liters).
3. See [Figure 1-2](#). Locate the oil tank drain hose. The drain hose is secured to a lug on the rear muffler mount.

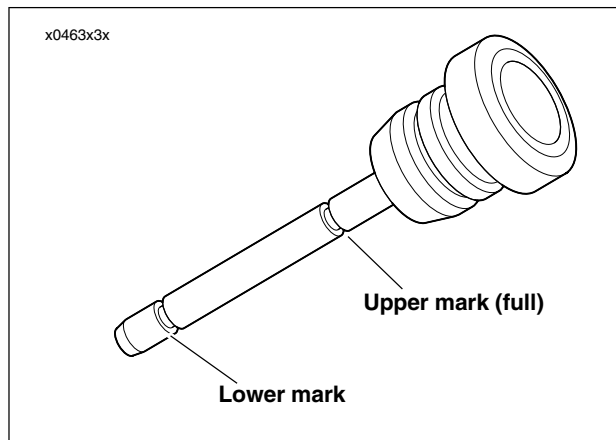

Figure 1-1. Oil Tank Filler Cap/Dipstick

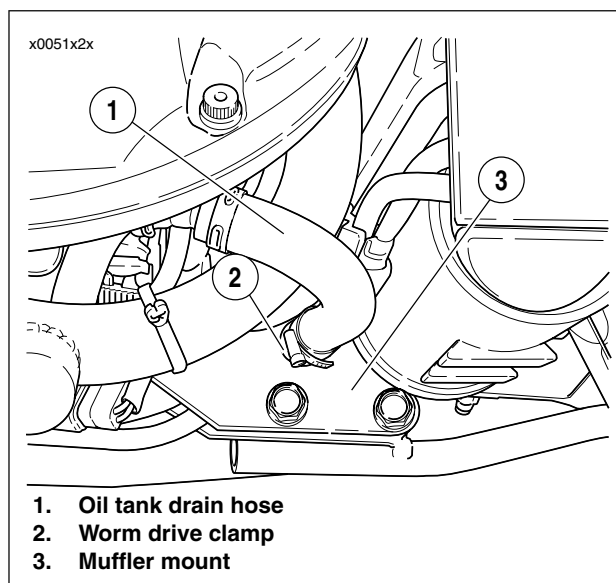

Figure 1-2. Oil Tank Drain Hose

- Remove the worm drive clamp, pull the drain hose from the lug and insert the free end into the container. Completely drain engine oil from oil tank. It is not necessary to drain engine crankcase.

**NOTE**

*Oil will flow more quickly if the filler cap/dipstick is removed from the oil tank.*

- Move drain pan beneath front of engine crankcase.
- See [Figure 1-3](#). Turn oil filter counterclockwise to remove from filter mount.
- Discard oil filter.

**Installation**

- Pour about 4 fluid ounces (U.S.) (120 ml) of fresh, clean engine oil into **new** oil filter. Allow time for oil to soak into filter element.

**NOTE**

*Partially fill oil filter before installation to minimize the time required for buildup of oil pressure when engine is first started.*

- Wipe filter gasket contact surface of oil filter mount with a clean cloth. Coat filter gasket with clean engine oil.
- Install oil filter. Hand tighten filter 1/2 to 3/4-turn after gasket contacts filter mount surface.

**CAUTION**

**Remove worm drive clamp and drain hose from rear muffler mount lug. Allow a small amount of oil to flow from hose before reconnection. This action removes air from the drain hose and prevents the possibility of oil pump cavitation. Install filler cap onto oil tank. Make sure cap is fully seated.**

- See [Figure 1-1](#). Use worm drive clamp to secure oil tank drain hose to lug on muffler mount.
- Refer to [Table 1-2](#). Always use the proper grade of oil for the lowest expected air temperature before the next regularly scheduled oil change. Pour 3 quarts (U.S.) (2.8 liters) of oil into engine oil tank minus the 4 fl. oz. (120 ml) added in step 1.
- Start engine. Verify that oil pressure signal light turns off when engine speed is 1000 RPM or above.
- Check for oil leaks at oil filter and oil tank drain hose. Turn engine off.

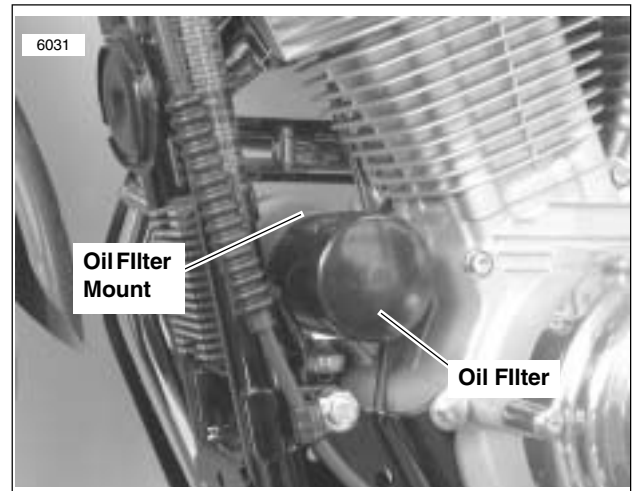

**Figure 1-3. Oil Filter**

**Table 1-2. Recommended Engine Oil Viscosity**

HARLEY-DAVIDSON TYPE	VISCOSITY	HARLEY-DAVIDSON RATING	LOWEST AMBIENT TEMPERATURE	COLD WEATHER STARTS BELOW 50° F (10° C)
HD Multigrade	SAE 10W40	HD 360	Below 40° F (4° C)	Excellent
HD Multigrade	SAE 20W50	HD 360	Above 40° F (4° C)	Good
HD Regular Heavy	SAE 50	HD 360	Above 60° F (16° C)	Poor
HD Extra Heavy	SAE 60	HD 360	Above 80° F (27° C)	Poor

**GENERAL**

**⚠ WARNING**

All batteries contain electrolyte. Electrolyte is a sulfuric acid solution that is highly corrosive and can cause severe chemical burns. Avoid contact with skin, eyes, and clothing. Avoid spillage. Always wear protective face shield, rubberized gloves and protective clothing when working with batteries. See Figure 1-4. A warning label is attached to the top of the battery. Never remove warning label from battery. Failure to read and understand all precautions contained in warning label before performing any service on batteries could result in death or serious injury. See Figure 1-5.

All AGM batteries are permanently sealed, maintenance-free, valve-regulated, lead/calcium and sulfuric acid batteries. The batteries are shipped pre-charged and ready to be put into service. Do not attempt to open these batteries for any reason.

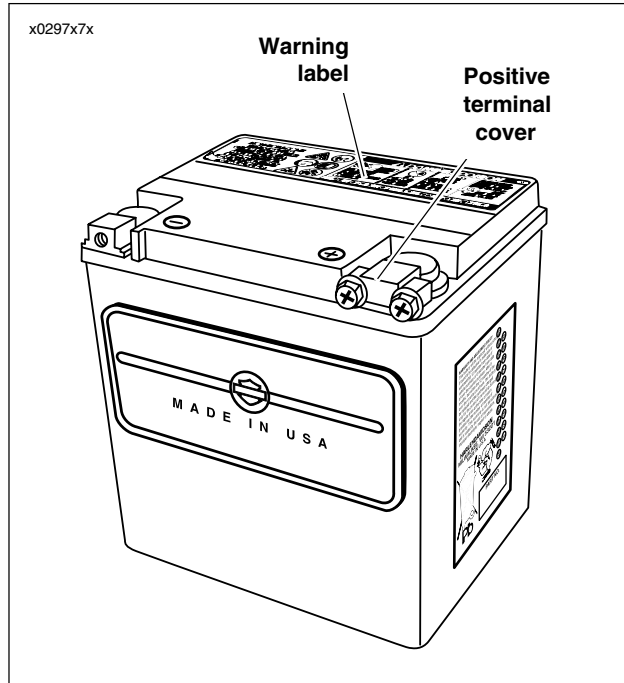

Figure 1-4. Battery

**Table 1-3. Battery Electrolyte Antidotes**

CONTACT	SOLUTION
External	Flush with water.
Internal	Drink large quantities of milk or water, followed by milk of magnesia, vegetable oil or beaten eggs. Call doctor immediately.
Eyes	Flush with water, get immediate medical attention.

x0487x7x



**Contents are Corrosive.**



**Wear Safety Glasses.**



**Contents are Explosive.**



**Keep Flames Away.**



**Read Instructions.**



**Keep Away From Children.**



Figure 1-5. Battery Warning Label

## DISCONNECTION AND REMOVAL

1. Remove motorcycle seat. See [REMOVAL](#) under [2.32 SEAT](#).
2. Remove battery strap nut and flat washer. Remove battery strap and top cover.

### WARNING

**Always disconnect the negative battery cable first. If the positive cable should contact ground with the negative cable installed, the resulting sparks may cause a battery explosion which could result in death or serious injury.**

3. Unthread bolt from terminal nut to remove negative (-) battery cable and spacer from battery terminal.
4. Unthread bolt from terminal nut to remove positive (+) battery cable and spacer from battery terminal.
5. Remove battery from battery tray.

## INSTALLATION AND CONNECTION

1. Place fully charged battery on battery tray.

### WARNING

**Always connect the positive battery cable first. If the positive cable should contact ground with the negative cable installed, the resulting sparks may cause a battery explosion which could result in death or serious injury.**

2. With negative (-) battery cable disconnected from negative (-) battery terminal, insert bolt through red wire lead, positive (+) battery cable, spacer and positive (+) battery terminal. Thread bolt into terminal nut. Tighten bolt to 40 **in lbs** (4.5 Nm).
3. Insert bolt through negative (-) battery cable, spacer and negative battery terminal. Thread the bolt into terminal nut. Tighten bolt to 40 **in lbs** (4.5 Nm).
4. Apply a light coat of petroleum jelly or corrosion retardant material to both battery terminals.
5. Position cover on top of battery. Hook end of battery strap under forward side of battery tray; draw strap over and into groove of battery cover inserting threaded stud in hole on rear side plate of battery tray. Install flat washer and strap nut.
6. Install motorcycle seat. See [INSTALLATION](#) under [2.32 SEAT](#).

### WARNING

**After installing seat, pull upward on front of seat to be sure it is locked in position. If seat is loose, it could shift during vehicle operation and startle the rider, causing loss of control which could result in death or serious injury.**

## INSPECTION

1. Battery top must be clean and dry. Dirt and electrolyte on top of the battery can cause battery to self-discharge. Clean battery top with a solution of baking soda (sodium bicarbonate) and water (5 teaspoons baking soda per quart or liter of water). When the solution stops bubbling, rinse off the battery with clean water.
2. Clean cable connectors and battery terminals using a wire brush or sandpaper. Remove any oxidation.
3. Inspect the battery screws, clamps and cables for breakage, loose connections and corrosion. Clean clamps.
4. Check the battery posts for melting or damage caused by overtightening.
5. Inspect the battery for discoloration, raised top or a warped or distorted case, which might indicate that the battery has been frozen, overheated or overcharged.
6. Inspect the battery case for cracks or leaks.

## STORAGE

### CAUTION

**Store the battery out of the reach of children. Inadequate safety precautions may result in minor or moderate injury.**

### CAUTION

**The electrolyte in a discharged battery will freeze if exposed to freezing temperatures. Freezing may crack the battery case and buckle battery plates.**

If the motorcycle will not be operated for several months, such as during the winter season, remove the battery from the motorcycle and fully charge.

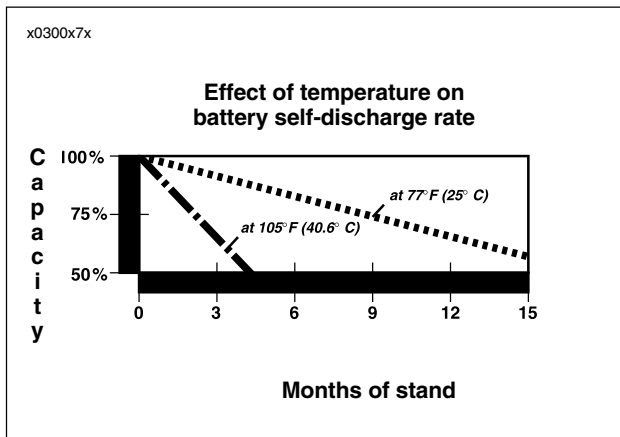

**Figure 1-6. Battery Self-Discharge Rate**

See [Figure 1-6](#). Self-discharge is a normal condition and occurs continuously at a rate that depends on the ambient temperature and the battery's state of charge. Batteries discharge at a faster rate at higher ambient temperatures. To reduce the self-discharge rate, store battery in a cool (not freezing), dry place.

Charge the battery every month if stored at temperatures below 60° F (16° C). Charge the battery more frequently if stored in a warm area above 60° F (16° C).

**NOTE**

*The BATTERY TENDER AUTOMATIC BATTERY CHARGER (Part No. 99863-93TA) may be used to maintain battery charge for extended periods of time without risk of overcharging or boiling.*

## GENERAL

The front and rear brakes are fully hydraulic disc brake systems that require little maintenance. The front brake master cylinder is an integral part of the brake hand lever assembly. The rear brake master cylinder is located on the right side of the motorcycle near the brake pedal.

## INSPECTION

Check the master cylinder reservoirs for proper fluid levels every 5000 miles (8000 km). With the reservoir in a level position, add **Harley-Davidson D.O.T. 5 SILICONE HYDRAULIC BRAKE FLUID (P/N 99902-77)** until the fluid level is 1/8 in. (3.2 mm) from the top.

Check brake pads and discs for wear every 2500 miles (4000 km). Replace brake pads if friction material is worn to 1/16 in. (1.6 mm) or less.

Minimum brake disc thickness is stamped on side of disc. Replace any brake disc that is worn beyond this limit. For disc removal and installation procedures, see FRONT or REAR WHEEL.

Maximum brake rotor lateral runout and warpage is 0.008 in. (0.2 mm) when measured near the outside diameter.

## WARNING

Clean brake system components using denatured alcohol. Do not use mineral base cleaning solvents, such as gasoline or paint thinner. Use of mineral base solvents causes deterioration of rubber parts that continues after assembly and can result in component failure and/or death or serious injury.

- Always test motorcycle brakes at low speed after servicing or bleeding system. Harley-Davidson recommends that all brake repairs be performed by a Harley-Davidson dealer or other qualified mechanic.
- ALWAYS KEEP BRAKE FLUID OUT OF THE REACH OF CHILDREN. D.O.T. 5 SILICONE HYDRAULIC BRAKE FLUID can cause eye and skin irritation and can be harmful if swallowed. In case of eye or skin contact, flush with plenty of water. Seek medical attention for eyes. If fluid is accidentally ingested, call a doctor immediately. Failure to do so could result in death or serious injury.

## TROUBLESHOOTING

Use the following troubleshooting guide to help in determining probable causes of poor brake operation.

**Table 1-4. Troubleshooting Brakes**

CONDITION	CHECK FOR	REMEDY
Excessive lever or pedal travel or spongy feel.	<ul style="list-style-type: none"> <li>● Air in system.</li> <li>● Master cylinder low on fluid.</li> </ul>	<ul style="list-style-type: none"> <li>● Bleed brake(s).</li> <li>● Fill master cylinder with approved brake fluid.</li> </ul>
Chattering sound when brake is applied.	<ul style="list-style-type: none"> <li>● Worn pads.</li> <li>● Loose mounting bolts.</li> <li>● Warped disc.</li> </ul>	<ul style="list-style-type: none"> <li>● Replace brake pads.</li> <li>● Tighten bolts.</li> <li>● Replace disc.</li> </ul>
Ineffective brake – lever or pedal travels to limit.	<ul style="list-style-type: none"> <li>● Low fluid level.</li> <li>● Piston cup not functioning.</li> </ul>	<ul style="list-style-type: none"> <li>● Fill master cylinder with approved brake fluid, and bleed system.</li> <li>● Rebuild cylinder.</li> </ul>
Ineffective brake – lever or pedal travel normal.	<ul style="list-style-type: none"> <li>● Distorted or glazed disc.</li> <li>● Distorted, glazed or contaminated brake pads.</li> </ul>	<ul style="list-style-type: none"> <li>● Replace disc.</li> <li>● Replace pads.</li> </ul>
Brake pads drag on disc – will not retract.	<ul style="list-style-type: none"> <li>● Cup, in master cylinder not uncovering relief port.</li> <li>● Rear brake pedal linkage out of adjustment.</li> </ul>	<ul style="list-style-type: none"> <li>● Inspect master cylinder.</li> <li>● Adjust linkage.</li> </ul>

## REAR BRAKE PEDAL HEIGHT

### Brake Pedal

See [Figure 1-7](#). and [Figure 1-8](#). Loosen locknut (1) on rod end (2). With motorcycle on level surface, adjust push rod (3) so that brake pedal is at a 45 degree angle from floor (883/1200C; see [Figure 1-9](#).) or parallel with floor (all other models; see [Figure 1-10](#).). Tighten locknut.

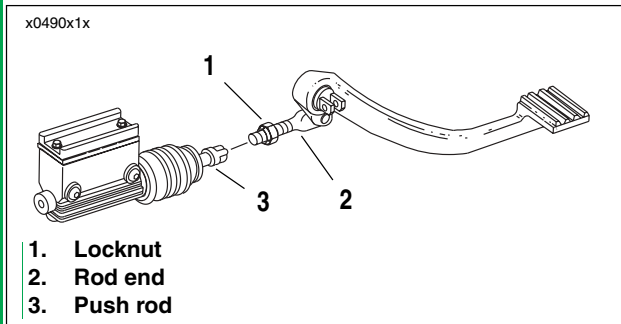

**Figure 1-7. Rear Brake Pedal Adjustment:  
All Except 883/1200 Custom**

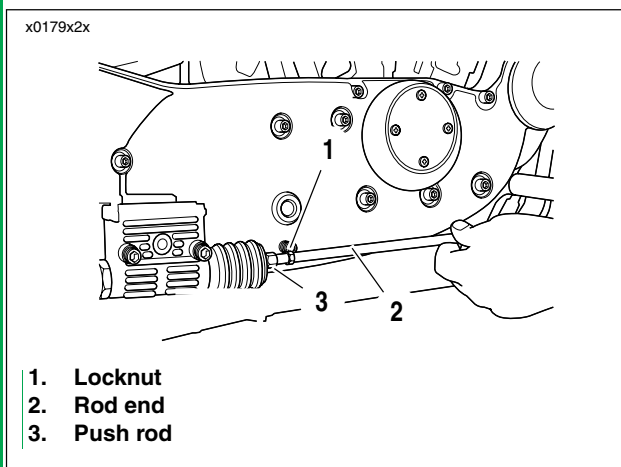

**Figure 1-8. Rear Brake Pedal Adjustment:  
883/1200 Custom**

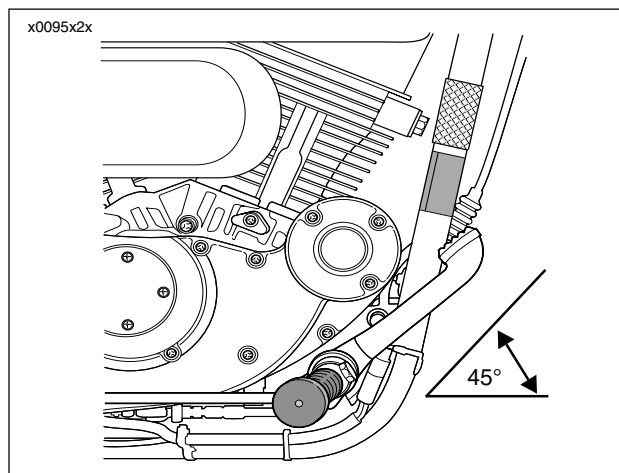

**Figure 1-9. Rear Brake Pedal Adjustment:  
883/1200 Custom**

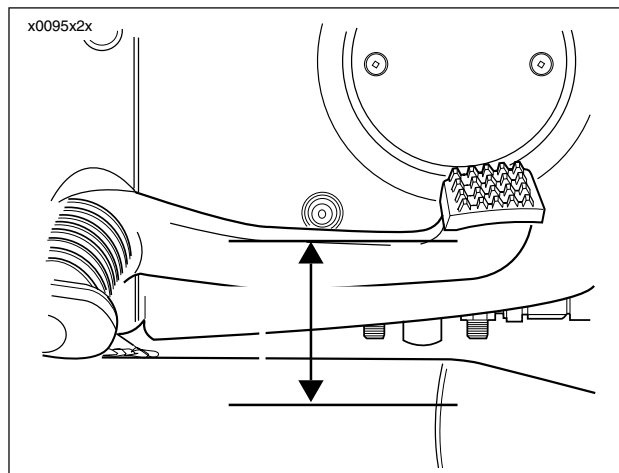

**Figure 1-10. Rear Brake Pedal Height:  
All except 883/1200 Custom**

## GENERAL

See [Figure 1-11](#). Bleed the hydraulic brake system anytime a hydraulic brake line, brake master cylinder or brake caliper has been opened, or whenever brake lever/pedal operation feels “spongy.” Bleeding evacuates air from the system leaving only incompressible hydraulic fluid.

### ⚠ WARNING

**ALWAYS KEEP BRAKE FLUID OUT OF THE REACH OF CHILDREN. D.O.T. 5 SILICONE HYDRAULIC BRAKE FLUID can cause eye and skin irritation and can be harmful if swallowed. In case of eye or skin contact, flush with plenty of water. Seek medical attention for eyes. If fluid is accidentally ingested, call a doctor immediately. Failure to do so could result in death or serious injury.**

## PROCEDURE

### NOTE

*Hydraulic brake fluid bladder-type pressure equipment can be used to fill brake master cylinders through the bleeder valve. Remove master cylinder reservoir cover so that system cannot pressurize. Do not use pressure bleeding equipment when the hydraulic system is sealed with master cylinder reservoir cover and gasket in place.*

1. Install end of a length of plastic tubing over caliper bleeder valve. Place free end of tube in a clean container. Stand motorcycle upright.
2. Add Harley-Davidson D.O.T. 5 SILICONE HYDRAULIC BRAKE FLUID to master cylinder reservoir until the fluid level is 1/8 in. (3.2 mm) from the top. Do not reuse brake fluid.
3. Depress and hold brake lever/pedal to build up hydraulic pressure.
4. Open bleeder valve about 1/2-turn. Brake fluid will flow from bleeder valve through tubing. Close bleeder valve when brake lever/pedal has moved 1/2 to 3/4 of its full range of travel. Allow brake lever/pedal to return slowly to its released position.
5. Repeat Steps 2-4 until all air bubbles are purged.
6. Final tighten bleeder valve to 80-100 in-lbs (9.0-11.3 Nm). Install bleeder cap. Add brake fluid to master cylinder reservoir until fluid level is about 1/8 in. (3.2 mm) from the top. Do not reuse brake fluid. Final tighten master cylinder reservoir cover screws to 6-8 in-lbs (0.7-0.9 Nm).

### ⚠ WARNING

**Always test motorcycle brakes at low speed after completing repairs or bleeding the system. Improper or unsafe brake operation could result in death or serious injury.**

7. Test ride motorcycle. Repeat the above bleeding procedure if brakes feel spongy.

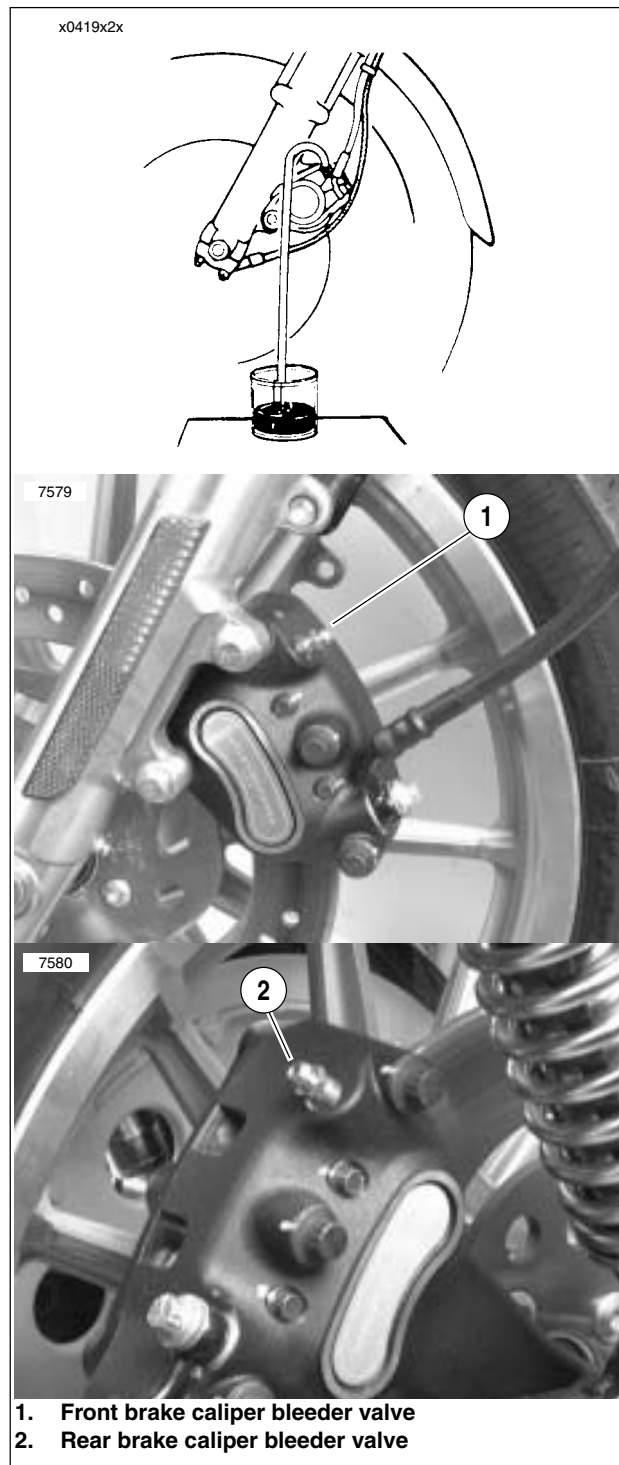

1. Front brake caliper bleeder valve
2. Rear brake caliper bleeder valve

Figure 1-11. Bleeding Hydraulic System

## INSPECTION

Check brake pads and discs:

- At every scheduled service interval.
- Whenever the components are removed during service procedures.

### Brake Pads

#### WARNING

Always replace brake pads in complete sets for correct brake operation. Never replace just one brake pad. Failure to install brake pads as a set could result in death or serious injury.

See [Figure 1-12](#). Replace brake pads (3) if brake pad friction material on either the front or rear caliper is worn to 0.04 in. (1.02 mm) or less above the backing plate (4). Always replace both pads in a caliper as a set. See [BRAKE PAD REPLACEMENT](#) below.

When checking the brake pads and discs, inspect the brake hoses for correct routing and any signs of damage.

### Brake Disc Thickness

The minimum brake disc (2) thickness is stamped on the side of the disc. Replace disc if badly scored.

### Brake Disc Lateral Runout and Warp

Maximum brake disc lateral runout and warp is 0.008 in. (0.2 mm) when measured near the outside diameter.

## BRAKE PAD REPLACEMENT

### Rear Brake Caliper

1. Remove the rear master cylinder reservoir cap. As the pistons are pushed back into the caliper, fluid level may rise more than 1/8 in. (3.2 mm). You may have to remove fluid to allow for this.
2. See [Figure 1-13](#). Loosen, but do not remove, both pad pins (12 pt/0.25 in.).
3. Pry the inside pad back. Use steady pressure to prevent scoring the brake disc. Pry between the pad and the brake disc in order to push the caliper pistons back into their bores.

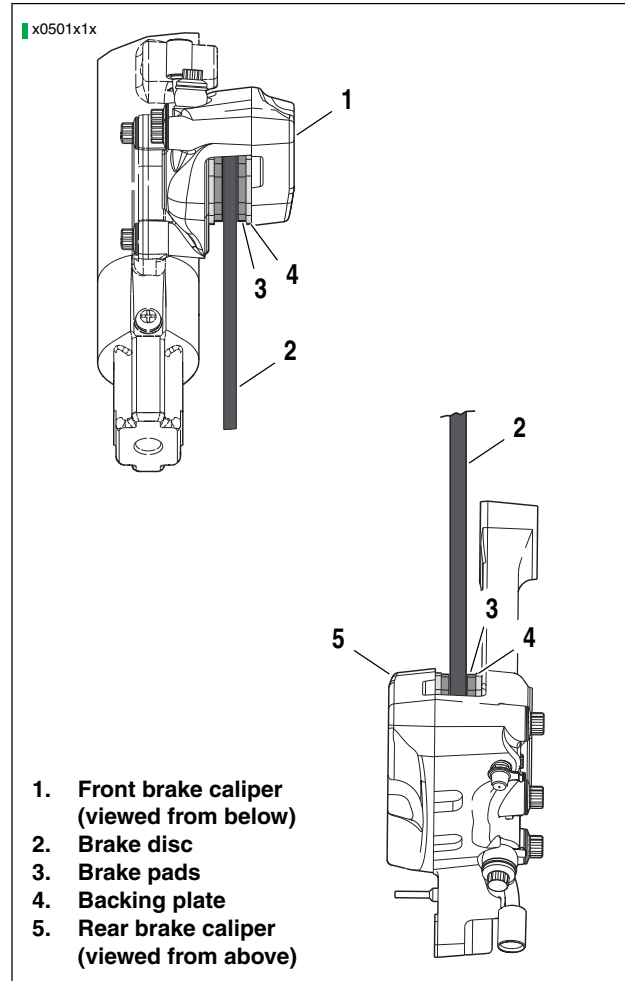

Figure 1-12. Brake Pad Inspection

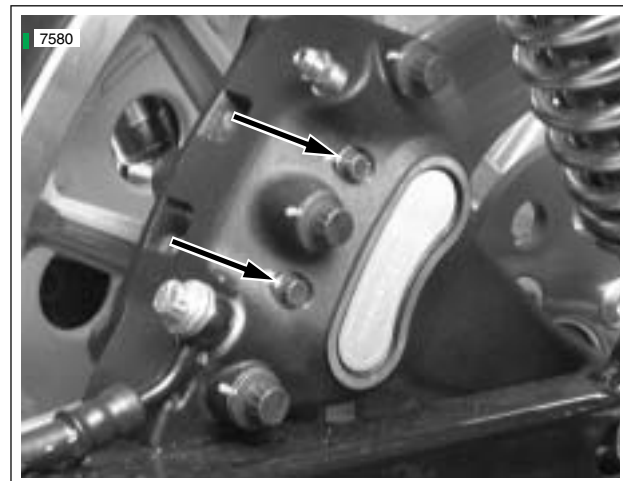

Figure 1-13. Pad Pins (12 pt/0.25 in.) (Rear Caliper Shown)

**CAUTION**

**Do not completely pull pad pins from caliper during the next step. Completely removing pad pins at this time will cause difficulty during assembly.**

4. Once the pistons have been fully retracted into their bores, pull pad pins part way until the inside pads drop free. Note the pad's original orientation for replacement purposes.

**NOTE**

See [Figure 1-14](#). The front left, front right (not present on all vehicles) and rear brake calipers use the same exact brake pad set. Install pad with two tabs (1) on the inboard side of the rear caliper.

5. Install **new** inside brake pad using the same orientation as the pad previously removed. Curved portion of pad must face rear of motorcycle.
6. Install pad pins until the pins snap into place with an audible click. Do not fully tighten at this time.
7. Pump brake pedal lever to move inside pistons out until they contact inside brake pads.
8. Pry the outside pad back. Pry between the pad and the brake disc in order to push the caliper pistons back into their bores.
9. Verify that inside pads are captured between brake disc and pistons. Completely remove pad pins to free outside brake pad. Note the pad's original orientation for replacement purposes.
10. Inspect pad pins for grooving and wear. Measure the pad pin diameter in an unworn area, and then in the area of any grooving or wear. If wear is more than 0.015 in. (0.38 mm), replace both pins.
11. Install **new** outside brake pad using the same orientation as the pad previously removed. If the inside pad moved during the previous step, reinstall. Curved portion of pad must face rear of motorcycle.
12. Install both pad pins through holes in inner and outer brake pads. Tighten to 180-200 **in-lbs** (20.3-22.6 Nm).

**WARNING**

**Whenever new pads are installed, BEFORE moving motorcycle, you must pump brake fluid until the pistons push the pads against the brake disc. If you don't pump fluid pressure up again, the brakes will not be available to stop the motorcycle which could result in death or serious injury.**

13. Pump brake pedal to move pistons out until they contact both brake pads. Verify piston location against pads.
14. Check brake fluid level in master cylinder. Fill to proper level if necessary using D.O.T. 5 SILICONE BRAKE FLUID. Install master cylinder reservoir cap. Tighten reservoir cap screws to 6-8 **in-lbs** (0.7-0.9 Nm).

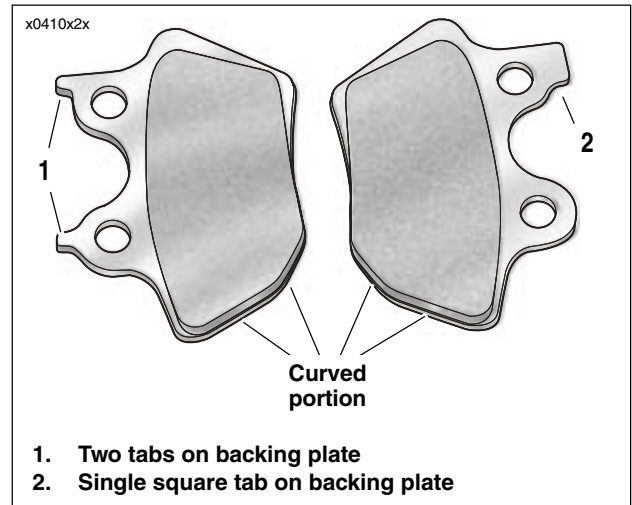

**Figure 1-14. Brake Pad Orientation**

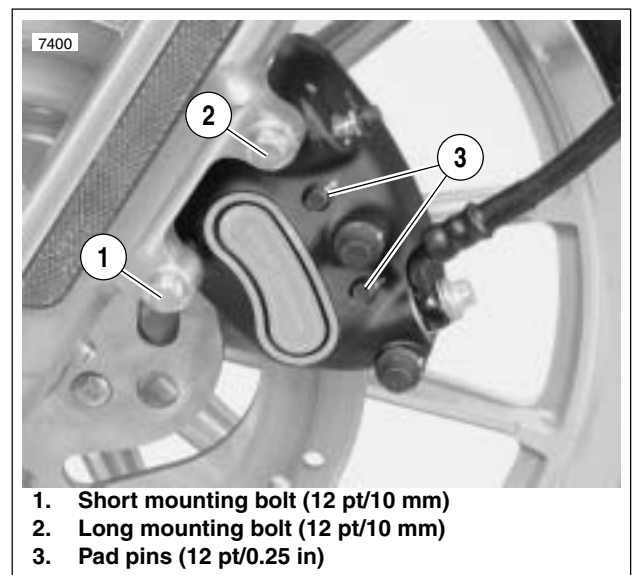

**Figure 1-15. Front Brake Caliper (Left Side Shown)**

**WARNING**

**After completing repairs or bleeding the system, always test motorcycle brakes at low speed. If brakes are not operating properly or braking efficiency is poor, testing at high speeds could result in death or serious injury.**

15. Test brake system.
  - a. Turn ignition switch ON. Pump brake pedal to verify operation of the brake lamp.
  - b. Test ride the motorcycle. If the brakes feel spongy, bleed the system. See [1.7 BLEEDING HYDRAULIC BRAKE SYSTEM](#).

**NOTE**

*Avoid making hard stops for the first 100 miles (160 km). This allows the **new** pads to become conditioned to the brake discs.*

## Front Brake Caliper

1. Remove the front master cylinder reservoir cap. As the pistons are pushed back into the caliper, fluid level may rise more than 1/8 in. (3.2 mm). You may have to remove fluid to allow for this.
2. See [Figure 1-15](#). Loosen, but do not remove, both pad pins (3) (12 pt/0.25 in.).
3. Remove both caliper mounting bolts (1, 2) (metric). Detach caliper from front forks and brake disc.
4. Pry the pads back to force all four caliper pistons into their bores.
5. With the pistons retracted, remove the pad pins and brake pads.
6. Inspect pad pins for grooving and wear. Measure the pad pin diameter in an unworn area, and then in the area of any grooving or wear. If wear is more than 0.015 in. (0.38 mm), replace both pins.

### NOTE

See [Figure 1-14](#). The front left, front right (not present on all vehicles) and rear brake calipers use the same exact brake pad set.

- On the right side of the vehicle, the pad with two tabs (1) installs on the inboard side of the caliper.
  - On the left side of the vehicle, the pad with two tabs (1), installs on the outboard side of the caliper.
7. Install **new** pads into caliper. Curved portion of pad must face rear of motorcycle.
  8. Loosely install the pad pins until you hear an audible click.
  9. Attach caliper to front fork.
    - a. See [Figure 1-16](#). On models with dual front calipers, check alignment of brake discs to calipers. Loosen axle pinch bolt nuts. Tighten axle nut to proper torque. Insert a 7/16 in. drill bit (1) through hole in front axle as far as it will go. Contact point (2) must have edge of drill bit touching the edge of fork leg. See [2.7 WHEEL INSTALLATION](#).
    - b. See [Figure 1-15](#). Place caliper over brake disc with bleeder valve facing upwards.
    - c. Loosely install long mounting bolt (2) (12 pt/10 mm) into top hole on fork leg.
    - d. Install short mounting bolt (1) (12 pt/10 mm) into bottom hole on fork leg. Tighten bottom mounting bolt to 28-38 ft-lbs (38.51.5 Nm).
    - e. Final tighten the top mounting bolt to 28-38 ft-lbs (38.51.5 Nm).
    - f. Final tighten both pad pins to 180-200 **in-lbs** (20.3-22.6 Nm).
    - g. On models with dual front calipers, tighten pinch bolt nuts while holding slider against 7/16 drill bit if necessary. See [2.7 WHEEL INSTALLATION](#). Remove drill bit.

### WARNING

Whenever new pads are installed, **BEFORE** moving motorcycle, you must pump brake fluid until the pistons push the pads against the brake disc. If you don't pump fluid pressure up again, the brakes will not be available to stop the motorcycle which could result in death or serious injury.

10. Pump brake hand lever to move pistons out until they contact both brake pads. Verify piston location against pads. If the front wheel is off the ground, rotate wheel to check for excessive brake pad drag.
11. Check brake fluid level in master cylinder. Fill to proper level if necessary using D.O.T. 5 SILICONE BRAKE FLUID. Install master cylinder reservoir cap. Tighten reservoir cap screws to 6-8 **in-lbs** (0.7-0.9 Nm).

### WARNING

After completing repairs or bleeding the system, always test motorcycle brakes at low speed. If brakes are not operating properly or braking efficiency is poor, testing at high speeds could result in death or serious injury.

12. Test brake system.
  - a. Turn ignition switch ON. Pump brake hand lever to verify operation of the brake lamp.
  - b. Test ride the motorcycle. If the brakes feel spongy, bleed the system. See [1.7 BLEEDING HYDRAULIC BRAKE SYSTEM](#).

### NOTE

Avoid making hard stops for the first 100 miles (160 km). This allows the **new** pads to become conditioned to the brake discs.

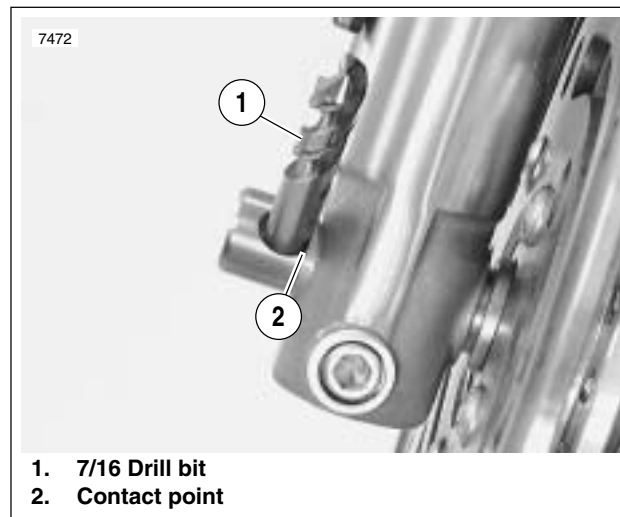

1. 7/16 Drill bit
2. Contact point

Figure 1-16. Dual Caliper Alignment

## TIRES

**⚠ WARNING**

For your own personal safety, tires, rims and air valves must be correctly matched to wheel rims. See your Harley-Davidson dealer. Mismatching tires, tubes, rims and air valves may result in damage to the tire bead during mounting or may allow the tire to slip on the rim, possibly causing tire failure and resulting in death or serious injury.

- In addition, using tires other than those specified may adversely affect motorcycle handling.
- Tubeless tires fitted with the correct size inner tubes may be used on all Harley-Davidson laced (wire spoked) wheels. Protective rubber rim strips must be used with tubeless tires (fitted with correct size inner tubes) when mounted on laced (wire spoked) wheels.
- Inner tubes must not be used in radial tires and radial tires must not be used on laced (wire spoked) wheels.
- Tubeless tires are used on all Harley-Davidson cast and disc wheels.
- Tire sizes are molded on the tire sidewall. Inner tube sizes are printed on the tube.

Check tire pressure and tread:

- As part of the pre-ride inspection.
  - At every scheduled service interval.
1. Inspect each tire for punctures, cuts, and breaks.
  2. Inspect each tire for wear. Replace tires before they reach the tread wear indicator bars.

**NOTE**

Missing indicator wear bars represent less than 1/32 in. (0.8 mm) tread pattern depth remaining.

**⚠ WARNING**

Do not exceed the maximum inflation pressure listed on tire sidewall. Overinflating could lead to tire failure which could result in death or serious injury.

3. Check for proper front and rear tire pressures when tires are cold. Compare results against [Table 1-5](#).

## TIRE REPLACEMENT

See [Figure 1-17](#). Tire wear indicator bars appear on tire tread surfaces when 1/32 inch (0.8 mm) or less tire tread remains. Arrows on tire sidewalls pinpoint location of wear bar indicators. Always remove tires from service before they reach the tread wear indicator bars, indicating 1/32 inch (0.8 mm) tread pattern depth remaining.

New tires are needed if any of the following conditions exist.

- Tire wear indicator bars become visible on the tread surfaces.
- Tire cords or fabric become visible through cracked sidewalls, snags or deep cuts.
- A bump, bulge or split in the tire is found.
- Puncture, cut or other damage to the tire that cannot be repaired.

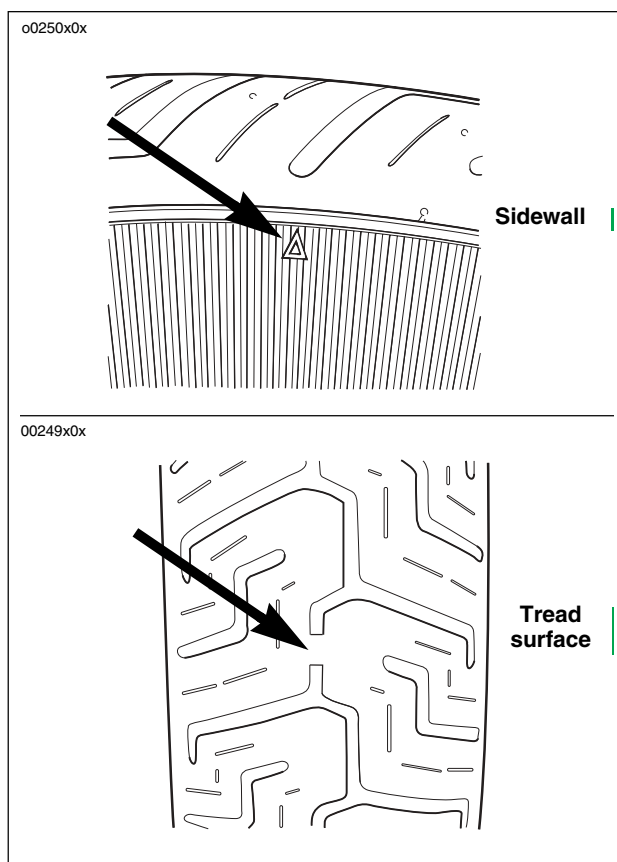

Figure 1-17. Tread Wear Indicators

Table 1-5. Tire Pressures

ALL MODELS DUNLOP TIRES ONLY	SOLO RIDER		RIDER & ONE PASSENGER	
	PSI	kPA	PSI	kPA
Front	30	207	30	207
Rear	36	248	40	276

## WHEEL BEARINGS

---

Service wheel bearings:

- Inspect any time the wheels are removed.
- Replace when bearings exceed end play service wear limit of 0.002 in. (0.051 mm).

Check wheel bearings and axle spacers for wear and corrosion. Excessive play or roughness indicates worn bearings. Replace bearings in sets only. See [2.6 SEALED WHEEL BEARINGS](#).

## WHEEL SPOKES

---

Inspect vehicles with wheel spokes:

- At the 5000 mile (8000 km) service interval.
  - At every 5000 mile (8000 km) service interval thereafter.
1. Raise motorcycle wheel off the ground.

### CAUTION

**If nipples require more than one full turn to tighten spoke, remove tire to check that spoke is not protruding far enough to damage tube.**

2. Lightly tap each spoke with a spoke wrench. Loose spokes will sound dull and must be tightened. Tighten spokes to 40-50 **in-lbs** (4.5-5.6 Nm). If more than a few spokes are loose, true the entire wheel following procedure under [2.11 TRUING LACED WHEELS](#).

## INSPECTION

1. See [Figure 1-18](#). Check the primary chain for correct tension by measuring its vertical free play through the primary chain inspection cover (1) opening located near the top of the primary cover (2).

## NOTE

See [Figure 1-19](#). A properly adjusted primary chain should have the specified vertical free play in its upper strand.

2. Be sure the measurement is taken midway between engine and clutch sprockets with sprockets rotated to the tightest chain position.

## NOTE

Always measure the vertical free play with the sprockets rotated to several different positions. The tightest measurement observed must be within specifications shown in [Figure 1-19](#).

The initial primary chain vertical free play specification used at the Harley-Davidson assembly plant is 1/4 -1/2 in. (6.3-12.7 mm) with a cold engine. The 1/4 in. (6.3 mm) minimum is only allowed at the absolute tightest point in the drive, as measured with specialized factory equipment. If a chain has less than 1/4 in. vertical free play (with a cold engine), adjust free play to the "field" specification of 3/8-1/2 in. (9.5-12.7 mm). The looser specification will avoid overtightening, which might otherwise occur during adjustment using "non-factory" equipment and methods.

An opening between the primary drive and transmission compartments allows the same lubricant supply to lubricate moving parts in both compartments. For complete lubrication service on the primary chain, see [1.12 TRANSMISSION LUBRICANT](#).

Since the primary chain runs in lubricant, little service will be required other than checking lubricant level and chain tension. If, through hard usage, the primary chain does become worn, it must be replaced. Remove and install the chain following the procedure under [6.2 PRIMARY CHAIN](#).

## ADJUSTMENT

**WARNING**

To avoid accidental start-up of vehicle and possible personal injury, disconnect the battery cables before proceeding. Always disconnect the negative cable first. If the positive cable should contact ground with the negative cable installed, the resulting sparks may cause a battery explosion which could result in death or serious injury.

See [Figure 1-18](#). The primary chain can be adjusted without removing the primary cover (2). Proceed as follows:

1. Remove the two hex socket screws which secure primary chain inspection cover (1).
2. Rotate sprockets to find tightest point on primary chain.

3. Loosen locknut (6). Turn chain adjuster screw (5) clockwise (inward) to reduce free play or counterclockwise (outward) to increase free play. Vertical free play must fall within the limits specified in [Figure 1-19](#).

## NOTE

If vertical free play cannot be set within the limits specified in [Figure 1-19](#), then primary chain and/or chain adjuster are worn beyond adjustment limits. Replace parts as necessary.

4. See [Figure 1-18](#). When tension is set correctly, tighten locknut (6) to 20-25 ft-lbs (27-34 Nm).
5. Install primary chain inspection cover (1). Tighten hex socket screws to 40-60 in-lbs (4.5-6.8 Nm).

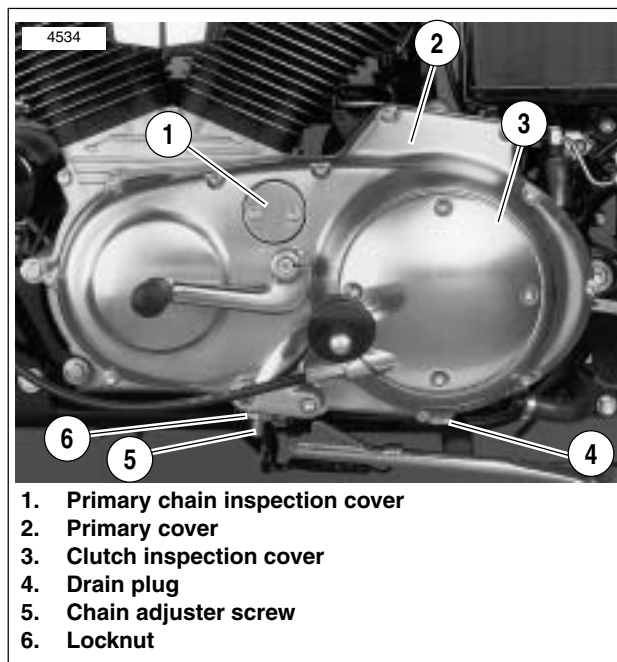

Figure 1-18. Primary Cover

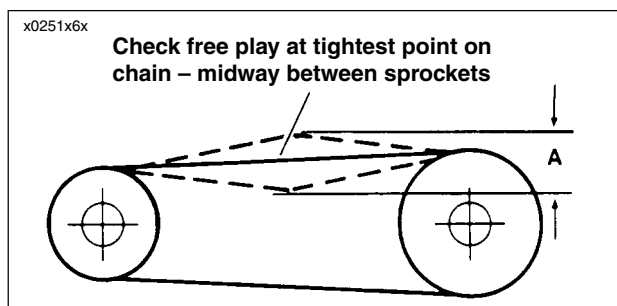

Figure 1-19. Primary Chain Vertical Free Play

Table 1-6. Primary Chain Specifications

ENGINE	MEASUREMENT "A"	
Cold	3/8-1/2 in.	9.5-12.7 mm
Hot	1/4-3/8 in.	6.3-9.5 mm

## ADJUSTMENT

All models feature a primary cover and a quick-release clutch cable to simplify both clutch service and adjustment.

1. See [Figure 1-20](#). Slide rubber boot off cable adjuster.
2. Holding cable adjuster with 1/2 inch wrench, loosen jam nut using a 9/16 inch wrench. Back jam nut away from cable adjuster. Move adjuster toward jam nut to introduce a large amount of free play at hand lever.
3. Remove locknut and bolt to free left side footrest from footrest support. Remove footrest and spring washer.
4. See [Figure 1-21](#). Using T-27 TORX driver, remove four TORX screws with washers to remove clutch inspection cover. Exercise caution to avoid damaging or dislodging quad ring in primary cover.

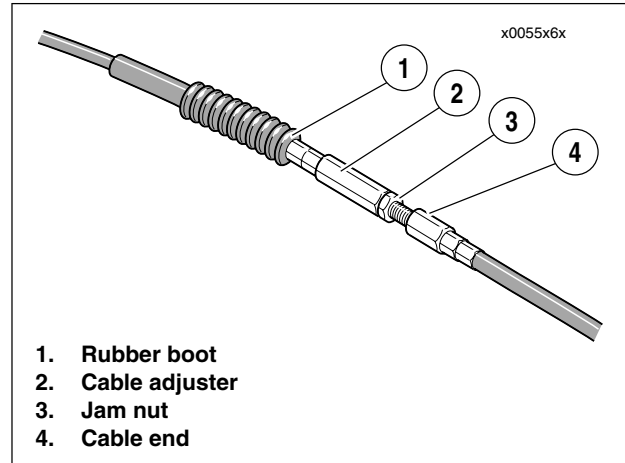

1. Rubber boot
2. Cable adjuster
3. Jam nut
4. Cable end

Figure 1-20. Clutch Cable Adjuster Mechanism

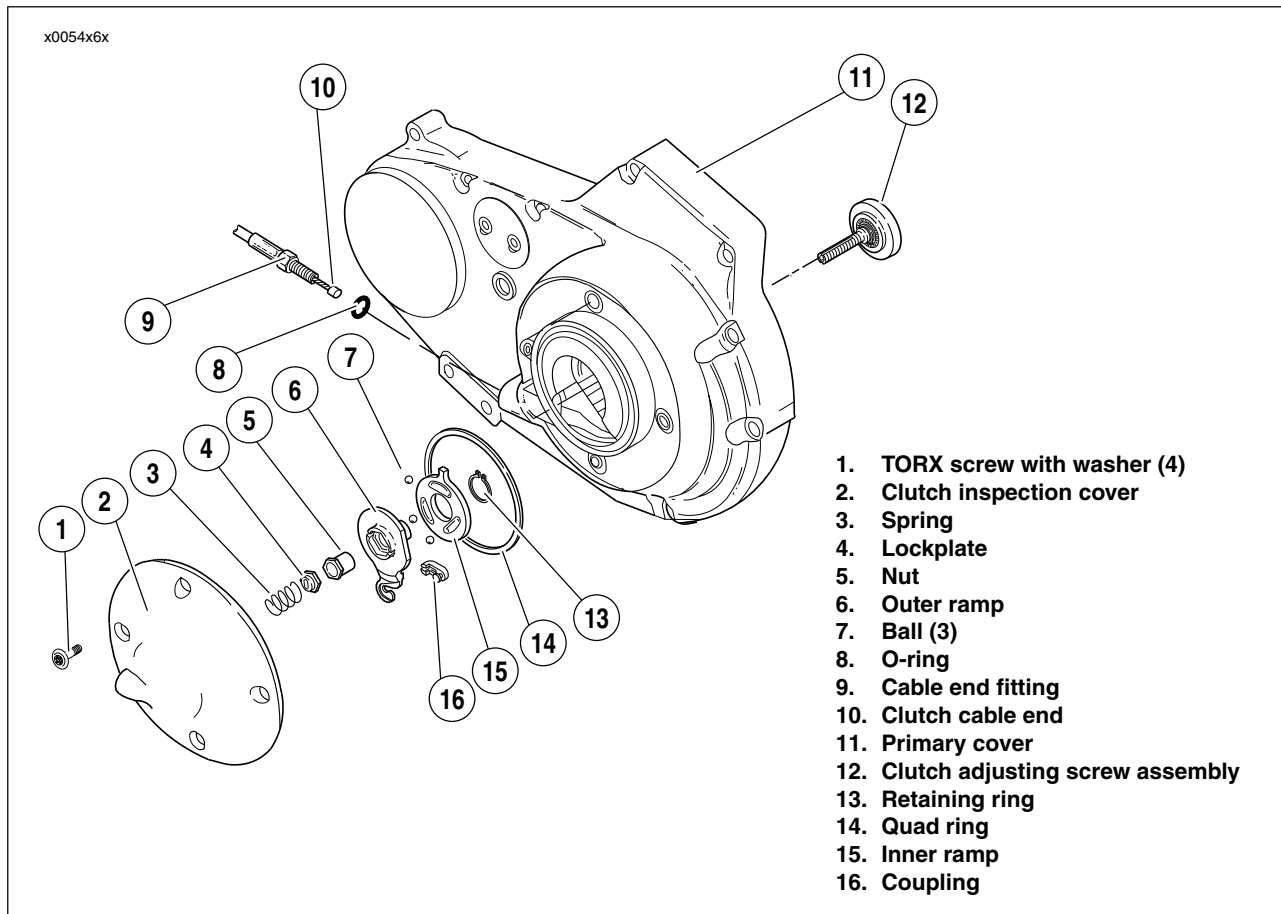

1. TORX screw with washer (4)
2. Clutch inspection cover
3. Spring
4. Lockplate
5. Nut
6. Outer ramp
7. Ball (3)
8. O-ring
9. Cable end fitting
10. Clutch cable end
11. Primary cover
12. Clutch adjusting screw assembly
13. Retaining ring
14. Quad ring
15. Inner ramp
16. Coupling

Figure 1-21. Clutch Release Mechanism

5. Slide spring with attached hex lockplate from flats of adjusting screw. Turn adjusting screw counterclockwise until resistance is felt. Back off adjusting screw 1/4 turn.
6. Slide spring with hex lockplate onto flats of adjusting screw. If necessary, turn adjusting screw clockwise slightly so that lockplate slides onto flats while also fitting within recess of outer ramp.
7. Verify that quad ring is fully seated in groove of primary cover. Using T-27 TORX driver, install four TORX screws with washers to secure clutch inspection cover. Tighten screws in a crosswise pattern to 84-108 **in-lbs** (9-12 Nm).
8. See [Figure 1-20](#). Turn cable adjuster clockwise away from jam nut until slack is eliminated. Pull clutch cable ferrule away from clutch lever bracket to check free play. Turn cable adjuster as necessary to obtain 1/16 to 1/8 inch free play between end of cable ferrule and clutch lever bracket, as shown in [Figure 1-22](#).

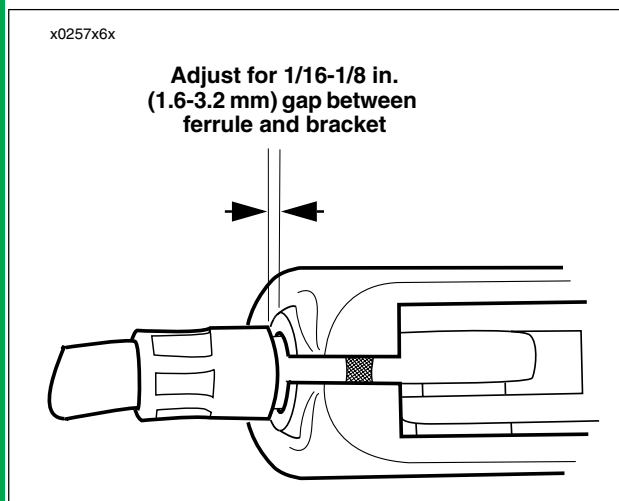

**Figure 1-22. Adjusting Clutch Free Play**

9. Hold adjuster with 1/2 inch wrench. Using 9/16 inch wrench, tighten jam nut against cable adjuster. Cover cable adjuster mechanism with rubber boot.
10. Position spring washer over lower inside hole of left footrest support. The concave side of the spring washer should face the support flange. Align holes in footrest with those in support and spring washer. Install bolt and locknut. Tighten locknut to 96-192 **in-lbs** (11-22 Nm).

## CHANGING LUBRICANT

Drain transmission and refill to correct level with fresh, clean lubricant at least once each year or every 5000 miles (8000 km), whichever comes first. For best results, drain lubricant while hot. Proceed as follows:

1. On level surface, stand vehicle upright (not leaning on jiffy stand) to prevent chaincase lubricant from draining out of clutch cover opening when refilled.
2. See [Figure 1-23](#). Position a suitable container under transmission lubricant drain plug (1). Remove drain plug and drain lubricant.

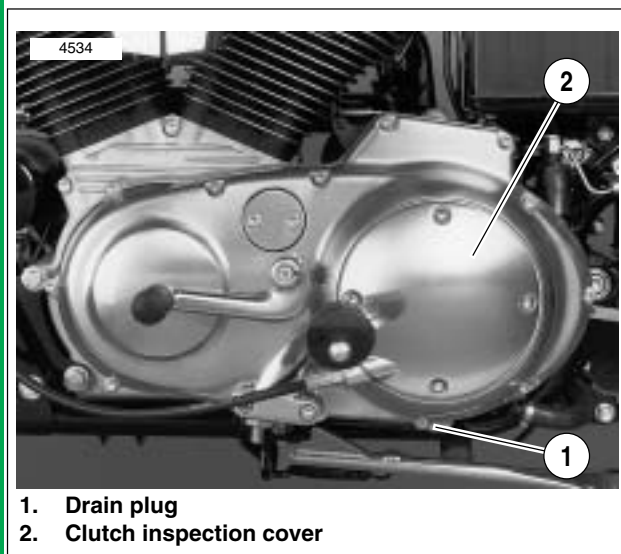

Figure 1-23. Primary Cover

3. Remove foreign material from magnetic drain plug. Reinstall plug and tighten to 14-21 ft-lbs (19-28 Nm).
4. Using a T-27 TORX driver, remove screws with washers from clutch inspection cover (2). Remove clutch inspection cover from primary cover. Exercise caution to avoid damaging or dislodging quad ring in primary cover.

### CAUTION

**Do not overfill the primary chaincase with lubricant. Overfilling may cause rough clutch engagement, incomplete disengagement, clutch drag and/or difficulty in finding neutral at engine idle.**

5. Add 32 fluid ounces (946 ml) of Harley-Davidson Sport-Trans Fluid (Part No. 98854-96 quart size; Part No. 98855-96 gallon size) through clutch inspection cover opening.
6. See [Figure 1-24](#). Verify that lubricant level (5) is even with bottom of clutch diaphragm spring (1).
7. Install clutch inspection cover on primary cover using T-27 TORX screws with washers. Tighten screws in a crosswise pattern to 84-108 **in-lbs** (9-12 Nm).

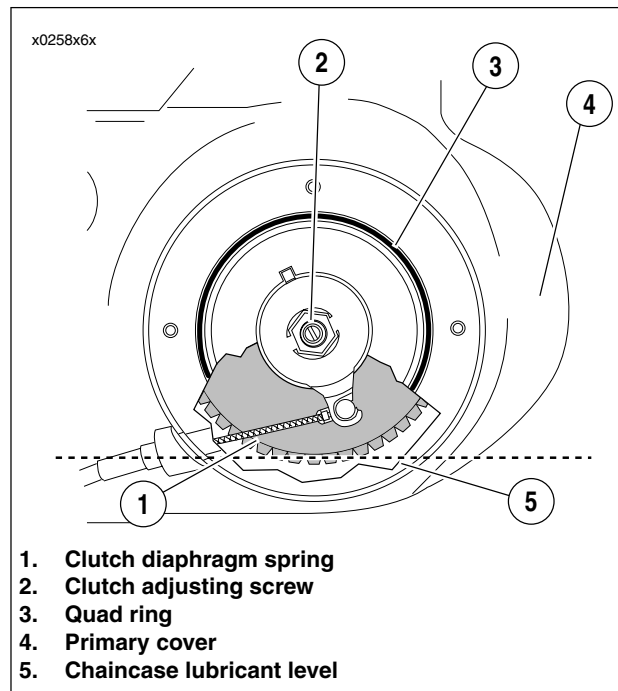

Figure 1-24. Chaincase Lubricant Level

## INSPECTION

PART NO.	SPECIALTY TOOL
HD-35381	Belt tension gauge

Check rear belt deflection:

- As part of the pre-ride inspection.
- At every scheduled service interval.

When checking belt deflection:

- Set belt tension at tightest point in belt.
  - Measure belt deflection with motorcycle cold and the approximate weight of the owner on motorcycle.
1. See [Figure 1-25](#). Obtain BELT TENSION GAUGE (HD-35381).

## NOTE

Customers may purchase gauge from an authorized Harley-Davidson dealer.

2. To use the belt tension gauge:
  - a. Slide O-ring (4) toward 0 ft-lbs (0 kg) mark (3).
  - b. Fit belt cradle (2) against bottom of drive belt approximately half-way between drive pulleys.
  - c. Press upward on knob (6) until O-ring slides down to 10 ft-lbs (4.5 kg) mark (5).
  - d. See [Figure 1-26](#). Measure belt deflection as viewed through deflection viewing window (2) while holding gauge steady. Deflection graduations (3) are 1/8 in. (3.2 mm) apart.
3. See [Figure 1-27](#). Check belt deflection at position "A," midway between transmission sprocket and rear wheel sprocket. Apply 10 lbs (4.5 Kg) of upward force on lower span of rear belt using BELT TENSION GAUGE (Part No. HD-35381).

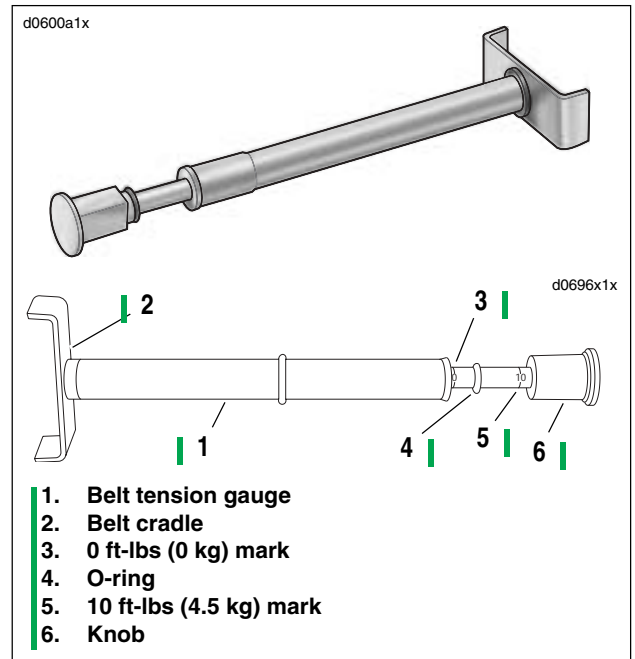
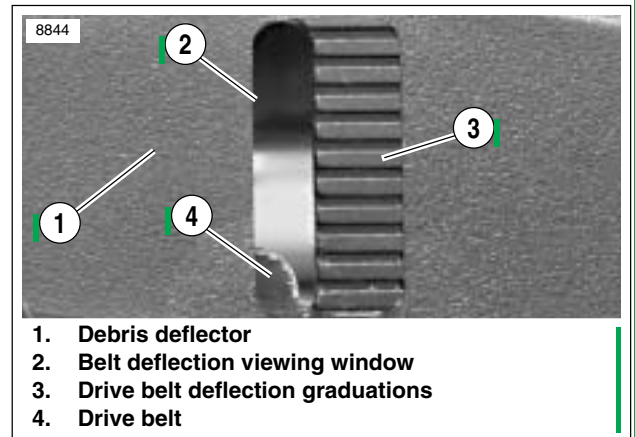

Figure 1-25. Belt Tension Gauge (Part No. HD-35381)



1. Debris deflector
2. Belt deflection viewing window
3. Drive belt deflection graduations
4. Drive belt

Figure 1-26. Belt Deflection Window

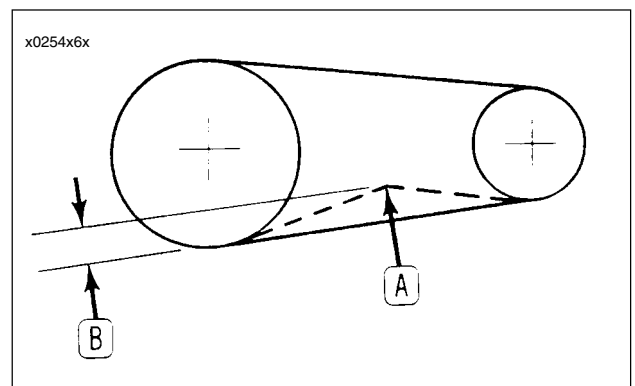

Figure 1-27. Secondary Drive Belt Deflection



**Suggest:**

**For more complete manuals. Please go to the home page.**

**<https://www.ebooklibonline.com>**

**If the above button click is invalid. Please download this document first, and then click the above link to download the complete manual.**

**Thank you so much for reading**

4. Measure belt deflection "B" several times, each time with belt moved (by rotating rear wheel) to a different position on sprockets. With sprockets rotated to the tightest belt position, belt deflection "B" should be as shown in Table 1-7.

**NOTE**

Do not rely on "feel" for the proper deflection as this typically results in belts which are under tensioned. Always use H-D BELT TENSION GAUGE (Part No. HD-35381) to determine the 10 lb. (4.5 Kg) deflection force. Loose belts will fail due to "ratcheting" (jumping a tooth) with resultant tensile cord crimping and breakage.

**Table 1-7. Belt Deflection**

MODEL	DEFLECTION
<b>883 Hugger</b> <b>883 Custom</b>	1/4 in. to 5/16 in. (6.35-7.93 mm) with 10 lbs (4.5 Kg) of force.
<b>883/1200 Standard</b> <b>1200 Sport</b>	5/16 in. to 3/8 in. (7.93-9.52 mm) with 10 lbs (4.5 Kg) of force.

**ADJUSTMENT**

1. See Figure 1-27. Determine belt deflection in manner specified in **INSPECTION**. If belt deflection "B" is not correct, adjust per the following procedures.
2. See Figure 1-28. Remove cotter pin (1) and loosen rear axle nut (4). Turn axle adjuster nuts 2) (on each side of rear fork) clockwise to decrease belt deflection (increase tension), or counterclockwise to increase belt deflection (decrease tension). Turn each adjuster nut exactly the same number of turns in order to maintain alignment of rear wheel.

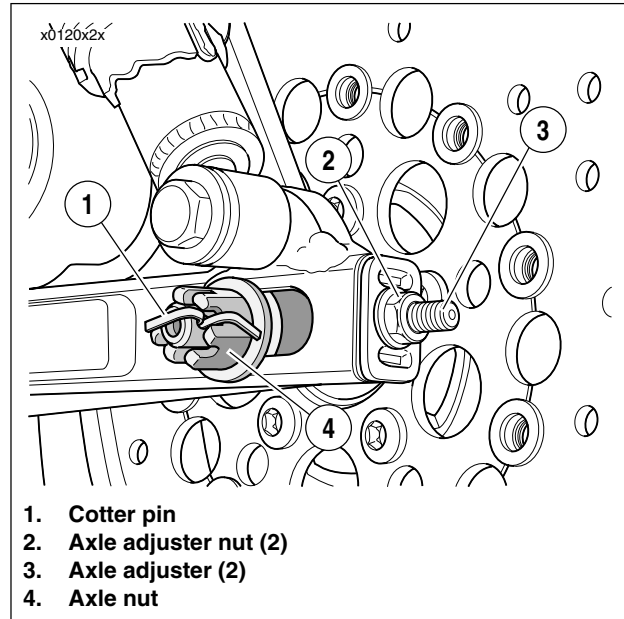
**Figure 1-28. Secondary Drive Belt Adjustment**

3. Check rear wheel alignment. Wheel must be centered between swing arm. See [Wheel Alignment](#) under 2.13 TIRES, INSTALLATION.

**WARNING**

Do not exceed 65 ft-lbs (88 Nm) when tightening the axle nut. Exceeding 65 ft-lbs (88 Nm) may cause the wheel bearings to seize during operation, which could result in death or serious injury.

4. After belt deflection is properly adjusted, tighten axle nut (2) to 60-65 ft-lbs (81-88 Nm). Install cotter pin (1).

## GENERAL

Inspect the drive belt and rear sprocket:

- At the 1000 mile (1600 km) service interval.
- At every 5000 mile (8000 km) service interval thereafter.

### NOTE

When a drive belt is replaced for any reason other than stone damage, it is recommended that the transmission and rear sprockets also be replaced to increase the longevity of the new drive belt. In the case of stone damage, inspect sprockets for damage and replace as required.

## CLEANING

Keep dirt, grease, oil, and debris off the belt and sprockets. Clean the belt with a rag slightly dampened with light cleaning agent.

## INSPECTION

### Sprockets

1. See [Figure 1-29](#). Inspect each tooth of rear sprocket for:
  - major tooth damage
  - large chrome chips with sharp edges
  - gouges caused by hard objects
  - excessive loss of chrome plating (see Step 3).
2. If chrome chips or gouges are large enough to be harmful, they will leave a pattern on the belt face.
3. To check if chrome plating has worn off, drag a scribe or sharp knife point across the bottom of a groove (between two teeth) with medium pressure.
  - If scribe or knife point slides across groove without digging in or leaving a visible mark, chrome plating is still good.
  - If scribe or knife points digs in and leaves a visible mark, it is cutting the bare aluminum. A knife point will not penetrate the chrome plating.
4. Replace rear sprocket if major tooth damage or loss of chrome exists.

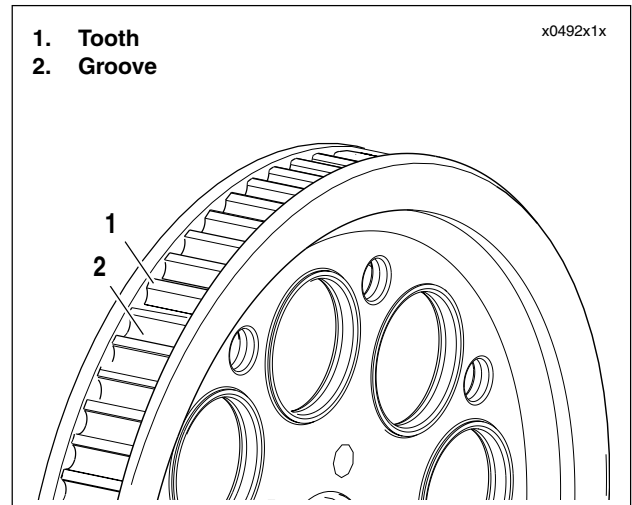

Figure 1-29. Rear Sprocket

### Rear Belt

The rear belt should be checked for unusual wear, cracking, or loss of teeth. Check the belt sprocket for unusual wear, broken teeth, or damaged flange.

See [Figure 1-30](#). Inspect the drive belt at the 1000 mile (1600 km) service interval, and at every 2500 mile (4000 km) service interval thereafter.

### NOTES

- When a drive belt is replaced for any reason other than stone damage, it is recommended that the transmission and rear sprockets also be replaced to increase the longevity of the new drive belt. In the case of stone damage, inspect sprockets for damage and replace as required.
- Condition #1 may develop into #2 or #3 over time. Condition #1 is not grounds for replacing the belt, but it should be watched closely before condition #2 develops which will require belt replacement.

Inspect drive belt for:

- Cuts or unusual wear patterns.
- Outside edge bevelling (#8). Some bevelling is common, but it indicates that sprockets are misaligned.
- outside ribbed surface for signs of stone puncture (#7). If cracks/damage exists near edge of belt, replace belt immediately. Damage to center of belt will require belt replacement eventually, but when cracks extend to edge of belt, belt failure is imminent.
- Inside (toothed portion) of belt for exposed tensile cords (normally covered by nylon layer and polyethylene layer). This condition will result in belt failure and indicates worn transmission sprocket teeth. Replace belt and transmission sprocket.
- Signs of puncture or cracking at the base of the belt teeth. Replace belt if either condition exists.
- Replace belt if conditions #2, #3, #6, or #7 (on edge of belt) exist.

**<https://www.ebooklibonline.com>**

Hello dear friend!

Thank you very much for reading.

Enter the link into your browser.

The full manual is available for immediate download.

**<https://www.ebooklibonline.com>**