

MF 7244

**WORKSHOP
MANUAL**



MASSEY FERGUSON



CONTENT

	Sections
- GENERAL INFORMATION	00
- ENGINE	10
- LIVE PTO	14
- TRANSMISSION	21
- FRONT DRIVE AXLE	25
- HYDROSTATIC TRANSMISSION	29
- BRAKES AND CONTROL	33
- HYDRAULIC SYSTEMS	35
- STEERING	41
- AXLE AND WHEELS	44
- CAB CONDITIONING SYSTEM	50
- ELECTRICAL SYSTEMS	55
- ATTACHMENTS / HEADERS	58
- PRODUCT FEEDING	60
- THRESHING	66
- SEPARATION	72
- STRAW CHOPPER	73
- CLEANING	74
- GRAIN STORAGE	80



MASSEY FERGUSON

TYPE	MODEL IDENTIFICATION
<i>MF 7244</i>	X 5 A

DESCRIPTION OF THE COMBINE IDENTIFICATION NUMBER

Example: $\overset{\text{a}}{\text{5516}} \overset{\text{b}}{\text{5516}} \overset{\text{c}}{\text{00001}} \overset{\text{d}}{\text{}}$ *

a Technical type

d Identification number: 551600001.

It is formed by two parts:

- First part (b), formed by 4 numbers "551 6": it corresponds to the technical type (machine model).
- Second part (c), formed by 5 numbers "00001": they are the production progressive numbers identifying the progressive number of the produced machine model..

* 5516 * 5516 * FOR X5A MOD.

GRAIN HEADER IDENTIFICATION NUMBER

723FOR 4,20 m MODEL

733FOR 4,80 m MODEL

743FOR 5,40 m MODEL

753FOR 6,00 m MODEL

763FOR 6,60 m MODEL

773FOR 7,60 m MODEL

<https://www.ebooklibonline.com>

Hello dear friend!

Thank you very much for reading.

Enter the link into your browser.

The full manual is available for immediate download.

<https://www.ebooklibonline.com>

Section 00 – GENERAL INFORMATION

GENERAL INSTRUCTIONS

IMPORTANT NOTE

All maintenance and repair works described in this manual must be carried out only by the AGCO service network, strictly complying with the instructions given and using the required special tools. Anybody carrying out the above interventions without strictly complying with the prescriptions is fully responsible for the occurred damages.

ADJUSTMENT SHIMS

During any adjustment, select the adjustment shims measuring them individually, by a micrometer, and then summing up the detected values: do not rely on the wrong measurement of the complete pack or on the rated value stated for each ring.

ROTARY SHAFT SEALS

For a correct fitting of the rotary shaft seals, comply with the following precautions:

- before assembly, leave the seals in oil bath, for at least half an hour, using the same oil they should contain;
- carefully clean the shaft and make sure its working surface isn't damaged;
- direct the seal edge to the fluid; in case of hydrodynamic edge, the stripes must be directed so that, considering the shaft rotation direction, the fluid is brought back to the sealing means;
- lay a thin layer of lubricant on the seal edge (oil rather than grease) and fill with grease the gap between seal edge and dust edge in case of double edge seals;
- fit the seal in the relevant housing pressing it or using a drift with flat contact surface; do not beat it with hammer or drift;
- during driving, make sure the seal is perpendicular to its housing and, at the end of the driving, make sure it touches the shoulder;
- to prevent damaging the seal edge against the shaft, lay a suitable protection during installation of both parts.

"O-RINGS"

Lubricate O-rings before fitting them in their seats to prevent any rolling over and twisting, during assembly/installation, thus jeopardizing their sealing action.

SEALANTS

Before laying the sealant on the mating surfaces, prepare them as follows:

- remove possible scales through a metal brush;
- thoroughly degrease the surfaces by one of the following cleansers: trichloroethylene, oil, or a solution of water and soda.

COTTER PINS

While fitting split cotter pins, make sure that their groove is directed towards the effort direction, stressing the pin. Spiral cotter pins do not need any orientation during fitting.

REMARKS ABOUT SPARE PARTS

Use only **AGCO genuine parts**, the only ones bearing this mark.

Only genuine parts guarantee the same quality, life, safety as original parts, as they are the same as those fitted during standard production.

Only **AGCO genuine spare parts** can offer this guarantee.

All spare parts orders must be accompanied by the following data:

- machine model (commercial name) and frame number;
- combine type and number;
- part number of the ordered part, which can be found in or in the "Spare Part Catalogue", used for order processing.

REMARKS ABOUT TOOLS

The tools that AGCO suggests and describes in this manual have been:

- expressly studied and designed to operate on AGCO range combines;
- required to get a reliable repair;
- suitably manufactured and strictly tested to offer efficient and long-lasting working means.

The Repair Technician should remember that having these tools available means:

- working in the best technical conditions;
- getting the best results;
- saving time and effort;
- working more safely.

CAUTION

The wear limits given for some parts must be meant as suggested values, rather they aren't definitely binding. The words "front", "rear", "right" and "left" referred to different parts are meant with the operator sitting on the driver's seat and directed towards the combine standard running direction.

HOW TO MOVE THE COMBINE WITHOUT BATTERY

The cables of the outer power supply unit must be connected only to the relevant terminals of the negative and positive cables of the combine using efficient pliers to get a suitable and stable contact.

Disconnect all services (lights, windscreen wipers, etc...) before starting the combine.

If the operating efficiency of the combine electrical system must be checked, proceed only after connecting the power supply unit. At the end of the check, disconnect all the services and switch the power supply off before disconnecting its cables.

SAFETY PRECAUTIONS

PAY ATTENTION TO THIS SYMBOL



This warning symbol points out important messages involving your personal safety. Carefully read all the suggested safety precautions to avoid potential hazards and safeguard your health and personal safety.

In this manual you will find this symbol together with the following key words:

WARNING – In case of warning aimed at preventing unsuitable repair works, involving potential hazards to the operator's safety.

DANGER – In case of warning aimed at preventing potential hazards to the safety of the operator or other people directly or indirectly involved.



TO PREVENT ACCIDENTS

Most accidents and injuries taking place in workshops are caused by the lapsed compliance with some simple and essential caution and safety precautions. For this reason, **IN MOST CASES THEY CAN BE AVOIDED**: just foresee possible causes and act consequently, with the required caution and care.

The possibility that an accident might occur on any type of machine, no matter how well it was designed and built, should not be disregarded.

A wise and careful service technician is the best warranty against accidents.

The strict compliance with a single and basic safety precaution would be enough to prevent severe accidents.

DANGER. Never carry out any cleaning, lubrication or maintenance operation when the engine is running.

SAFETY PRECAUTIONS

GENERAL INFORMATION

- ◇ Strictly comply with the specified maintenance and repair procedures.
- ◇ Never wear rings, watches, jewels, loose or unbuttoned clothing such as ties, torn clothes, scarves, open jackets or shirts with open zips which could get trapped in moving parts. Wear approved safety clothing, such as for example anti-slip footwear, gloves, goggles, helmets, etc...
- ◇ Never carry out any repair intervention on the machine if someone is sitting on the driver's seat, except for authorized operators assisting in the operation to be carried out.
- ◇ Never operate the machine or use attachments from a place other than sitting in the operator's seat.
- ◇ Never carry out any intervention on the machine when the engine is running, except when specifically indicated.
- ◇ Stop the engine and make sure all pressure is relieved from hydraulic circuits before removing caps, covers, valves, etc...
- ◇ All service interventions must be carried out with the utmost care and attention.
- ◇ Service stairs and ladders used in the workshop on in the field should be built in compliance with the safety rules in force.
- ◇ Disconnect the batteries and label all controls to warn that the machine is being serviced. Lock the machine and any equipment which should be lifted.
- ◇ Never check or fill fuel tanks, accumulator batteries, nor use starting fluid while smoking or next to open flames, as the concerned fluids are flammable.
- ◇ Brakes are ineffective when manually released for service interventions: in such cases, make sure you can keep the machine under continuous control through suitable locks or other.
- ◇ The fuel supply gun must always touch the filler neck. Keep it there until fuel supply stops, to prevent sparks due to static electricity build-up.

- ◇ Use only the prescribed points for towing the machine. Carry out the connections very carefully: make sure that the pins and/or locks are tightly fastened before towing. Do not stand next to the tow bar, ropes or chains working under load.
- ◇ To transfer a faulty machine, use a trailer or low loading platform trolley, when available.
- ◇ To load and unload the machine from the transportation means, select a flat area providing a firm support to the wheels of the trailer or truck. Tightly fasten the machine to the platform of the truck or the trailer and lock the wheels as required by the carrier.
- ◇ For electrical heaters, battery-chargers and similar equipment, use exclusively auxiliary power supplies providing an efficient ground to avoid electrical shock hazards.
- ◇ While lifting or carrying heavy parts, use hoists and similar equipment, with a suitable capacity.
- ◇ Pay special attention to the presence of bystanders.
- ◇ Never pour gasoline or diesel oil in open, wide and low containers.
- ◇ Never use gasoline, diesel oil or other flammable liquids as cleansers: use non-flammable and non-toxic standard solvents.
- ◇ Wear goggles with side guards while cleaning parts by compressed air.
- ◇ Reduce air pressure according to the local or national regulations in force.
- ◇ Never operate the machine in closed areas, without proper ventilation.
- ◇ Do not smoke, use open flames, nor cause sparks nearby when refilling or handling highly flammable matters.
- ◇ Do not use flames as light sources when servicing the machine or checking for possible "leaks".
- ◇ Move with caution when working under the machine, on the machine itself or nearby. Wear the envisaged safety clothing: helmets, goggles and special footwear.
- ◇ During checks to be made with engine running, ask an operator to sit on the driver's seat and keep the service technician under constant visual control at any time.
- ◇ In case of servicing operations to be made outside the workshop, drive the combine to a flat area and lock it. If working on a sloped ground cannot be avoided, first lock the machine and move it to a flat ground as soon as possible, with a certain margin of safety.
- ◇ Dented and bent chains or ropes aren't reliable: do not use them for lifting or towing. While handling them, always wear thick gloves.
- ◇ The chains must be tightly fastened: make sure the fastening device is strong enough to hold the envisaged load. No person should stand next to the fastening device, towing chains or ropes.
- ◇ The area for servicing operations should be kept always CLEAN and DRY. Immediately clean any spillage of water or oil.
- ◇ Do not pile up oil or grease soaked rags: they are a great fire hazard. Always place them in a closed metal container. Before starting the machine or the equipment check, adjust and lock the operator's seat. Make sure no person is standing in the machine or equipment operating range.
- ◇ Do not carry in your pockets any object that could accidentally fall in the machine inner compartments.
- ◇ Whenever you might be hit by projecting metal parts and other, wear an eye mask or goggles with side guards, helmets, special footwear and heavy gloves.
- ◇ During welding operations, use the special safety guards: face shield or tinted goggles, helmets, overalls, special gloves and footwear. All those standing next to the welding station should wear special tinted eye protection. **NEVER LOOK AT THE WELDING ARC UNLESS YOUR EYES ARE SUITABLY PROTECTED.**
- ◇ Metal cables, when used, get frayed: always wear suitable protection while handling them (heavy gloves, goggles, etc...).
- ◇ Handle all parts with the utmost care. Keep your hands and fingers away from gaps, gears and others. Always wear approved protection equipment, such as goggles, heavy gloves and safety footwear.

START-UP

- ◇ Never run the engine in closed areas without suitable ventilation systems for exhaust gas ejection.
- ◇ Never bring your head, body, arms, legs, feet, hands or fingers next to fans or rotating belts.

ENGINE

- ◇ Before removing the radiator cap loosen it very slowly, to relieve pressure from the system. Coolant top-ups must be made only when the engine is stopped or idle, if hot.
- ◇ Never fill up the fuel tank when the engine is running, especially if it is hot, to prevent triggering fires in case of fuel leaks.
- ◇ Never try to check or adjust the fan belt tension when the engine is running. Never adjust the fuel injection pump when the machine is moving.
- ◇ Never lubricate the machine when the engine is running.

ELECTRICAL SYSTEMS

- ◇ When using auxiliary batteries, remember that the cables on both sides must be connected as follows: (+) with (+) and (-) with (-). Do not short-circuit the terminals. **GAS RELEASED FROM BATTERIES IS HIGHLY FLAMMABLE.** During recharging, leave the battery compartment open for an improved ventilation. Never check the battery charge by "jumpers" obtained by laying metal objects on the terminals. Avoid sparks or flames in the area surrounding the batteries. Do not smoke to prevent explosion hazards.
- ◇ Before any intervention, check there are no fuel or power leaks: eliminate these leaks before going on with the work.
- ◇ Never recharge the batteries in closed areas: make sure there is enough ventilation to prevent accidental explosions due to the build-up of gases released while charging.
- ◇ Always disconnect the batteries before any intervention on the electrical system.

HYDRAULIC SYSTEMS

- ◇ Fluid coming out from a very small port can be almost invisible and be strong enough to penetrate the skin. For this reason, use a piece of cardboard or of wood for checking. **NEVER USE YOUR HANDS TO CHECK FOR LEAKS:** in case of any fluid injected into the skin, seek medical aid immediately. Lack of immediate medical care can give origin to serious infections or dermatosis.
- ◇ While checking the system pressures, use the suitable instruments.

WHEELS AND TYRES

- ◇ Make sure that tyres are correctly inflated at the pressure specified by the manufacturer. Regularly check possible damages of rims and tyres.
- ◇ Keep off and stay next to the tyre to correct the inflating pressure.
- ◇ Check the pressure only with unladen machine and cool tyres to prevent a wrong measurement due to overpressure. Never use parts of recovered wheels as improper welding, brazing or heating could have weakened them and cause breakages.
- ◇ Never cut nor weld a rim with fitted inflated tyre.
- ◇ To remove the wheels, lock both front and rear wheels. After lifting the machine to prevent its falling, arrange suitable supports underneath, according to the regulations in force.
- ◇ Deflate the tyre before removing any object caught in the tread.
- ◇ Never inflate tyres using flammable gases as they may cause explosions and injuries to by-standers.

REMOVAL AND INSTALLATION

- ◇ Lift and handle all heavy parts by suitably sized lifting means. Make sure all the parts are held by suitable slings and hooks. Use the appropriate lifting eyebolts. Make sure no one is standing next to the load to be lifted.
- ◇ Handle all parts with great care. Do not put hands and fingers between parts. Wear approved safety clothing such as goggles, gloves and safety footwear.
- ◇ Do not twist metal chains or ropes. Always wear safety gloves to handle cables or chains.

Other data are given in the type-approval certificate.

PRECAUTIONS ISTRUCTION FOR WELDINGS ON COMBINE

In order don't damage the electronic components on the engine, when possible, remove the component from the combine and weld it separately.

If the component can't be disassembled, operate as follows:

- stop the combine in a flat ground and engaging parking brak;
- stop the engine;
- remove the battery negative cable;
- remove the main connection (1) between engine harness and machine main harness;
- dismount the cover (2) and remove all the connectors from ECU re. 3-4 ;
- fasten the harness to the machine structure so that they cannot touch the ECU
- connect the welding machine ground cable as close as possible to the welding point;
- protect the hydraulic and electric components as much as possible, as they could be reached by welding jets.
- on the riassembly of the connector ref. 1-3-4 , pay attention of don't damage or bend the pins connector.

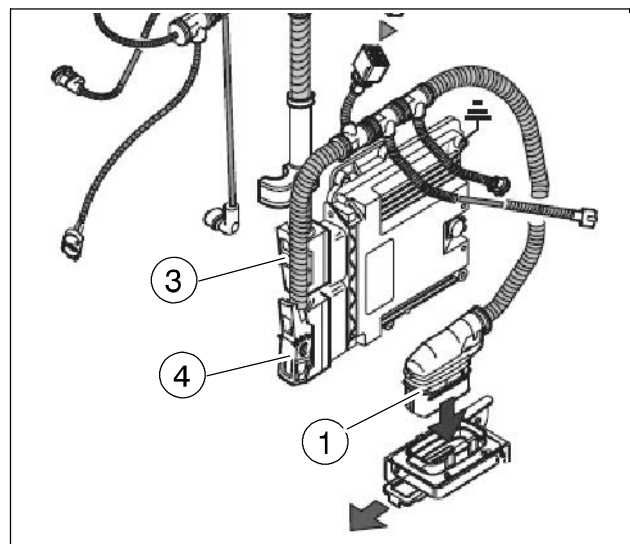
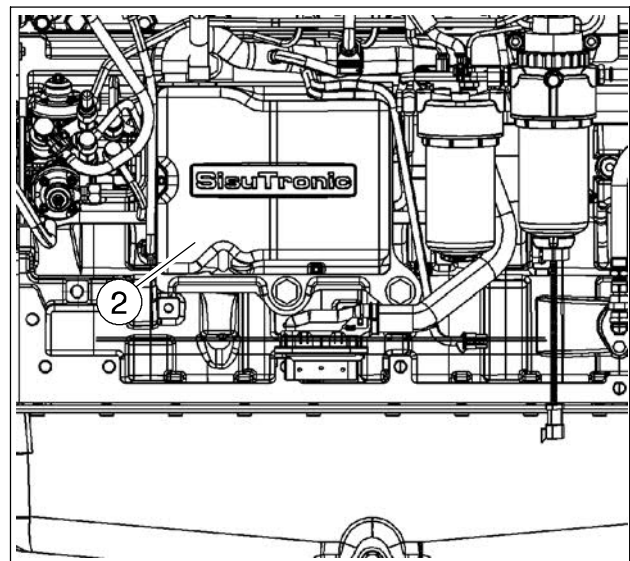
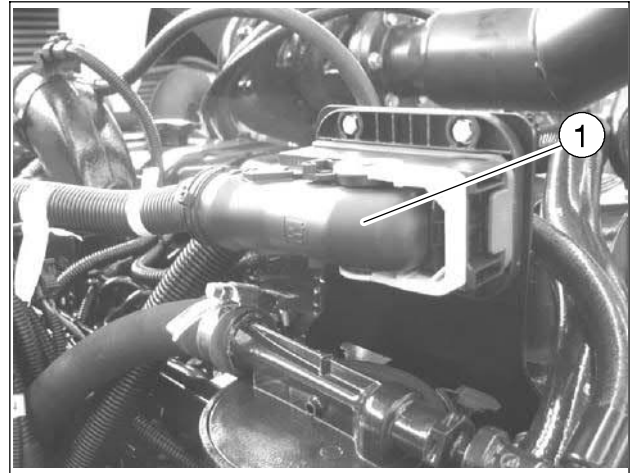

CAPACITIES X 5 A

COMPONENTS TO BE FILLED	QUANTITY dm³ (liters)	INTERNATIONAL SPECIFICATION
Cooling system	40	CUNA 956-16
Fuel tank	450	EN 590-2009
DEF tank	80	DIN 70070 ISO 2241
Engine sump and filter	32	API CJ4 ACEA E9 SAE 15W-40
Only engine sump	29.5	
Brake tank and circuit	0,30	NHTSA 116 DOT 4 SAE J 1704
Gearbox and differential housing	12	API GL5 SAE 80W-90
Final drives	5,5x2	
Tank discharge lower bevel gear pair	0,50	
Hydraulic/hidrostatic tank	36 / 65.5	DIN 51524 Part 2 HV 46 ISO VG 46 HV
Tank elevator bevel gear pair	0,22	NLGI 2
Tank discharge upper bevel gear pair	0,15	
Chaff spreader bevel gear pair	0,35	
Outer track roller supports	0,25x2	API GL5 SAE 80W-90
Compressor	0,26 (210 grams)	PAG ISO 150
Conditioning system	2500 grams	R134a
Nipples	-	NLGI 2
Oilers	-	Biodegradable ISO VG 46
Windscreen washer	1,50	CUNA 956-11

TECHNICAL SPECIFICATION – X 5 A MODEL

	X 5 A
FEED EQUIPMENT	
CUTTING HEADER	
– Terra Control device	standard
– GSAX device	optional
Knife	with knife element fixed by screws
– cutting width	420 ÷ 660
– cutting height (min. and max.)	40 ÷ 1320
– cutting frequency	1220
Auger	double-screw type with toothed torque limiter
– articulated fingers	arranged on the whole width
Reel	with six bars
– drive	by chain, with clutch torque limiter
– vertical and horizontal positioning	electro-hydraulic control
– speed variator	electrically operated (speed 13–60 rpm)
FRONT ELEVATOR	
	multi-purpose type
– lower roller	floating
– bar supporting chains	3
– protection	torque limiter with load spring
– upper shaft speed	415
– lower shaft speed	553
– elevator control belt	by multiple V-type belt
– reverser control	by lever placed near the operator's seat
THRESHER EQUIPMENT	
– stone trap	at the inlet, opening from outside and with lock
BEATER	
– type: grain/maize	with 8 bars
– type: rice	12 toothed bars with cast iron support
– housing width	1346
– diameter	600
– variator belt	1
– variator control	electro-hydraulic
– rotation speed	400 ÷ 1200

	X 5 A
CONCAVE	Electrical control
– control	independent front and rear opening.
– surface m ²	0,83
Grain/barley type:	
– spacing (between wire centers) mm	14,1/28,2
– wire length mm	403 and 630 alternating
– winding angle	106°
– wire diameter mm	3,5
– wire total quantity no.	93
– bars no.	12
Maize type:	
– spacing mm	24
– winding angle	106°
– wire diameter mm	6
– bars no.	9
CONCAVE RAKE	
– bars number	2
– winding angle	14°
– surface m ²	0,11
– positions number	3
REAR BEATER	
– vane number	4 vanes, removable from inside the grain tank
– control	by multiple V-type belt
– rotation speed rpm	820
STRAW WALKERS	
– number	5
– level number	4
– gratings number	5
– length mm	4256
– separating surface m ²	5,73
– rotation speed rpm	177

	X 5 A
CLEANING EQUIPMENT	
FAN	
– standard rotation speed rpm	350 ÷ 1050
– reduced rotation speed (optional) rpm	270 ÷ 840
– vane number	4
– control	V-type belt
GRAIN PAN BOX	
– movement	alternating; opposite the lower sieve box
– drive shaft cycles/min	310
– control	with 2-V-type belt
– grain pan width mm	1346
– grain pan length mm	1723
– grain pan surface m ²	2,31
– grain pan rake surface m ²	0,255
SIEVES	
– upper sieve type	with opposite movement
– upper sieve width mm	CS4 adjustable
– upper sieve length mm	1346
– upper sieve surface m ²	1963
– lower sieve type	2,63
– lower sieve width mm	Closz CS2 adjustable
– lower sieve length mm	1346
– lower sieve surface m ²	1525
TAILINGS	
– type	2,04
– transfer means	to the beater
– auger rotation speed rpm	augers and paddle elevator
CROP TANK	
– type of crop feeding	310
– crop auger elevator control rotation speed rpm	paddle elevator and auger filling the gran tank centrally
– capacity liters	385
– unloading control	6500
– torque limiter type	2HB type belt, with chain and bevel gear box
– unloading tube length m	shearbolt
– discharge speed litres/second	4,0
– crop tank full indicator	85
	light and buzzer

	X 5 A
HYDRAULIC SYSTEM	
– oil tank capacity liters	36
– header distributor max. pressure bar	200
– header pump capacity liters/min	25,5
– engagement distributor max. pressure bar	85
– engagement pump capacity liters/min	4
– driving steering pump capacity liters/min	14
– type	OSPC 125
– max. pressure bar	140
– anti-shock valve max. pressure bar	200
– steering cylinders no.	2
HYDROSTATIC SYSTEM	
– oil tank capacity liters	36
– pump displacement cm ³ /revolution	100
– pump rpm	2620
– pressure relief valve setting bar	420
– motor displacement cm ³ /revolution	100
ENGINE	
– make	SISU
– type	6.6 AWI 746
– cylinders no.	6
– displacement cm ³	6.600
– bore mm	108
– stroke mm	120
– compression ratio	17:1
– valves for cylinder	2 intake + 2 exhaust
– full/no load max engine speed rpm	2200
– power (ECE R120) at 2000 rpm kW	154
– oil sump capacity without filter liters	29.5
– oil sump capacity with filter liters	32
FUEL TANK	
– capacity liters	450
AD Blue TANK	
– capacity liters	80
RADIATOR	
– capacity liters	40
– protection	self-cleaning rotary filter
– aspirator	by engine fan

X 5 A	
ELECTRICAL COMPONENTS	
BATTERY	
– type 12 V A/h	200
– peak current A	1200
STARTER	
– type	ISKRA
ALTERNATOR	
– type	BOSCH
– charging capacity A/h	150
TRACTION	
– standard tyres	620/75 R30
– optional tyres	620/75 R34 650/75 R32 800/65 R32
– gearbox type	with frontal engagements
– gears	3
SPEED WITH 620/75 R30 TYRES	
1 st gear km/h	0 ÷ 6,5
2 nd gear km/h	0 ÷ 13
3 rd gear km/h	0 ÷ 23 (*)
SPEED WITH 650/75 R32 TYRES	
1 st gear km/h	0 ÷ 7
2 nd gear km/h	0 ÷ 13,5
3 rd gear km/h	0 ÷ 24,5 (*)
SPEED WITH 620/75 R34 – 800/65 R32 TYRES	
1 st gear km/h	0 ÷ 7,3
2 nd gear km/h	0 ÷ 14
3 rd gear km/h	0 ÷ 25 (*)
REAR AXLE	
– axle type	adjustable
– standard tyres	400/70–20
– optional tyres	460/70 R24
WEIGHTS	
– weight of the combine without cutting header, with straw chopper and with empty grain tank , fuel tank full and operator (75 kg) kg	11200

(*) In some countries (Germany and Austria ecc.) the road homologation forecasts the max. speed at 20 km/h.

FEATURES

Modd. X 5 A

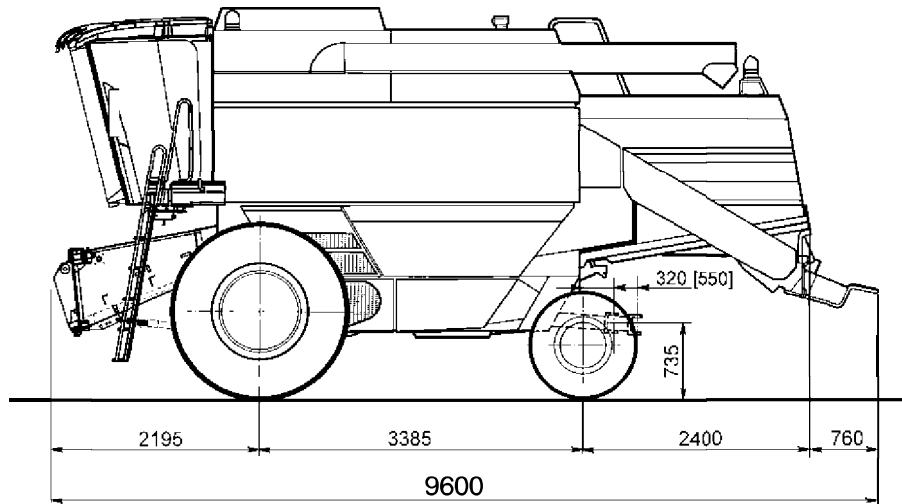

The quote between brackets is referred to the trailer hitch with extension

Modd. X 5 A

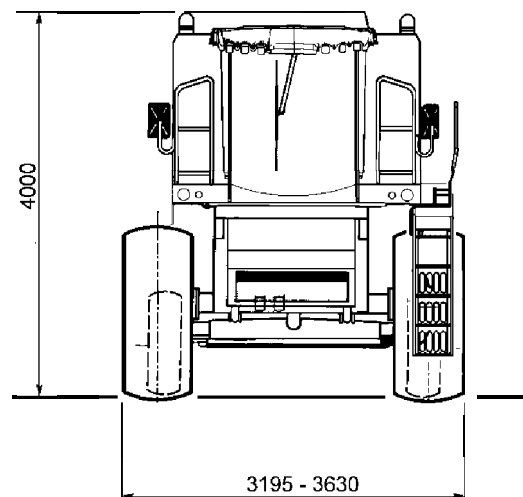

TRACKS WITH SHOES

Modd. X 5 A

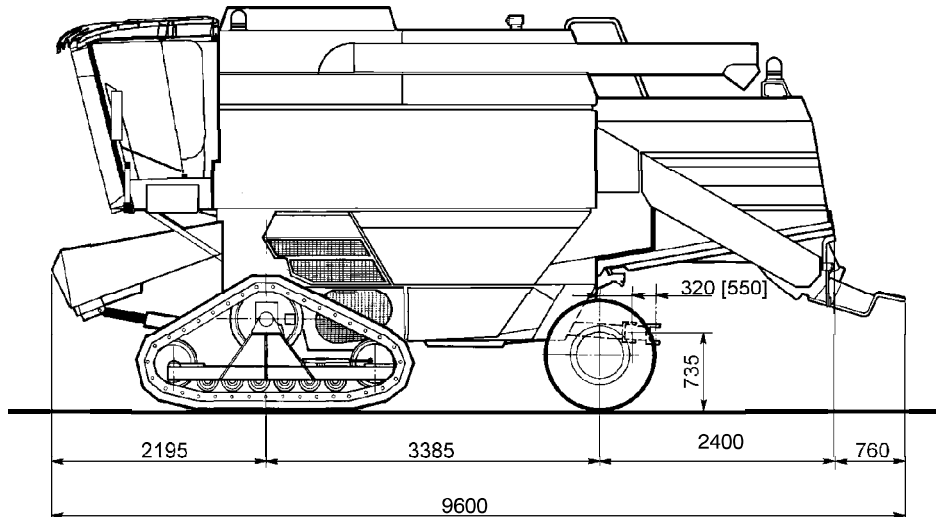

The quote between brackets is referred to the trailer hitch with extension

Modd. X 5 A

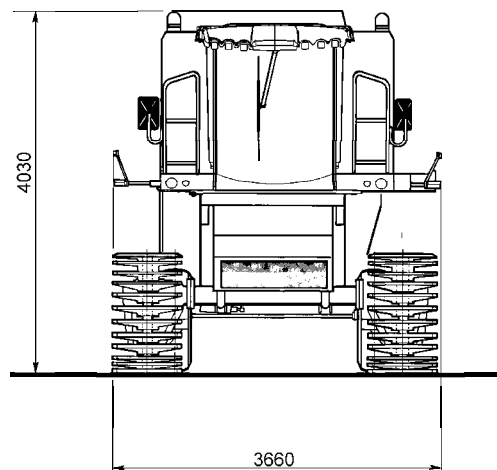



Suggest:

For more complete manuals. Please go to the home page.

<https://www.ebooklibonline.com>

If the above button click is invalid. Please download this document first, and then click the above link to download the complete manual.

Thank you so much for reading

FREE DISTANCE BETWEEN UNLOADING PIPE AND HEADER (mm)

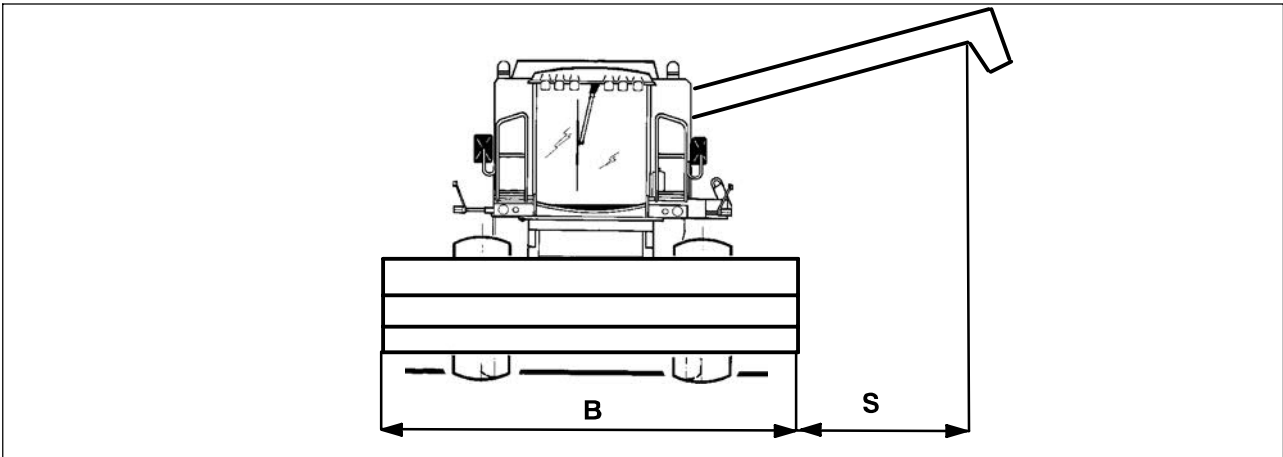

MODD.	GRAIN HEADER	B (mm)	S (mm)
X 5 A	420	4710	2530
	480	5320	2225
	540	5929	1921
	600	6539	1617
	660	7147	1313
	760	8058	1163

AVAILABLE GRAIN HEADERS

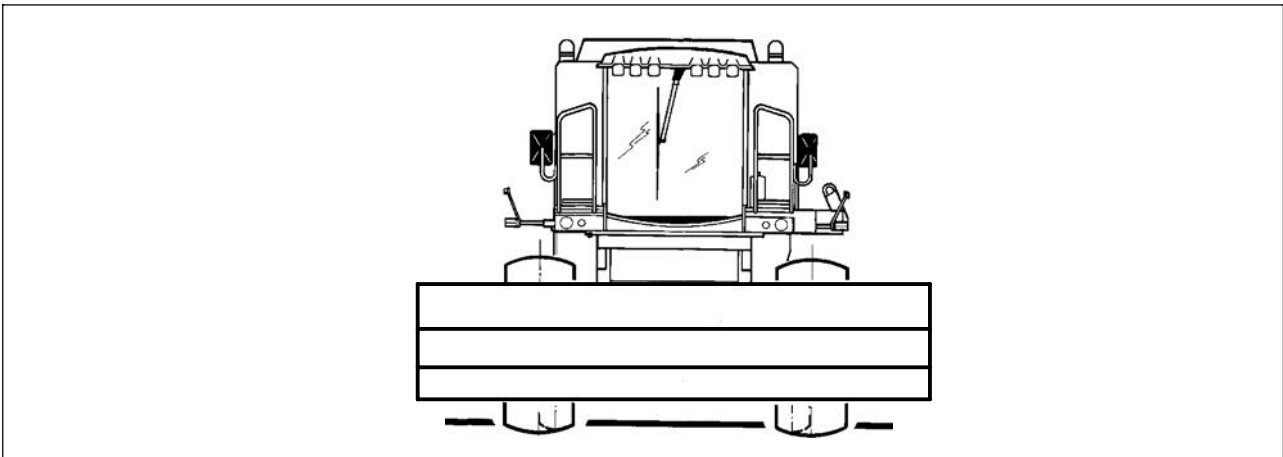

Grain Headers	kg	M 200
420	1170	X
480	1370	X
540	1480	X
600	1600	X
660	1690	X
760	1940	X

FREE DISTANCE BETWEEN UNLOADING PIPE AND HEADER (mm)

with front tyres

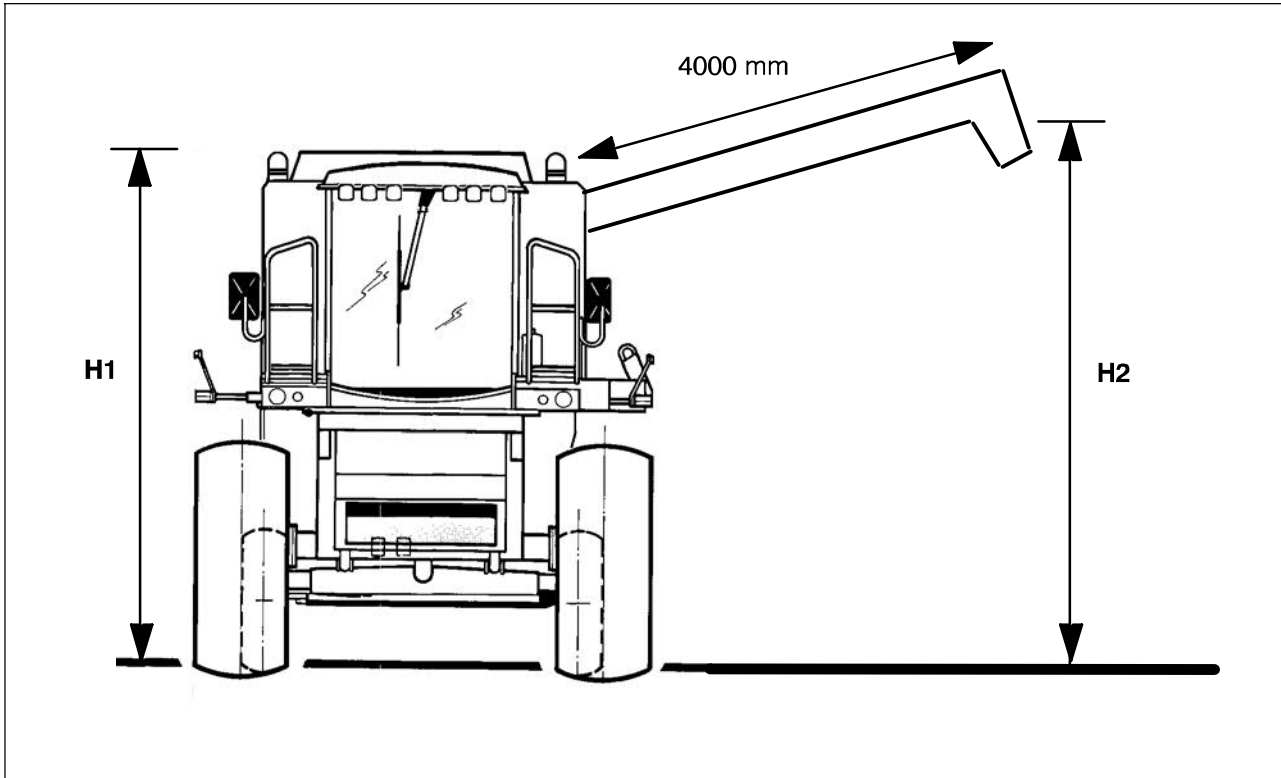

	TYRES TYPE	H1	H2
X 5 A	620/75 R30 (650/75R32, 800/65R32 e 620/75R34)	4000	4185 (4200)

WITH FRONT TRACKS

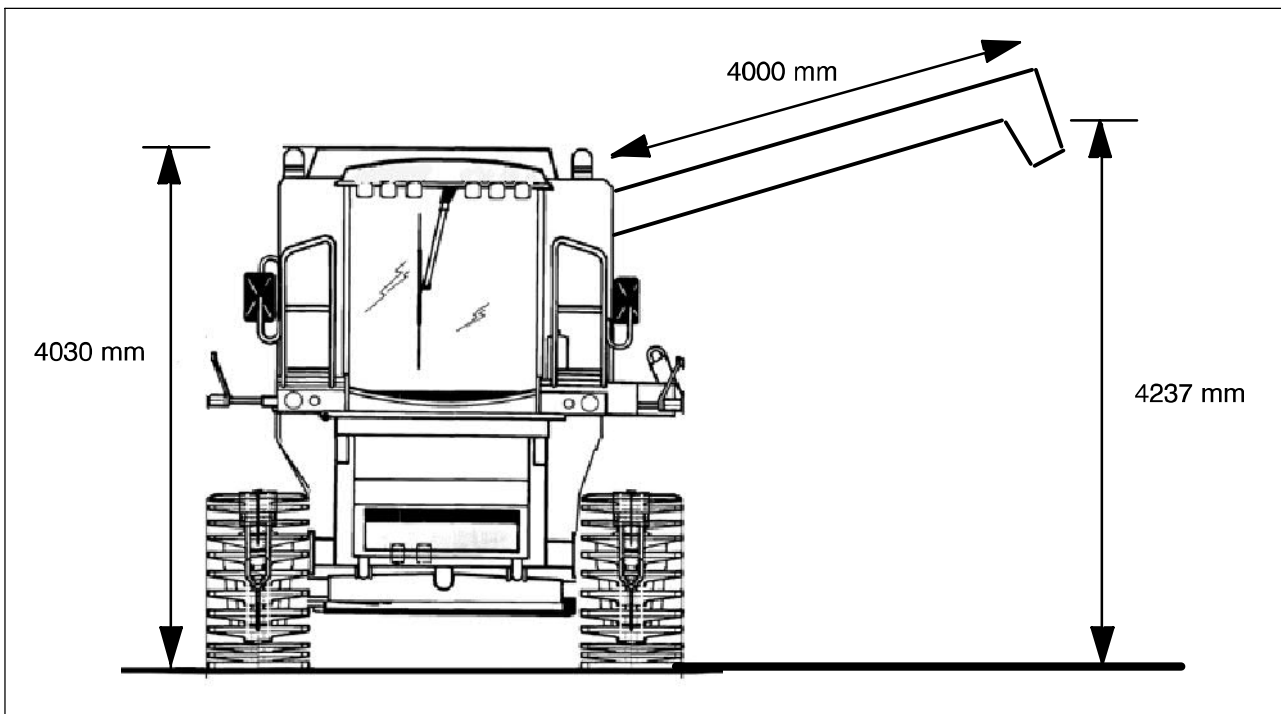

<https://www.ebooklibonline.com>

Hello dear friend!

Thank you very much for reading.

Enter the link into your browser.

The full manual is available for immediate download.

<https://www.ebooklibonline.com>