

| TRACTORS | 6110 | CONTENTS | SECTION |
|-----------------|-------------|--|----------------|
| | 6120 | GENERAL INFORMATION _____ | 1 |
| | 6130 | Tractor identification | |
| | 6140 | Serial numbers | |
| | 6150 | Introduction | |
| | 6160 | Warranty, predelivery and installation | |
| | 6170 | Safety notes | |
| | 6180 | Safety decals | |
| | 6190 | INSTRUMENTS AND CONTROLS _____ | 2 |
| | | OPERATION _____ | 3 |
| | | Running in | |
| | | Driving the tractor | |
| | | MAINTENANCE AND ADJUSTMENTS _____ | 4 |
| | | Maintenance guide | |
| | | Approved Lubricants | |
| | | Maintenance; greasing, changing the engine oil, batteries, fuses | |
| | | SPECIFICATIONS _____ | 5 |
| | | ACCESSORIES AND OPTIONS _____ | 6 |
| | | ALPHABETICAL INDEX _____ | 6 |

North American market only

CALIFORNIA

PROPOSITION 65 WARNING

Diesel engine exhaust and some of its constituents are known to the State of California to cause cancer, birth defects and other reproductive harm.

TRACTOR IDENTIFICATION

SERIAL NUMBER

Important :

NOTE THE SERIAL NUMBER OF YOUR TRACTOR.
ALWAYS QUOTE THE SERIAL NUMBER IN ANY
COMMUNICATION TO YOUR MASSEY FERGUSON
DEALER.

Tractor serial number

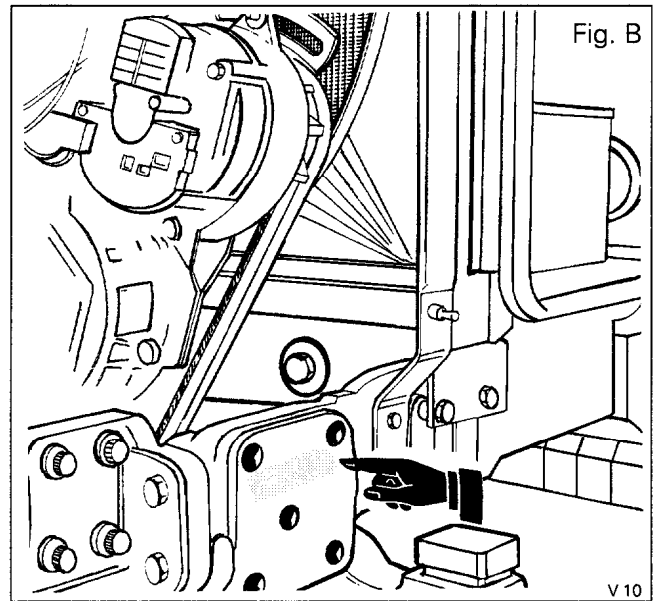
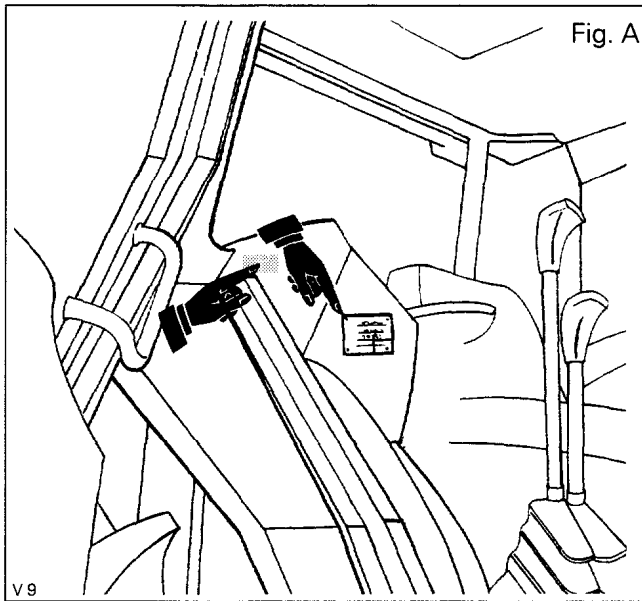

Engine serial number

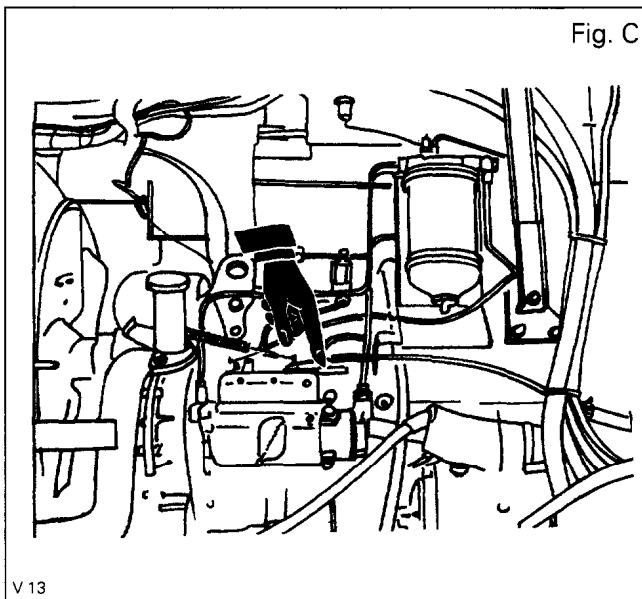

4 cyl. Engine

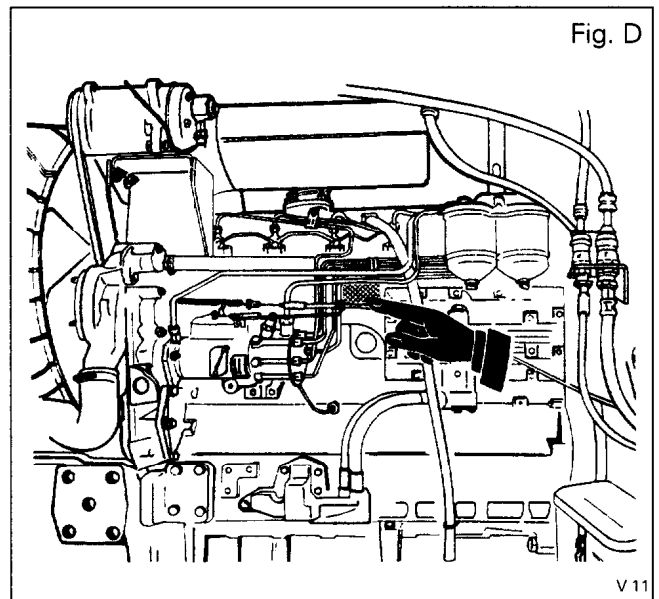

6 cyl. Engine

Cab serial number

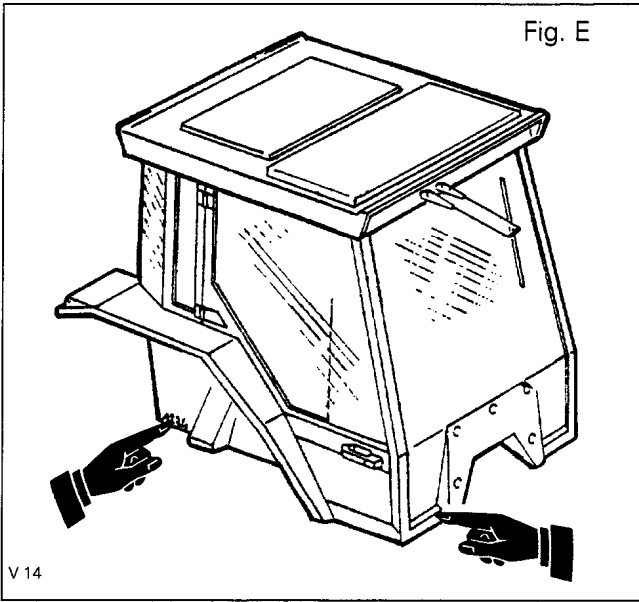

Front axle serial number

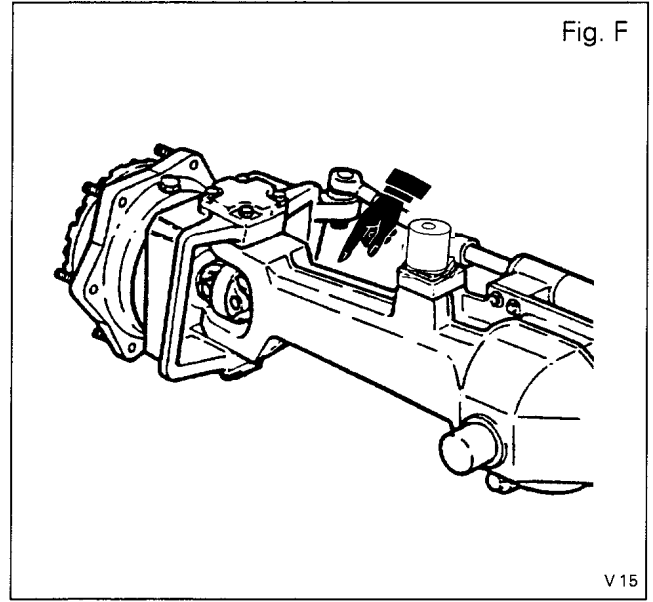

Model

Owner or operator

Nearest Massey Ferguson Dealer

Date of installation

Expiration of warranty

KEEP THIS BOOK IN A SAFE LOCATION FOR REGU-
LAR REFERENCE

<https://www.ebooklibonline.com>

Hello dear friend!

Thank you very much for reading.

Enter the link into your browser.

The full manual is available for immediate download.

<https://www.ebooklibonline.com>

INTRODUCTION - SAFETY PRECAUTIONS AND WARRANTY

| CONTENTS | PAGE |
|---|-------------|
| Introduction _____ | 1-2 |
| Massey Ferguson addresses _____ | 1-2 |
| Warranty, pre-delivery and installation _____ | 1-3 |
| Using the tractor on a public highway _____ | 1-3 |
| Safety - Alert symbol and terms _____ | 1-4 |
| Safety - Tractor and implement _____ | 1-4 |
| Safety - Introduction _____ | 1-4 |
| Safety - A word to the operator _____ | 1-4 |
| Safety - Danger, warning and caution _____ | 1-5 |
| Safety - Decals _____ | 1-5 |
| Safety - Follow a safety program _____ | 1-5 |
| Safety - Prepare for safe operation _____ | 1-7 |
| Safety - Servicing the tractor _____ | 1-9 |
| Safety - Starting _____ | 1-10 |
| Safety - Work safely _____ | 1-11 |
| Safety - After operation _____ | 1-17 |
| Safety - Cab _____ | 1-17 |
| Safety - Asbestos _____ | 1-18 |
| Safety - Decal description _____ | 1-19 à 21 |
| Safety - Decal location _____ | 1-22 |

INTRODUCTION - SAFETY PRECAUTIONS AND WARRANTY

INTRODUCTION

NOTE : *This book is published for world-wide distribution, and the availability of equipment shown either as basic or accessory may vary according to the territory in which the tractor is to be used. Full details of equipment available in your area can be obtained from your Massey Ferguson Dealer.*



This symbol is used throughout the book as a signal to indicate areas where care is required to ensure safe operation and maintenance.

The purpose of this book is to enable the owner and driver to operate and maintain the tractor efficiently in a safe manner. Provided that the instructions are followed carefully the tractor will give years of service in the Massey Ferguson tradition.

The installation of the product by the Dealer gives the opportunity to ensure that these operating and maintenance instructions are understood. Always consult your Dealer if you do not understand any part of this book. It is important that these instructions are understood and observed. Daily maintenance should become a routine and a record of hours in service should be kept.

When replacement parts are needed, only genuine Massey Ferguson service parts should be used. Massey Ferguson Dealers supply genuine parts and can give advice regarding their fitment and use. Extensive damage may occur as a result of the fitment of parts of inferior quality ; customers are advised to buy their service parts only from an authorized Massey Ferguson Dealer.



WARNING : *In some of the illustrations used in this book, panels or guards may have been removed for clarity. Never operate the tractor without these panels and guards fitted.*

Due to wide variations in operating conditions the Company cannot make comprehensive or definitive statements in its publications regarding performance or methods or use of its machines or accept liability for any loss or damage which may result from these statements or from any errors or omissions. If the tractor is to be used for abnormal conditions which may be detrimental (e.g. deep water of paddy fields), consult your Dealer for special instructions, or the warranty may be invalidated.

Customers are strongly advised to use an official Massey Ferguson Dealer in connection with any service Problems and adjustments that may occur. The Massey Ferguson Dealer Network is specially trained & equipped for all service work and to advise customers on the application of the tractor in local conditions.

MASSEY FERGUSON ADDRESSES

The names and addresses of Massey Ferguson Dealers World-Wide can be obtained by writing to one of the following addresses.

AGCO Corporation

Massey Ferguson
4830 River Green Parkway
DULUTH
GA 30136-2574
USA

Massey Ferguson (UK) Ltd.

PO Box 62
Banner Lane
Coventry CV 49 GF
England

Massey Ferguson S.A.

Avenue Blaise Pascal
B.P. 307
60026 BEAUVAIS Cedex
France

Massey Ferguson GMBH

Industriehof Postfach 5 20
3440 ESCHWEGE
Federal Republic of Germany

Massey Ferguson (Australia) Ltd

2 Devonshire Road
Sunshine
VICTORIA 3020
Australia

Massey Ferguson Iberia S.A.

Avenida via de las Dos Castillas, 31
Atica 7 - Edificio 5 - Bajo
28023 Pozuelo de Alarcon
MADRID
Espagne

INTRODUCTION - SAFETY PRECAUTIONS AND WARRANTY

WARRANTY, PRE-DELIVERY & INSTALLATION

The Company, when selling new goods to its Dealers gives a warranty which, subject to certain conditions, guarantees that the goods are free from defects in material and workmanship. Since this book is published for worldwide circulation, it is impossible to detail the exact terms and conditions of warranty that apply to a retail customer in any particular country. Purchasers of new Massey Ferguson equipment should request full details from their supplying Dealer.

In accordance with the Company's policy of continuous improvement to its machines, alterations in the specifications of machines may be made at any time without notice. The Company accepts no responsibility for discrepancies which may occur between the specifications of its machines and the descriptions there of contained in its publications.

A Dealer is required to carry out certain activities when supplying a new Massey Ferguson tractor. These consist of a full pre-delivery inspection to ensure that the tractor supplied is ready for immediate use and full instruction in the basic principles of operations will cover instruments and controls, routine maintenance and safety precautions. All persons who will be concerned with the operation and maintenance of the machine should be present for these instructions.

NOTE : *Massey Ferguson will not accept responsibility for any claim resulting from the fitting of non approved parts or attachments.*

The safety of the operator is a major factor in designing and developing a new Tractor. Designers build in as many safety features as possible. However, every year many accidents occur which could have been avoided by a few seconds thought and a more careful approach to handling farm machinery and implements. You, the operator, can avoid many accidents by observing the following instructions.

In order to provide a better view, certain illustrations shown in this Operator Instruction Book may show an assembly with the safety shield removed. A tractor must never be operated in this condition. Keep all shields in place. If the removal of a shield is necessary to make a repair, it MUST be replaced before operation.

USING THE TRACTOR ON A PUBLIC HIGHWAY

USA and Canada only.

When driving the tractor and implement on the road or highway (under 25 mph), whether at night or during the day, use accessory lights and a Slow Moving Vehicle (SMV) identification Emblem. The use of flashing amber lights is acceptable in most localities. However some localities prohibit their use. Local laws should be checked for all highway lighting and marking requirements. Use the safety chain. Refer to the implement Operator Instruction Book.

All other Territories

Operators should familiarise themselves with the provisions of the Road Traffic Acts and of the regulations made thereunder in order to ensure that when taking the tractor and attachments upon the highway, they comply with the statutory requirements. Always remember to observe the restrictions on the use of vehicles carrying projecting loads or implements.

INTRODUCTION - SAFETY PRECAUTIONS AND WARRANTY

SAFETY - ALERT SYMBOL AND TERMS

This Safety Alert Symbol means ATTENTION ! BECOME ALERT ! YOUR SAFETY IS INVOLVED !



The safety alert symbol identifies important safety messages on machines, safety signs, in manuals, or elsewhere. When you see this symbol, be alert to the possibility of personal injury or death. Follow the instructions in the safety message.

Why is SAFETY important to you ?

- ★ **ACCIDENTS DISABLE AND KILL**
- ★ **ACCIDENTS ARE COSTLY**
- ★ **ACCIDENTS CAN BE AVOIDED**

SAFETY - TRACTOR AND IMPLEMENT

The tractor is a source of power - Mechanical
- Hydraulic

- On its own, the tractor is of little practical value. Only when used in conjunction with an implement or other attachment does it become a working unit.
- This instruction book is compiled to cover those safe working practices that are associated with the base tractor operation.
- It does not cover all operation and safety instructions relevant to all known implements and attachments that may be fitted at the time of tractor delivery or at some future date.
- It is essential that operators use and understand the relevant instruction manual of such implements and attachments.

SAFETY - INTRODUCTION

This safety section of your Operator Instruction Book is intended to point out some of the basic safety situations which may be encountered during the normal operation and maintenance of your tractor, and to suggest possible ways of dealing with these situations. This section is NOT a replacement for other safety practices featured in other sections of this book.

Additional precautions may be necessary, depending on attachments used and conditions at the work site or in the service area. Massey Ferguson has no direct control over tractor application, operation, inspection, lubrication, or maintenance. Therefore it is YOUR responsibility to use good safety practices in these areas.

SAFETY - A WORD TO THE OPERATOR

It is YOUR responsibility to read and understand the safety section in this manual before operating your tractor. You must follow these safety instructions that take you step by step through your working day.

In reading this section, you will note that illustrations have been used to highlight certain situations. Each illustration is numbered and the same number appears in the text in parenthesis. This number is placed at the end of the written text that refers to the illustration.

Remember that YOU are the key to safety. Good safety practices not only protect you, but also the people around you. Study the features in this manual and make them a working part of your safety program.

INTRODUCTION - SAFETY PRECAUTIONS AND WARRANTY

Keep in mind that this safety section is written only for this type of machine. Practice all other usual and customary safe working precautions, and above all - **REMEMBER - SAFETY IS YOUR RESPONSIBILITY. YOU CAN PREVENT SERIOUS INJURY OR DEATH.**

SAFETY - DANGER, WARNING and CAUTION

Whenever you see the words and symbols shown below, used in this book and on decals, you **MUST** take note of their instructions.

 **DANGER** : The symbol and the word **DANGER** indicates an imminently hazardous situation which, if not avoided, will result in **DEATH OR SERIOUS INJURY**.

 **WARNING** : The symbol and the word **WARNING** indicates a potentially hazardous situation. If the instructions or procedures are not correctly followed it could result in **PERSONAL INJURY, OR LOSS OF LIFE**.

 **CAUTION** : The symbol and the word **CAUTION** identifies special instructions or procedures which if not strictly observed, could result in **PERSONAL INJURY**.

IMPORTANT: The word **IMPORTANT** identifies special instructions or procedures which, if not strictly observed could result in **DAMAGE OR DESTRUCTION OF EQUIPEMENT**

NOTE: The word **NOTE** indicates points of particular interest for more efficient and convenient repair or operation.

SAFETY - DECALS

 **WARNING** : **DO NOT** remove or obscure **Danger, Warning, Caution or Instruction Decals**. Replace any **Danger, Warning, Caution or Instruction Decals** that are not readable or are missing. Replacement decals are available from your Dealer in the event of loss or damage. The actual location of these **Safety Decals** is illustrated at the end of this section.

If a used tractor has been purchased, refer to the illustrations at the end of this section to ensure that all the safety warning decals are in the correct position and are readable.

SAFETY - FOLLOW A SAFETY PROGRAM

For safe operation

For safe operation of an agricultural tractor, you must be a qualified and authorized operator. To be qualified you must understand the written instructions supplied in this Operator Instruction Book, have training, and know the safety rules and regulations for the job.

Some regulations specify that no one under the age of 16 years, for example, may operate power machinery. This includes tractors. It is your responsibility to know what these regulations are, and obey them, in the operating area or situation.

These will include, but are not limited to, the following instructions for safe tractor operation.

 **WARNING** : An operator should not use **alcohol or drugs which can change his alertness or co-ordination**. An operator on prescription or "over the counter" drugs needs medical advice on whether or not he or she can safely operate machines.

Observe the following

- Never allow children or unqualified persons to operate your tractor.
- Securely fasten your seat belt when the tractor has a ROPS (Roll Over Protective Structure frame or cab).
- Where possible, avoid operating the tractor near ditches, embankments and holes.
- Reduce speed when turning, crossing slopes, and on rough, slippery, or muddy surfaces.
- Stay off slopes too steep for safe operation.
- Watch where you are going, especially at row ends, on roads, and around trees.
- Do not permit others to ride on the tractor or the implement.
- Operate the tractor smoothly - no jerky turns, starts or stops.

INTRODUCTION - SAFETY PRECAUTIONS AND WARRANTY

- Hitch only to the drawbar and hitch points recommended, and never above the centre line of the rear axle.
- When the tractor is stopped, apply the parking brake securely.
- Never modify or remove any part of the equipment.
- Keep others away from your area of work.
- Never use attachments unless they are properly matched to your tractor.

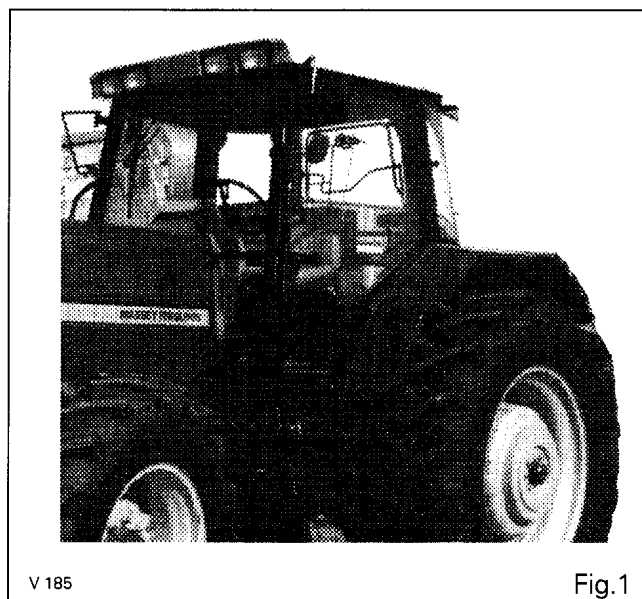

SAFETY - ROPS

Roll Over Protective Structures

A Roll Over Protective Structure (ROPS or Safety Cab) and seat belt is fitted as standard equipment to the tractor at the time of factory assembly. If the ROPS or Safety Cab was deleted by the original purchaser or has been removed, it is recommended that you equip your tractor with a Roll Over Protective Structure or Safety Cab and a seat belt. ROPS or Safety Cab are effective in reducing injuries during overturn accidents. Overturning a tractor without ROPS or Safety Cab can result in serious injury or death.

Operation

- Before using the tractor ensure that the ROPS frame or Safety Cab is not damaged, that it is securely fastened to the tractor.
- DO NOT attach chains, ropes, or cables to the ROPS or Safety Cab for pulling purposes; this will cause the tractor to tip backwards. Always pull from the tractor drawbar.
- Always wear your seat belt - adjusted snugly. Never wear the seat belt if the tractor is not equipped with upright ROPS or Safety Cab.
- Check the seat belt for damage. A damaged seat belt must be replaced.

Damage to the ROPS or Safety Cab

If the tractor has rolled over or the ROPS or Safety Cab has been damaged (such as striking an overhead object during transport), the ROPS or Safety Cab must be renewed to provide the original degree of protection.

After an accident, check for damage to the ROPS or Safety Cab, operator's seat, seat belt and seat belt mountings. Before you operate the tractor, replace all damaged parts.

DO NOT WELD, DRILL, BEND OR STRAIGHTEN THE ROPS OR SAFETY CAB. To do so reduces the protection it offers.



Suggest:

For more complete manuals. Please go to the home page.

<https://www.ebooklibonline.com>

If the above button click is invalid. Please download this document first, and then click the above link to download the complete manual.

Thank you so much for reading

SAFETY - PREPARE FOR SAFE OPERATION

Protect yourself

Wear all the protective clothing and personal safety devices issued to you or called for by job conditions. Don't take chances (Fig. 2).

You may need :

- A hard hat.
- Safety glasses, goggles, or face shield.
- Hearing protection.
- Respirator or filter mask.
- Foul weather clothing.
- Reflective clothing.
- Heavy gloves (neoprene for chemicals, leather for rough work).
- Safety shoes.

DO NOT wear loose clothing, jewellery or other items and tie up long hair which could catch on controls or other parts of the tractor.

Learn where fire extinguishers and first-aid or emergency equipment is kept and where to get help in a hurry. Make sure you know how to use this equipment (Fig. 3).

Know your equipment

Know your tractor. Know how to operate all equipment on your machine and the implements and attachments used with it. Know the purpose of all the controls, gauges and dials. Know the rated load capacity, speed range, braking and steering characteristics, turning radius, and operating clearances.

Keep in mind that rain, snow, ice, loose gravel, soft ground, etc. can change the way your tractor operates. **Under poor conditions, slow down and be extra careful, engage four-wheel drive, if fitted.**

Study the **DANGER, WARNING, or CAUTION** safety signs on your tractor and the information signs also.

READ THIS OPERATOR INSTRUCTION BOOK BEFORE STARTING THE ENGINE.

STUDY IT BEFORE YOU START WORK (Fig. 4)

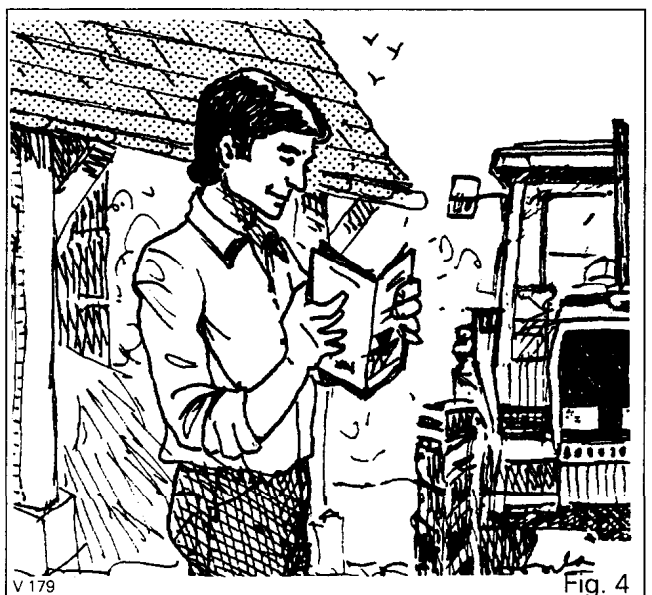
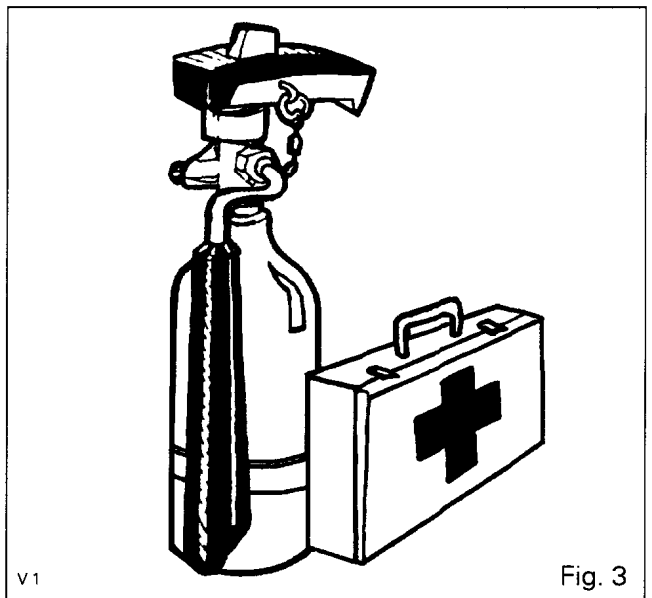
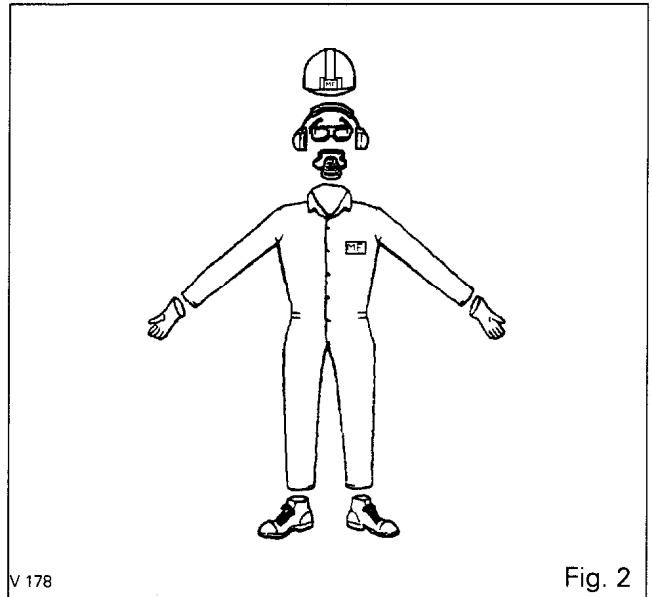

INTRODUCTION - SAFETY PRECAUTIONS AND WARRANTY

IF THERE IS SOMETHING IN THE MANUAL YOU DON'T UNDERSTAND, ASK SOMEONE (such as your equipment Dealer) TO EXPLAIN IT TO YOU.

IMPORTANT : This manual covers general safe practices for agricultural tractors. It must always be kept with the tractor. For further copies contact your Massey Ferguson Dealer.

Use all available protective and safety devices

Keep all protective devices in place and securely fastened. Make certain all guards, shields and safety signs are properly installed, as specified, and are in good condition.

To help keep you and others around you safe, your tractor should be equipped with :

- Roll Over Protective Structure (ROPS) with safety belt/restraint or a cab. A seat belt and ROPS is recommended in North America.

- Tractor PTO shield.

Your tractor may also need :

- A fire extinguisher.
- Rear view mirror.
- SMV (slow moving vehicle) emblem.
- Additional safety guards, lights or decals.
- A back-up alarm.

Know which devices are required for safe operation of your tractor. Use them. Make sure they are in place and in good condition. Never remove or disconnect any safety device.

Check the equipment

Before you begin your working day, take time to check your tractor and ensure that all systems are in good operational condition.

- Check for loose, broken, missing, or damaged parts. Have everything put into good repair.
- Make certain all safety devices are in place.
- Check ROPS and seat belt for damage. (A damaged ROPS or safety belt MUST be replaced).
- Ensure that implements and attachments are properly installed and that the tractor and implement PTO rev/min ratings match.
- Check the tyres for cuts, bulges and correct pressure. Replace worn or damaged tyres.

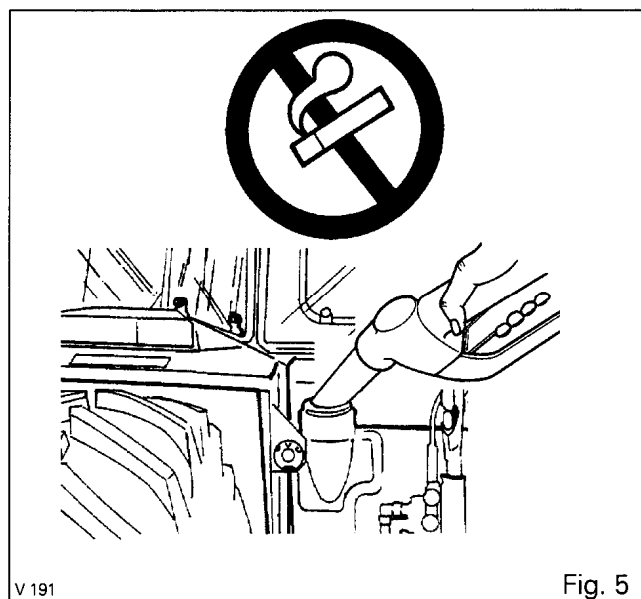

CAUTION : Access to fuel filler by means of climbing onto non-rigid linkage elements is not permissible.

- Check foot and parking brakes for proper operation. Adjust if necessary.
- Stop the engine and wait for it to cool before refuelling.
- DO NOT smoke while refuelling the tractor (Fig. 5). Keep any type of open flame away.
- Check the engine oil level and add oil if required.
- Perform all maintenance procedures outlined in the maintenance and adjustment section of this manual.

<https://www.ebooklibonline.com>

Hello dear friend!

Thank you very much for reading.

Enter the link into your browser.

The full manual is available for immediate download.

<https://www.ebooklibonline.com>