

## Introduction and Safety in the Workshop

### Section 1

#### Table of Contents

INTRODUCTION .....	2
SAFETY ALERT SYMBOL AND TERMS .....	4
SAFETY IN THE WORKSHOP .....	4
SAFETY - A WORD TO THE MECHANIC .....	4
SAFETY - DANGER, WARNING AND CAUTION .....	4
SAFETY DECALS .....	5
GENERAL .....	5
PERSONAL CONSIDERATIONS .....	5
EQUIPMENT CONSIDERATIONS .....	5
GENERAL CONSIDERATIONS .....	6
OPERATIONAL CONSIDERATIONS .....	7
SERVICING TECHNIQUES .....	7

# Introduction and Safety in the Workshop

---

## INTRODUCTION

The purpose of this manual is to assist Dealers and Distributors in the efficient repair and maintenance of Massey Ferguson farm machinery. Carrying out the procedures as detailed, together with the use of special tools where appropriate, will enable the operations to be completed within the time stated in the Repair Time Schedule.

To assist with locating information, each section of the manual is preceded by a contents page listing the operations. Each instruction within an operation has a sequence number, and to complete the operation in the minimum time it is essential that these instructions are performed in numerical sequence commencing at 1, unless otherwise stated.

When applicable, these sequence numbers identify the components in the appropriate illustration. Where an operation requires the use of a special tool, the tool number is quoted under the operation heading and is repeated in, or following, the instruction involving its use.

## Indexing

For convenience the manual is divided into sections and parts, each page bearing a section and part number. The sections are subdivided into numbered operations. Example: 1-7A would be Operation 1 in Section 7, Part A. This simplifies cross referencing and enables the subject to be found easily.

## Definition of Terms

The operation descriptions generally used throughout the schedules may be defined as follows:

**Removal and Refitment** - Remove and refit an original part or assembly, or a new part or assembly which does not involve additional operations or time.

**Install** - Install a part or component not previously fitted e.g., accessories.

**Overhaul** - Remove a part or assembly, dismantle, inspect and recondition, re-assemble, and re-install making all necessary adjustments.

**Dis-assembly and Re-assembly** - The terms 'Dis-assembly' and 'Re-assembly' indicate the orderly taking apart of an assembly into individual parts and rebuilding it into the original assembly.

**Adjust** - Make the necessary adjustments to restore specified setting or performance.

**Check** - Ascertain if a setting or condition is within the limits of acceptability, either as defined in the manufacturer's specifications or, where a dimension is not specified, in the judgement of the mechanic. The checking of fixings, e.g. nuts and bolts, includes tightening to the specified torque figures listed in this Manual.

**Servicing** - All technical work undertaken to maintain the machine in working order.

## Special Tools

Where the use of a special tool is specified in an operation the tool number will be shown under the operation heading and also following the instruction requiring its use.

The use of the special tools mentioned in the text contributes to a safe, efficient and profitable repair. Some operations are impracticable without their use, for example, the refitment of the differential unit. Distributors and Dealers are therefore urged to check their tools against the list provided.

For further details, refer to the special tool catalogue for this range of tractors, Section 14 of this manual.

## Repairs and Replacements

When service parts are required it is essential that only genuine AGCO replacements are used.

Attention is particularly drawn to the following points concerning repairs and the fitting of replacement parts and accessories:

Safety features embodied in the tractor may be impaired if other than genuine parts are fitted.

In certain territories, legislation prohibits the fitting of parts not to the tractor manufacturer's specification. Torque wrench setting figures given in the Workshop Manual must be strictly adhered to. Locking devices where specified must be fitted. If the efficiency of a locking device is impaired during removal it must be renewed.

The tractor warranty may be invalidated by the fitting of other than genuine AGCO parts. All AGCO replacements have the full backing of the manufacturer's warranty. Massey Ferguson Dealers are obliged to supply only genuine service parts.

## Repair of the Tractor

Follow these important points:

**CLEAN THE TRACTOR AND DIAGNOSE THE FAULT BEFORE DIS-ASSEMBLY.**

If possible, make a complete diagnosis to determine the extent of the repair required. Take precautions, as necessary, to prevent dirt or other foreign material entering the hydraulic, fuel or air systems.

**DO NOT MIX PARTS.**

Make particular note of special parts which should not be interchanged.

**DURING DIS-ASSEMBLY, CLEAN PARTS THOROUGHLY AND INSPECT THEM FOR WEAR, DAMAGE, ETC.**

**LABEL PARTS. PROTECT PRECISION OR MACHINED SURFACES.**

# Introduction and Safety in the Workshop

---

## SAFETY ALERT SYMBOL AND TERMS



This safety alert symbol means **ATTENTION! BECOME ALERT! YOUR SAFETY IS INVOLVED!**

The safety alert symbol identifies important safety messages on

machines, safety signs, in manuals, or elsewhere. When you see this symbol, be alert to the possibility of personal injury or death. Follow the instructions in the safety message.

## Why is SAFETY important to you?

**\* ACCIDENTS DISABLE and KILL \***

**\* ACCIDENTS are COSTLY \***

**\* ACCIDENTS can be AVOIDED \***

## SAFETY IN THE WORKSHOP

This safety section of your Workshop Service manual is intended to point out some of the basic safety situations which may be encountered during the normal repair operations of the tractor, and to suggest possible ways of dealing with these situations.

Additional precautions may be necessary, depending on the type of repair and the conditions at the work site or in the workshop. AGCO has no direct control over the repair procedures, operation, inspection, lubrication or general maintenance. Therefore it is YOUR responsibility to use good safety practices in these areas.

## SAFETY - A WORD TO THE MECHANIC

It is your responsibility to read and understand this safety section before carrying out repairs on AGCO equipment.

Remember that YOU are the key to safety. Good safety practices not only protect you, but also the people around you. Study the features in this section and the rest of the manual and make them a working part of your safety programme. Practice all other usual and customary safe working precautions, and above all – **REMEMBER – SAFETY IS YOUR RESPONSIBILITY. YOU CAN PREVENT SERIOUS INJURY OR DEATH.**

## SAFETY - DANGER, WARNING AND CAUTION

Whenever you see these signal words and symbol  used in this manual and on decals, you **MUST** take note of their instructions.

### Danger

The symbol and the word **DANGER** indicates an **imminently hazardous situation which, if not avoided, will result in DEATH OR VERY SERIOUS INJURY.**

### Warning

The symbol and the word **WARNING** indicates a **potentially hazardous situation. If the instructions or procedures are not correctly followed it could result in PERSONAL INJURY, OR LOSS OF LIFE.**

### Caution

The symbol and the word **CAUTION** is used to indicate a **potentially hazardous situation that, if not avoided, may result in MINOR OR MODERATE INJURY.**

**IMPORTANT:** The word **IMPORTANT** is used to identify special instructions which, if not observed, could result in damage to, or destruction of the machine, process or its surroundings.

**NOTE:** The word **NOTE** is used to indicate points of particular interest for more efficient and convenient repair or operation.

**<https://www.ebooklibonline.com>**

Hello dear friend!

Thank you very much for reading.

Enter the link into your browser.

The full manual is available for immediate download.

**<https://www.ebooklibonline.com>**

## SAFETY DECALS



### Warning

**DO NOT remove or obscure Danger, Warning or Instruction Decals.**

Replace any Danger, Warning, Caution or Instruction Decals that are not readable, damaged or are missing.

## GENERAL

Practically all service work involves the need to drive a tractor. The Operator Instruction Book, supplied with each tractor or implement, contains detailed safety precautions relating to driving, operating and servicing. These precautions are as applicable to the service mechanic as they are to the operator, and should be read, understood and practised by all personnel.

Prior to undertaking any maintenance, repair, overhaul, dismantling or re-assembly operations, whether within a workshop facility or out 'in the field', consideration should be given to factors that may have an effect upon Safety, not only upon the mechanic carrying out the work, but also upon bystanders.

- DO NOT allow children or bystanders around or on the machine while it is being adjusted, serviced, repaired or operated.

## PERSONAL CONSIDERATIONS

### Clothing

- The wrong clothes or carelessness in dress can cause accidents. Check to see that you are suitably clothed. DO NOT wear loose clothing or long hair around equipment.

Some jobs require special protective equipment.

### Eye Protection

- The smallest eye injury may cause loss of vision. Injury can be avoided by wearing the proper eye protection when engaged in chiselling, grinding, discing, sanding, welding, painting etc.
- Wear safety goggles or safety glasses appropriate to the job in hand.

### Breathing Protection

- Fumes, dust and paint spray are unpleasant and harmful. These can be avoided by wearing respiratory protection.

### Hearing Protection

- Loud noise may damage your hearing and the greater the exposure the worse the damage. If you think the noise is excessive, wear ear protection.

### Hand Protection

- It is advisable to use a protective barrier cream before work to prevent irritation and skin contamination. After work clean your hands in soap and water. Solvents such as white spirit, paraffin, etc., may harm the skin.
- Wear gloves when ever possible to protect your hands. DO NOT wear rings or wrist watches when working on machinery, as they could catch on moving parts and cause serious injury.

### Foot Protection

- Substantial or protective footwear with reinforced toe-caps (safety shoes) will protect your feet from falling objects. Additionally, oil-resistant soles will help to avoid slipping.

### Special Clothing

- For certain work it may be necessary to wear flame or acid-resistant clothing.

## EQUIPMENT CONSIDERATIONS

### Machine Guards

- Before using any machine, check to ensure that the machine guards are in position and serviceable. These guards not only prevent parts of the body or clothing coming in contact with the moving parts of the machine, but also ward off objects that might fly off the machine and cause injury. Ensure that missing guards are replaced.

### Lifting Appliances

- Always ensure that lifting equipment, such as chains, slings, lifting brackets, hooks and eyes are thoroughly checked before use. If in doubt, select stronger equipment than is necessary.
- Never stand under a suspended load or raised implement.
- Avoid injury through incorrect handling of components. Make sure you are capable of lifting the object. If in doubt get help.

### Jacking

- Select a jack strong enough to carry the load.
- Stabilise the tractor and chock the wheels.
- Put support stands under the tractor. Lower the jack and let the tractor rest on the stands.
- DO NOT go under a tractor supported by a chain hoist or jack.

# Introduction and Safety in the Workshop

---

## Compressed Air

- The pressure from a compressed air line is often as high as 7 bar (100 lbf/in<sup>2</sup>). It is perfectly safe if used correctly. Any misuse may cause injury.
- Never use compressed air to blow dust, filings, dirt etc., away from your work area unless the correct type of nozzle is fitted and eye protection is used.
- Compressed air is not a cleaning agent, it will only move dust, etc., from one place to another. Look around before using an air hose as bystanders may get grit into their eyes, ears or skin.
- Used approved air guns, wear safety goggles, and use proper shielding to protect others in the work area.
- Never point an air nozzle at a persons body.

## Hand Tools

- Many cuts, abrasions and injuries are caused by defective tools. Never use the wrong tool for the job, as this generally leads either to some injury, or to a poor job.
- Never use:-
  - A hammer with a loose head or split handle.
  - Spanners or wrenches with splayed or worn jaws.
  - Spanners or files as hammers; or drills, clevis pins or bolts as punches.
- Grind off mushroom heads from chisels. The sharp edges can tear your skin if the tool slips. And, when the tool is struck, chips could break off and fly into your eyes.
- Keep a handle on every file to prevent the tang from piercing your palm or wrist if the file should slip or catch.
- For removing or replacing hardened pins use a copper or brass drift rather than a hammer.
- For dismantling, overhauling and assembly of major components, always use Special Service Tools recommended.

These will reduce the work effort, labour time and repair cost.

- Always keep tools clean and in good working order.

## Electricity

- Electricity has become so familiar in day to day usage, that its potentially dangerous properties are often overlooked. Misuse of electrical equipment can endanger life.
- Before using any electrical equipment - particularly portable appliances - make a visual check to make sure that the cable is not worn or frayed and that the plugs, sockets, etc., are intact; make sure you know where the nearest isolating switch is located. Always use an earthed (grounded) 3 pin electrical cord.

## GENERAL CONSIDERATIONS

### Solvents

- Use only cleaning fluids and solvents that are known to be safe. Certain types of fluids can cause damage to components such as seals, etc., and can cause skin irritation. Solvent labels should be checked that they are suitable not only for the cleaning of components and individual parts, but also that they DO NOT affect the personal safety of the user.

### Housekeeping

- Many injuries result from tripping or slipping over or on, objects or material left lying around by a careless worker. Prevent these accidents from occurring. If you notice a hazard, don't ignore it - remove it.
- A clean, hazard-free place of work improves the surroundings and daily environment for everybody.
- Keep work organised and clean. Wipe up spills of any kind to minimise the possibility of a fall. Keep tools and parts off the floor to further reduce the possibility of tripping and causing serious injury.

### Fire

- Fire has no respect for persons or property. The destruction that fire can cause is not always fully realised. Everyone must be constantly on guard.
  - Extinguish matches, cigars, cigarettes, etc., before throwing them away.
  - Work cleanly, disposing of waste material into proper containers.
  - Locate the fire extinguishers and find out how to operate them.
  - DO NOT allow or use open flame near the fuel tank, fuel lines, battery, hydraulic hoses or component parts
- When using a gas torch, always keep a fully charged fire extinguisher within reach.
- In the event of fire:
  - DO NOT panic - warn those near and raise the alarm.

### First Aid

- In the type of work that mechanics are engaged in, dirt, grease, fine dust, etc. all settle upon the skin and clothing. If a cut, abrasion or burn is disregarded it may be found that an infection has formed within a short time. What appears at first to be trivial could become painful and injurious. It only takes a few minutes to have a fresh cut dressed, but it will take longer if you neglect it. Make sure you know where the First Aid box is located and that it is kept fully stocked at all times.

## OPERATIONAL CONSIDERATIONS

- Stop the engine, if at all possible, before performing any service.
- Place a warning sign on self propelled equipment which, due for service or overhaul, would be dangerous to start. Disconnect the battery leads if leaving such a unit unattended and remove the key.
- DO NOT attempt to start the engine while standing beside the tractor or attempt to by-pass the safety start switch. Make a practise of checking that neutral start switches are functioning correctly.
- Avoid prolonged running of the engine in a closed building or in an area with inadequate ventilation as exhaust fumes are highly toxic.
- Always turn the radiator cap to the first stop to allow pressure in the system to dissipate when the coolant is hot.
- Never work beneath a tractor which is on soft ground. Always take the unit to an area which has a hard level working surface - concrete is preferred.
- If it is found necessary to raise the equipment for ease of servicing or repair, make sure that safe and stable supports are installed, beneath axle housings, casings, etc., before commencing work.
- Certain repair or overhaul procedures may necessitate 'Separating the tractor', either at the engine gearbox or gearbox/rear axle locations. These operations are simplified by the use of the Tractor Splitting Kit/Stands (Use the AGCO MF.3012 Tractor Splitting Track, also available, MF.3013 Cab Stands). Should this equipment not be available, then every consideration must be given to stability, balance and weight of the components, especially if a cab is installed.
- Use footsteps or working platforms when servicing those areas that are not within easy reach.
- Cleanliness of the tractor hydraulic system is essential for optimum performance. When carrying out service and repairs plug all hose ends and component connections to prevent dirt entry.
- Clean the exterior of all components before carrying out any form of repair. Dirt and abrasive dust can reduce the efficiency and working life of a component and lead to costly replacement. Use of high pressure washer or steam cleaner is recommended.
- Before loosening any hoses or tubes connecting implements to remote control valves, etc., switch off the engine, remove all pressure in the lines by operating levers several times. This will remove the danger of personal injury by oil pressure.
- Prior to pressure testing, make sure all hoses and connectors not only of the equipment, but also those of the test equipment, are in good condition and tightly sealed. Pressure readings must be taken with the gauges specified. The correct procedure should be rigidly observed to prevent damage to the system

or equipment, and to eliminate the possibility of personal injury.

- Hydraulic fluid escaping under pressure can have enough force to penetrate the human skin. To locate a leak under pressure, use a small piece of cardboard, never use your hands. If you are injected with hydraulic fluid seek medical help immediately.
- When equipment or implements are required to be attached to the hydraulic linkage, either for testing purposes or for transportation, the 'Position Control' should be used.
- Always lower equipment to the ground when leaving the tractor.
- If high lift attachments are installed on a tractor beware of overhead power, electric or telephone cables when travelling. Drop the attachment near to ground level to increase stability and minimise risks.
- DO NOT park or attempt to service the equipment on an incline. If unavoidable, take extra care and chock all wheels.
- Observe recommended precautions as indicated in this Service Manual when dismantling the air conditioning system as escaping refrigerant can cause frostbite.
- Prior to removing wheels and tyres from a tractor, check to determine whether additional ballast (liquid or weights) has been added. Seek assistance and use suitable equipment to support the weight of the wheel assembly. Store the wheels so that they cannot fall over and cause injury.
- When inflating tyres beware of over inflation - constantly check the pressure. Over inflation can cause tyres to burst and result in personal injury.

Heed these safety precautions, and the ones found in this manual, and you will protect yourself accordingly. Disregard them and you may become injured for life.

## SERVICING TECHNIQUES

### Service Safety

Appropriate service methods and proper repair procedures are essential for the safe, reliable operation of all farm machinery as well as the personal safety of the individual doing the work.

This Service Manual provides general directions for accomplishing service and repair work with tested, effective techniques. Following them will help assure that a thorough repair is successfully completed.

There are numerous variations in procedures, techniques, tools, and parts for servicing tractors, as well as in the skill of the individual doing the work. This Manual cannot possibly anticipate all such variations and provide advice or cautions as to each. Anyone who departs from the instructions provided in this Manual must realise that one compromises their personal safety and the tractor's

# Introduction and Safety in the Workshop

---

integrity by the choice of repair methods, tools and/or parts.

## Service Techniques

Clean the exterior of all components before carrying out any form of repair. Dirt and abrasive dust can reduce the efficient working life of a component and lead to costly replacement.

Time spent on the preparation and cleanliness of working surfaces will pay dividends in making the job easier and safer and will result in overhauled components being more reliable and efficient in operation.

Use cleaning fluids which are known to be safe. Certain types of fluid can cause damage to 'O' rings and cause skin irritation. Check the label on Solvents to ensure that they are suitable for the cleaning of components and also that they DO NOT risk the personal safety of the user.

Replace 'O' rings, seals or gaskets whenever they are disturbed. Never mix new and old seals or 'O' rings, regardless of condition. Always lubricate new seals and 'O' rings with hydraulic oil before installation.

When replacing component parts use the correct tool for the job.

## Hoses and Tubes

Always replace hoses and tubes if their ends are damaged.

When installing a new hose, loosely connect each end and make sure the hose takes up the designed position before tightening the connection. Clamps should be tightened sufficiently to hold the hose without crushing and to prevent chafing or contact with other parts.

Before removing hoses or tubes make sure they are identified so that they can be correctly re-assembled.

Be sure any hose which has been installed is not kinked or twisted after it is tightened.

## Bearings

Bearings which are considered suitable for further service should be cleaned in a suitable solvent and immersed in clean lubricating oil until required.

DO NOT spin bearings with compressed air. The centrifugal force could cause a ball or roller to fly outward with enough force to cause an injury.

Installation of a bearing can be classified in two ways: press fit on rotating parts such as shafts, and gears, and push fit into static locations such as reduction gear housings. Where possible, always install the bearing onto the rotating component first.

Always use pullers or a press to remove and/or install bearings, bushings and cylinder sleeves, etc. Use hammers, punches and chisels only when absolutely necessary and be sure to wear safety goggles.

## Shims

When shims are removed, tie them together and identify them as to location. Keep shims clean and flat until they are re-installed.

## Gaskets

Be sure the holes in the gasket correspond with the lubricant passages in the mating parts. If gaskets are to be made, select material of the proper type and thickness. Be sure to cut holes in the right places. Always renew gaskets prior to re-installation.

## Lip Type Seals

Lubricate the lips of the lip-type seals before installation. Use petroleum jelly. DO NOT use grease. Ensure that the oil seal is fitted the right way round, the lip of the seal is placed next to the lubricant that is sealed. Some seals have a second auxiliary lip, which is used to prevent the ingress of dirt to the seal lip.

If, during installation, the seal lip must pass over a shaft that has splines, a keyway, rough surface or a sharp edge, the lip can be easily damaged. Always use a seal protector, when one is provided.

## Use of Bolts in Blind Holes

Use bolts of the correct length. A bolt which is too long may 'bottom' before the head is tight against the part it is to hold. The threads can be damaged when a 'long' bolt is removed. If a bolt is too short, there may not be enough threads engaged to hold the part securely.

## Locking Devices

Lockwashers, tab washers or split pins are used to lock nuts and bolts.

Flat metal locks must be installed properly to be effective. Bend one end of the lock around the edge of the part. Bend the other end against one flat surface of the nut or bolt head. Always install new locks.

Always fit new split pins/cotter pins and bend the ends round so that they will not catch in clothing and help to prevent cuts.

## Cables and Wires

When removing or disconnecting a group of cables or wires, tag each one to assure proper re-assembly.

Always clip back wires and cable looms properly to prevent chafing, cable damage and possible damage by fire.

## 3600 Tractor

### Section 2

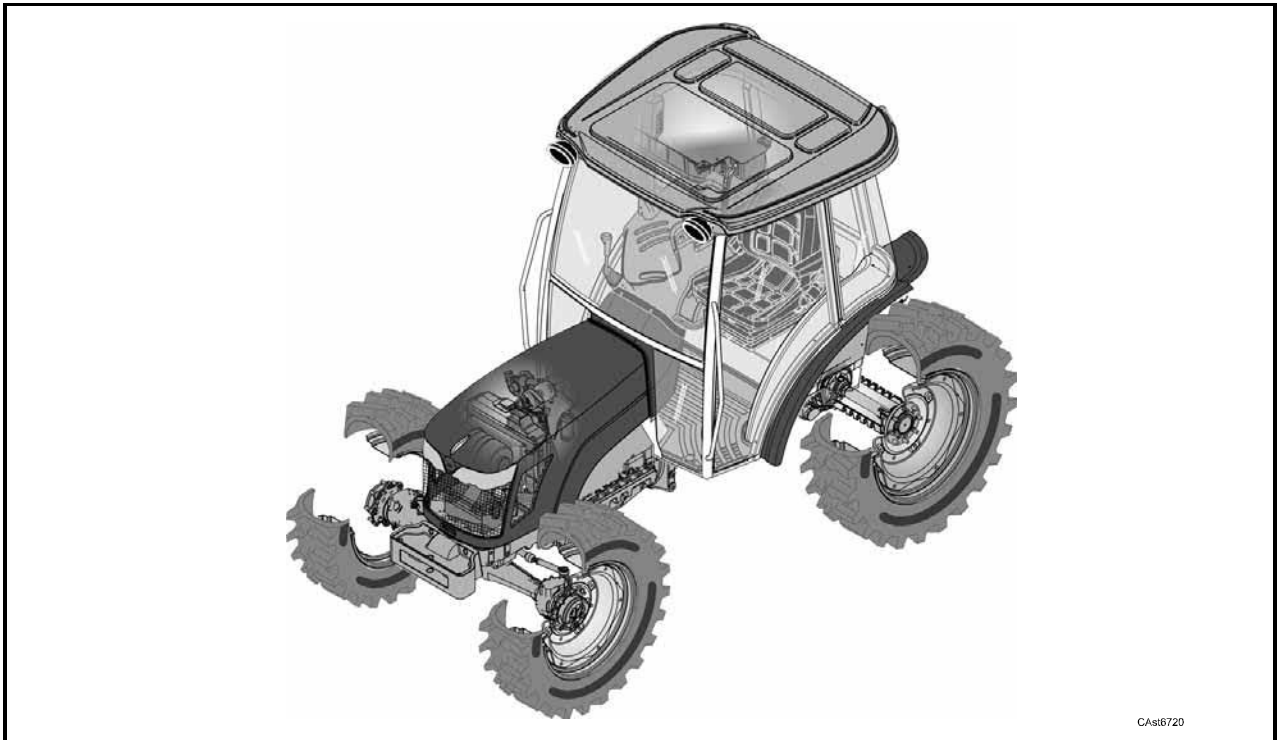

Page left blank intentionally

# General Information

## Section 2

### Table of Contents

MANUAL USE .....	4
MAINTENANCE .....	4
REPAIR .....	4
INFORMATION PROPERTY .....	4
AGREEMENTS AND DEFINITIONS .....	4
AGREEMENTS .....	4
DEFINITIONS .....	4
TYPOGRAPHIC AGREEMENTS .....	4
MEASUREMENTS .....	4
SYMBOLOLOGY .....	5
GENERAL DESCRIPTION .....	6
GENERAL .....	6
HOSES AND TUBES .....	6
O-RING FLAT FACE SEAL FITTINGS .....	6
SHIMMING .....	6
ROTATING SHAFT SEALS .....	6
O-RINGS .....	7
BEARINGS .....	7
SPRING PINS .....	7
HARDWARE TORQUE VALUES .....	7
NOTES FOR SPARE PARTS .....	7
NOTES FOR EQUIPMENT .....	7
NOTICES .....	7
HOW TO MOVE THE MACHINE WITH THE BATTERY REMOVED .....	7

# General Information

---

## MANUAL USE

End users

- Installer
- User
- Maintenance operator

### Maintenance

CONSULT THIS MANUAL THOROUGHLY, as proper functioning and good efficiency of mechanical organs depends mostly on constant and correct routine maintenance ensuring product integrity and expected life duration.

In case of any damages or anomalies, quick intervention of trained operators can avoid future impairment and lengthen the working life.

### Repair

The disassembly/assembly procedures have been outlined for a total product overhauling. They have also been described in sequence through photographs with relevant explanation for specific interventions, thus obtaining a complete and safe guide for each and every phase of an operation.

Moreover, the attentive group inspection leads to a correct repair work estimation that could merely require dismounting only few components, and thus operating partially on the group.

### Information property

This manual should be considered as Massey Ferguson Limited confidential information. All rights reserved.

No part of this manual may be reproduced, in any form or by any means, without prior written permission of Massey Ferguson Limited. Only the customer, whom the manual, together with the transmission, has been issued to, is allowed to use this document, and only in order to use, maintain and repair the transmission.

Massey Ferguson Limited declares that the subject of this manual consists with the technical and safety specifications of the tractor that the manual is referred to. The manufacturer shall not be held liable for direct or indirect damages to persons, things or animals due to an improper use of this document or of the transmission or to a different use of them, which does not comply with what is provided for in this manual.

Agco Limited  
Abbey Park  
Stoneleigh, Kenilworth, CV8 2TQ England  
Tel. +44 (0) 24 7669 4400  
www.agcocorp.com

## AGREEMENTS AND DEFINITIONS

### Agreements

Illustrations like pictures, drawings and components in this manual are NOT in scale, because of limited space and editing limits, therefore they are NOT reliable to obtain values about size or weight.

Illustrations are supposed to point out the various handling sequences and phases of the tractor and its components.

### Definitions

Left side: it is the left side of the tractor considering the vehicle in running conditions.

Right side: it is the right side of the tractor considering the vehicle in running conditions.

### Typographic agreements

**NOTE:** The notes, pointed out externally to the text they refer, include important information.



### Warning

**Warning indications point out the procedures, whose partial or complete non-observance can damage the machine or the connected equipment.**



### Danger

**Danger indications point out the procedures, whose partial or complete non-observance can injure the operator.**

### Measurements

This manual indicates all measurements in International System (SI).

## Symbology

DESCRIPTION	SYMBOLS
WARNING/DANGER	
REMOVE/INSTALL seals-gaskets-filters	
OIL FILLING OR OIL LEVEL/OIL DRAIN	
LUBRICATION/GREASING	
ADJUSTMENTS/MEASUREMENTS tightening torques-preloads-backlash	
SPECIAL TOOLS	
SEALING/LOCKING FLUIDS APPLICATION	
MARKING	
DISASSEMBLY/ASSEMBLY OF BULKY PARTS OR SUBASSEMBLIES	
WARNING: respect assembly orientation	
CLEANING CAREFULLY	
APPLY HIGH PRESSURE FLUID	

# General Information

---

## GENERAL DESCRIPTION

All maintenance and repair operations described in this manual should be carried out exclusively by authorized workshops. All instructions detailed should be carefully observed and special equipment indicated should be used if necessary.

Everyone who carries out service operations described without carefully observing these prescriptions will be directly responsible for deriving damages.

### General

Clean the exterior of all components before carrying out any form of repair. Dirt and dust can reduce the efficient working life of a component and lead to costly replacement.

Time spent on the preparation and cleanliness of working surfaces will pay dividends in making the job easier and safer and will result in overhauled components being more reliable and efficient in operation. Use cleaning fluids which are known to be safe. Certain types of fluid can cause damage to O-Rings and cause skin irritation. Solvents should be checked that they are suitable for the cleaning of components and also that they do not risk the personal safety of the user.

Replace O-Rings, seals or gaskets whenever they are disturbed. Never mix new and old seals or O-Rings, regardless of condition. Always lubricate new seals and O-Rings with hydraulic oil before installation.

When replacing component parts, use the correct tool for the job.

### Hoses and Tubes

Always replace hoses and tubes if the cone end or the end connections on the hose are damaged.

When installing a new hose, loosely connect each end and make sure the hose takes up the designed position before tightening the connection. Clamps should be tightened sufficiently to hold the hose without crushing and to prevent chafing.

After hose replacement to a moving component, check that the hose does not foul by moving the component through the complete range of travel.

Be sure any hose which has been installed is not kinked or twisted.

Hose connections which are damaged, dented, crushed or leaking, restrict oil flow and the productivity of the components being served. Connectors which show signs of movement from the original swagged position have failed and will ultimately separate completely.

A hose with a chafed outer cover will allow water entry. Concealed corrosion of the wire reinforcement will subsequently occur along the hose length with resultant hose failure.

Ballooning of the hose indicates an internal leakage due to structural failure. This condition rapidly deteriorates and total hose failure soon occurs.

Kinked, crushed, stretched or deformed hoses generally suffer internal structural damage which can result in oil restriction, a reduction in the speed of operation and ultimate hose failure.

Free-moving, unsupported hoses must never be allowed to touch each other or related other surfaces. This causes chafing which reduces hose life.

### O-Ring Flat Face Seal Fittings

When repairing O-Ring face seal connectors, the following procedures should be observed.



## Warning

**Never disconnect or tighten a hose or tube that is under pressure, if in doubt, actuate the operating levers several times with the engine switched off prior to disconnecting a hose or tube.**

Release the fittings and separate the hose or tube assembly, then remove and discard the O-Ring seal from the fitting.

Dip a new O-Ring seal into clean hydraulic oil prior to installation. Install a new O-Ring into the fitting and, if necessary, retain in position using petroleum jelly.

Assemble the new hose or tube assembly and tighten the fitting finger tight, while holding the tube or hose assembly to prevent it from turning.

Use two suitable wrenches and tighten the fitting to the specified torque according to the size of the fitting.

To ensure a leak-free joint is obtained, it is important that the fittings are not over or under torqued.

### Shimming

At each adjustment, select adjusting shims, measure them individually using a micrometer and then sum up recorded values.

Do not rely on measuring the whole shimming set, which may be incorrect, or on rated value indicated for each shim.

### Rotating Shaft Seals

To correctly install rotating shaft seals, observe the following instructions:

- let the seal soak into the same oil as it will seal for at least half an hour before mounting;
- thoroughly clean the shaft and ensure that the shaft working surface is not damaged;
- place the sealing lip towards the fluid. In case of a hydrodynamic lip, consider the shaft rotation direction and orient grooves in order that they deviate the fluid towards the inner side of the seal;
- coat the sealing lip with a thin layer of lubricant (oil rather than grease) and fill with grease the gap between the sealing lip and the dust lip of double lip seals;

- insert the seal into its seat and press it down using a flat punch. Do not tap the seal with a hammer or a drift;
- take care to insert the seal perpendicularly to its seat while you are pressing it. Once the seal is settled, ensure that it contacts the thrust element if required;
- to prevent damaging the sealing lip against the shaft, place a suitable protection during installation.

## O-Rings

Lubricate the O-Rings before inserting them into their seats. This will prevent the O-Rings from rolling over and twisting during mounting which will jeopardize sealing.

## Bearings

It is advisable to heat the bearings to 80 to 90 °C before mounting them on their shafts and cool them down before inserting them into their seats.

## Spring Pins

When mounting roll pin spring pins, ensure that the pin notch is oriented in the direction of the effort to stress the pin.

## Hardware Torque Values

Check the tightness of hardware periodically.

Use the following charts to determine the correct torque when checking, adjusting or replacing hardware on the tractor.

**IMPORTANT:** Torque values listed are for general use only. Make sure fastener threads are clean and not damaged.

**NOTE:** A torque wrench is necessary to properly torque hardware.

## Notes for Spare Parts

Only genuine parts guarantee same quality, life, safety as original components as they are the same as mounted in production. Only the genuine spare parts can offer this guarantee.

All spare parts orders should be complete with the following data:

- machine model (commercial name) and chassis number;
- engine type and number;
- part number of the ordered part, which can be found on the “Parts Book”, which is the base for order processing.

## Notes for Equipment

Equipment which proposes and shows in this manual are as follows:

- studied and designed expressly for use on company machines;
- necessary to make a reliable repair;
- accurately built and strictly tested to offer efficient and long-lasting working means.
- We also remind the repair personnel that having these equipment means:
- work in optimal technical conditions;
- obtain best results;
- save time and effort;
- work more safely.

## Notices

Wear limits indicated for some details should be intended as advised, but not binding values. The words “front”, “rear”, “right hand”, and “left hand” referred to the different parts should be intended as seen from the operator’s seat oriented to the normal sense of movement of the machine.

## How to Move the Machine with the Battery Removed

Cables from the external power supply should be connected exclusively to the respective terminals of the Machine positive and negative cables using pliers in good condition which allow proper and steady contact.

Disconnect all services (lights, wind-shield wipers, etc.) before starting the Machine.

If it is necessary to check the machine electrical system, check it only with the power supply connected. At check end, disconnect all services and switch the power supply off before disconnecting the cables.

## General Information

---

Page left blank intentionally



**Suggest:**

**For more complete manuals. Please go to the home page.**

**<https://www.ebooklibonline.com>**

**If the above button click is invalid. Please download this document first, and then click the above link to download the complete manual.**

**Thank you so much for reading**

## General Specifications

### Section 2

#### Table of Contents

PRODUCT IDENTIFICATION .....	10
CAB .....	12
PLATFORM TRACTORS .....	12
PLATFORM TRACTORS .....	12
GENERAL DESCRIPTION .....	14
TARE WEIGHTS KG (LB)* .....	16
MAX PERMISSIBLE WEIGHTS KG (LB) .....	17
TARE WEIGHTS KG (LB)* .....	17
MAX PERMISSIBLE WEIGHTS KG (LB) .....	18
DIMENSIONS WITH PLATFORM .....	19
DIMENSIONS WITH CAB .....	20
STEERING ANGLE .....	21
STEERING RADIUS .....	21
TRAVEL SPEED .....	22
TYRE .....	27
TYRE PRESSURE .....	27
BATTERY .....	31
DESCRIPTION AND OPERATION .....	31
BATTERY REPLACEMENT .....	31
MAINTENANCE .....	32
SERVICING .....	32
DRY CHARGED .....	33
CHARGING THE BATTERY .....	33
NORMAL (TOP-UP) CHARGING .....	33
RECHARGING DEEPLY DISCHARGED .....	33
TESTS .....	33
SPECIFIC GRAVITY .....	34
PERFORMANCE TEST .....	34
TEST CHARGING .....	35
COMMON CAUSES OF BATTERY FAILURES .....	35
EMERGENCY STARTING THROUGH ANOTHER BATTERY .....	36
BATTERY CONNECTION USING SUITABLE CABLES .....	36
ALTERNATOR .....	38
GENERAL MAINTENANCE TABLE .....	39

# General Specifications

## PRODUCT IDENTIFICATION

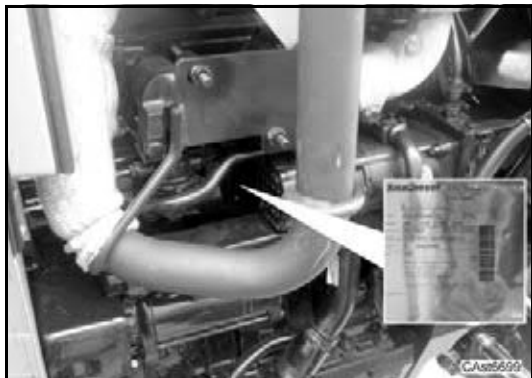

Engine

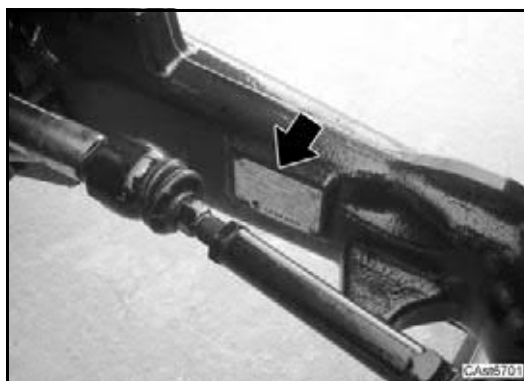

4WD front axle serial number

Each tractor is identified by means of tractor model and serial numbers. As a further identification, engine and chassis are provided with identification numbers.

To ensure prompt, efficient service when ordering parts or requesting repairs from authorized dealer, record these numbers in the spaces provided.

Machine model and serial number plate (located on the rear side of the vehicle adjacent to the linkage):



2WD front axle serial number

Dealer telephone number:

\_\_\_\_\_

Dealer fax number:

\_\_\_\_\_

Dealer e-mail address:

\_\_\_\_\_

Machine serial number (also located on right-hand side of front axle support):

\_\_\_\_\_

Engine serial number (located on the right side of engine block):

\_\_\_\_\_

Date of delivery:

\_\_\_\_\_

Dealer name and address:

\_\_\_\_\_

**<https://www.ebooklibonline.com>**

Hello dear friend!

Thank you very much for reading.

Enter the link into your browser.

The full manual is available for immediate download.

**<https://www.ebooklibonline.com>**