



**MASSEY FERGUSON**

# MF 2700E

Series Tractors

Models: 2705E / 2706E



# SERVICE MANUAL

**FROM MASSEY FERGUSON**

# **Workshop Service Manual**

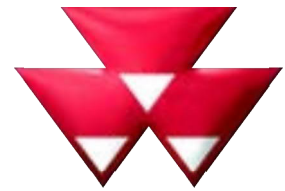

**MASSEY FERGUSON**

**2705E**

**2706E**

<b>1 General</b>	1-1
<b>1.1 Introduction</b>	1-3
1.1.1 The service manual	1-3
1.1.2 Replacement parts	1-3
1.1.3 Units of measurement	1-3
1.1.4 Serial number plate	1-3
1.1.5 Engine identification	1-4
1.1.6 Chassis number	1-5
<b>1.2 Specifications</b>	1-6
1.2.1 Engine specifications	1-6
1.2.2 Electrical specifications	1-7
1.2.3 Power take-off specifications	1-7
1.2.4 Mechanical transmission specifications	1-7
1.2.5 Hydrostatic transmission specifications	1-7
1.2.6 Power take-off specifications	1-8
1.2.7 Hydraulic specifications	1-8
1.2.8 Fuel specifications	1-8
1.2.9 Operating slope angle	1-9
1.2.10 Capacities	1-9
1.2.11 Lubrication specifications	1-9
1.2.12 Tire inflation pressures	1-9
1.2.13 Maximum load capacity	1-10
<b>1.3 General dimensions</b>	1-11
1.3.1 Dimensions	1-11
1.3.2 Major components	1-12
<b>1.4 Lubrication / fill points</b>	1-13
1.4.1 Lubrication and maintenance chart	1-13
1.4.2 Lubrication fill and drain locations - mechanical	1-14
1.4.3 Lubrication fill and drain locations - hydrostatic	1-15
<b>1.5 General precautions for disassembly and installation</b>	1-16
1.5.1 Precautions for disassembling and installing	1-16
1.5.2 Precautions when installing according to standard parts	1-16
<b>1.6 Tightening torque chart</b>	1-19
<b>1.7 Conversion table</b>	1-21
<b>1.8 Safety introduction</b>	1-22
1.8.1 Safety alert symbol	1-22
1.8.2 Safety messages	1-22
1.8.3 Informational messages	1-22
1.8.4 Safety signs	1-22
<b>1.9 Operation</b>	1-24
1.9.1 Prepare for operation	1-24
1.9.2 Roll over protective structure	1-24
1.9.3 General information	1-24
1.9.4 Personal protective equipment	1-28
1.9.5 Seat instruction	1-28
1.9.6 Shield and guards	1-28
1.9.7 Power take-off safety	1-29
1.9.8 Exhaust warning	1-30
1.9.9 Agricultural chemicals	1-30
1.9.10 Travel on public roads	1-30

**<https://www.ebooklibonline.com>**

Hello dear friend!

Thank you very much for reading.

Enter the link into your browser.

The full manual is available for immediate download.

**<https://www.ebooklibonline.com>**

<b>1.10 Maintenance</b> .....	<b>1-32</b>
1.10.1 General maintenance information .....	1-32
1.10.2 Fire prevention and first aid .....	1-33
1.10.3 High pressure leaks .....	1-34
1.10.4 Engine safety .....	1-35
1.10.5 Battery safety .....	1-36
1.10.6 Tire safety .....	1-37
1.10.7 Replacement parts .....	1-38
<b>2 Engine, Fuel And Exhaust System</b> .....	<b>2-1</b>
<b>2.1 Electronic diagnostic tool</b> .....	<b>2-3</b>
2.1.1 Engine service tool software license .....	2-3
2.1.2 Connecting the electronic diagnostic tool .....	2-3
<b>2.2 Component Access</b> .....	<b>2-4</b>
2.2.1 Opening the engine cover .....	2-4
2.2.2 Closing the engine cover .....	2-4
<b>2.3 Removing the engine</b> .....	<b>2-5</b>
<b>2.4 Installing the engine</b> .....	<b>2-13</b>
<b>2.5 Radiator</b> .....	<b>2-18</b>
<b>2.6 Air cleaner system</b> .....	<b>2-20</b>
<b>2.7 Fuel tank</b> .....	<b>2-22</b>
2.7.1 Fuel filters .....	2-22
2.7.2 Draining water from the fuel filter .....	2-22
2.7.3 Replacing the fuel filter .....	2-23
2.7.4 Bleeding the fuel system .....	2-24
2.7.5 Fuel tank .....	2-24
2.7.6 Removing the fuel tank .....	2-27
<b>2.8 Engine service manual</b> .....	<b>2-29</b>
2.8.1 Insert the engine service manual here .....	2-29
<b>2.9 Diagnostic troubleshooting codes and procedures</b> .....	<b>2-30</b>
2.9.1 Insert the diagnostic troubleshooting codes and procedures here .....	2-30
<b>3 Drive Train System</b> .....	<b>3-1</b>
<b>3.1 Transmission</b> .....	<b>3-3</b>
3.1.1 Separating the engine from the front transmission .....	3-3
3.1.2 Separating the front and mid transimission housings .....	3-7
3.1.3 Separating the mid and rear transimission housings .....	3-9
3.1.4 Separating the front and rear transmission housings .....	3-11
3.1.5 Installing the front transmission housing .....	3-21
3.1.6 Assembling the transmission housings .....	3-24
3.1.7 Removing the lift cylinder housing .....	3-25
3.1.8 Separating the rear axle from the rear transmission housing .....	3-30
3.1.9 Assembling the rear axle and the rear transmission housing .....	3-33
3.1.10 Transmission structure .....	3-34
3.1.11 Transmission components .....	3-35
3.1.12 Forward and reverse gear layout .....	3-35
3.1.13 Forward and reverse gear assembly precautions .....	3-36
<b>3.2 Clutch system</b> .....	<b>3-37</b>
3.2.1 Clutch dimensions .....	3-37
3.2.2 Removing the clutch .....	3-38
3.2.3 Inspecting the clutch disc .....	3-39
3.2.4 Inspecting the pressure plate assembly .....	3-40
3.2.5 Clutch housing vent hose .....	3-40
<b>3.3 Release bearing</b> .....	<b>3-41</b>
3.3.1 Removing the release bearing .....	3-41
3.3.2 Inspecting the release bearing .....	3-41

---

3.3.3	Installing the release bearing . . . . .	3-41
<b>3.4</b>	<b>Clutch assembly . . . . .</b>	<b>3-42</b>
3.4.1	Removing the clutch assembly . . . . .	3-42
3.4.2	Installing the clutch assembly . . . . .	3-42
3.4.3	Adjusting the clutch pedal . . . . .	3-44
3.4.4	Clutch housing plug . . . . .	3-44
<b>3.5</b>	<b>Troubleshooting - clutch . . . . .</b>	<b>3-45</b>
<b>3.6</b>	<b>Clutch pack and gear . . . . .</b>	<b>3-46</b>
3.6.1	Clutch pack components . . . . .	3-46
3.6.2	Disassembling the reverse clutch . . . . .	3-46
3.6.3	Forward and reverse gear components . . . . .	3-47
3.6.4	Main change gears . . . . .	3-48
3.6.5	Assembling the main change gear precautions . . . . .	3-48
3.6.6	Main shift lever . . . . .	3-49
3.6.7	Assembling the main shift lever precautions . . . . .	3-49
3.6.8	Range change gears . . . . .	3-49
3.6.9	Assembling the range change gears . . . . .	3-50
3.6.10	Shift linkage . . . . .	3-51
3.6.11	Lever linkage . . . . .	3-52
<b>3.7</b>	<b>Input gears . . . . .</b>	<b>3-54</b>
3.7.1	Disassembling the input gear . . . . .	3-54
3.7.2	Power take-off gear system . . . . .	3-60
3.7.3	Main gear assembly . . . . .	3-63
3.7.4	Assembling the input gear . . . . .	3-65
<b>3.8</b>	<b>Power take-off . . . . .</b>	<b>3-67</b>
3.8.1	Removing the input cover . . . . .	3-67
3.8.2	Rear power take-off assembly . . . . .	3-68
3.8.3	Disassembling the power take-off clutch pack . . . . .	3-69
3.8.4	Assembling the power take-off precautions . . . . .	3-70
3.8.5	Assembling precautions for the power take-off shaft . . . . .	3-71
<b>3.9</b>	<b>Four-wheel drive gears . . . . .</b>	<b>3-72</b>
3.9.1	Assembling the four-wheel drive . . . . .	3-73
<b>3.10</b>	<b>Hydrostatic transmission . . . . .</b>	<b>3-75</b>
3.10.1	Hydrostatic controls . . . . .	3-75
3.10.2	Hydrostatic transmission layout . . . . .	3-76
3.10.3	Change lever assembly . . . . .	3-77
3.10.4	Hydrostatic transmission pedal . . . . .	3-78
3.10.5	Adjusting the hydrostatic transmission pedal . . . . .	3-79
3.10.6	Hydrostatic transmission system . . . . .	3-80
3.10.7	Hydrostatic transmission damper input system . . . . .	3-80
3.10.8	Hydrostatic transmission component overview . . . . .	3-81
3.10.9	Hydrostatic transmission control unit . . . . .	3-82
3.10.10	Hydrostatic transmission hydraulic diagram . . . . .	3-83
3.10.11	Removing the hydrostatic transmission unit . . . . .	3-84
3.10.12	Disassembling the hydrostatic transmission unit . . . . .	3-86
3.10.13	Inspecting the hydrostatic transmission unit . . . . .	3-97
3.10.14	Assembling the hydrostatic transmission unit . . . . .	3-98
3.10.15	Installing the hydrostatic transmission unit . . . . .	3-112
3.10.16	Adjusting the auto cruise system . . . . .	3-113
<b>4</b>	<b>Platform . . . . .</b>	<b>4-1</b>
<b>4.1</b>	<b>Platform . . . . .</b>	<b>4-3</b>
4.1.1	Front floor system . . . . .	4-3
4.1.2	Rear floor system . . . . .	4-3
4.1.3	Removing the fender . . . . .	4-5
4.1.4	Fender . . . . .	4-6
4.1.5	Installing the fender . . . . .	4-7

---

4.1.6	Floor mat and steps . . . . .	4-8
4.1.7	Seat . . . . .	4-9
4.1.8	Checking the seat switch . . . . .	4-9
4.1.9	Front grill head lamp . . . . .	4-11
<b>4.2</b>	<b>Console . . . . .</b>	<b>4-12</b>
4.2.1	Removing the console . . . . .	4-12
4.2.2	Installing the console . . . . .	4-14
<b>4.3</b>	<b>Roll over protective structure . . . . .</b>	<b>4-16</b>
4.3.1	Removing the Roll Over Protective Structure . . . . .	4-16
4.3.2	Installing the Roll Over Protective Structure . . . . .	4-16
<b>4.4</b>	<b>Steering wheel . . . . .</b>	<b>4-18</b>
4.4.1	Removing the steering wheel . . . . .	4-18
4.4.2	Installing the steering wheel . . . . .	4-18
<b>5</b>	<b>Axles . . . . .</b>	<b>5-1</b>
<b>5.1</b>	<b>Rear axle . . . . .</b>	<b>5-3</b>
5.1.1	Three-point linkage . . . . .	5-3
5.1.2	Rear axle assembly guidelines . . . . .	5-5
5.1.3	Rear axle information . . . . .	5-6
5.1.4	Rear axle view . . . . .	5-6
5.1.5	Special tools . . . . .	5-7
<b>5.2</b>	<b>Differential lock . . . . .</b>	<b>5-8</b>
5.2.1	Differential lock system . . . . .	5-8
5.2.2	Disassembling the rear differential . . . . .	5-9
5.2.3	Assembling the rear differential . . . . .	5-10
5.2.4	Hydrostatic transmission settings . . . . .	5-12
5.2.5	Disassembling the rear axle differential lock and brake . . . . .	5-13
<b>5.3</b>	<b>Ring gear and pinion gear tooth pattern . . . . .</b>	<b>5-16</b>
<b>5.4</b>	<b>Front axle . . . . .</b>	<b>5-18</b>
5.4.1	Removing the front axle . . . . .	5-18
5.4.2	Installing the front axle . . . . .	5-19
5.4.3	General information - front axle . . . . .	5-20
5.4.4	Front axle construction . . . . .	5-20
5.4.5	Specifications - front axle . . . . .	5-22
5.4.6	Front wheel drive shaft - 4WD . . . . .	5-23
5.4.7	Front axle components . . . . .	5-24
5.4.8	Inspecting the front axle . . . . .	5-26
5.4.9	Front axle hydraulics . . . . .	5-28
5.4.10	Assembling the front axle . . . . .	5-29
5.4.11	Disassembling the pinion carrier assembly . . . . .	5-29
5.4.12	Inspecting the pinion carrier assembly . . . . .	5-30
5.4.13	Assembling the pinion carrier assembly . . . . .	5-30
5.4.14	Disassembling the differential gears . . . . .	5-32
5.4.15	Assembling the differential gears . . . . .	5-33
5.4.16	Final drive wheel components . . . . .	5-34
5.4.17	Removing the wheel shaft seal/cover . . . . .	5-34
5.4.18	Installing the wheel shaft seal/cover . . . . .	5-35
5.4.19	Removing the front axle center section . . . . .	5-36
5.4.20	Installing the front axle center section . . . . .	5-37
5.4.21	Removing the front axle housing oil seal . . . . .	5-37
5.4.22	Installing the front axle housing oil seal . . . . .	5-37
5.4.23	Disassembling the final drive housing . . . . .	5-38
5.4.24	Inspecting the bearing cover shaft . . . . .	5-39
5.4.25	Inspecting the drag arm bushing . . . . .	5-40
5.4.26	Inspecting the final drive housing shaft . . . . .	5-40
5.4.27	Assembling the final drive housing . . . . .	5-40
5.4.28	Front axle assembly . . . . .	5-42

---

5.4.29	Adjusting the front wheel alignment	5-44
5.4.30	Steering free play	5-45
5.4.31	Front axle troubleshooting	5-45
<b>6</b>	<b>Brake System</b>	<b>6-1</b>
6.1	<b>Brakes</b>	<b>6-3</b>
6.1.1	Brake system	6-3
6.1.2	Brake information	6-4
6.1.3	Checking the brake adjustment	6-5
6.1.4	Adjusting the brakes	6-5
6.1.5	Inspecting the brake discs and the separator plates	6-6
6.1.6	Brake disc wear limit	6-7
6.1.7	Separator plate wear limit	6-7
6.1.8	Brake troubleshooting	6-7
<b>7</b>	<b>Electrical System</b>	<b>7-1</b>
7.1	<b>Wiring diagrams</b>	<b>7-3</b>
7.1.1	Wire color chart	7-3
7.1.2	Vehicle wiring diagram	7-5
7.1.3	Engine wiring diagram	7-7
7.2	<b>Wiring harness</b>	<b>7-9</b>
7.2.1	Wiring harness layout	7-9
7.3	<b>Fuses, relays, and diodes</b>	<b>7-12</b>
7.3.1	Main fuse box	7-12
7.3.2	Relay locations	7-12
7.3.3	Diode location	7-13
7.4	<b>Instruments and controls</b>	<b>7-15</b>
7.4.1	Instrument panel components	7-15
7.4.2	Indicators and gauges	7-15
7.4.3	Instrument panel indicator inputs	7-18
7.4.4	Instrument panel connection	7-20
7.4.5	Removing the instrument panel	7-21
7.4.6	Installing the instrument panel	7-21
7.4.7	Instrument panel layout	7-21
7.4.8	Handling the engine control unit	7-22
7.5	<b>Switches</b>	<b>7-23</b>
7.5.1	Neutral start safety switches	7-23
7.5.2	Combination switch	7-26
7.5.3	Start switch	7-26
7.5.4	Adjusting the seat switch	7-27
7.5.5	Power takeoff switch	7-27
7.6	<b>Sensors</b>	<b>7-30</b>
7.6.1	Throttle position sensor	7-30
7.6.2	Fuel gauge sender	7-30
7.7	<b>Electronic diagnostic tool</b>	<b>7-31</b>
7.7.1	Engine service tool software license	7-31
7.7.2	Connecting the electronic diagnostic tool	7-31
<b>8</b>	<b>Hydraulic System</b>	<b>8-1</b>
8.1	<b>Hydraulic system overview</b>	<b>8-3</b>
8.2	Hydraulic schematic	0
8.3	<b>Power shuttle components</b>	<b>8-4</b>
8.4	<b>General service procedures</b>	<b>8-9</b>
8.4.1	Changing the hydraulic oil	8-9
8.4.2	Oil cooler and the main clutch lubrication	8-10
8.5	<b>Suction filter</b>	<b>8-12</b>

---

<b>8.6 Gear pump</b> .....	<b>8-14</b>
8.6.1 Main pump .....	8-14
8.6.2 Sub pump .....	8-15
8.6.3 Power steering cylinder .....	8-16
8.6.4 Main cylinder .....	8-18
<b>8.7 Valves</b> .....	<b>8-20</b>
8.7.1 Main relief valve .....	8-20
8.7.2 Steering orbit roll .....	8-23
8.7.3 Slow return valve .....	8-24
8.7.4 Assembling the slow return valve precautions .....	8-24
8.7.5 Safety valve .....	8-25
8.7.6 Assembling the slow return valve precautions .....	8-25
8.7.7 Power takeoff control valve .....	8-26
8.7.8 Assembling the power take-off control valve precautions .....	8-27
8.7.9 Assembling precautions for the reduce valve .....	8-27
8.7.10 Reduce valve specifications .....	8-27
8.7.11 External auxiliary hydraulics .....	8-27
8.7.12 Auxiliary control valve .....	8-29
8.7.13 Disassembling the auxiliary control valve .....	8-31
8.7.14 Assembling the auxiliary control valve .....	8-31
8.7.15 Removing the auxiliary control valve .....	8-32
8.7.16 Installing the auxiliary control valve .....	8-32
8.7.17 Auxiliary hydraulics outlet .....	8-32
8.7.18 Removing the external hydraulic pressure .....	8-34
<b>8.8 Hydraulic control linkage</b> .....	<b>8-36</b>
8.8.1 Position control link and lever .....	8-36
8.8.2 Adjusting the position control lever .....	8-37
8.8.3 Position control lever operation .....	8-37
8.8.4 Draft control link and lever, if equipped .....	8-38
8.8.5 Adjusting the draft control, if equipped .....	8-38
<b>8.9 Three-point lift linkage and drawbar</b> .....	<b>8-40</b>
8.9.1 Three-point linkage .....	8-40
8.9.2 Drawbar dimensions .....	8-42
<b>8.10 Hydraulic system troubleshooting</b> .....	<b>8-43</b>
8.10.1 Testing the power takeoff clutch pack pressure .....	8-47
<b>9 Steering System</b> .....	<b>9-1</b>
<b>9.1 Hydrostatic steering</b> .....	<b>9-3</b>
9.1.1 Hydrostatic steering components .....	9-3
9.1.2 Integral orbit roll components .....	9-4
9.1.3 Disassembling the steering unit .....	9-5
9.1.4 Inspecting the steering unit .....	9-8
9.1.5 Assembling the control side of the steering unit .....	9-8
9.1.6 Assembling the gerotor side of the steering unit .....	9-10
9.1.7 Flow control valve .....	9-12
9.1.8 Steering system troubleshooting .....	9-13
<b>10 Index</b> .....	<b>Index-1</b>

# 1. General

<b>1.1 Introduction</b>	<b>1-3</b>
1.1.1 The service manual	1-3
1.1.2 Replacement parts	1-3
1.1.3 Units of measurement	1-3
1.1.4 Serial number plate	1-3
1.1.5 Engine identification	1-4
1.1.6 Chassis number	1-5
<b>1.2 Specifications</b>	<b>1-6</b>
1.2.1 Engine specifications	1-6
1.2.2 Electrical specifications	1-7
1.2.3 Power take-off specifications	1-7
1.2.4 Mechanical transmission specifications	1-7
1.2.5 Hydrostatic transmission specifications	1-7
1.2.6 Power take-off specifications	1-8
1.2.7 Hydraulic specifications	1-8
1.2.8 Fuel specifications	1-8
1.2.9 Operating slope angle	1-9
1.2.10 Capacities	1-9
1.2.11 Lubrication specifications	1-9
1.2.12 Tire inflation pressures	1-9
1.2.13 Maximum load capacity	1-10
<b>1.3 General dimensions</b>	<b>1-11</b>
1.3.1 Dimensions	1-11
1.3.2 Major components	1-12
<b>1.4 Lubrication / fill points</b>	<b>1-13</b>
1.4.1 Lubrication and maintenance chart	1-13
1.4.2 Lubrication fill and drain locations - mechanical	1-14
1.4.3 Lubrication fill and drain locations - hydrostatic	1-15
<b>1.5 General precautions for disassembly and installation</b>	<b>1-16</b>
1.5.1 Precautions for disassembling and installing	1-16
1.5.2 Precautions when installing according to standard parts	1-16
<b>1.6 Tightening torque chart</b>	<b>1-19</b>
<b>1.7 Conversion table</b>	<b>1-21</b>
<b>1.8 Safety introduction</b>	<b>1-22</b>
1.8.1 Safety alert symbol	1-22
1.8.2 Safety messages	1-22
1.8.3 Informational messages	1-22
1.8.4 Safety signs	1-22
<b>1.9 Operation</b>	<b>1-24</b>
1.9.1 Prepare for operation	1-24
1.9.2 Roll over protective structure	1-24
1.9.3 General information	1-24
1.9.4 Personal protective equipment	1-28
1.9.5 Seat instruction	1-28
1.9.6 Shield and guards	1-28
1.9.7 Power take-off safety	1-29
1.9.8 Exhaust warning	1-30
1.9.9 Agricultural chemicals	1-30
1.9.10 Travel on public roads	1-30



---

<b>1.10 Maintenance</b> .....	1-32
1.10.1 General maintenance information .....	1-32
1.10.2 Fire prevention and first aid .....	1-33
1.10.3 High pressure leaks .....	1-34
1.10.4 Engine safety .....	1-35
1.10.5 Battery safety .....	1-36
1.10.6 Tire safety .....	1-37
1.10.7 Replacement parts .....	1-38

## 1.1 Introduction

### 1.1.1 The service manual

Read the table of contents and basic layout. Become familiar with all parts of this service manual. This service manual gives the technician very important information.

Machine movement when in normal use determines right-hand and left-hand.

This manual covers general safety practices for this machine.

The photos, illustrations, and data used in this manual were current at the time of printing. Inline production changes can make machines vary from the information in the service manual. The manufacturer reserves the right to redesign and change the machine as necessary without notification.



**WARNING:**

**In some of the illustrations and photos used in this manual, shields or guards may have been removed for clarity. Never operate the machine with any shields or guards removed. If the removal of shields or guards is necessary to make a repair, they must be replaced before operation.**

### 1.1.2 Replacement parts

To receive prompt efficient service, remember to have the following information:

- Correct part description and part number
- Model number of the machine
- Serial number of the machine

### 1.1.3 Units of measurement

Measurements are given in metric units followed by the equivalent in US units. Hardware sizes are given in millimeters for metric hardware and inches for US hardware.

### 1.1.4 Serial number plate

The serial number plate (1) is located below the operator seat.

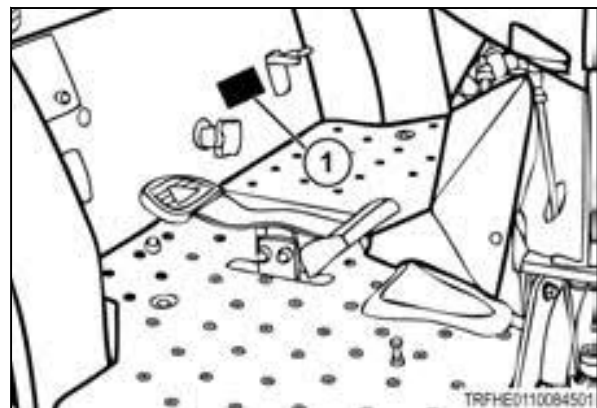

Fig. 1

1. General

The serial number plate contains the model number and serial number.

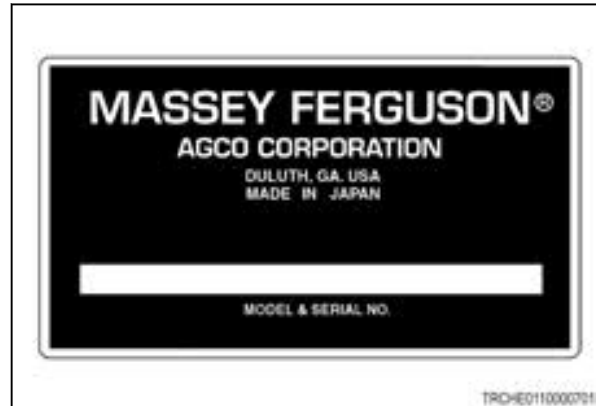

Fig. 2

1.1.5 Engine identification

The engine identification plate (1) is located on the left-hand side of the engine.



Fig. 3

The engine identification plate contains the engine model number (1), the engine serial number (2), and the month(s)/year(s) (3) the engine was assembled.

Engine model number:	
Engine serial number:	
Assembled month(s)/year(s):	

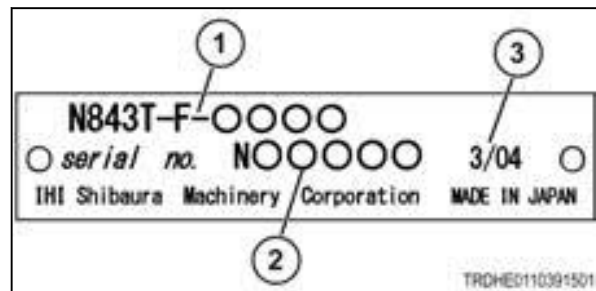

Fig. 4

### 1.1.6 Chassis number

The chassis number (1) is stamped in right-hand side of the front frame.

Chassis number:	
-----------------	--

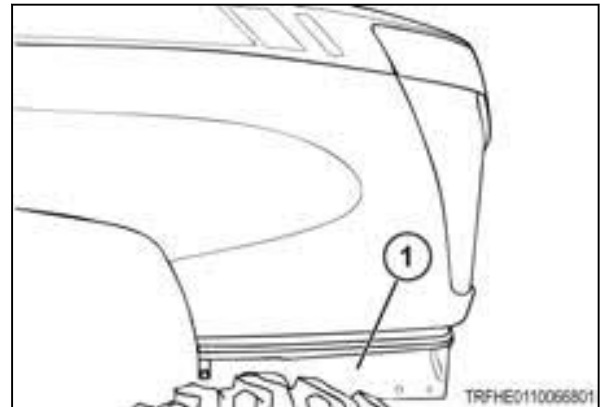

Fig. 5

## 1.2 Specifications

### 1.2.1 Engine specifications

	2705E mechanical	2705E hydrostatic	2706E mechanical	2706E hydrostatic
Type	Water-cooled, in-line overhead valve, turbocharged diesel			
Model	N4LDI-T		N4LDI-TA	
Make	IHI SHIBAURA Machinery Corporation			
Number of cylinders	4			
Combustion system	In-direct injection system			
Compression ratio	18.0			
Injection	Inline injection pump			
Bore	84 mm (3.31 in)			
Stroke	100 mm (3.94 in)			
Displacement	2216 cm <sup>3</sup> (135.23 in <sup>3</sup> )			
Rated speed	2600 rpm			
Low idle speed	975 to 1025 rpm			
High idle speed	2705 to 2755 rpm			
Maximum torque at rpm	160 Nm (118 lbf ft) @ 1600 rpm	192 Nm 141.6 lbf ft) @ 1600 rpm	160 Nm (118 lbf ft) @ 1600 rpm	192 Nm 141.6 lbf ft) @ 1600 rpm
Engine horse power (estimated gross)	36.4 kW (48.8 hp) @ 2600 rpm		42.7 kW (57.3 hp) @ 2600 rpm	
PTO horse power (estimated)	30.9 kW (41.4 hp) @ 578 rpm	29.1 kW (39.0 hp) @ 578 rpm	36.3 kW (48.7 hp) @ 578 rpm	34.2 kW (45.9 hp) @ 578 rpm
Engine cooling	Water cooling			
Fan	430 mm (16.93 in)/ 8 blades			
Air cleaner	Dual stage, dry element			
Air intake	Engine cover grille			
Cold starting aid	Glow plug			
Firing order	1-3-4-2			
Valve clearance (cold) - intake and exhaust	0.2 mm (0.008 in)			

## 1.2.2 Electrical specifications

	2705E mechanical	2705E hydrostatic	2706E mechanical	2706E hydrostatic
System voltage	12 volt			
Grounding	Negative			
Battery cold cranking amperage @ 18° C (64° F)	680 cca			
Battery JIS type	115D31R			
Battery holder	Length: 305 mm (12 in) Width: 172 mm (6.8 in) Height: 200 mm (7.9 in)			
Alternator rating	90 ampere			
Starter rating	12 volt / 2.0 kW (2.7 hp)			

## 1.2.3 Power take-off specifications

	2705E mechanical	2705E hydrostatic	2706E mechanical	2706E hydrostatic
Type	Engine driven			
Control	PTO selector switch			
Clutch	PTO over-running clutch			
PTO shaft type	35 mm (1.38 in) diameter, 6 spline			
Output	Clockwise rotation			

## 1.2.4 Mechanical transmission specifications

	2705E mechanical	2706E mechanical
Primary transmission	Gear type	
Range transmission	2-speed range	
Gear speeds	8 gears (forward, reverse)	
Clutch	Single stage dry type	

## 1.2.5 Hydrostatic transmission specifications

	2705E hydrostatic	2706E hydrostatic
Primary transmission	HST, gear	
Range transmission	3-speed range	
Gear speeds		
Clutch	None	

### 1.2.6 Power take-off specifications

	2705E mechanical	2705E hydrostatic	2706E mechanical	2706E hydrostatic
Type	Engine driven			
Control	PTO selector switch			
Clutch	PTO over-running clutch			
PTO shaft type	35 mm (1.38 in) diameter, 6 spline			
Output	Clockwise rotation			

### 1.2.7 Hydraulic specifications

	2705E mechanical	2705E hydrostatic	2706E mechanical	2706E hydrostatic
<b>Main hydraulic system</b>				
Pump	Transmission mounted			
Maximum output	47.8 l/min (12.6 gal/min (US))			
Pressure	16.18 mPa (2346.8 psi)			
<b>Steering system</b>				
Type	Hydrostatic			
Pump	Transmission mounted			
Maximum output	26.5 l/min (7 gal/min (US)) @ 2600 rpm			
Pressure	Relief valve setting 11.77 mPa (1706.8 psi)			
<b>Rear linkage</b>				
Type	Three-point hitch			
Size	Category I and II			
Control	Operated by single position control lever			
Relief valve setting	15.7 mPa (2275.7 psi)			
<b>Lift Capacity</b>				
Measured at ball ends	1200 kg (2645 lb)			
Measured at 610 mm (24 in)	1100 kg (2425 lb)			

### 1.2.8 Fuel specifications

	2705E mechanical	2705E hydrostatic	2706E mechanical	2706E hydrostatic
Type	Ultra low Sulfur fuel only			
Above 4 °C (39 °F)	No. 2-D			
Below 4 °C (39 °F)	No. 1-D			

### 1.2.9 Operating slope angle

	2705E mechanical	2705E hydrostatic	2706E mechanical	2706E hydrostatic
Up/down	20 degrees			
Side to side	20 degrees			

### 1.2.10 Capacities

	2705E mechanical	2705E hydrostatic	2706E mechanical	2706E hydrostatic
Fuel tank	53.0 L (14 gal (US))			
Engine crankcase with filter	5.8 L (1.53 gal (US))			
Cooling system	6.3 L (1.66 gal (US))			
Reserve tank	1.0 L (0.26 gal (US))			
Hydraulic system	38.0 L (10.04 gal (US))			
Front drive axle	8.5 L (2.21 gal (US))			

### 1.2.11 Lubrication specifications

	2705E mechanical	2705E hydrostatic	2706E mechanical	2706E hydrostatic
Lubrication fitting	Massey Ferguson M-1105 or equivalent lithium base grease No. 2			
Engine oil	Massey Ferguson Multiguard® or equivalent in the correct SAE viscosity. Oil must meet or exceed requirements API service classification CJ-4 class			
<b>Recommended Viscosity:</b>				
Between -10 and 40 °C (5 to 104 °F)	SAE10W-30			
Between -20 to 40 °C (-4 to 104 °F)	SAE0W-30 / SAE5W-30			
0 °C (32 °F) and above	SAE15W-40 / SAE20W-40			
Engine coolant	50/50 mixture ethylene glycol and water			
Freezing protection (original factory fill)	-34 °C (-29 °F)			
Transmission and differential housing (including hydraulic system)	AGCO Permatran 821XL			
Front axle	AGCO Permatran 821XL			

### 1.2.12 Tire inflation pressures

Tire type	Tire location	Tire size	Pressure
Ag	Front	9.5-16-6	207 kPa (30 psi)
	Rear	13.6-28-6	152 kPa (22 psi)
Ag	Front	9.5-16-6	207 kPa (30 psi)

Tire type	Tire location	Tire size	Pressure
	Rear	16.9-24-6	124 kPa (18 psi)
Turf	Front	27x10.50-15-4	207 kPa (30 psi)
	Rear	44x18.00-20-4	138 kPa (20 psi)
R4	Front	10-16.5NHS-6	310 kPa (45 psi)
	Rear	17.5L-24-6	138 kPa (20 psi)

### 1.2.13 Maximum load capacity

	2705E mechanical	2705E hydrostatic	2706E mechanical	2706E hydrostatic
Front axle capacity	1000 kg (2205 lb)			
Rear axle capacity	1000 kg (2205 lb)			
Total capacity	2000 kg (4409 lb)			



**Suggest:**

**For more complete manuals. Please go to the home page.**

**<https://www.ebooklibonline.com>**

**If the above button click is invalid. Please download this document first, and then click the above link to download the complete manual.**

**Thank you so much for reading**

## 1.3 General dimensions

### 1.3.1 Dimensions

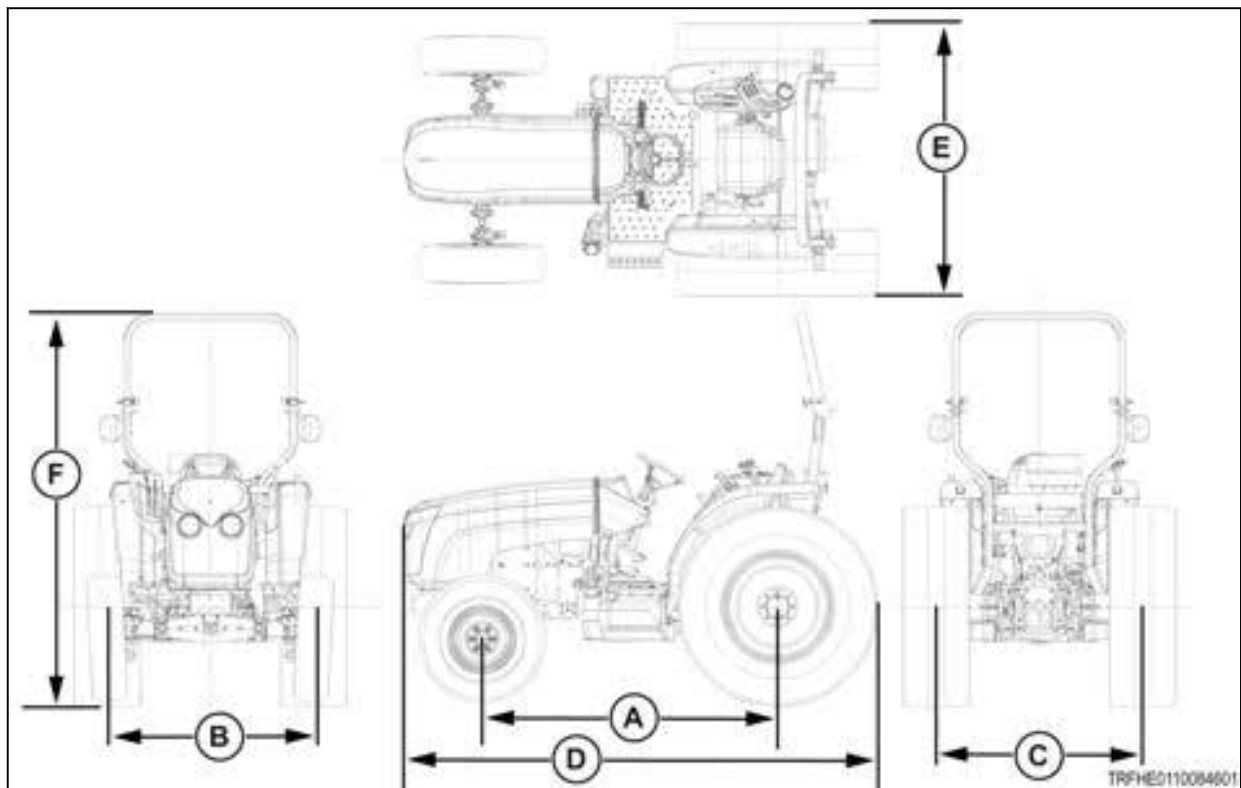

Fig. 6

		2705E	2706E
<b>Tire</b>		R1-2	
<b>Front</b>		9.5-16	
<b>Rear</b>		16.9-24	
A	Wheelbase	1980 mm (77.95 in)	
B	Front wheel tread	1340 mm (52.76 in)	
C	Rear wheel tread	1440 mm (56.69 in)	
D	Length	3370 mm (132.68 in)	
E	Width	1890 mm (74.41 in)	
F	Height	2645 mm (104.13 in)	
Turning radius (with brake)		2.5 m (98.42 in)	
Turning radius (without brake)		2.9 m (114.17 in)	
Ground clearance		380 mm (14.96 in)	
<b>Weight</b>			
Mechanical transmission		1740 kg ( lb)	
Hydrostatic transmission		1760 kg ( lb)	

### 1.3.2 Major components

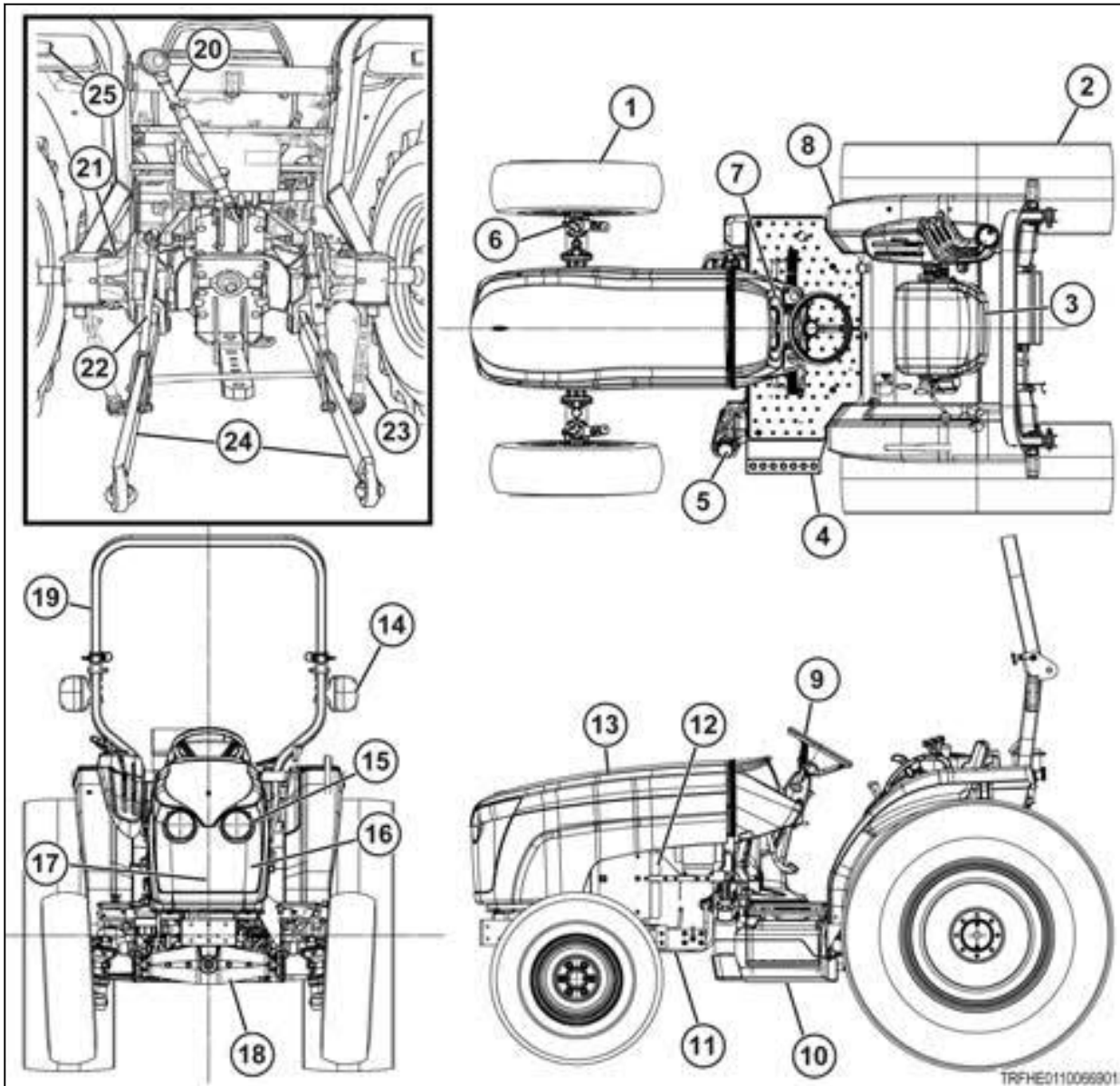

Fig. 7

- |                              |  |
|------------------------------|--|
| (1) Front wheel              | (14) Turn/hazard lamp                      |
| (2) Rear wheel               | (15) Head lamp                             |
| (3) Operator's seat          | (16) Front grill                           |
| (4) Foot step                | (17) Battery                               |
| (5) Fuel tank filler         | (18) Front axle                            |
| (6) Steering cylinder        | (19) Roll over protective structure (ROPS) |
| (7) Instrument panel         | (20) Lift arm                              |
| (8) Fender                   | (21) Rear axle                             |
| (9) Steering wheel           | (22) Lift rod                              |
| (10) Transmission            | (23) Stabilizer                            |
| (11) Front wheel drive shaft | (24) Lower links                           |
| (12) Engine                  | (25) Reflector                             |
| (13) Engine cover            |  |

**<https://www.ebooklibonline.com>**

Hello dear friend!

Thank you very much for reading.

Enter the link into your browser.

The full manual is available for immediate download.

**<https://www.ebooklibonline.com>**