



MASSEY FERGUSON

MF 1800

Small Square Baler

Models: 1836 / 1838 / 1840



SERVICE MANUAL

FROM MASSEY FERGUSON

Massey Ferguson®

1836 / 1838 / 1840
Small Square Baler

SERVICE MANUAL 4283565M1

CONTENTS

GENERAL INFORMATION	01
ADJUSTMENTS.....	02
DRIVE LINE.....	03
PICKUP.....	04
HYDRAULICS	05
KNOTTER.....	06
MAINFRAME	07
TROUBLESHOOTING	08
SPECIFICATIONS	09
INDEX	10

NOTES

<https://www.ebooklibonline.com>

Hello dear friend!

Thank you very much for reading.

Enter the link into your browser.

The full manual is available for immediate download.

<https://www.ebooklibonline.com>

Massey Ferguson®

**1836 / 1838 / 1840
Small Square Baler**

**SERVICE MANUAL
4283565M1**

01 - General Information

Contents

Introduction	01-3
Units of Measurement	01-3
Replacement Parts	01-3
Serial Number Definition	01-3
Serial Number Plate Location	01-4
Machine Identification	01-4
Model and Serial Numbers	01-4
Component Identification	01-5
Drive Train	01-6
Slip Clutches	01-7
Pickup and Feeding	01-8
Shearbolts	01-9
Location	01-9
Replacement	01-10
Roller Chains	01-11
Inspection of Drive Chains and Sprockets	01-11
Drive Chain Adjustment and Tightening	01-12
Drive Chain Sprocket and Idler Alignment	01-12
Drive Chain Elongation and Sprocket Wear	01-14
Normal Tooth Wear	01-14
Not Normal Tooth Wear	01-15
Worn Chain on New Sprockets	01-15
Drive Chain Service Tips	01-15
Chain Replacement	01-16
Cleaning and Lubricating Chains	01-17
Drive Chain Lubrication	01-17
Drive Chain Lubricants	01-18
Good Drive Chain Lubrication	01-18
Chain Speed Calculation Formulas	01-18
Geometrical Formulas	01-19
Circumference of a Circle	01-19
Area of a Circle	01-19
Volume of a Cylinder	01-19
Volume of a Sphere	01-19
Area of a Triangle	01-19
Metric to Imperial and Imperial to Metric Conversion Factors	01-19
Measures of Temperature	01-19
Measures of Power	01-19
Measures of Pressure	01-19
Measures of Length	01-19
Measures of Area	01-19
Measures of Volume (Dry)	01-20
Measures of Volume (Liquid)	01-20

Contents

Measures of Mass (Weight)	01-20
Measures of Effort (Torque)	01-21
Reference Tables	01-21
Metric Conversions	01-22
Fractions, Decimals, and Millimeters Conversion Chart	01-23
Decimal Equivalents of 8ths, 16ths, 32nds, and 64ths	01-28
Decimal Equivalents Of Letter Size Drills	01-28
Decimal Equivalents of Number Size Drills	01-29
American Standard Pipe Thread and Tap Drill Sizes	01-31
Sealed Bearings	01-31
Electrical	01-31
Wheel Bearings	01-31
Wheel Bolts	01-31
Bearing Replacement (Eccentric Self-Locking Collar)	01-32
Gib Key Removal And Installation	01-33
Service Chart	01-34
Grease Fittings	01-35
Metering Assembly and Needles	01-35
Knotter Assembly	01-36
IDL (Implement Driveline)	01-37
Baler Grease Fittings	01-38
Bale Thrower Option	01-40
Torque Charts	01-41
.....	01-41
Metric Capscrew Markings and Torque Values	01-42

GENERAL INFORMATION

INTRODUCTION

The operation and maintenance instructions included in this Service Manual are assembled from a large amount of field testing and other data. The information was written for typical conditions. Make adjustments as necessary for specific conditions.

Right-hand and left-hand, as used in this Service Manual, is determined by facing the direction the baler will travel when in use.

UNITS OF MEASUREMENT

Measurements are given in metric units of measurement followed by the equivalent in U.S. units. Hardware sizes are given in millimeters for metric hardware and inches for U.S. hardware.

REPLACEMENT PARTS

To receive efficient service, always remember to give your Massey Ferguson® Dealer the following information:

- Correct part description, or part number.
- Model number of your baler.
- Serial number of your baler.

SERIAL NUMBER DEFINITION

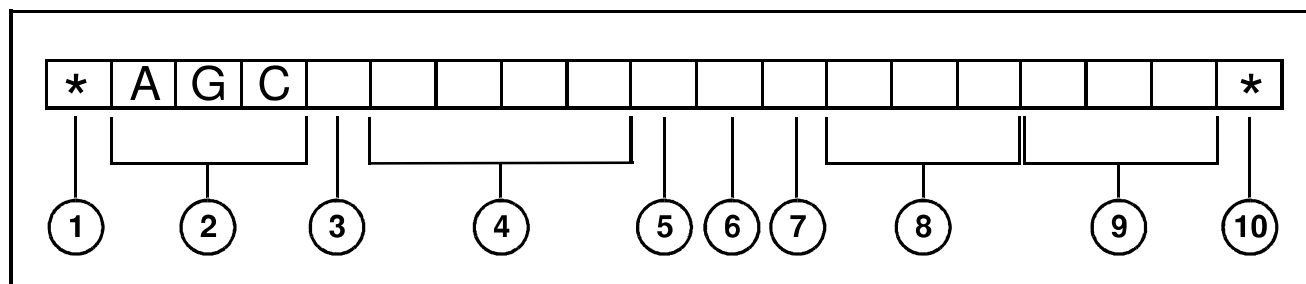

FIG. 1

FIG. 1: Definition of the serial number.

- (1) Beginning symbol
- (2) World Manufacturer Code
- (3) Brand Code
- (4) Model Identifier (Model number)
- (5) Check Letter (0 or used if model identifier is five digits)
- (6) Model Year Code (A=2010, B=2011, C=2012, and on)
- (7) Plant Code
- (8) Family Code
- (9) Unit Number for the Year
- (10) Ending symbol

General Information

NOTE: For serial number breaks in this manual, only the information from the model year code and following will be given.

SERIAL NUMBER PLATE LOCATION

FIG. 2: Each baler has a serial number plate (1) with the model and serial number. The serial number plate is located on the left-hand side of the front shield.



FIG. 2

MACHINE IDENTIFICATION

Model and Serial Numbers

NOTE: Any time your baler needs service, or parts, give your Massey Ferguson® Dealer the model and serial numbers.

Machine model No. _____

Machine serial No. _____

Date received: _____

COMPONENT IDENTIFICATION

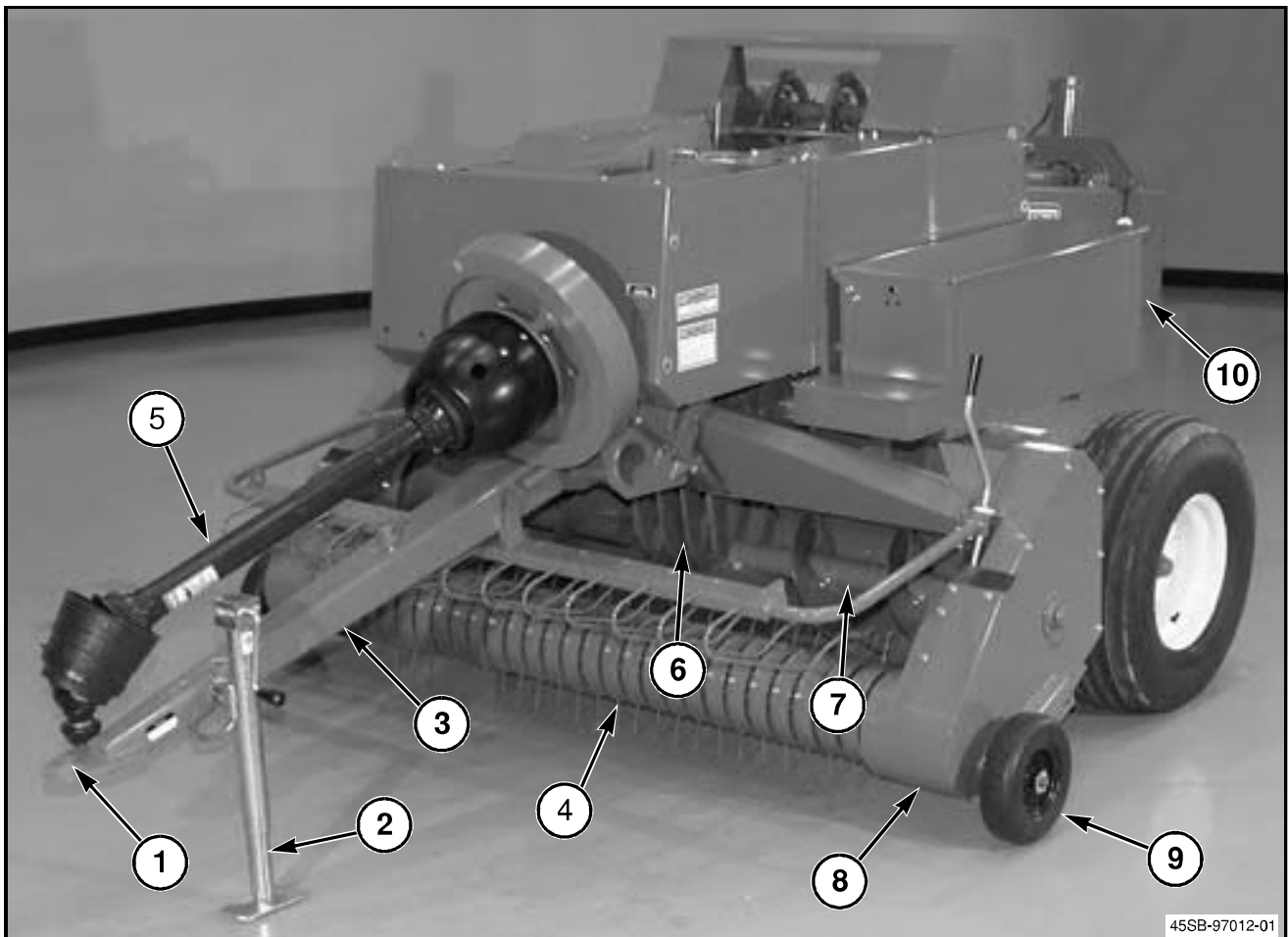

FIG. 3

FIG. 3: Front view

- (1) Hitch
- (2) Jack
- (3) Tongue
- (4) Pickup assembly
- (5) IDL (Implement Driveline)
- (6) Charge chamber
- (7) Auger (one on each side)
- (8) Left-hand auger drive chain cover
- (9) Gauge wheel (one on each side)
- (10) Bale chamber

General Information

DRIVE TRAIN

FIG. 4: The baler is driven by the tractor PTO system. The baler requires a standard 540 rev/min tractor PTO. The baler uses a four U-joint drive shaft between the tractor and the baler. The tractor power goes from the rear U-joint (1) of the drive shaft to the overrunning clutch (2).

The overrunning clutch permits the baler flywheel (3) to freewheel when the PTO is disengaged or the tractor engine speed is reduced. This permits the operator to change gears on the tractor without waiting for the flywheel to come to a complete stop.

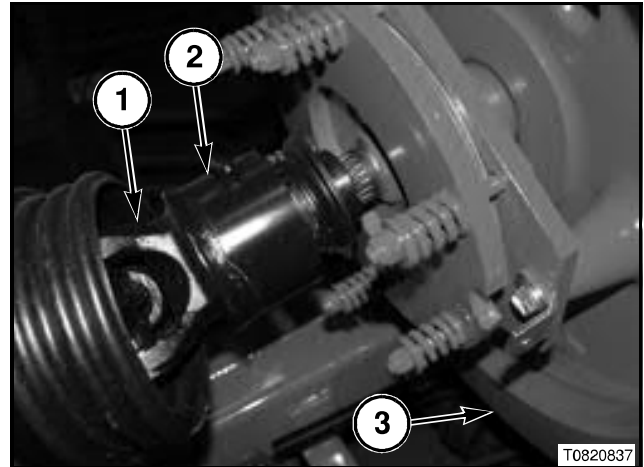

FIG. 4

FIG. 5: From the overrunning clutch, the power goes through a slip clutch (4), and the flywheel and flywheel shearbolt (5). The flywheel shearbolt drives the gearbox, which in turn operates the other baler mechanisms. The flywheel shearbolt also protects the other components.

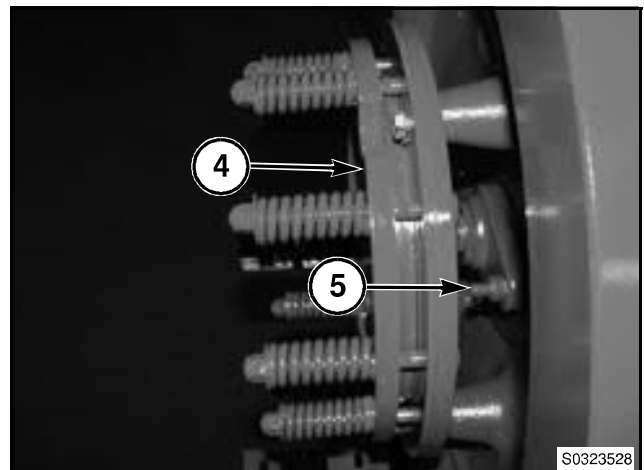

FIG. 5

FIG. 6: The crank arm on the right-hand side of the gearbox drives the plunger (1).

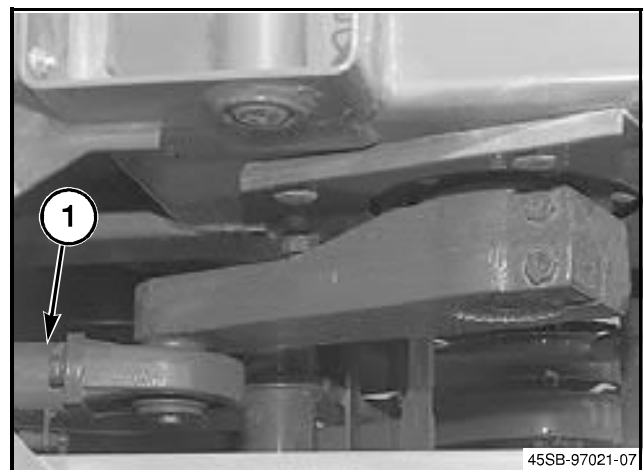

FIG. 6

FIG. 7: The sprocket (1) on the left-hand side of the gearbox drives the chain (2). The sprocket is protected by a shearbolt (3).

The chain drives the stuffer double sprocket (4) and the pickup drive shaft sprocket (5). The stuffer double sprocket drives a No. 50 chain (6). The pickup assembly is protected by a slip clutch.

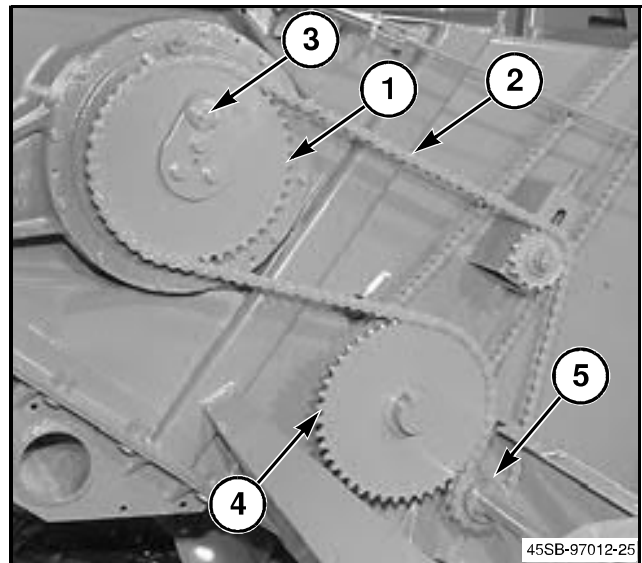

FIG. 7

FIG. 8: The No. 50 chain (1) drives the knotters (2), and the needles (3). These components are protected by a shearbolt (4).

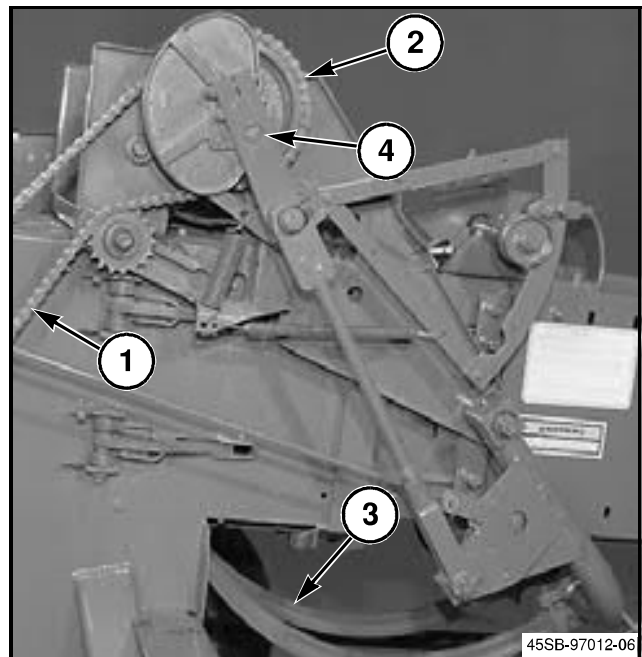

FIG. 8

SLIP CLUTCHES

Slip clutches are used at two locations to protect the baler's components against damage from overloads. The slip clutches use two fibrous clutch discs between steel pressure plates. Spring tension on the plates keeps the required torque.

The slip clutch on the front of the flywheel protects the tractor PTO from stresses caused by sudden overloads. The slip clutch on the pickup assembly drive protects the baler from slugs of hay that can jam the bale chamber or hard objects that can cause damage. The slip clutches must be checked and adjusted.

General Information

PICKUP AND FEEDING

FIG. 9: Continuous flow, straight through feeding is possible with the wide, low profile pickup assembly (1). Hay from the windrow is picked up by the closely located tines (2) of the pickup assembly and moved by an auger (3) into a charge chamber (4). The in line charge chamber feeds the baling chamber from the bottom.

This baler makes bales that are the same shape and the same condition in light, or heavy, windrows. As the flakes are formed, the stuffer fingers sweep the flakes into the bale chamber with each return stroke of the plunger. With the PTO operating at 540 rpm, the plunger makes 100 strokes per minute to compress the hay in the baling chamber.

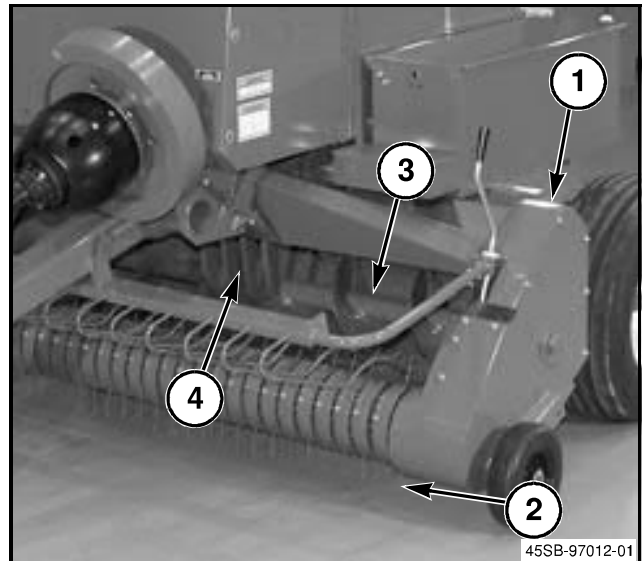

FIG. 9

FIG. 10: The pickup height adjustment strap (1) controls the height of the tines above the ground. Set tine height according to instructions in the Adjustments Section.

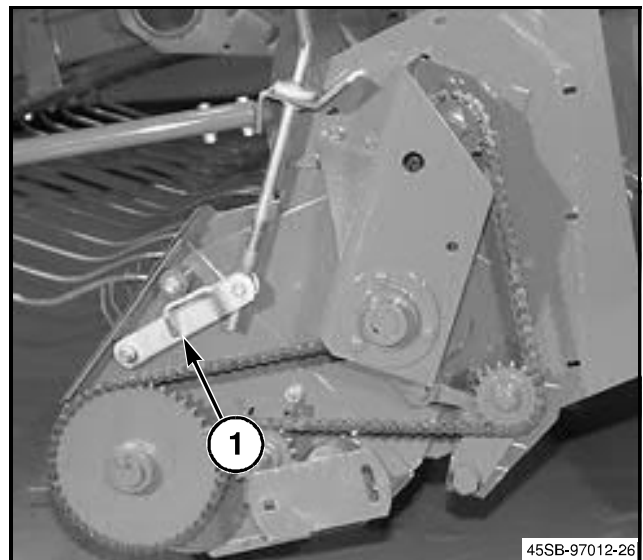

FIG. 10

SHEARBOLTS

Location

The shearbolts are used in three different locations to protect the components.

FIG. 11: The flywheel shearbolt (1) connects the flywheel to the other parts of the drive train. When the flywheel shearbolt breaks, the flywheel cannot drive the baler.

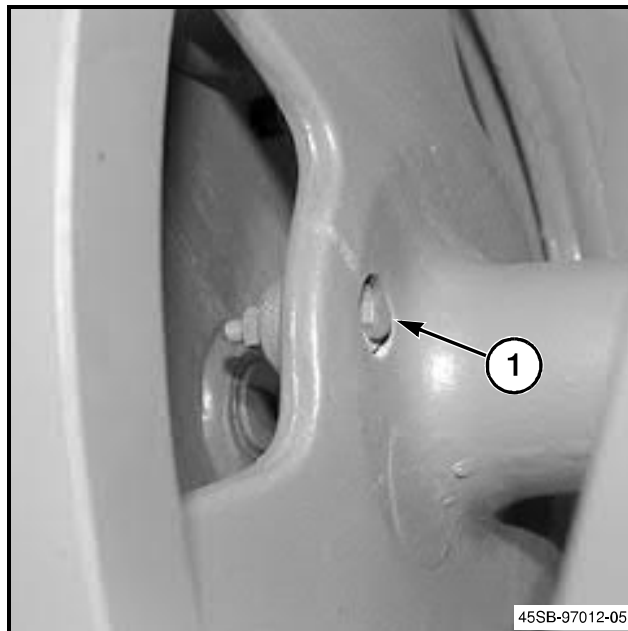

FIG. 11

FIG. 12: The twine knotter and needles are protected by a shearbolt (1) through the needle arm and reset cam.

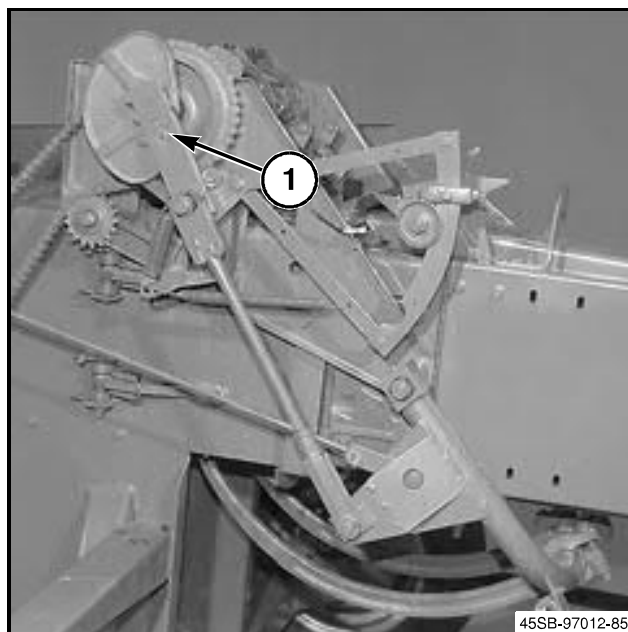

FIG. 12

General Information

FIG. 13: The stuffer / pickup drive shearbolt (1) drives the stuffer fingers and the pickup assembly.

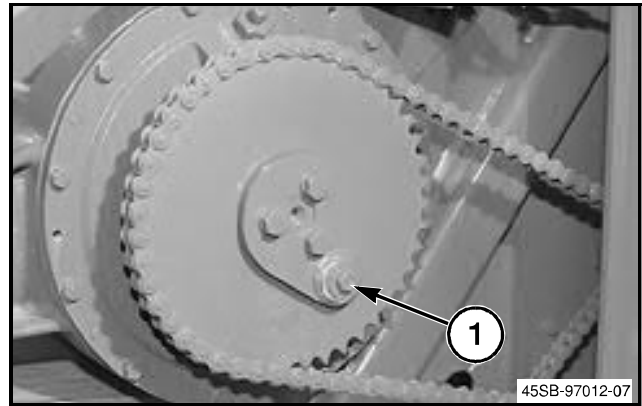

FIG. 13

Replacement

Stop the tractor and baler immediately when a shearbolt breaks. Determine what caused the shearbolt to shear.

If the flywheel shearbolt breaks and is replaced on a tying cycle, DO NOT rotate the flywheel in the reverse direction. Rotating the baler flywheel in the counterclockwise direction (facing the direction of baler travel) will reverse the baler. This can cause damage to the knotter trip arm when the knotter trip arm contacts the clutch dog.

NOTE: If the flywheel shearbolt breaks, check the stuffer and the knotter shearbolts too.

The knotter drive clutch, when engaged, is of a lock up type and will reverse the knotters if the baler is reversed. Trip the knotter trip arm to permit the clutch dog to pass the knotter trip arm without interference.

Always replace broken bolts with the correct bolt as called for in the manual. Do not replace the bolt with a higher strength bolt than specified. This can result in damage to the baler.

Always make sure all shearbolts are tight. Do not tighten shearbolts too much. Refer to the manual when replacing the shearbolts.

ROLLER CHAINS

Inspection of Drive Chains and Sprockets

Experience will determine how frequently drive chains will need to be inspected and serviced. Make a regular schedule and follow the schedule.

With new chains and sprockets some adjustment of the chain tension can be looked for during the first run-in period.

Inspect the chains and sprockets for the following:

1. Wear of the chain link side plates.
2. Wear on the sides of the sprocket teeth.
3. Alignment of the sprockets, idlers, and shafts.
4. Chain elongation.
5. Wear on the working faces of the sprocket teeth.

Check for interference between the drive and other parts of the equipment. If there is any interference, correct immediately. Interference can cause not normal and damaging wear on the chain and interference part. If the edges of the chain link plates hit against a rigid part, the link plate will become weak because of strain and a chain failure can result.

Check for and remove any deposit of debris or foreign material from between the chain and sprockets. A small amount of material in the sprocket roll seat can cause tensile loads large enough to break the chain if forced through the drive.

Inspect the chain for cracks, broken, or distorted parts. If any of these conditions are found, replace the complete chain. Even if the parts of the chain look in good condition, the complete chain has been damaged and must be replaced.



Suggest:

For more complete manuals. Please go to the home page.

<https://www.ebooklibonline.com>

If the above button click is invalid. Please download this document first, and then click the above link to download the complete manual.

Thank you so much for reading

General Information

Drive Chain Adjustment and Tightening

Proper adjustment and tightening is necessary for long drive chain service life.

Over tightening causes the drive chains to elongate and puts additional loading on the sprockets, shafts, and bearings.

Loose drive chains will climb on the sprocket teeth and cause excessive wear.

FIG. 14: To check drive chain tension, turn the drive sprocket in a direction that is opposite to the normal direction of rotation (to remove all the slack from the idler sprocket strand of the chain). Measure the slack at the middle point of the longest drive strand as shown.

As a general rule:

- Horizontal and inclined drive chains must be adjusted to have approximately 20 mm of slack per meter of distance between the center of the driver and driven shaft (0.25 inches of slack per foot of distance between the center of the driver and driven shaft) or approximately 2% of the distance between the center of the driver and the driven shaft.
- Vertical drive chains that see shock loads or changes of rotation must be adjusted to have approximately 10 mm of slack per meter of distance between the center of the driver and the center of the driven shaft (0.125 inches of slack per foot of distance between the center of both the driver and the driven shaft) or approximately 1% of the distance between the center of the driver and the center of the driven shaft.

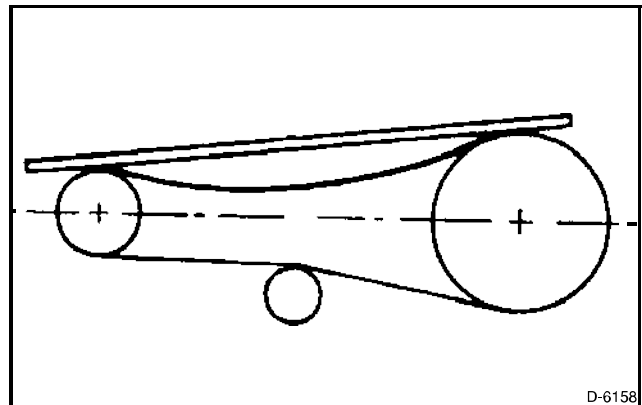

FIG. 14

Drive Chain Sprocket and Idler Alignment

FIG. 15: If there is wear on the inside surface of the chain roller link plates, the sprockets are not aligned. Make sure that:

The shafts (that the driver and driven sprockets are mounted on) are in the same location (level with each other).

Check for tilting or shafts not in alignment by using a bubble level. For proper alignment, the bubble must be in the same position as measured on each shaft.

Rotate the drive and look for excessive movement. If movement is shown inspect the sprocket and shaft. If there is no problem shown, remove and install sprocket. Not correctly mounted sprockets or out of round sprockets are from time to time the root of vibration or more severe problems. A dial indicator can be used to measure the side to side sprocket movement or diameter vibration by holding the dial indicator up to the sprocket sidewall.

IMPORTANT: Always turn off the machine before using the dial indicator. Rotate the drive by hand to make the measurements.

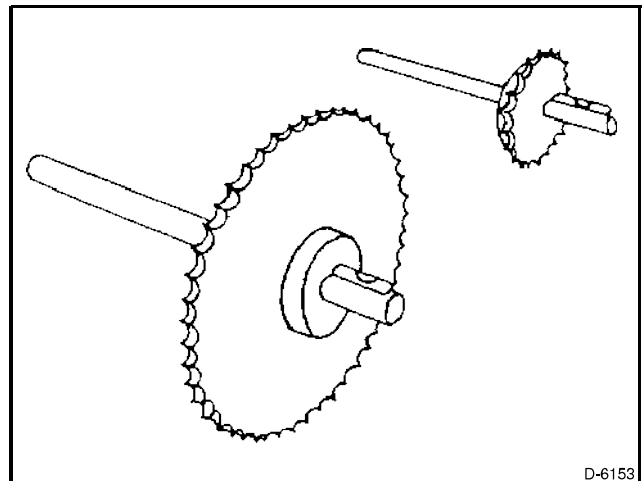

FIG. 15

General Information

FIG. 16: The shafts (that the driver and driven sprockets are mounted on) are parallel to each other.

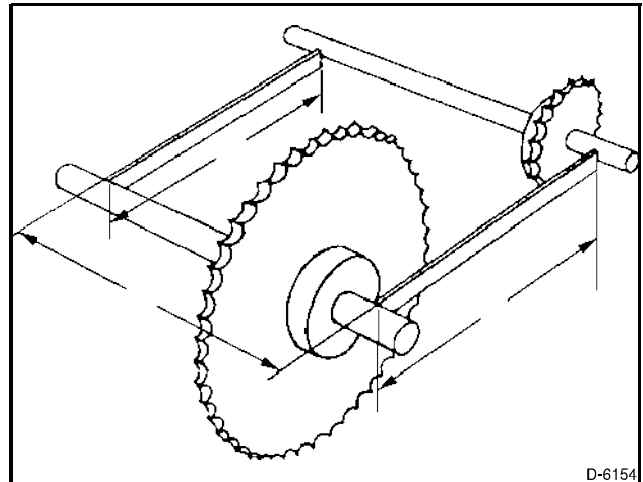

FIG. 16

FIG. 17: The driver and driven sprockets are in line (not offset).

To check the alignment use a long straight edge (1) made of wood, metal, or any rigid material. Line the straight edge along the outside face of both sprockets. If the drive is properly aligned, the straight edge will contact each sprocket evenly. The straight edge must touch the two outer edges of each sprocket for a total of four points of contact.

Shafts not aligned will show up as a gap between the outside face of the sprocket and the straight edge.

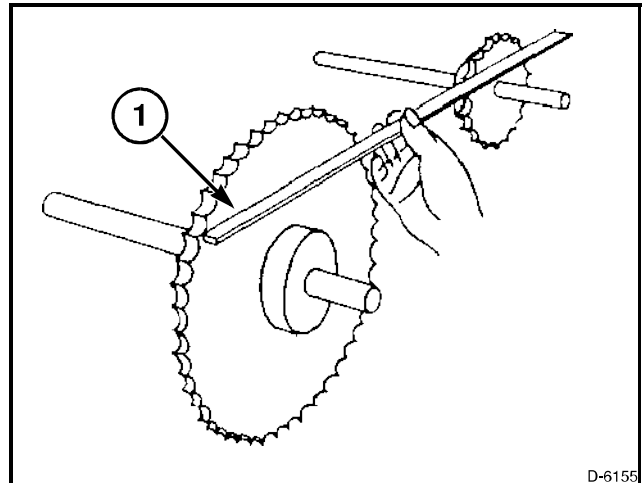

FIG. 17

FIG. 18: The idler and adjusting sprockets are in alignment with the driver and driven sprockets.

Bad alignment, especially with multiple strand chains results in not equal loading across the width of the chain and can cause an early chain failure.

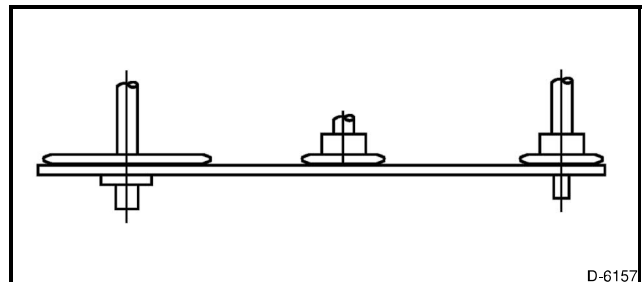

FIG. 18

<https://www.ebooklibonline.com>

Hello dear friend!

Thank you very much for reading.

Enter the link into your browser.

The full manual is available for immediate download.

<https://www.ebooklibonline.com>