

**1745**  
**Round Baler**  
**Workshop Service Manual**

---

**MASSEY FERGUSON®**

**1745**

**Round Baler**

**4283399M1**

**CONTENTS**

GENERAL INFORMATION .....	01
DRIVES.....	02
PICKUP.....	03
ELECTRICAL .....	04
BALE FORMING .....	05
BALE WRAPPING.....	06
CHASSIS .....	07
HYDRAULICS .....	08
INDEX .....	09

---

**NOTES**

**<https://www.ebooklibonline.com>**

Hello dear friend!

Thank you very much for reading.

Enter the link into your browser.

The full manual is available for immediate download.

**<https://www.ebooklibonline.com>**

**Massey Ferguson®**

**1745  
Round Baler**

**WORKSHOP SERVICE MANUAL  
4283399M1**

**01 - General Information**

**Contents**

Safety .....	01-3
Safety Alert Symbol .....	01-3
Safety Signs .....	01-3
Safety Messages .....	01-3
Informational Messages .....	01-3
Manual .....	01-4
A Word to the Operator .....	01-4
Prepare for Operation .....	01-5
Operation .....	01-5
Travel On Public Roads .....	01-7
Fire Prevention .....	01-8
Maintenance .....	01-8
Tire Safety .....	01-10
Introduction .....	01-11
Units of Measurement .....	01-11
Replacement Parts .....	01-11
Serial Number Plate Location .....	01-11
Machine Identification .....	01-11
Baler Operation .....	01-12
Tailgate Lockout Valve .....	01-13
Baler Components .....	01-14
Specifications .....	01-19
Dimensions and Weights .....	01-19
Bale Size .....	01-19
Bale Chamber .....	01-19
Tires .....	01-20
Drives .....	01-20
Pickup .....	01-20
Twine Wrapping Mechanism .....	01-20
Lighting .....	01-20
Tractor Requirements .....	01-21
Lubrication .....	01-21
General Service Procedures .....	01-22
Bolt Torque Values .....	01-22
Wheel Hardware .....	01-22
Bearing Replacement (Eccentric Self-Locking Collar) .....	01-23
Gib Key Removal And Installation .....	01-24

**NOTES**

## GENERAL INFORMATION

### SAFETY

#### Safety Alert Symbol

**FIG. 1:** The safety alert symbol means ATTENTION! BECOME ALERT! YOUR SAFETY IS INVOLVED!

This safety alert symbol indicates important safety messages in this Operator Manual. When you see this symbol, carefully read the message that follows and be alert to the possibility of personal injury or death.

#### Safety Signs

If a used machine has been purchased, be sure all safety signs are in the correct location and can be read.

Replace any safety signs that can not be read or are missing. Replacement safety signs are available from your dealer. The location of safety signs is illustrated at the end of this division.



FIG. 1

#### Safety Messages

**FIG. 2:** Whenever you see the words and symbols shown below, used in this manual, you MUST take note of their instructions as they relate to personal safety.

 **DANGER:** Indicates an imminently hazardous situation that, if not avoided, will cause death or very serious injury.

 **WARNING:** Indicates a potentially hazardous situation that, if not avoided, could result in death or serious injury.

 **CAUTION:** Indicates a potentially hazardous situation that, if not avoided, may result in minor injury.



FIG. 2

#### Informational Messages

The words IMPORTANT and NOTE are not related to personal safety, but are used to give additional information and tips for operating or servicing this equipment.

*IMPORTANT: Identifies special instructions or procedures which, if not strictly observed, could result in damage to or destruction of the machine, process, or its surroundings.*

*NOTE: Identifies points of particular interest for more efficient and convenient repair or operation.*

## General Information

---

### Manual

The photos, illustrations, and data used in this manual were current at the time of printing, but due to possible in-line production changes, your machine can vary slightly in detail. The manufacturer reserves the right to redesign and change the machine as necessary without notification.



**WARNING:** In some of the illustrations or photos used in this manual, panels or guards may have been removed for clarity. Never operate the machine with any panels or guards removed. If the removal of panels or guards is necessary to make a repair, they **MUST** be replaced before operation.

### A Word to the Operator

**FIG. 3:** It is YOUR responsibility to read and understand the Safety section in this book before operating this machine. Remember that YOU are the key to safety. Good safety practices not only protect you, but also the people around you. Study the features in this book and make them a working part of your safety program. Keep in mind that this Safety section is written only for this type of machine. Practice all other usual and customary safe working precautions, and above all **REMEMBER - SAFETY IS YOUR RESPONSIBILITY. YOU CAN PREVENT SERIOUS INJURY OR DEATH.**

This Safety section is intended to point out some of the basic safety situations that may be encountered during the normal operation and maintenance of your machine, and to suggest possible ways of dealing with these situations. This section is **NOT** a replacement for other safety practices featured in other sections of this book.

**IMPORTANT:** *This manual covers general safety practices for this machine. It must always be kept with the machine.*



**WARNING:** An operator should not use alcohol or drugs which can affect their alertness or coordination. An operator on prescription or 'over the counter' drugs needs medical advice on whether or not they can properly operate machines.

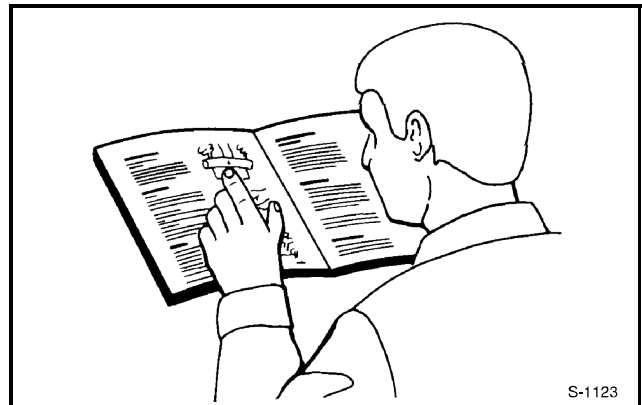

**FIG. 3**

S-1123

### Prepare for Operation

Read this manual completely and make sure you understand the controls. Know the positions and operations of all controls before you operate this machine. Check all controls in an area clear of people and obstacles before starting your work.

All equipment has a limit. Make sure you understand the speed, brakes, steering, stability, and load characteristics of this machine before you start.

Make sure your machine has the correct equipment needed by the local regulations.

### Operation

Make sure the machine is in the proper operating condition as stated in the Operator Manual.

Make sure the tractor is in proper operating condition with the brakes adjusted, especially when operating on terrain that is not even.

To achieve proper braking capacity, the weight of the baler with a bale must not exceed 1.5 times the weight of the tractor.

**FIG. 4:** Wear all protective clothing and personal protective equipment issued to you or called for by job conditions. Wear approved hearing protection whenever operating the machine as required by country/local regulations. Do not wear loose clothing, jewelry, or other items that could entangle in moving parts. Tie up long hair that also could entangle in moving parts. Always keep hands, feet, hair, and clothing away from moving parts.

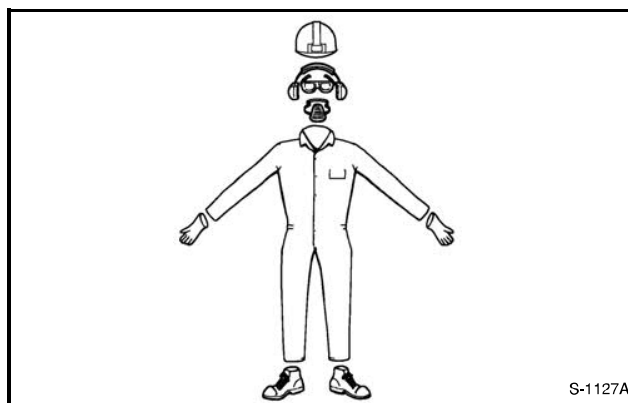

**FIG. 4**

**FIG. 5:** Securely fasten your seat belt before operating the machine. Always remain seated when operating the machine.

Never start the tractor with PTO engaged.

Always slide the hitch pin lock plate over the hitch pin and install the Klik pin when connecting the baler to the tractor.

Always install the safety transport chain between the baler and tractor drawbar.

- Use a chain with a strength rating equal to or more than the gross weight of the towed machine.
- Supply only enough slack in the chain to permit turning.
- Do not use the safety transport chain as a tow chain for towing.

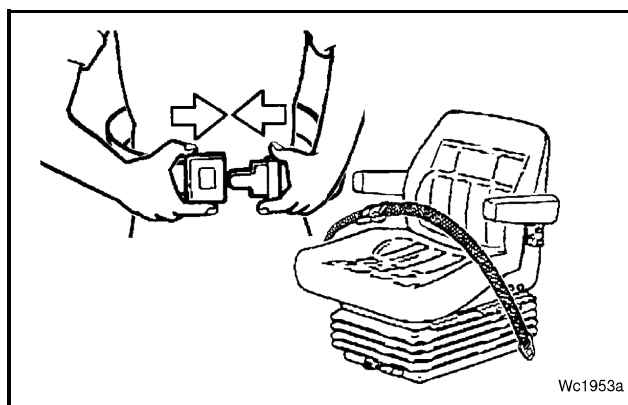

**FIG. 5**

## General Information

**FIG. 6:** Always put the tractor transmission in park and apply the parking brake and remove the tractor key when parking the machine and take the key with you.

Do not allow children or unqualified persons to operate your machine.

Do not permit others to ride on the machine. Keep others away from your area of work.

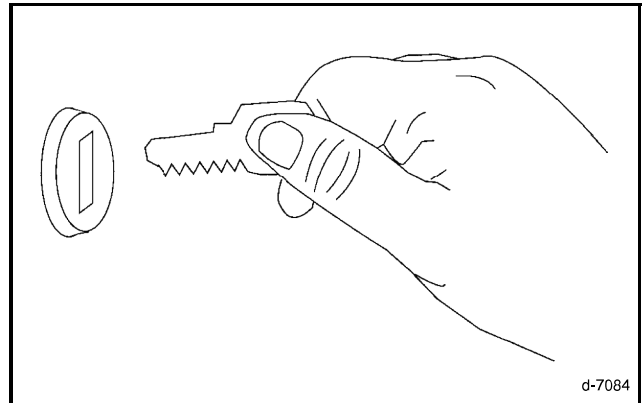

**FIG. 6**

**FIG. 7:** Because of the flammable nature of many hay crops, a water fire extinguisher must be placed within easy reach.

Keep a first aid kit handy for treatment for minor cuts and scratches.

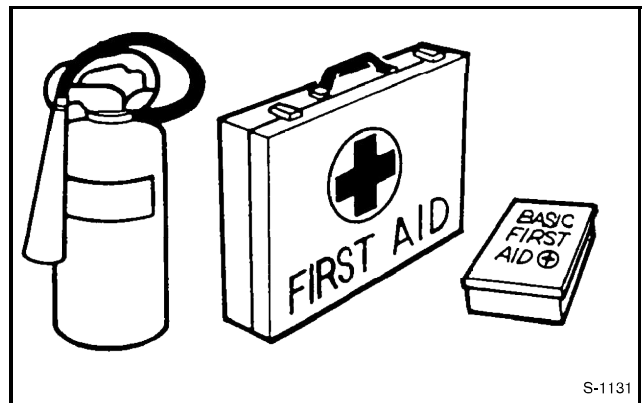

**FIG. 7**

**FIG. 8:** Stay at least 3.7 m (12 ft) away from the tailgate at all times. The tailgate operates faster than you can move away.

Always make sure the area around the tailgate is clear for at least 3.7 m (12 ft) before opening the tailgate and unloading the bale. Keep bystanders away from the baler and the tailgate when unloading a bale.

Before raising the tailgate, make sure the baler is securely fastened to the tractor drawbar. The baler tongue may lift up when the tailgate is raised. This can cause the baler to tip to the rear, causing personal injury or damage to the machine.

Avoid contact with electrical power lines. Never open the tailgate near electrical wires. Contact with electrical power lines can cause electrical shock, resulting in very serious injury or death.

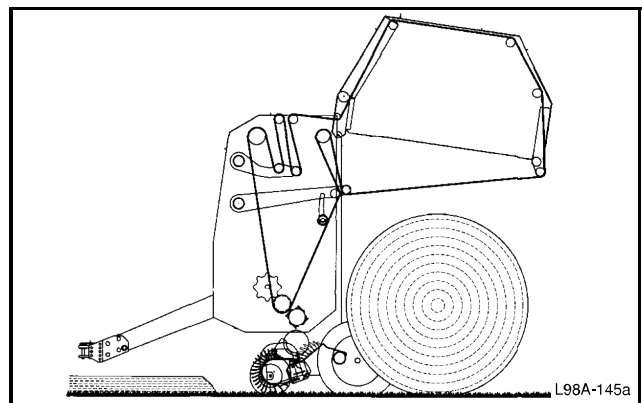

**FIG. 8**

## General Information

**FIG. 9:** When moving bales, never use a tractor front end loader that is not equipped with a grapple or the proper bale handling equipment. Use the grapple to prevent the bale from rolling down the loader frame onto the operator. Always keep the load close to the ground to keep from off-balancing the tractor.

Never unload or store bales on a slope where bales can roll.

Always disengage the tractor PTO, put the tractor transmission in PARK and apply the parking brake before getting off of the tractor. Stop the tractor engine and remove the key before servicing or doing any maintenance on the machine.

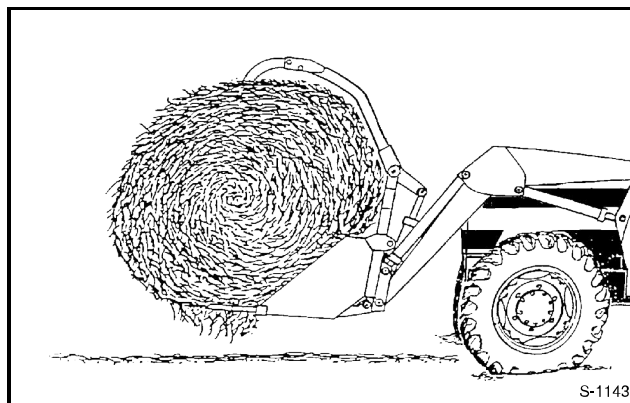

**FIG. 9**

### Travel On Public Roads

**FIG. 10:** Use the lighting and marking system supplied with the machine when roading.

Make sure reflectors are correctly installed, in good condition, and wiped clean. Be sure the SMV emblem is clean, visible, and correctly mounted on the rear of the machine.

Familiarize yourself with and obey all road regulations that apply to your machine. Consult your local law enforcement agency for local regulations regarding movement of farm equipment on public roads.

Adjust travel speed to maintain control at all times. Limit speeds to 32 km/hr (20 mi/hr).

Be aware of other traffic on the road. Keep well over to your own side of the road and pull over, whenever possible, to let faster traffic pass.

Be aware of the overall width and length of the machine. Be careful when transporting the machine on narrow roads and across narrow bridges.

Do not road the baler with a bale in the chamber.

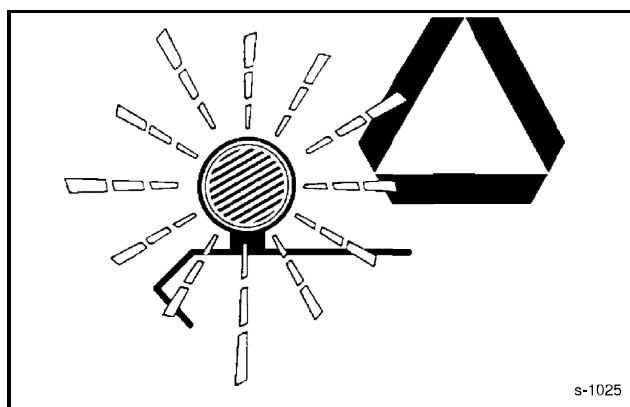

**FIG. 10**

## General Information

### Fire Prevention

**FIG. 11:** Due to the nature of the crops this machine will operate in, the risk of fire is of concern. Regular inspection of the machine can reduce the risk of fire. Keep the machine free of crop debris.

Check the machine daily for any noises that are not normal. Such noises could indicate a failed bearing that can cause heat buildup.

When finished baling and before leaving baler, remove the bale from the bale chamber. Raise the tailgate and put the tailgate lockout valve in the lock position. Check for accumulation of hay or hot spots in the bale chamber and pickup area. Remove hay accumulation. Put the tailgate lockout valve in the unlock position and lower the tailgate.

If a fire occurs while baling, eject the bale, move tractor and baler upwind away from bale 12 m (40 ft). Raise the tailgate. Engage the tailgate lockout valve in the LOCKED position. Use a fire extinguisher or other water source to put out the fire.

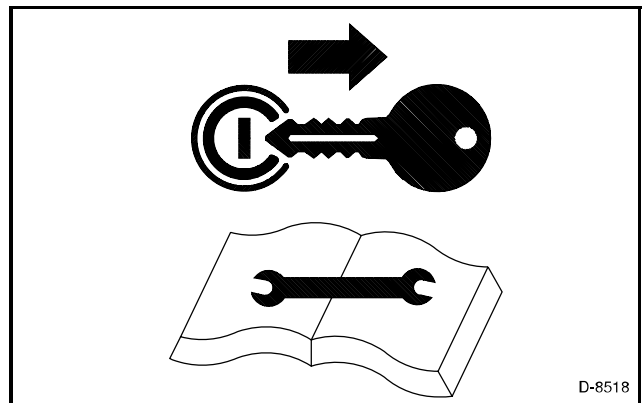

**FIG. 11**

### Maintenance

**FIG. 12:** Before doing any unplugging, lubricating, servicing, cleaning, or adjusting:

- Park the machine on a solid level surface.
- Close the tailgate.
- Disengage the tractor PTO.
- Put the tractor transmission in PARK and apply the tractor parking brake.
- Stop the tractor engine and take the key with you.
- Put the tailgate lockout valve into the LOCKED position if the tailgate is raised.
- Look and Listen! Make sure all moving parts have stopped.
- Put blocks in front of and behind the wheels of the tractor and the baler before working on or under the baler.



**FIG. 12**

**FIG. 13:** Never service, check or adjust drive chains or belts while the tractor engine is running.

Never remove crop, twine, or mesh from the machine while the tractor engine is running. Moving parts can pull you in faster than you can move away.



**FIG. 13**

## General Information

**FIG. 14:** DO NOT operate the machine with drive shafts shields open or removed. Entanglement in rotating drive shafts can cause serious injury or death.

Stay clear of rotating components.

Make sure rotating guards turn freely.

A loose yoke can slip off the tractor PTO shaft and result in injury to persons or damage to the machine.

When installing a quick disconnect yoke, the spring activated locking pins must slide freely and be seated in the groove on the PTO shaft.

Pull on the implement driveline to make sure the quick disconnect yoke cannot be pulled off the PTO shaft.



**FIG. 14**

**FIG. 15:** When the tailgate is raised for any maintenance or service work, put the tailgate lockout valve (1) into the LOCKED position.

Always unload the bale from the bale chamber before raising or working under the machine.

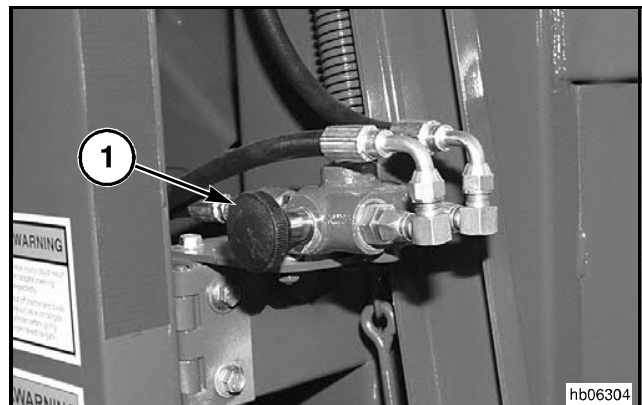

**FIG. 15**

**FIG. 16:** Escaping hydraulic fluid under high pressure can be almost invisible but can penetrate the skin causing serious injury.

Fluid injected into the skin must be surgically removed within a few hours. If not treated immediately, serious infection or reaction can develop. See a doctor familiar with this type of injury immediately.

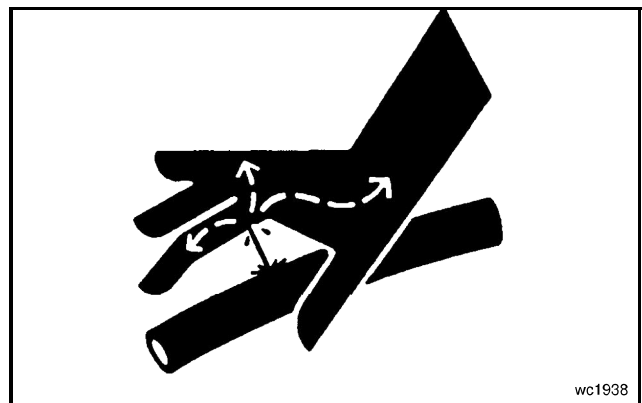

**FIG. 16**

**FIG. 17:** Use a piece of cardboard or wood to search for possible leaks, never use your hands. Wear leather gloves for hand protection and safety goggles for eye protection. DO NOT use your bare hand.

Relieve all pressure before disconnecting any hydraulic lines. Make sure all connections are tight and hydraulic lines are not damaged before applying pressure.

Make sure electrical connectors are free of dirt and grease before connecting.

Check for loose, broken, missing, or damaged parts. Have everything in good repair. Make sure all guards and shields are in place.

Check all nuts and bolts periodically for tightness.

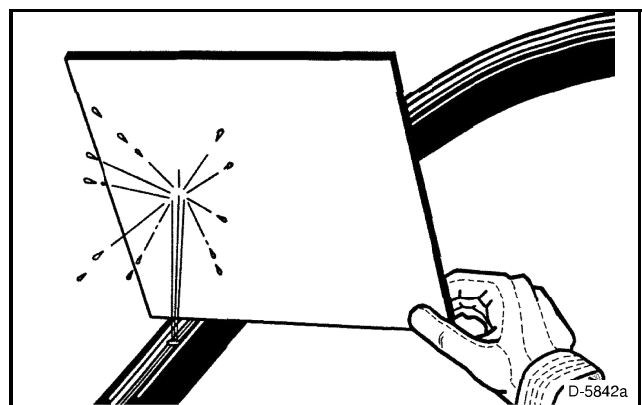

**FIG. 17**

## General Information

---

After unplugging, lubricating, servicing, cleaning, or adjusting the machine make sure all tools and equipment have been removed.

### Tire Safety

**FIG. 18:** Tire explosion and/or serious injury can result from over inflation. Do not exceed tire inflation pressures. See Tires in Specifications for correct tire pressure.

Check tires for cuts and bulges. Replace worn or damaged tires. When tire service is necessary, have a qualified tire mechanic service the tire. See Tires in Specifications for correct tire size.

Do not weld on the rim when a tire is installed. Welding will cause an explosive air/gas mixture that will ignite with high temperatures. This can happen to tires that are inflated or deflated. Removing air or breaking the bead is NOT enough.



**FIG. 18**

## INTRODUCTION

The operation and maintenance instructions included in this manual are assembled from field testing and other data. The information is written for general conditions. Make adjustments as necessary for specific conditions.

Right-hand and left-hand, as used in this manual, is determined by facing the direction the machine will travel when in use.

## Units of Measurement

Measurements are given in metric units of measurement followed by the equivalent in U.S. units. Hardware sizes are given in millimeters for metric hardware and inches for U.S. hardware.

## Replacement Parts

To receive prompt efficient service, always remember to give the dealer the following information:

- Correct part description or part number.
- Model number of your machine.
- Serial number of your machine.

## Serial Number Plate Location

**FIG. 19:** The serial number plate (1) is located on the inside of the left-hand side panel.

## Machine Identification

Machine Model No.: \_\_\_\_\_

Machine Serial No.: \_\_\_\_\_

Date of Delivery: \_\_\_\_\_

Dealer Name and Address: \_\_\_\_\_

\_\_\_\_\_

\_\_\_\_\_

Dealer's Telephone No.: \_\_\_\_\_

Dealer's Fax No.: \_\_\_\_\_

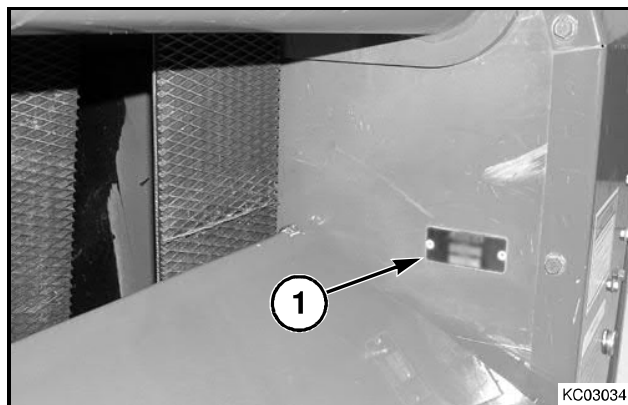

**FIG. 19**

## General Information

### Baler Operation

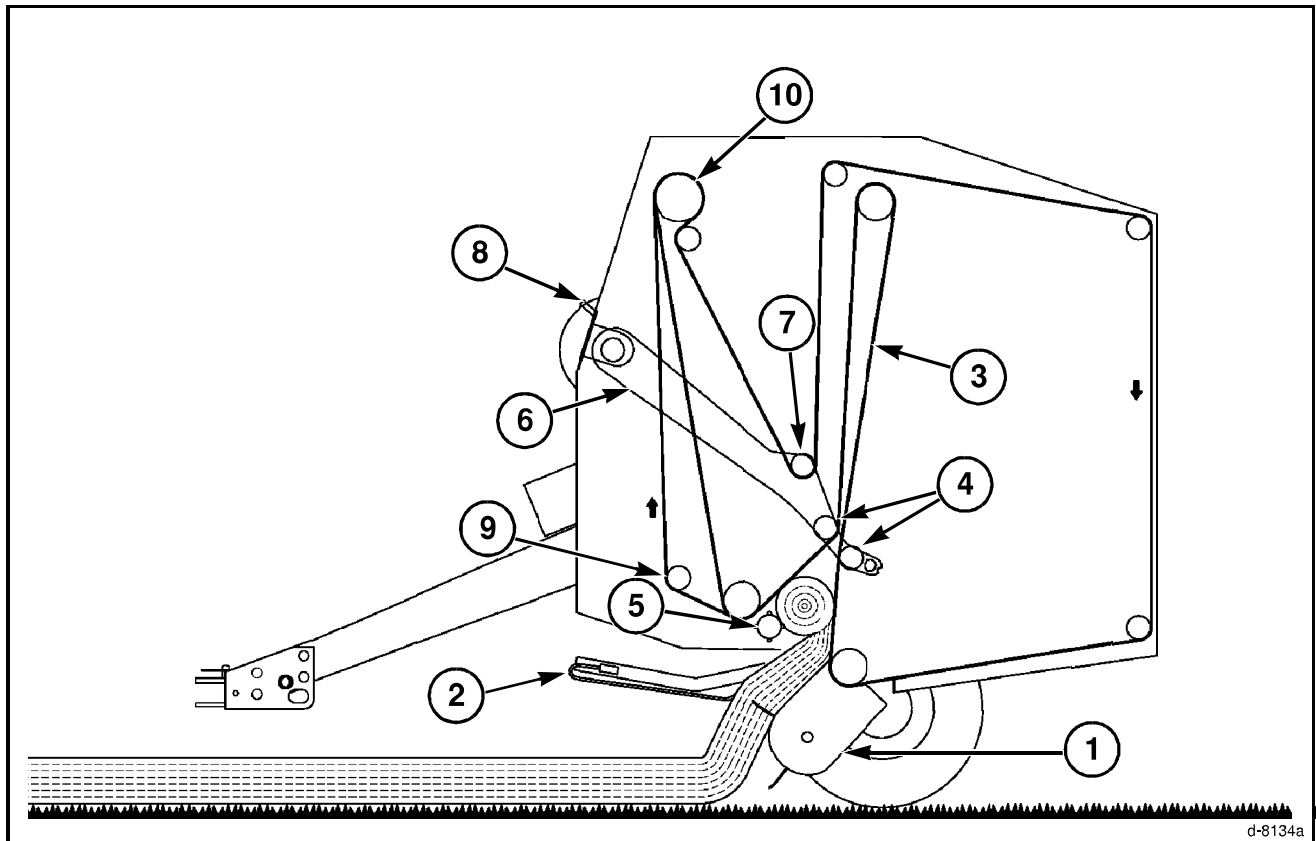

d-8134a

FIG. 20

**FIG. 20:** The illustration shows the windrowed crop being picked up. The crop moves across the pickup assembly (1) into the bottom of the open throat bale chamber. The windguard (2) holds the crop against the pickup assembly. In the bale chamber the crop contacts the rough top surface of the forming belts (3), which are moving upward. The forming belts carry the crop to the top of the starting chamber which is formed by the bale density rolls (4). The downward motion of the forming belts turns the crop downward against the starting roll (5). The starting roll folds the crop rearward into the crop coming in. The core is started and begins to roll.

Springs and hydraulic cylinders pull down on the tension arm (6). The bale density rolls are held down to reduce the size of the bale chamber to a starting size. The belt tension roll (7) is held down to remove the slack from the forming belts. As the bale increases in size, the bale density rolls are forced upward moving the bale size indicator (8) downward. The bale density roll puts an increasing downward force against the bale. This force keeps tension on the bale and compresses the crop coming into the baler.

The stagger roll (9) holds the outside forming belts in front of the other forming belts. This releases crop deposits from behind the forming belts.

The forming belts are driven by the drive roll (10).

**FIG. 21:** The illustration shows the full size bale. The bale density rolls (1) have moved upward, to increase the size of the bale chamber. The bale is on the tailgate carrier roll (2).

The bale must now be wrapped with twine and unloaded.

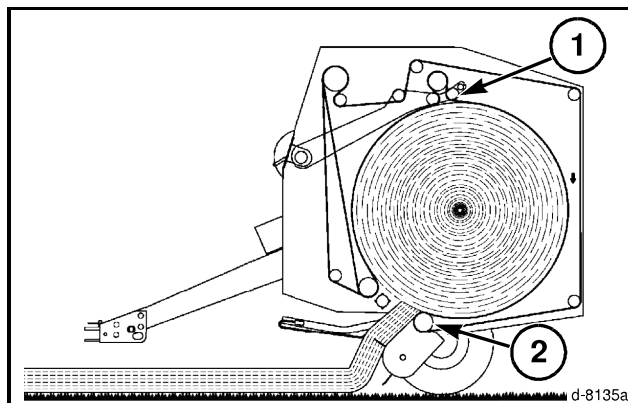

**FIG. 21**

### Tailgate Lockout Valve

**FIG. 22:** When the tailgate is raised for any maintenance or service work, push the lockout valve (1) into the LOCKED position to prevent the tailgate from being lowered. The tailgate can only be lowered when the tailgate lockout valve is released (pulled out).

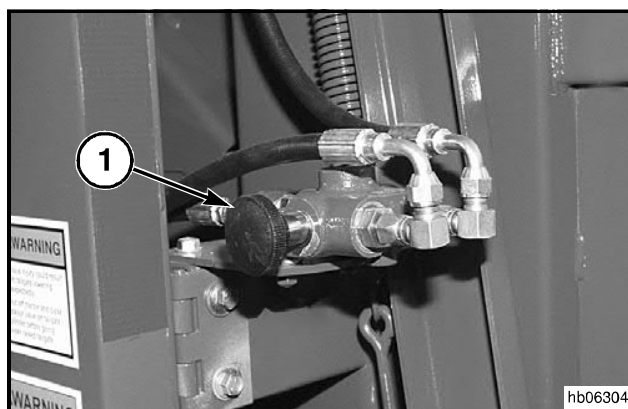

**FIG. 22**

## General Information

### Baler Components

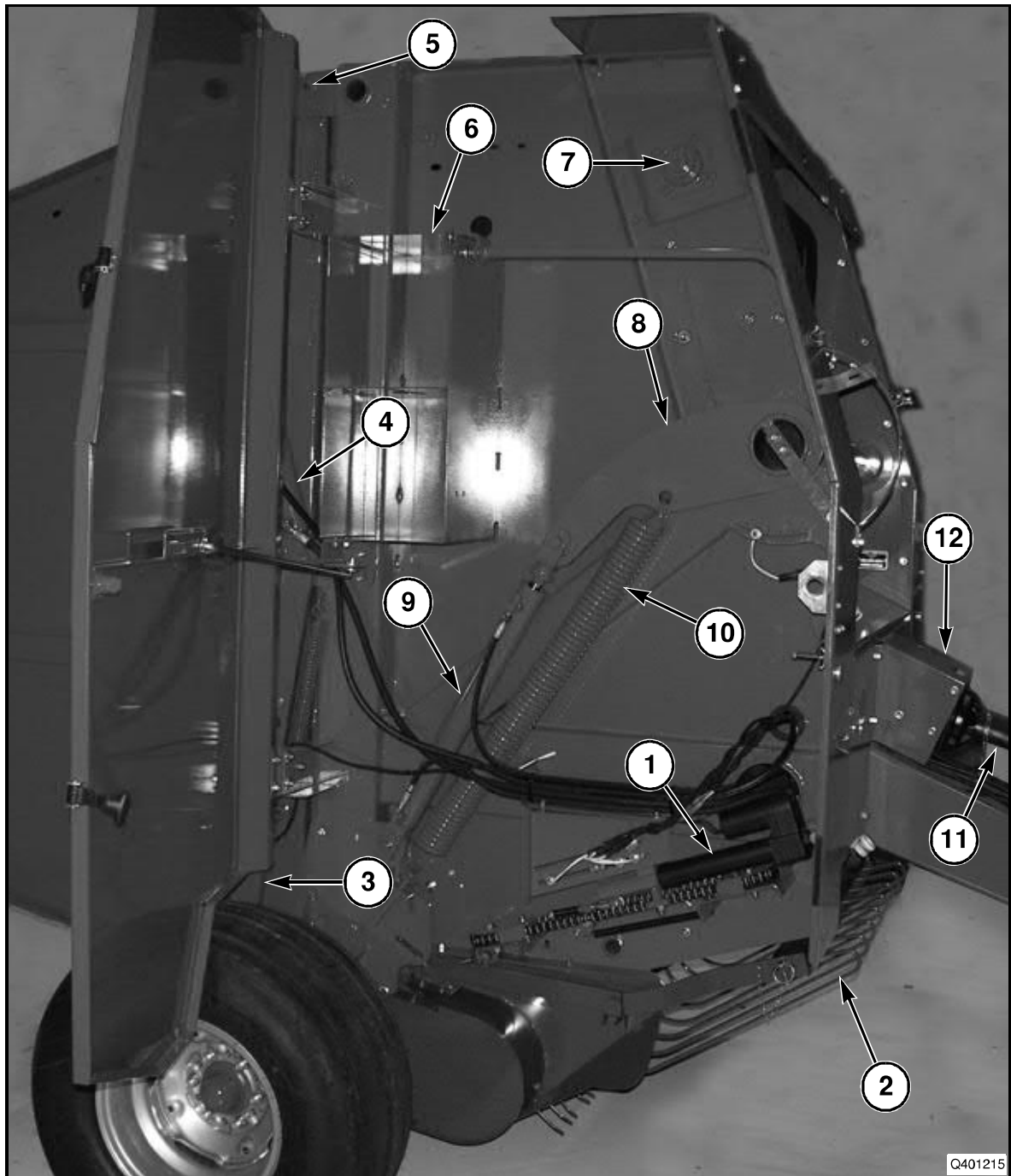

**FIG. 23**

**FIG. 23:** Right-hand side of the baler.

- |                                 |                                       |
|---------------------------------|---------------------------------------|
| (1) Twine arm actuator          | (7) Drive roll shaft                  |
| (2) Windguard                   | (8) Forming belts tensioning arm      |
| (3) Tailgate latch strap        | (9) Forming belts tensioning cylinder |
| (4) Tailgate hydraulic cylinder | (10) Forming belts tensioning spring  |
| (5) Tailgate hinge pivot point  | (11) Implement driveline              |
| (6) Right-hand twine box        | (12) Slip clutch                      |



**Suggest:**

**For more complete manuals. Please go to the home page.**

**<https://www.ebooklibonline.com>**

**If the above button click is invalid. Please download this document first, and then click the above link to download the complete manual.**

**Thank you so much for reading**

### Tailgate

The tailgate is the rear half section of the bale chamber and is supported by a hinge at the top. The tailgate is operated by two hydraulic cylinders to unload the bale. The tailgate has two forming belt idler rolls and a bale carrier roll.

When the tailgate closes, the hydraulic cylinder must be completely retracted in to latch the tailgate. If the tailgate is not latched, the tailgate will swing open as the core is started and the core will stop rolling. The bale must be unloaded. The tailgate hydraulic cylinders are connected to linkage that releases the latches when the tailgate is opened.

### Pickup Assembly

**FIG. 24:** The pickup assembly (1) picks up and feeds the hay into the bale chamber. The major components of the pickup assembly are the rotor shaft, tine bars, cam track, windguard, and the pickup height control crank.

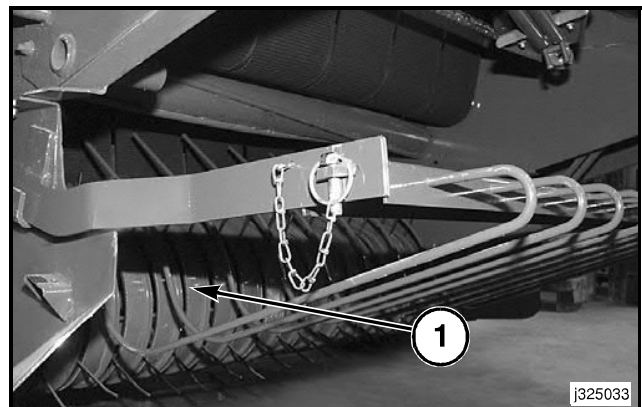

FIG. 24

### Forming Belts

**FIG. 25:** The forming belts are made of a high tensile strength, controlled stretch, synthetic fabric bonded to the covering material. The surface pattern on the forming belts helps to roll the bale. See Specifications for more information on the forming belts.

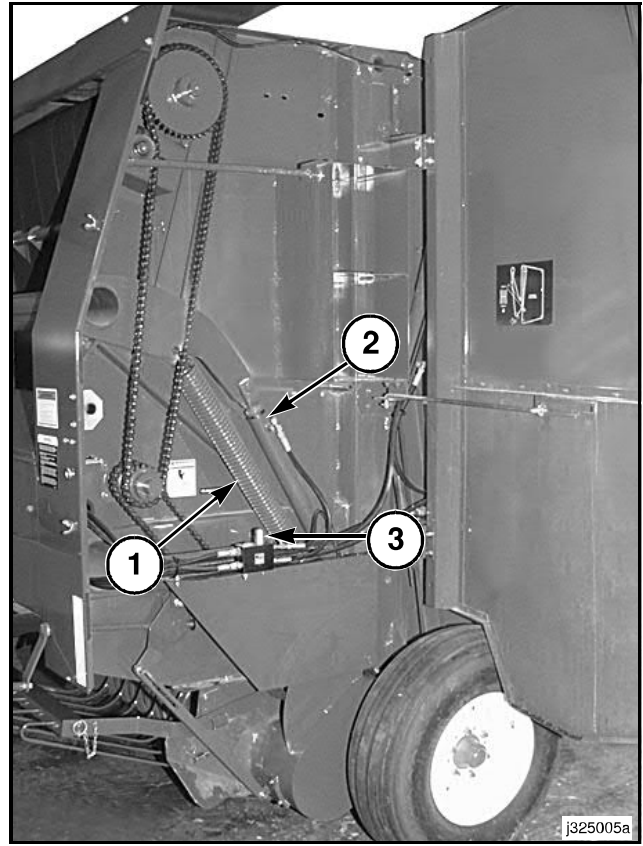

FIG. 25

## General Information

### Bale Density System

**FIG. 26:** The bale density is controlled by two springs (1) and a hydraulic tension system. As the bale increases in size, oil is forced from the rod end of the forming belts tensioning cylinder (2) through a non-adjustable relief valve (3) to the base end. The pressure in the hydraulic tension system is held at 13 790 kPa (2000 psi).

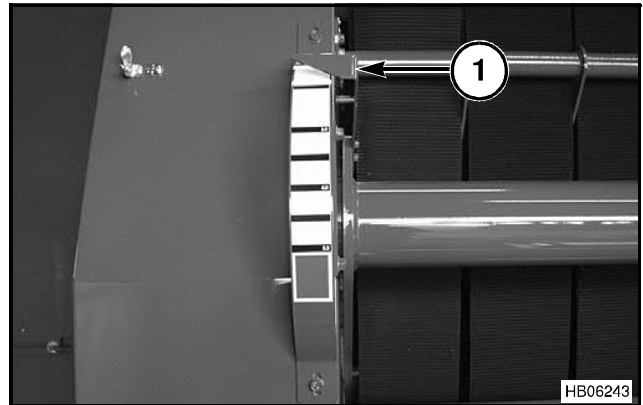

**FIG. 26**

### Bale Size Indication

**FIG. 27:** The bale size indicator (1) is located on the front right-hand side of the baler. As the bale increases in size, the bale size indicator pointer will move down. Begin wrapping the bale immediately when the bale has reached the desired size.

The bale size indicator must be checked for accuracy for each tractor used.



**FIG. 27**

**<https://www.ebooklibonline.com>**

Hello dear friend!

Thank you very much for reading.

Enter the link into your browser.

The full manual is available for immediate download.

**<https://www.ebooklibonline.com>**