

Workshop Service Manual

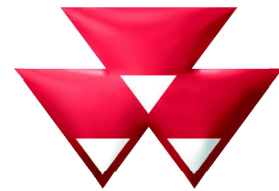

MASSEY FERGUSON

Rotary Disc Mower

1373

1376

North America
4205 River Green Parkway, Duluth GA 30096 USA
© AGCO 2018

August 2018
4283621M1
NA
English

Rotary Disc Mower

1	General	1-1
1.1	General information	1-3
1.1.1	Introduction to this service manual	1-3
1.1.2	Units of measurement	1-3
1.1.3	Conversion table	1-4
1.1.4	Table of contents	1-5
1.1.5	Page numbers	1-5
1.1.6	Intended use	1-5
1.1.7	Proper disposal of waste	1-5
1.1.8	Weld on the machine precautions	1-5
1.2	Safety	1-6
1.2.1	Introduction	1-6
1.2.1.1	Safety symbol	1-6
1.2.1.2	Safety messages	1-6
1.2.1.3	Information messages	1-6
1.2.1.4	Safety signs	1-6
1.2.1.5	A word to the technician	1-7
1.2.1.6	The service manual	1-8
1.2.2	Operation	1-8
1.2.2.1	Prepare for operation	1-8
1.2.2.2	General information	1-8
1.2.2.3	Personal protective equipment	1-9
1.2.2.4	Seat instructions	1-10
1.2.2.5	Shield and guards	1-10
1.2.2.6	Power take-off safety	1-11
1.2.2.7	Exhaust warning	1-11
1.2.2.8	Flying debris	1-12
1.2.2.9	Agricultural chemicals	1-12
1.2.2.10	Travel on public roads	1-12
1.2.3	Maintenance	1-13
1.2.3.1	General maintenance information	1-13
1.2.3.2	Fire prevention and first aid	1-15
1.2.3.3	High pressure leaks	1-16
1.2.3.4	Accumulator safety	1-17
1.2.3.5	Tire safety	1-17
1.2.3.6	Replacement parts	1-18
1.3	Cylinder stops	1-19
1.3.1	Lift cylinder lockout valves	1-19
1.3.1.1	Engage the lift cylinder lockout valves	1-19
1.3.1.2	Disengage the lift cylinder lockout valves	1-20
1.3.2	Steering cylinder lockout valves	1-20
1.3.2.1	Engage the steering cylinder lockout valves	1-21
1.3.2.2	Disengage the steering cylinder lockout valves	1-21
1.4	Machine identification	1-22
1.4.1	Serial number plate	1-22
1.4.2	Tongue serial number	1-22
1.4.3	Serial number description	1-23
1.5	Specifications	1-24
1.5.1	Dimensions and weights	1-24
1.5.2	Header specifications	1-24
1.5.3	Cutterbed specifications	1-24

1.5.3.1	Cutterbed bolt torque	1-24
1.5.4	Drive system specifications	1-25
1.5.5	Tire specifications	1-25
1.5.6	Tractor specifications	1-25
1.5.7	Maximum roading speed	1-25
1.5.8	Conditioner specifications	1-26
1.5.9	Lubrication specifications	1-26
1.6	Description of a pull type rotary mower conditioner	1-28
1.6.1	Cutterbed	1-28
1.6.2	Conditioner	1-28
1.6.3	Swathboard	1-28
1.6.4	Forming shields	1-28
1.6.5	Component access	1-29
1.6.6	Component location	1-30
1.7	Bearing replacement	1-34
1.7.1	Remove a lock collar	1-34
1.7.2	Install a lock collar	1-34
2	Drive system	2-1
2.1	Implement driveline	2-3
2.1.1	Remove the implement driveline	2-3
2.1.2	Install the implement driveline	2-4
2.2	Tongue driveline	2-5
2.2.1	Tongue driveline components	2-5
2.2.2	Remove the tongue driveline	2-5
2.2.3	Examine the tongue driveline	2-6
2.2.4	Install the tongue driveline	2-7
2.3	Clutch driveline	2-9
2.3.1	Remove the clutch driveline	2-9
2.3.2	Install the clutch driveline	2-9
2.4	Slip clutch	2-12
2.4.1	Slip clutch components	2-12
2.4.2	Run in the slip clutch	2-12
2.4.3	Remove the slip clutch	2-13
2.4.4	Disassemble the slip clutch	2-13
2.4.5	Examine the slip clutch	2-15
2.4.6	Assemble the slip clutch	2-16
2.5	Overrunning clutch	2-18
2.5.1	Remove the overrunning clutch	2-18
2.5.2	Disassemble the overrunning clutch	2-19
2.5.3	Examine the overrunning clutch	2-20
2.5.4	Assemble the overrunning clutch	2-21
2.5.5	Install the overrunning clutch	2-22
2.6	Cutterbed driveline	2-25
2.6.1	Remove the cutterbed driveline	2-25
2.6.2	Install the cutterbed driveline	2-25
2.7	Conditioner drivelines	2-27
2.7.1	Conditioner driveline components	2-27
2.7.2	Remove the conditioner driveline	2-28
2.7.3	Disassemble the conditioner driveline	2-29
2.7.4	Examine the conditioner drivelines	2-29
2.7.5	Assemble the conditioner roll driveline	2-30
2.7.6	Install the conditioner driveline	2-30
2.8	Universal joint bearing replacement	2-32
2.8.1	Disassemble a universal joint	2-32
2.8.2	Examine an universal joint	2-34

<https://www.ebooklibonline.com>

Hello dear friend!

Thank you very much for reading.

Enter the link into your browser.

The full manual is available for immediate download.

<https://www.ebooklibonline.com>

2.8.3	Assemble an universal joint	2-34
2.9	Quick disconnect	2-37
2.9.1	Disassemble the quick disconnect	2-37
2.9.2	Examine the quick disconnect	2-38
2.9.3	Assemble the quick disconnect	2-38
2.10	Belts	2-40
2.10.1	Belt maintenance	2-40
2.10.2	Belt inspection	2-40
2.10.3	Adjust the conditioner belt	2-40
2.10.4	Replace the conditioner belt	2-40
2.10.5	Adjust the tine conditioner belt	2-42
2.10.6	Replace the tine conditioner belt	2-42
2.10.7	Adjust the header drive belt	2-43
2.10.8	Replace the header drive belt	2-43
2.11	Conditioner gearcase lubrication	2-45
2.11.1	Plug location - conditioner gearcases	2-45
2.11.2	Examine the gearcase oil level	2-45
2.11.3	Change the gearcase oil	2-46
2.12	Hay conditioner gearcase	2-47
2.12.1	Conditioner gearcase components	2-47
2.12.2	Remove the conditioner gearcase	2-48
2.12.3	Disassemble the conditioner gearcase	2-49
2.12.4	Examine the conditioner gearcase	2-50
2.12.5	Assemble the conditioner gearcase	2-52
2.12.6	Install the conditioner gearcase	2-56
2.13	Cutterbed gearbox - side pull	2-58
2.13.1	Plug location - cutterbed gearbox	2-58
2.13.2	Examine the gearbox oil level	2-58
2.13.3	Change the gearbox oil	2-59
2.13.4	Remove the cutterbed gearbox	2-59
2.13.5	Disassemble the cutterbed gearbox	2-61
2.13.6	Assemble the cutterbed gearbox	2-64
2.13.7	Install the cutterbed gearbox	2-72
2.14	Header drive gearbox - center pivot	2-75
2.14.1	Plug location - header drive gearbox	2-75
2.14.2	Examine the gearbox oil level	2-75
2.14.3	Change the gearbox oil	2-75
2.14.4	Header drive gearbox components	2-77
2.14.5	Remove the header drive gearbox	2-78
2.14.6	Disassemble the header drive gearbox	2-81
2.14.7	Assemble the header drive gearbox	2-83
2.14.8	Install the header drive gearbox	2-86
2.15	Cutterbed drive gearbox - center pivot	2-90
2.15.1	Plug location - cutterbed drive gearbox	2-90
2.15.2	Examine the gearbox oil level	2-90
2.15.3	Change the gearbox oil	2-90
2.15.4	Remove the cutterbed gearbox	2-91
2.15.5	Cutterbed drive gearbox components	2-95
2.15.6	Disassemble the cutterbed drive gearbox	2-96
2.15.7	Assemble the cutterbed drive gearbox	2-98
2.15.8	Install the cutterbed gearbox	2-100
2.16	Swivel gearbox - center pivot	2-104
2.16.1	Plug location - swivel gearboxes	2-104
2.16.2	Examine the gearbox oil level	2-104
2.16.3	Change the gearbox oil	2-104
2.16.4	Remove the swivel gearbox	2-105
2.16.5	Install the swivel gearbox	2-105

2.16.6	Swivel gearbox	2-107
2.16.6.1	Swivel gearbox components	2-107
2.16.6.2	Disassemble the swivel gearbox	2-108
2.16.6.3	Assemble the swivel gearbox	2-112
3	Hydraulic system	3-1
3.1	General hydraulic information	3-3
3.2	Steering cylinder	3-4
3.2.1	Remove the steering cylinder	3-4
3.2.2	Install the steering cylinder	3-4
3.3	Lift cylinders	3-6
3.3.1	Lift cylinders	3-6
3.3.2	Remove a lift cylinder	3-6
3.3.3	Install a lift cylinder	3-7
3.4	Header angle cylinder, if equipped	3-8
3.4.1	Remove the header angle cylinder	3-8
3.4.2	Install the header angle cylinder	3-8
3.5	Hydraulic cylinder repair	3-10
3.5.1	Examine the cylinder assembly	3-10
3.5.2	Repair a wire ring type cylinder	3-10
4	Electrical system	4-1
4.1	Basic troubleshooting information	4-3
4.1.1	Basic troubleshooting procedures	4-3
4.1.2	Tools	4-4
4.1.3	Continuity check	4-4
4.1.4	Voltage check	4-5
4.2	Connectors	4-6
4.2.1	Examine a connector	4-6
4.2.2	Terminal numbers	4-6
4.2.3	Dielectric grease	4-7
4.2.4	Pins and sockets	4-7
4.2.5	Replace a Packard connector	4-8
4.2.6	Replace an AMP connector	4-8
4.3	Examine the lighting	4-10
4.3.1	Machine lamp plug wiring diagram - North America	4-11
5	Flotation	5-1
5.1	Header flotation	5-3
5.1.1	Adjust the header flotation	5-3
5.2	Flotation springs	5-4
5.2.1	Remove the flotation springs	5-4
5.2.2	Disassemble the flotation springs	5-5
5.2.3	Assemble the flotation springs	5-6
5.2.4	Install the flotation springs	5-6
6	Cutterbar	6-1
6.1	Lubrication	6-3
6.1.1	Cutterbed oil level	6-3
6.1.2	Change the cutterbed oil	6-3
6.2	Cutterbed inspection	6-5
6.3	Discs	6-6
6.3.1	Disc maintenance	6-6
6.3.2	Replace a disc	6-6
6.3.3	Replace a disc spindle assembly	6-7

6.4	Knives	6-9
6.4.1	Knife wedging under disc	6-9
6.4.2	Knife inspection	6-9
6.4.3	Disc rotation	6-10
6.4.4	Replace a fixed blade knife	6-10
6.4.5	Replace a quick change knife	6-11
6.4.6	Replace a knife quick change spring	6-12
6.4.7	Knife type	6-12
6.4.8	Knife hardware inspection	6-13
7	Conditioner	7-1
7.1	Conditioner adjustments - Roll	7-3
7.1.1	Conditioner	7-3
7.1.2	Conditioner spacing	7-3
7.1.2.1	Adjust the conditioner roll spacing	7-3
7.1.3	Conditioner roll pressure	7-3
7.1.3.1	Adjust the conditioner roll pressure	7-4
7.1.4	Adjust the conditioner roll timing	7-4
7.2	Conditioner adjustment - Tine	7-6
7.2.1	Adjust the tine conditioner	7-6
7.3	Roll conditioner	7-7
7.3.1	Remove the conditioner rolls	7-7
7.3.2	Examine the conditioner rolls	7-10
7.3.3	Install the conditioner rolls	7-10
7.4	Tine conditioner	7-14
7.4.1	Replace the tine conditioner	7-14
8	Chassis	8-1
8.1	Forming shields	8-3
8.1.1	Remove the forming shields	8-3
8.1.2	Install the forming shields	8-4
8.2	Swathboard	8-5
8.2.1	Remove the swathboard	8-5
8.2.2	Examine the swathboard	8-6
8.2.3	Install the swathboard	8-6
8.3	Strut and lift arms	8-10
8.3.1	Remove the struts and the lift arms	8-10
8.3.2	Disassemble the strut	8-13
8.3.3	Assemble the strut	8-14
8.3.4	Install the struts and the lift arms	8-15
8.4	3-point hitch	8-19
8.4.1	Remove the 3-point hitch	8-19
8.4.2	Install the 3-point hitch	8-20
8.5	Drawbar hitch	8-22
8.5.1	Remove the drawbar hitch	8-22
8.5.2	Install the drawbar hitch	8-23
8.6	Tongue	8-25
8.6.1	Remove the tongue	8-25
8.6.2	Examine the tongue	8-27
8.6.3	Install the tongue	8-27
9	Spindles and wheels	9-1
9.1	Install the wheels	9-3
9.2	Lubricate the wheel bearings	9-4

10 Diagrams	10-1
10.1 How to read wiring schematics	10-3
10.1.1 Diagram numbers	10-3
10.1.2 Location grids	10-3
10.2 Diagram symbols and abbreviations	10-5
10.2.1 Harness and connector identification	10-5
10.2.2 Splices	10-5
10.2.3 Device identification numbers	10-5
10.3 Electrical diagrams	10-7
10.3.1 Harness abbreviations	10-7
10.3.2 Wire colors	10-7
10.3.3 Electrical diagram	10-9
10.4 Circuit table	10-11
10.5 Connector table	10-13
11 Index	Index-1

1 General

1.1	General information	1-3
1.1.1	Introduction to this service manual	1-3
1.1.2	Units of measurement	1-3
1.1.3	Conversion table	1-4
1.1.4	Table of contents	1-5
1.1.5	Page numbers	1-5
1.1.6	Intended use	1-5
1.1.7	Proper disposal of waste	1-5
1.1.8	Weld on the machine precautions	1-5
1.2	Safety	1-6
1.2.1	Introduction	1-6
1.2.1.1	Safety symbol	1-6
1.2.1.2	Safety messages	1-6
1.2.1.3	Information messages	1-6
1.2.1.4	Safety signs	1-6
1.2.1.5	A word to the technician	1-7
1.2.1.6	The service manual	1-8
1.2.2	Operation	1-8
1.2.2.1	Prepare for operation	1-8
1.2.2.2	General information	1-8
1.2.2.3	Personal protective equipment	1-9
1.2.2.4	Seat instructions	1-10
1.2.2.5	Shield and guards	1-10
1.2.2.6	Power take-off safety	1-11
1.2.2.7	Exhaust warning	1-11
1.2.2.8	Flying debris	1-12
1.2.2.9	Agricultural chemicals	1-12
1.2.2.10	Travel on public roads	1-12
1.2.3	Maintenance	1-13
1.2.3.1	General maintenance information	1-13
1.2.3.2	Fire prevention and first aid	1-15
1.2.3.3	High pressure leaks	1-16
1.2.3.4	Accumulator safety	1-17
1.2.3.5	Tire safety	1-17
1.2.3.6	Replacement parts	1-18
1.3	Cylinder stops	1-19
1.3.1	Lift cylinder lockout valves	1-19
1.3.1.1	Engage the lift cylinder lockout valves	1-19
1.3.1.2	Disengage the lift cylinder lockout valves	1-20
1.3.2	Steering cylinder lockout valves	1-20
1.3.2.1	Engage the steering cylinder lockout valves	1-21
1.3.2.2	Disengage the steering cylinder lockout valves	1-21
1.4	Machine identification	1-22
1.4.1	Serial number plate	1-22
1.4.2	Tongue serial number	1-22
1.4.3	Serial number description	1-23
1.5	Specifications	1-24
1.5.1	Dimensions and weights	1-24
1.5.2	Header specifications	1-24
1.5.3	Cutterbed specifications	1-24

1.5.3.1	Cutterbed bolt torque	1-24
1.5.4	Drive system specifications	1-25
1.5.5	Tire specifications	1-25
1.5.6	Tractor specifications	1-25
1.5.7	Maximum roading speed	1-25
1.5.8	Conditioner specifications	1-26
1.5.9	Lubrication specifications	1-26
1.6	Description of a pull type rotary mower conditioner	1-28
1.6.1	Cutterbed	1-28
1.6.2	Conditioner	1-28
1.6.3	Swathboard	1-28
1.6.4	Forming shields	1-28
1.6.5	Component access	1-29
1.6.6	Component location	1-30
1.7	Bearing replacement	1-34
1.7.1	Remove a lock collar	1-34
1.7.2	Install a lock collar	1-34

1.1 General information

1.1.1 Introduction to this service manual

This service manual gives information from engineering tests, operating data, and the latest service techniques at the time of publication. Read this service manual carefully before doing any service on the machine.

The photos and illustrations used in this service manual were current at the time of publication. Production changes can cause machines to vary from the photos and the illustrations. The manufacturer reserves the right to redesign and change machines as necessary without notification.



WARNING:

Some pictures in this manual show the machine with shields or guards removed to permit for a better view of the subject of the picture. All shields and guards must be in position before operating the machine.

Machine movement when in normal use determines right-hand and left-hand.

1.1.2 Units of measurement

Measurements are given in metric units followed by the equivalent in US units. Hardware sizes are given in millimeters for metric hardware and inches for US hardware.

1.1.3 Conversion table

	MULTIPLY:	BY:	To Get:	MULTIPLY	BY:	To Get:
LINEAR	inches	x 25.4	= millimeters (mm)	x 0.03937	= inches	
	feet	x 0.3048	= meters (m)	x 3.281	= feet	
	yards	x 0.9144	= meters (m)	x 1.0936	= yards	
	miles	x 1.6093	= kilometers (km)	x 0.6214	= miles	
	inches	x 2.54	= centimeters (cm)	x 0.3937	= inches	
	microinches	x 0.0254	= micrometers (um)	x 39.37	= microinches	
AREA	inches ²	x 645.16	= millimeters ² (mm ²)	x 0.00155	= inches ²	
	inches ²	x 6.4516	= centimeters ² (cm ²)	x 0.155	= inches ²	
	feet ²	x 0.0929	= meters ² (m ²)	x 10.764	= feet ²	
	yards ²	x 0.8361	= meters ² (m ²)	x 1.196	= yards ²	
	acres	x 0.4047	= hectometers ² (hm ²)	x 2.471	= acres	
			= hectares (ha)			
VOLUME	inches ³	x 16387	= millimeters ³ (mm ³)	x 0.000061	= inches ³	
	inches ³	x 16.387	= centimeters ³ (cm ³)	x 0.06102	= inches ³	
	inches ³	x 0.01639	= liters	x 61.024	= inches ³	
	quarts	x 0.94635	= liters	x 1.0567	= quarts	
	gallons	x 3.7854	= liters	x 0.2642	= gallons	
	feet ³	x 28.317	= liters	x 0.03531	= feet ³	
	feet ³	x 0.02832	= meters ³ (m ³)	x 35.315	= feet ³	
	fluid oz.	x 29.57	= milliliters (ml)	x 0.03381	= fluid oz.	
	yards ³	x 0.7646	= meters ³ (m ³)	x 1.3080	= yards ³	
	teaspoons	x 4.929	= milliliters (ml)	x 0.2029	= teaspoons	
	cups	x 0.2366	= liters	x 4.227	= cups	
	bushel	x 35.239	= liters	x 0.02838	= bushels	
	bushel	x 0.03524	= meters ³ (m ³)	x 28.378	= bushels	
	MASS	ounces (av)	x 28.35	= grams (g)	x 0.03527	= ounces (av)
pounds (av)		x 0.4536	= kilograms (kg)	x 2.2046	= pounds (av)	
tons (2000 lbs)		x 907.18	= kilograms (kg)	x 0.001102	= tons (2000 lbs)	
tons (2000 lbs)		x .90718	= metric tons(t)	x 1.1023	= tons(2000 lbs)	
tons (long) (2240 lbs)		x 1016.05	= kilograms (kg)	x .000984	= tons (long) (2240 lbs)	
FORCE	ounces - f (av)	x 0.278	= newtons (N)	x 3.597	= ounces - f (av)	
	pounds - f (av)	x 4.488	= newtons (N)	x 0.2248	= pounds - f (av)	
	kilograms - f	x 9.807	= newtons (N)	x 0.10197	= kilograms - f	
PRESSURE OR STRESS	pounds/sq.in.	x 6.895	= kilopascals (kPa)	x 0.145	= pounds/sq. in.	
	pounds/sq.in.	x 0.0689	= bar	x 14.503	= pounds/sq. in.	
POWER	horsepower	x 0.746	= kilowatts (kW)	x 1.34	= horsepower	
	ft-lbf/min.	x 0.0226	= watts (W)	x 44.25	= ft - lbf/min.	
TORQUE	pound - inches	x 0.11298	= newton-meters (N.m)	x 8.851	= pound-inches	
	pound - feet	x 1.3558	= newton-meters (N.m)	x 0.7376	= pound-feet	
VELOCITY	miles/hour	x 1.6093	= kilometers/hour (km/h)	x 0.6214	= miles/hour	
	feet/sec.	x 0.3048	= meters/sec. (m/s)	x 3.281	= feet/sec.	
	kilometers/hr.	x 0.27778	= meters/sec. (m/s)	x 3.600	= kilometers/hr.	
	miles/hours	x 0.4470	= meters/sec. (m/s)	x 2.237	= miles/hour	
TEMPERATURE						
	<p>MetConv.doc</p>					

Fig. 1

1.1.4 Table of contents

This manual has a table of contents at the front. The table of contents shows the divisions. The individual divisions also have a table of contents.

1.1.5 Page numbers

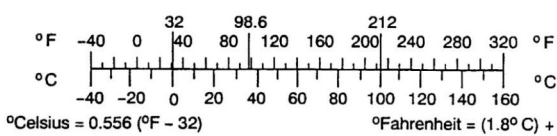
All pages have two numbers, such as 01-25. The first number shows the division. The second number shows the page in the division.

Page numbers occur on the lower right-hand or lower left-hand corner of each page.

1.1.6 Intended use

This machine is designed solely for use in customary agricultural operations.

Do not use this machine for any application or purpose other than those described in this manual. The manufacturer accepts no liability for damage or injury resulting from misuse of this machine.

Compliance with the conditions of operation, service and repair as specified by the manufacturer constitute essential elements for the intended use of this machine.

This machine should be operated, serviced and repaired only by qualified persons familiar with its characteristics and familiar with the relevant safety rules and procedures.

All generally recognized safety regulations and road traffic regulations must be obeyed at all times.

Any unauthorized modifications performed on this machine will relieve the manufacturer of all liability for any resulting damage or injury.

1.1.7 Proper disposal of waste

Improper disposal of waste can pollute the environment and ecology. A few examples of potentially harmful equipment waste can include, but not limited to, items such as oil, fuel, coolant, brake fluid, filters, battery chemicals, tires, etc.

Use leak proof containers when draining fluids. Do not use food or beverage containers to collect waste fluids, as food or beverage container(s) may mislead someone into drinking from them.

Do not pour or spill waste onto the ground, down a drain, or into any water source.

Air conditioning refrigerants escaping into the air can damage the Earth's atmosphere. Government regulations may require a certified air conditioning service center to recover and recycle used air conditioning refrigerants.

Inquire with local environmental or recycling center on the proper way to recycle or dispose waste.

1.1.8 Weld on the machine precautions

Before you weld on the machine:

- Disconnect battery terminals and put them out of the way.
- Disconnect all controllers and monitors.
- Connect the welding ground as close as possible to weld area.

If you do not disconnect the electrical components, the component can be damaged.

When you connect the electrical connections, connect the battery cables last.

1.2 Safety

1.2.1 Introduction

1.2.1.1 Safety symbol

The safety symbol tells you about a potentially hazardous area!

Look for the safety symbol in this manual and on the machine. The safety symbols tell you that there is important safety instructions in the manual.



Fig. 2

1.2.1.2 Safety messages

The words DANGER, WARNING or CAUTION are used with the safety symbol. Learn these safety messages and obey the recommended precautions and safety instructions.



DANGER:

If you do not obey the recommended precautions and safety instructions, DEATH OR INJURY will occur.



WARNING:

If you do not obey the recommended precautions and safety instructions, DEATH OR INJURY can occur.



CAUTION:

If you do not obey the recommended precautions and safety instructions, INJURY can possibly occur.



Fig. 3

1.2.1.3 Information messages

The words important and note are not related to personal safety, and are used to give information about the operation and servicing of the machine.

IMPORTANT: Identifies special instructions or procedures which, if not followed, can cause damage to the machine, the process, or the area around the machine.

NOTE: Information to make procedures easier.

1.2.1.4 Safety signs



WARNING:

Do not remove the safety signs. Replace safety signs that you cannot read, are damaged, or are missing.

Clean the machine surface with a weak soap and water solution before you replace the safety signs. Replacement safety signs are available from your dealer.

Always make sure that safety signs are in the correct locations and that you can read the safety signs. Illustrations of safety sign locations are at in this section.

Keep the safety signs clean. If necessary, use a weak soap and water solution.

1.2.1.5 A word to the technician

Read and understand the safety section in this service manual before operating or servicing the machine. Read and understand the safety sections in the manuals for all attachments before operating or servicing attachments. The technician has the key to safety. Good safety practices protect everyone.

Study the safety information in this service manual. Make the safety information a working part of the safety program. The safety information in this service manual applies specifically to this type of machine. Always do all other usual and customary safe working precautions. Remember - The technician has the responsibility for safety. Good safety practices can prevent serious injury or death.

The safety section points out some basic safety situations that can occur during the operation and maintenance of the machine. The safety section also suggests possible ways to deal with these situations. The safety section does not replace safety practices in other parts of this service manual.

Practice good safety to help prevent injury or death.

Learn how to operate the machine and how to use the controls correctly.

Do not let other persons operate the machine without instruction and training.

Follow all safety precautions and instructions in the manuals and on safety signs affixed to the machine and all attachments.

Use only approved attachments and equipment.

Make sure the machine has the correct equipment needed by the local regulations.

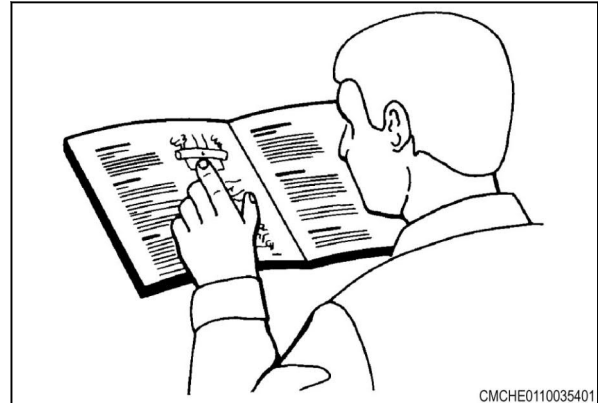

Fig. 4



WARNING:

An operator should not use alcohol or drugs which can affect their alertness or coordination. An operator on prescription or 'over the counter' drugs needs medical advice on whether or not they can properly operate machines. If any attachments used on this equipment have a separate Operator Manual, see that manual for other important safety information.

1.2.1.6 The service manual

Read the table of contents and basic layout. Become familiar with all parts of this service manual. This service manual gives the technician very important information.

Machine movement when in normal use determines right-hand and left-hand.

This manual covers general safety practices for this machine.

The photos, illustrations, and data used in this manual were current at the time of printing. Inline production changes can make machines vary from the information in the service manual. The manufacturer reserves the right to redesign and change the machine as necessary without notification.



WARNING:

In some of the illustrations and photos used in this manual, shields or guards may have been removed for clarity. Never operate the machine with any shields or guards removed. If the removal of shields or guards is necessary to make a repair, they must be replaced before operation.

1.2.2 Operation

1.2.2.1 Prepare for operation

Read and understand the operating instructions and precautions in this manual before you operate or perform service on the machine.

Make sure that you know and understand the positions and operations of all controls. Make sure that all controls are in neutral and the parking brake is applied before you start the machine.

Make sure that all persons are a sufficient distance from your area of work before you start or operate the machine. Do checks on the controls and learn all controls in an area clear of persons and objects before you start work with the machine. Know the dimensions of the machine and have sufficient space available for operation. Do not operate the machine at high speeds around persons, buildings, other equipment, etc.

Always use correct procedures when you do tasks around and operate the machine. Do not let children or persons who do not know how to operate the machine operate the machine. Keep other persons away from your area of work. Do not let other persons ride on the machine.

Make sure that the machine is in the good mechanical condition. Make sure that the machine has the correct equipment as necessary by local regulations.

All equipment has a limit. Make sure you understand the speed, brakes, steering, stability, and load characteristics of this equipment before you start.

1.2.2.2 General information

When parking, park the machine on a solid level surface and lower the header to the ground. Put all controls in neutral, and apply the parking brake. Stop the engine and take the key with you.



WARNING: Whole body crushing hazard. A loss of hydraulic pressure or movement of the mechanism can cause the raised machine component to fall.

Personal injury or death can occur.

Install the lift cylinder stops before working on the machine to prevent movement.

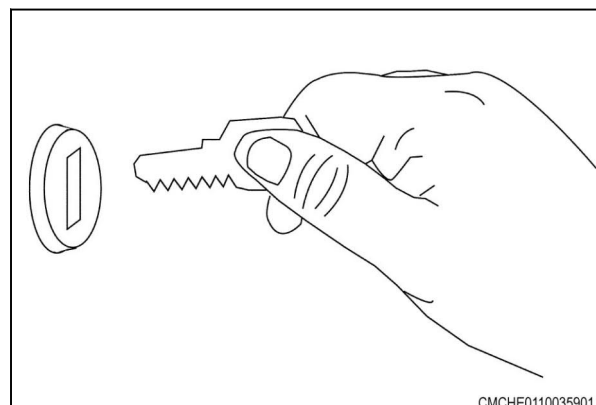

Fig. 5

CMCHE0110035901

Make sure the machine is in the proper operating condition according to the Operator Manual.

Always operate the machine with the control console turned on.

Do not dismount from moving machinery.

Stay off slopes too steep for operation.

Be aware of the size of the machine and have enough space available to allow for operation.

Stay off slopes too steep for operation. Keep the header as low as possible while going down hills. Never suddenly reverse the wheels to stop or back up.

Where possible avoid operating the machine near ditches, embankments, and holes. Reduce ground speed when operating on rough, slippery, or muddy surfaces and when turning or crossing slopes.



DANGER: Machine electrical shock and electrocution hazard.

Personal injury or death can occur.

Keep the machine clear of overhead electrical power lines.

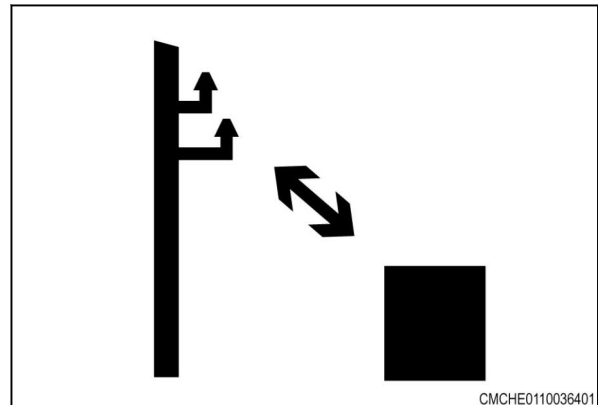

Fig. 6

1.2.2.3 Personal protective equipment

Put on all personal protective equipment (PPE) and protective clothes that are supplied to you or that are necessary for the conditions and by applicable laws. PPE includes equipment to prevent injury to your eyes, lungs, ears, head, hands and feet.

Always keep hands, feet, hair, and your clothes away from parts that move. Do not put on loose clothing, jewelry, watches, or other items that can tangle in parts that move. Tie up long hair that can also tangle in moving parts.

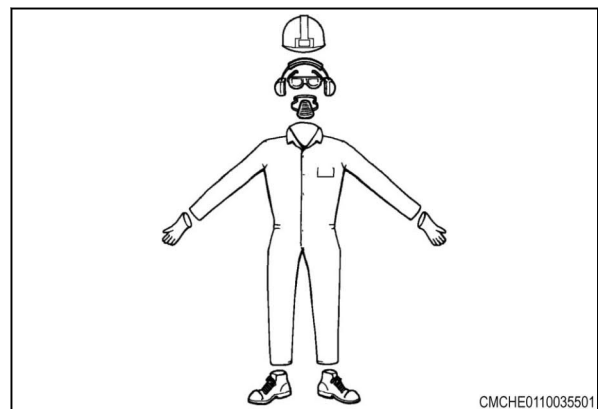

Fig. 7

1.2.2.4 Seat instructions

Put on the seat belt before you operate the machine. Always sit in the seat and have the seat belt on while you operate the machine. Replace the seat belts when they become worn or broken.

Do not use a seat belt loosely. Make sure that there is some tension on the seat belt. Do not wear the seat belt in a twisted condition or pinched between the structural parts of the seat.

Put on the seat belt if the instructional seat is used. Use the instructional seat only to train new operators or to find a problem. The instructional seat is only for short periods of use.

Do not let children use the instructional seat or be in the cab. Do not let other persons use the instructional seat or be in the cab.

Drive the machine at slower speed and on level ground when the instructional seat is used. Do not start, stop, or turn quickly when the instructional seat is used. Do not drive on highways or public roads when the instructional seat is used.

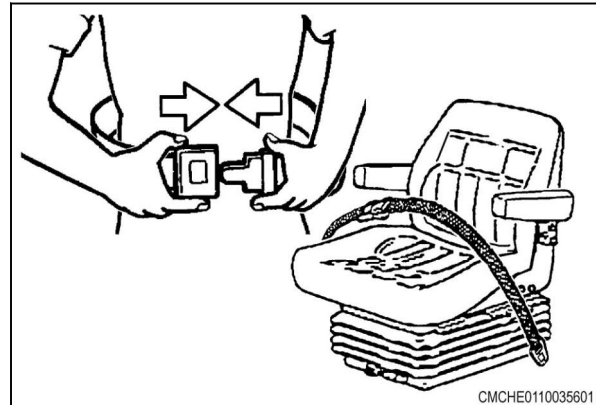

Fig. 8

1.2.2.5 Shield and guards



**WARNING: Entanglement hazard.
Belts and components that rotate.**

Severe personal injury or death can occur.

Do not open, remove, or put your hand behind shields if the engine is running. Stop the machine before doing service to the machine.

All shields and guards must be in the correct position and in good condition. Keep away from the components that rotate.

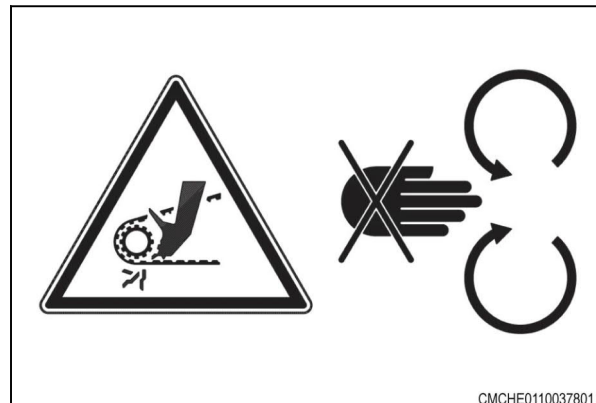

Fig. 9



**DANGER: Entanglement hazard.
Rotating components.**

Severe personal injury or death can occur.

Do not make adjustments or repairs to components while they are moving. Stop the machine before doing service to the machine.

Do not operate the machine with the drive shaft shields open or removed.

Keep away from the components that turn.

Make sure guards that turn are free.

Do not make adjustments to the roll tension with the header engaged.



Fig. 10



Suggest:

For more complete manuals. Please go to the home page.

<https://www.ebooklibonline.com>

If the above button click is invalid. Please download this document first, and then click the above link to download the complete manual.

Thank you so much for reading

When you make adjustments to the roll pressure, stop the header. Engage the parking brake.

1.2.2.6 Power take-off safety

Keep all shields in place.

The rear power take-off (PTO) master shield (1) must be correctly installed at all times. The PTO shaft cover(s) must be installed when the PTO driveline is not in use.

Do not use PTO adapters. PTO shaft adapters, reducers and/or extensions extend the implement drive shaft coupler and universal joint beyond the protection of the PTO master shield.

Reduce PTO speed slowly. When stopping any PTO driven machine, idle the engine to reduce the PTO speeds before disengaging.

The implement drive shaft coupler (1) must securely lock to, and be retained by the annular groove on the tractor PTO shaft.

Always disengage the PTO, park the tractor, shut off the engine and remove the key before:

- Connecting or disconnecting the implement drive shaft.
- Adjusting the PTO driveline or PTO driven machine.
- Cleaning, unplugging, or servicing the PTO driven machine.

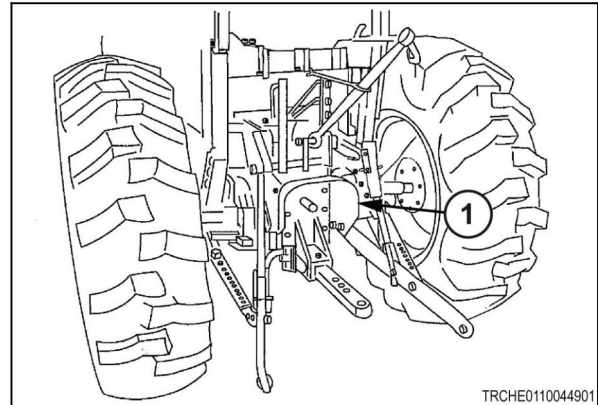

Fig. 11

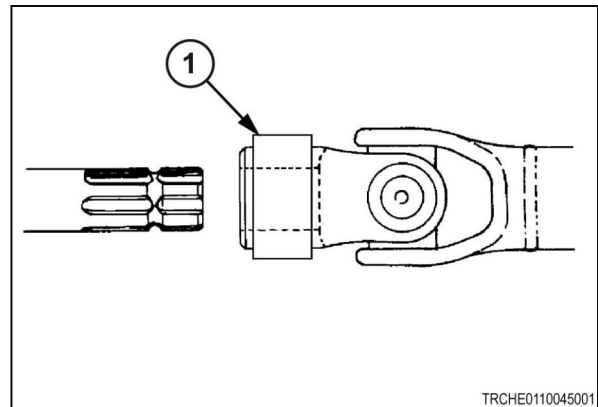

Fig. 12

1.2.2.7 Exhaust warning



WARNING: Inhalation hazard. Exhaust gases.

Death or serious illness can occur.

Do not operate the engine in a closed building unless the exhaust is ventilated to the outside.

Do not tamper with or modify the exhaust system with unapproved extensions.

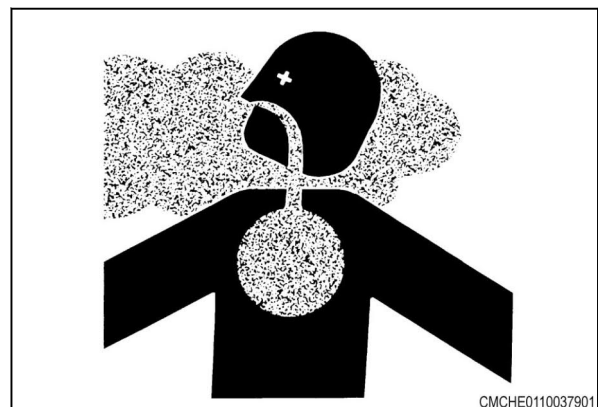

Fig. 13

1.2.2.8 Flying debris



WARNING:
 Be careful when you operate along the side of a road or structures. Rocks and other materials can be thrown from the machine during operation and can cause injury. If there are rocks and unwanted objects in a field, tilt the header up. This will lift the knives and reduce other materials thrown by the knives.

Stay away from the machine during operation. Some materials can be thrown from the machine during operation and cause injury.



Fig. 14

1.2.2.9 Agricultural chemicals

Agricultural chemicals are very dangerous. Incorrect procedures with fertilizer, fungicides, herbicides, insecticides and pesticides can cause injuries to plants, animals, soil and other persons property.

Always read and follow all manufacturers instructions before you open chemical containers.

Read and follow instructions each time you use a chemical.

Use the same precautions when you do adjustments, do servicing, clean or store the machine as used when you put chemicals into the hoppers or tanks.

Tell all persons who are near chemicals of the possible dangerous results and the safety precautions that are necessary.

Stay upwind and away from smoke from a chemical fire.

Keep or discard all chemicals that are not used as specified by the chemical manufacturer.

1.2.2.10 Travel on public roads

Make sure that you understand the speed, brakes, steering, load characteristics, and how to keep the machine stable before you operate on public roads.

Use good judgment when you operate the machine on public roads. Keep complete control of the machine at all times. Do not coast on downhills.

The maximum speed of farm equipment is set by local regulations. Adjust speed to keep control at all times.

Make sure that the machine is in good condition for operation. Refer to the operator manual.

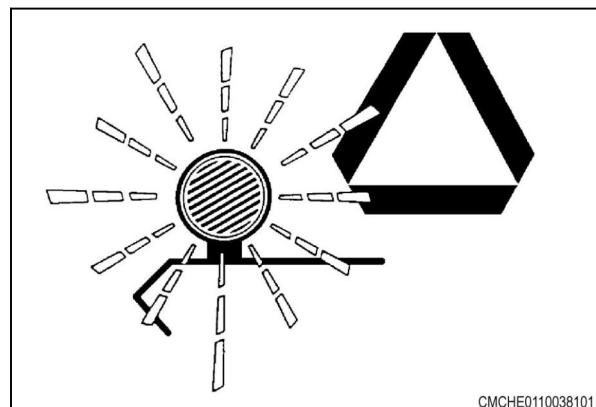

Fig. 15

The tractor must have sufficient weight and braking capacity, especially when you operate on roads and terrain that is not smooth. Use a tractor of sufficient dimensions and weight to tow the machine.

Make sure that you understand and obey all road regulations that apply to your machine. See your local law enforcement agency for local regulations about movement of farm equipment on public roads. Use head lamps, flashing warning lamps, rear lamps and turn signals, day and night, unless prohibited by local law.

<https://www.ebooklibonline.com>

Hello dear friend!

Thank you very much for reading.

Enter the link into your browser.

The full manual is available for immediate download.

<https://www.ebooklibonline.com>