

Product: EXCAVATOR

Model: M315 EXCAVATOR 7ML

Configuration: M315 Excavator 7ML00001-00859 (MACHINE) POWERED BY 3054 Engine

Operation and Maintenance Manual M312 and M315 Excavators

Media Number -SEBU6933-05

Publication Date -01/04/2014

Date Updated -10/04/2014

s00037320

Foreword

Literature Information

This manual should be stored in the operator's compartment in the literature holder or seat back literature storage area.

This manual contains safety information, operation instructions, transportation information, lubrication information and maintenance information.

Some photographs or illustrations in this publication show details or attachments that can be different from your machine. Guards and covers might have been removed for illustrative purposes.

Continuing improvement and advancement of product design might have caused changes to your machine which are not included in this publication. Read, study and keep this manual with the machine.

Whenever a question arises regarding your machine, or this publication, please consult your Cat dealer for the latest available information.

Safety

The safety section lists basic safety precautions. In addition, this section identifies the text and locations of warning signs and labels used on the machine.

Read and understand the basic precautions listed in the safety section before operating or performing lubrication, maintenance and repair on this machine.

Operation

The operation section is a reference for the new operator and a refresher for the experienced operator. This section includes a discussion of gauges, switches, machine controls, attachment controls, transportation and towing information.

Photographs and illustrations guide the operator through correct procedures of checking, starting, operating and stopping the machine.

Operating techniques outlined in this publication are basic. Skill and techniques develop as the operator gains knowledge of the machine and its capabilities.

Maintenance

The maintenance section is a guide to equipment care. The Maintenance Interval Schedule (MIS) lists the items to be maintained at a specific service interval. Items without specific intervals are listed under the "When Required" service interval. The Maintenance Interval Schedule lists the page number for the step-by-step instructions required to accomplish the scheduled maintenance. Use the Maintenance Interval Schedule as an index or "one safe source" for all maintenance procedures.

Maintenance Intervals

Use the service hour meter to determine servicing intervals. Calendar intervals shown (daily, weekly, monthly, etc.) can be used instead of service hour meter intervals if they provide more convenient servicing schedules and approximate the indicated service hour meter reading. Recommended service should always be performed at the interval that occurs first.

Under extremely severe, dusty or wet operating conditions, more frequent lubrication than is specified in the maintenance intervals chart might be necessary.

Perform service on items at multiples of the original requirement. For example, at every 500 service hours or 3 months, also service those items listed under every 250 service hours or monthly and every 10 service hours or daily.

California Proposition 65 Warning

Diesel engine exhaust and some of its constituents are known to the State of California to cause cancer, birth defects, and other reproductive harm.

Battery posts, terminals and related accessories contain lead and lead compounds. **Wash hands after handling.**

Certified Engine Maintenance

Proper maintenance and repair is essential to keep the engine and machine systems operating correctly. As the heavy duty off-road diesel engine owner, you are responsible for the performance of the required maintenance listed in the Owner Manual, Operation and Maintenance Manual, and Service Manual.

It is prohibited for any person engaged in the business of repairing, servicing, selling, leasing, or trading engines or machines to remove, alter, or render inoperative any emission related device or element of design installed on or in an engine or machine that is in compliance with the regulations (40 CFR Part 89). Certain elements of the machine and engine such as the exhaust system, fuel system, electrical system, intake air system and cooling system may be emission related and should not be altered unless approved by Caterpillar.

Machine Capacity

Additional attachments or modifications may exceed machine design capacity which can adversely affect performance characteristics. Included would be stability and system certifications such as brakes, steering, and rollover protective structures (ROPS). Contact your Cat dealer for further information.

Cat Product Identification Number

Effective First Quarter 2001 the Cat Product Identification Number (PIN) has changed from 8 to 17 characters. In an effort to provide uniform equipment identification, Caterpillar and other construction equipment manufacturers are moving to comply with the latest version of the product identification numbering standard. Non-road machine PINs are defined by ISO 10261. The new PIN format will apply to all Cat machines and generator sets. The PIN plates and frame marking will display the 17 character PIN. The new format will look like the following:



Illustration 1

g00751314

Where:

1. Caterpillar's World Manufacturing Code (characters 1-3)
2. Machine Descriptor (characters 4-8)
3. Check Character (character 9)
4. Machine Indicator Section (MIS) or Product Sequence Number (characters 10-17). These were previously referred to as the Serial Number.

Machines and generator sets produced before First Quarter 2001 will maintain their 8 character PIN format.

<https://www.ebooklibonline.com>

Hello dear friend!

Thank you very much for reading.

Enter the link into your browser.

The full manual is available for immediate download.

<https://www.ebooklibonline.com>

Components such as engines, transmissions, axles, etc. and work tools will continue to use an 8 character Serial Number (S/N).

Product: EXCAVATOR

Model: M315 EXCAVATOR 7ML

Configuration: M315 Excavator 7ML00001-00859 (MACHINE) POWERED BY 3054 Engine

Operation and Maintenance Manual M312 and M315 Excavators

Media Number -SEBU6933-05

Publication Date -01/04/2014

Date Updated -10/04/2014

i01049309

Safety Signs and Labels

SMCS - 7000; 7405

There are several specific safety signs on this machine. The exact location of the hazards and the description of the hazards are reviewed in this section. Please become familiarized with all safety signs.

Make sure that all of the safety signs are legible. Clean the safety signs or replace the safety signs if you cannot read the words. Replace the illustrations if the illustrations are not visible. When you clean the safety signs, use a cloth, water and soap. Do not use solvent, gasoline, or other harsh chemicals to clean the safety signs. Solvents, gasoline, or harsh chemicals could loosen the adhesive that secures the safety sign. Loose adhesive will allow the safety sign to fall.

Replace any safety sign that is damaged, or missing. If a safety sign is attached to a part that is replaced, install a safety sign on the replacement part. Any Caterpillar dealer can provide new safety signs.

Do Not Operate

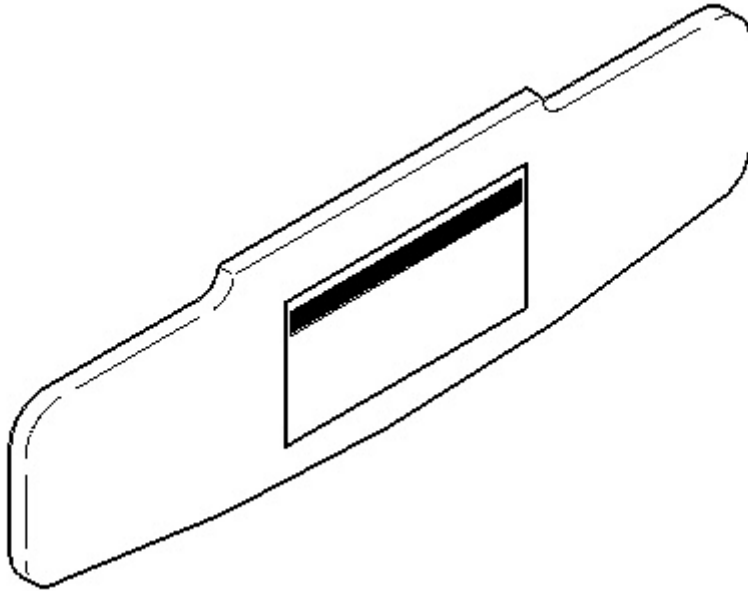

Illustration 1

g00330103

This warning label is located on either side of the sun visor.



g00103591



Do not operate or work on this machine unless you have read and understand the instructions and warnings in the Operation and Maintenance Manuals. Failure to follow the instructions or heed the warnings could result in injury or death. Contact any Caterpillar dealer for replacement manuals. Proper care is your responsibility.

Certification of the Falling Object Protective Structure

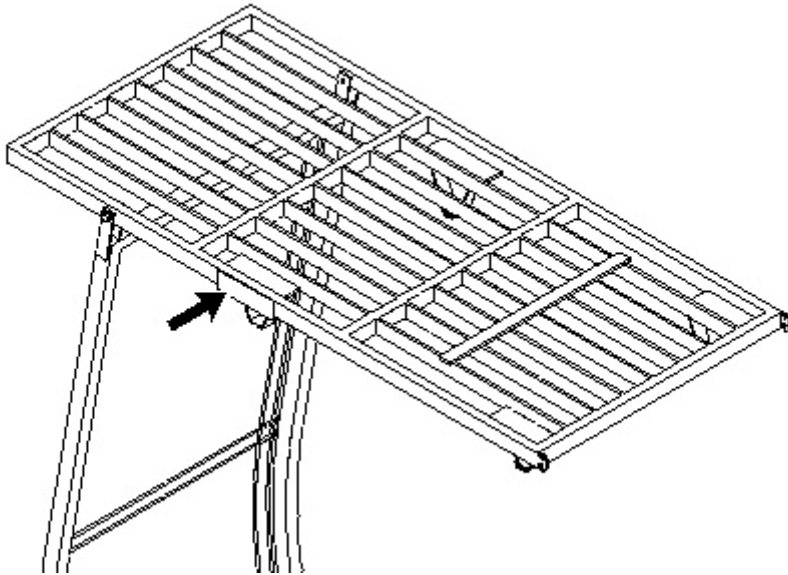

Illustration 2

g00330163

This warning is located on the overhead guard (if equipped).

⚠ WARNING	
<small>STRUCTURAL DAMAGE, AN OVERTURN, MODIFICATION, ALTERATION, OR IMPROPER REPAIR CAN IMPAIR THIS STRUCTURE'S PROTECTION CAPABILITY THEREBY VOIDING THIS CERTIFICATION. DO NOT WELD ON OR DRILL HOLES IN THE STRUCTURE. CONSULT A CATERPILLAR DEALER TO DETERMINE THIS STRUCTURE'S LIMITATIONS WITHOUT VOIDING ITS CERTIFICATION.</small>	
FALLING OBJECT (FOPS) PROTECTIVE STRUCTURE CERTIFICATION THIS STRUCTURE, WHEN PROPERLY INSTALLED ON A MACHINE MEETS, AT THE TIME OF INSTALLATION, CRITERIA ESTABLISHED BY: TOP GUARD: SAE J1360 FEB 00, ISO 3449: 1992 LEVEL II	MODEL NO. M312 M315 M316 M320 CATERPILLAR INC. PEORIA, ILLINOIS USA 117-9549 1

g00103593



Structural damage, an overturn, modification, alteration, or improper repair can impair this structure's protection capability thereby voiding this certification. Do not weld on or drill holes in the structure. Consult a Caterpillar dealer to determine this structure's limitations without voiding its certification.

Improper Connections for Jump Start Cables



Illustration 3

g00103595

This warning is located on the battery box.

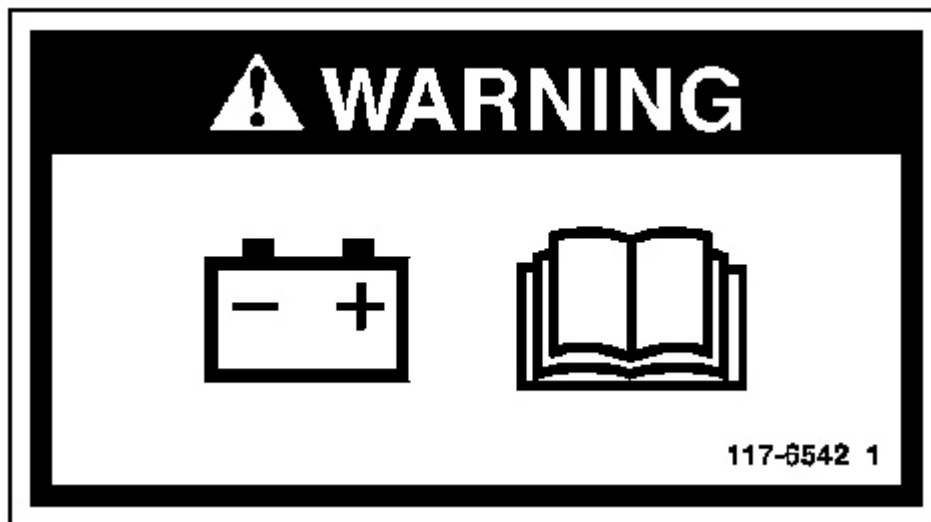

g00104283

Read Operation and Maintenance Manual, "Starting with Jump Start Cables" before attempting to jump start your machine.

Reversed Control Functions



Illustration 4

g00103597

This warning is located in the cab.



g00103797



FUNCTIONS OF STEERING AND TRANSMISSION DIRECTION CONTROLS ARE REVERSED WHEN BOOM IS OVER REAR AXLE.

FAILURE TO PROPERLY CONTROL MACHINE CAN RESULT IN PERSONAL INJURY.

Automatic Engine Control (AEC)



Illustration 5

g00103802

This warning label is positioned in the cab.

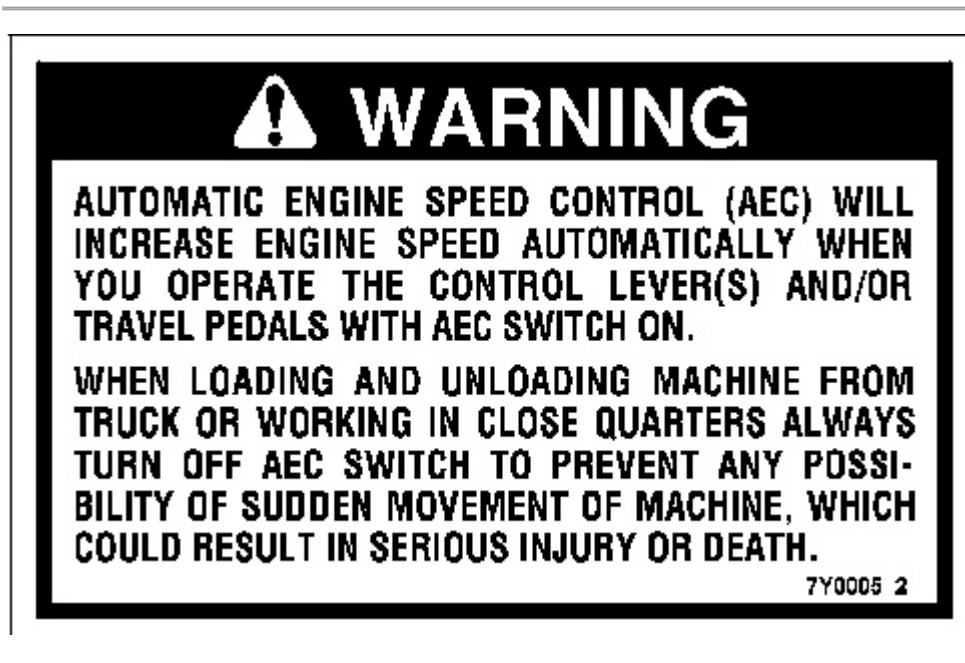

g00100749



Automatic Engine Speed Control (AEC) will increase engine speed automatically when you operate the control lever(s) and/or travel pedals with AEC switch ON.

When loading and unloading machine from truck or working in close quarters always turn off AEC switch to prevent any possibility of sudden movement of machine, which could result in serious injury or death.

Air Inlet Heater (S/N: 5HK; 9RM)



Illustration 6

g00304965

This warning label is located on the engine.



g00100745

Do not spray ether into the engine air intake.

Air Inlet Heater (S/N: 7BJ)



Illustration 7

g00518748

This warning label is located on the engine.



g00100745

Do not spray ether into the engine air intake.

Product: EXCAVATOR

Model: M315 EXCAVATOR 7ML

Configuration: M315 Excavator 7ML00001-00859 (MACHINE) POWERED BY 3054 Engine

Operation and Maintenance Manual M312 and M315 Excavators

Media Number -SEBU6933-05

Publication Date -01/04/2014

Date Updated -10/04/2014

i00994424

General Hazard Information

SMCS - 7000



Illustration 1

g00102311

Attach a "Do Not Operate" warning tag or a similar warning tag to the start switch or to the controls before you service the machine or before you repair the machine. These warning tags (Special Instruction, SEHS7332) are available from your Caterpillar dealer.

Know the width of your implement in order to maintain proper clearance when you operate the machine near fences or near boundary obstacles.

Wear a hard hat, protective glasses, and other protective equipment, as required.

Do not wear loose clothing or jewelry that can snag on controls or on other parts of the machine.

Make sure that all protective guards and all covers are secured in place on the machine.

Keep the machine free from foreign material. Remove debris, oil, tools, and other items from the deck, from walkways, and from steps.

Secure all loose items such as lunch boxes, tools, and other items that are not a part of the machine.

Know the appropriate work site hand signals and the personnel that are authorized to give the hand signals. Accept hand signals from one person only.

Do not smoke when you service an air conditioner. Also, do not smoke if refrigerant gas may be present. Inhaling the fumes that are released from a flame that contacts air conditioner refrigerant can cause bodily harm or death. Inhaling gas from air conditioner refrigerant through a lighted cigarette can cause bodily harm or death.

Never put maintenance fluids into glass containers. Drain all liquids into a suitable container.

Obey all local regulations for the disposal of liquids.

Use all cleaning solutions with care. Report all necessary repairs.

Do not allow unauthorized personnel on the machine.

Unless you are instructed otherwise, perform the maintenance under the following conditions:

- The machine is parked on level ground.
- The implement is lowered to the ground.
- The implement control levers are in the HOLD position.
- The left console is raised so that the hydraulic system is disengaged.
- The engine is stopped.
- The engine start switch is turned to the OFF position and the engine start switch key is removed.
- The battery disconnect switch is in the OFF position and the disconnect switch key is removed.

Pressure Air

Pressure air can cause personal injury. When pressure air is used for cleaning, wear a protective face shield, protective clothing, and protective shoes.

The maximum air pressure for cleaning purposes must be below 205 kPa (30 psi).

Fluid Penetration

Pressure can be maintained in the hydraulic circuit long after the engine has been stopped. The pressure can cause hydraulic fluid or items such as pipe plugs to escape rapidly if the pressure is not relieved correctly.

Do not remove any hydraulic components or parts until pressure has been relieved or personal injury may occur. Do not disassemble any hydraulic components or parts until pressure has been relieved or personal injury may occur.

Perform the following procedures in order to relieve pressure:

1. Lower the bucket or equipment to the ground.
2. Stop the engine.
3. With the operator in the seat, move the left console to the RAISED position.
4. Actuate an implement control lever about ten times in order to dissipate the pressure in the hydraulic circuit.
5. Raise the left console.

Always use a board or cardboard when you check for a leak. Leaking fluid that is under pressure can penetrate body tissue. Fluid penetration can cause serious injury and possible death. A pin hole leak can cause severe injury. If fluid is injected into your skin, you must get treatment immediately. Seek treatment from a doctor that is familiar with this type of injury.

Containing Fluid Spillage

All fluids must be contained during the following procedures: inspections, maintenance, testing, adjusting and repair. Allow all fluids to drain into a suitable container.

Refer to Special Publication, NENG2500, "Tools and Shop Products Guide" for the suitable tools and the suitable supplies.

Dispose of used fluids according to local regulations.

Asbestos Information

Caterpillar equipment and replacement parts that are shipped from Caterpillar are asbestos free. Caterpillar recommends the use of only genuine Caterpillar replacement parts. Use the following guidelines when you handle any replacement parts that contain asbestos or when you handle asbestos debris.

Use caution. Avoid inhaling dust that might be generated when you handle components that contain asbestos fibers. Inhaling this dust can be hazardous to your health. The components that may contain asbestos fibers are brake pads, brake bands, lining material, clutch plates, and some gaskets. The asbestos that is used in these components is usually bound in a resin or sealed in some way. The normal handling is not hazardous unless airborne dust that contains asbestos is generated.

If dust which may contain asbestos is present, there are several guidelines that should be followed.

Never use compressed air for cleaning. Avoid the brushing or the grinding of materials that contain asbestos. Use a wet method to clean up asbestos debris. A vacuum that is equipped with a high efficiency particulate air filter (HEPA) can also be used.

Use exhaust ventilation on permanent machining jobs.

Wear an approved respirator if there is no other way to control the dust.

Comply with applicable rules and regulations for the work place. In the USA, use Occupational Safety and Health Administration requirements. These OSHA requirements can be found in "29 CFR 1910.1001".

Obey environmental regulations for disposal of asbestos.

Stay away from areas that might have asbestos particles in the air.

Product: EXCAVATOR

Model: M315 EXCAVATOR 7ML

Configuration: M315 Excavator 7ML00001-00859 (MACHINE) POWERED BY 3054 Engine

Operation and Maintenance Manual M312 and M315 Excavators

Media Number -SEBU6933-05

Publication Date -01/04/2014

Date Updated -10/04/2014

i01359664

Crushing Prevention and Cutting Prevention

SMCS - 7000

Support the equipment properly before you perform any work or maintenance beneath that equipment. Do not depend on the hydraulic cylinders to hold up the equipment. Equipment can fall if a control is moved, or if a hydraulic line breaks.

Do not work beneath the cab of the machine unless the cab is properly supported.

Unless you are instructed otherwise, never attempt adjustments while the machine is moving or while the engine is running.

Never jump across the starter solenoid terminals in order to start the engine. Unexpected machine movement could result.

Whenever there are equipment control linkages the clearance in the linkage area will change with the movement of the equipment or the machine. Stay clear of areas that may have a sudden change in clearance with machine movement or equipment movement.

Stay clear of all rotating and moving parts.

If it is necessary to remove guards in order to perform maintenance, always install the guards after the maintenance is performed.

Keep objects away from moving fan blades. The fan blade will throw objects or cut objects.

Do not use a kinked wire cable or a frayed wire cable. Wear gloves when you handle wire cable.

When you strike a retainer pin with force, the retainer pin can fly out. The loose retainer pin can injure personnel. Make sure that the area is clear of people when you strike a retainer pin. To avoid injury to your eyes, wear protective glasses when you strike a retainer pin.

Chips or other debris can fly off an object when you strike the object. Make sure that no one can be injured by flying debris before striking any object.



Suggest:

For more complete manuals. Please go to the home page.

<https://www.ebooklibonline.com>

If the above button click is invalid. Please download this document first, and then click the above link to download the complete manual.

Thank you so much for reading

Product: EXCAVATOR

Model: M315 EXCAVATOR 7ML

Configuration: M315 Excavator 7ML00001-00859 (MACHINE) POWERED BY 3054 Engine

Operation and Maintenance Manual M312 and M315 Excavators

Media Number -SEBU6933-05

Publication Date -01/04/2014

Date Updated -10/04/2014

i04760300

Burn Prevention

SMCS - 7000

Do not touch any part of an operating engine. Allow the engine to cool before any maintenance is performed on the engine. Relieve all pressure in the air system, in the oil system, in the lubrication system, in the fuel system, or in the cooling system before any lines, fittings, or related items are disconnected.

Coolant

When the engine is at operating temperature, the engine coolant is hot. The coolant is also under pressure. The radiator and all lines to the heaters or to the engine contain hot coolant.

Any contact with hot coolant or with steam can cause severe burns. Allow cooling system components to cool before the cooling system is drained.

Check the coolant level only after the engine has been stopped.

Ensure that the filler cap is cool before removing the filler cap. The filler cap must be cool enough to touch with a bare hand. Remove the filler cap slowly in order to relieve pressure.

Cooling system conditioner contains alkali. Alkali can cause personal injury. Do not allow alkali to contact the skin, the eyes, or the mouth.

Oils

Hot oil and hot components can cause personal injury. Do not allow hot oil to contact the skin. Also, do not allow hot components to contact the skin.

Remove the hydraulic tank filler cap only after the engine has been stopped. The filler cap must be cool enough to touch with a bare hand. Follow the standard procedure in this manual in order to remove the hydraulic tank filler cap.

Batteries

The liquid in a battery is an electrolyte. Electrolyte is an acid that can cause personal injury. Do not allow electrolyte to contact the skin or the eyes.

Do not smoke while checking the battery electrolyte levels. Batteries give off flammable fumes which can explode.

Always wear protective glasses when you work with batteries. Wash hands after touching batteries. The use of gloves is recommended.

<https://www.ebooklibonline.com>

Hello dear friend!

Thank you very much for reading.

Enter the link into your browser.

The full manual is available for immediate download.

<https://www.ebooklibonline.com>