

Product: EXCAVATOR

Model: 315B L EXCAVATOR 5SW

Configuration: 315B L Excavator 5SW00001-UP (MACHINE) POWERED BY 3054 Engine

## **Operation and Maintenance Manual 307B, 312B, 315B, 317B and 318B Excavators**

Media Number -SEBU7500-04

Publication Date -01/03/2001

Date Updated -16/11/2001

s00037320

## **Foreword**

SMCS - 6001-011; 6001; 6101; 6102; 6523

## **Literature Information**

This manual should be stored in the operator's compartment in the literature holder or seat back literature storage area.

This manual contains safety information, operation instructions, transportation information, lubrication information and maintenance information.

Some photographs or illustrations in this publication show details or attachments that can be different from your machine. Guards and covers might have been removed for illustrative purposes.

Continuing improvement and advancement of product design might have caused changes to your machine which are not included in this publication. Read, study and keep this manual with the machine.

Whenever a question arises regarding your machine, or this publication, please consult your Cat dealer for the latest available information.

## **Safety**

The safety section lists basic safety precautions. In addition, this section identifies the text and locations of warning signs and labels used on the machine.

Read and understand the basic precautions listed in the safety section before operating or performing lubrication, maintenance and repair on this machine.

## **Operation**

The operation section is a reference for the new operator and a refresher for the experienced operator. This section includes a discussion of gauges, switches, machine controls, attachment controls, transportation and towing information.

Photographs and illustrations guide the operator through correct procedures of checking, starting, operating and stopping the machine.

Operating techniques outlined in this publication are basic. Skill and techniques develop as the operator gains knowledge of the machine and its capabilities.

## Maintenance

The maintenance section is a guide to equipment care. The Maintenance Interval Schedule (MIS) lists the items to be maintained at a specific service interval. Items without specific intervals are listed under the "When Required" service interval. The Maintenance Interval Schedule lists the page number for the step-by-step instructions required to accomplish the scheduled maintenance. Use the Maintenance Interval Schedule as an index or "one safe source" for all maintenance procedures.

### Maintenance Intervals

Use the service hour meter to determine servicing intervals. Calendar intervals shown (daily, weekly, monthly, etc.) can be used instead of service hour meter intervals if they provide more convenient servicing schedules and approximate the indicated service hour meter reading. Recommended service should always be performed at the interval that occurs first.

Under extremely severe, dusty or wet operating conditions, more frequent lubrication than is specified in the maintenance intervals chart might be necessary.

Perform service on items at multiples of the original requirement. For example, at every 500 service hours or 3 months, also service those items listed under every 250 service hours or monthly and every 10 service hours or daily.

## California Proposition 65 Warning

Diesel engine exhaust and some of its constituents are known to the State of California to cause cancer, birth defects, and other reproductive harm.

Battery posts, terminals and related accessories contain lead and lead compounds. **Wash hands after handling.**

## Certified Engine Maintenance

Proper maintenance and repair is essential to keep the engine and machine systems operating correctly. As the heavy duty off-road diesel engine owner, you are responsible for the performance of the required maintenance listed in the Owner Manual, Operation and Maintenance Manual, and Service Manual.

It is prohibited for any person engaged in the business of repairing, servicing, selling, leasing, or trading engines or machines to remove, alter, or render inoperative any emission related device or element of design installed on or in an engine or machine that is in compliance with the

regulations (40 CFR Part 89). Certain elements of the machine and engine such as the exhaust system, fuel system, electrical system, intake air system and cooling system may be emission related and should not be altered unless approved by Caterpillar.

## Machine Capacity

Additional attachments or modifications may exceed machine design capacity which can adversely affect performance characteristics. Included would be stability and system certifications such as brakes, steering, and rollover protective structures (ROPS). Contact your Cat dealer for further information.

## Cat Product Identification Number

Effective First Quarter 2001 the Cat Product Identification Number (PIN) has changed from 8 to 17 characters. In an effort to provide uniform equipment identification, Caterpillar and other construction equipment manufacturers are moving to comply with the latest version of the product identification numbering standard. Non-road machine PINs are defined by ISO 10261. The new PIN format will apply to all Cat machines and generator sets. The PIN plates and frame marking will display the 17 character PIN. The new format will look like the following:



---

Illustration 1

g00751314

Where:

1. Caterpillar's World Manufacturing Code (characters 1-3)
2. Machine Descriptor (characters 4-8)
3. Check Character (character 9)
4. Machine Indicator Section (MIS) or Product Sequence Number (characters 10-17). These were previously referred to as the Serial Number.

**<https://www.ebooklibonline.com>**

Hello dear friend!

Thank you very much for reading.

Enter the link into your browser.

The full manual is available for immediate download.

**<https://www.ebooklibonline.com>**

Machines and generator sets produced before First Quarter 2001 will maintain their 8 character PIN format.

Components such as engines, transmissions, axles, etc. and work tools will continue to use an 8 character Serial Number (S/N).

---

Product: EXCAVATOR

Model: 315B L EXCAVATOR 5SW

Configuration: 315B L Excavator 5SW00001-UP (MACHINE) POWERED BY 3054 Engine

## **Operation and Maintenance Manual 307B, 312B, 315B, 317B and 318B Excavators**

Media Number -SEBU7500-04

Publication Date -01/03/2001

Date Updated -16/11/2001

i01495034

### **Model View Illustrations - VA Boom**

SMCS - 7000

S/N - 2KW1-UP

S/N - 5SW1-UP

S/N - 6DZ1-UP

S/N - 6SW1-UP

S/N - 9FS1-UP

S/N - 9NW1-UP

S/N - 9WW1-UP

S/N - ADC1-UP

S/N - AEJ1-UP

---

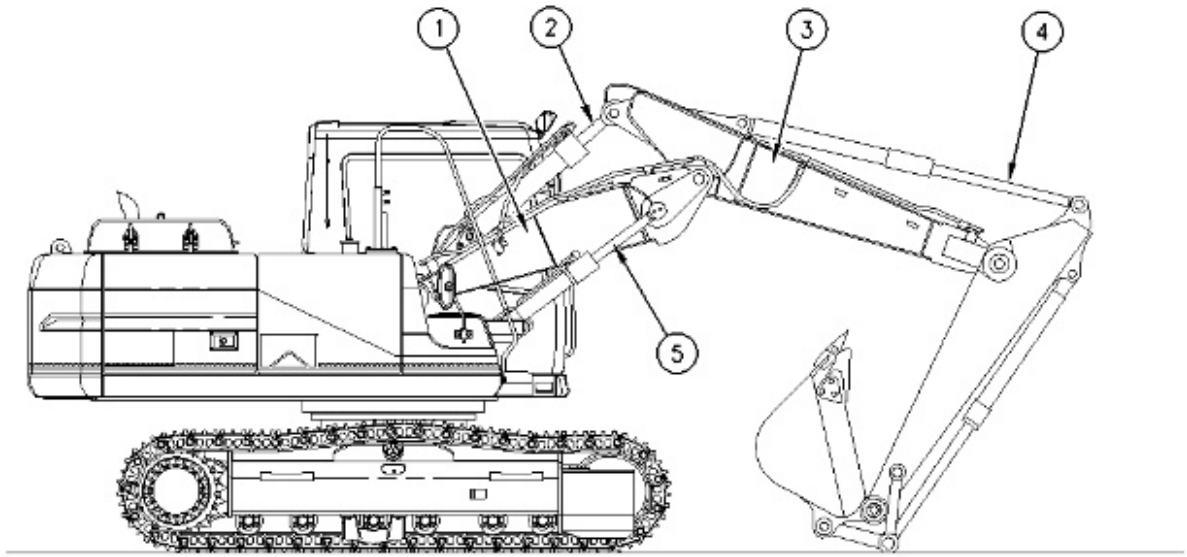

---

Illustration 1

g00776408

- (1) Stub boom
  - (2) Fore boom cylinder
  - (3) Fore boom
  - (4) Stick cylinder
  - (5) Stub boom cylinder
-

Product: EXCAVATOR

Model: 315B L EXCAVATOR 5SW

Configuration: 315B L Excavator 5SW00001-UP (MACHINE) POWERED BY 3054 Engine

## Operation and Maintenance Manual 307B, 312B, 315B, 317B and 318B Excavators

Media Number -SEBU7500-04

Publication Date -01/03/2001

Date Updated -16/11/2001

i01493628

### Working Ranges - VA Boom

SMCS - 7000

S/N - 5SW1-UP

Table 1

	Short Stick (1.85 m)	Medium Stick (2.25 m)	Long Stick (2.6 m)	Extra Long Stick (3.1 m)
Maximum digging depth	4.65 m	5.01 m	5.39 m	5.84 m
Maximum digging depth for a vertical wall	3.52 m	3.75 m	4.28 m	4.64 m
Maximum digging depth at a 2.44 m flat floor	4.51 m	4.88 m	5.27 m	5.73 m
Maximum reach at ground level	7.91 m	8.21 m	8.62 m	9.03 m
Maximum cutting height	9.38 m	9.62 m	9.99 m	10.32 m
Maximum loading height	7.11 m	7.25 m	7.72 m	7.97 m
Minimum loading height	3.76 m	3.5 mm	3.08 m	2.61 m

Product: EXCAVATOR

Model: 315B L EXCAVATOR 5SW

Configuration: 315B L Excavator 5SW00001-UP (MACHINE) POWERED BY 3054 Engine

## **Operation and Maintenance Manual 307B, 312B, 315B, 317B and 318B Excavators**

Media Number -SEBU7500-04

Publication Date -01/03/2001

Date Updated -16/11/2001

i01507529

### **VA Boom Controls**

SMCS - 5461-VAR

S/N - 2KW1-UP

S/N - 5SW1-UP

S/N - 6DZ1-UP

S/N - 6SW1-UP

S/N - 9FS1-UP

S/N - 9NW1-UP

S/N - 9WW1-UP

S/N - ADC1-UP

S/N - AEJ1-UP

---

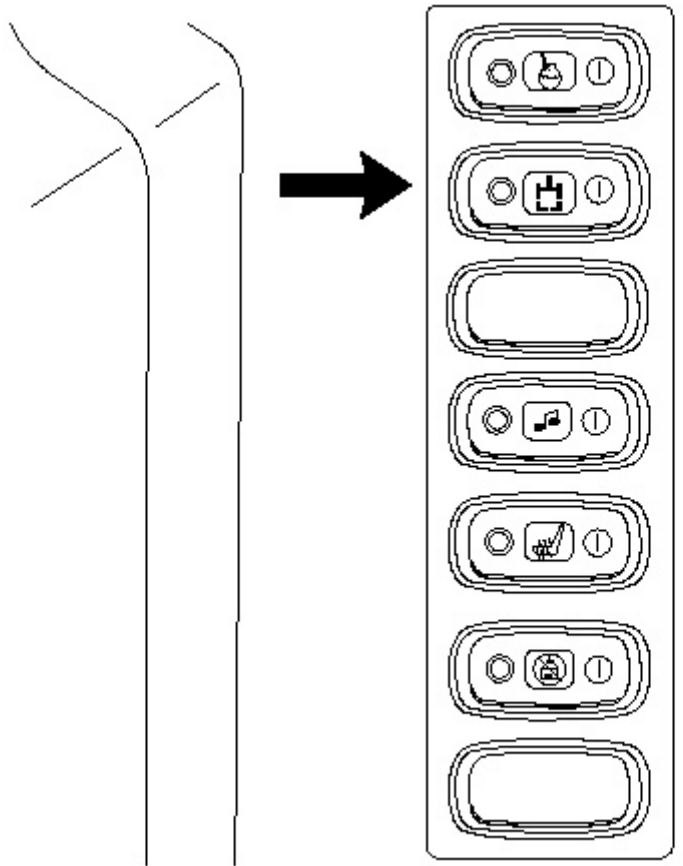
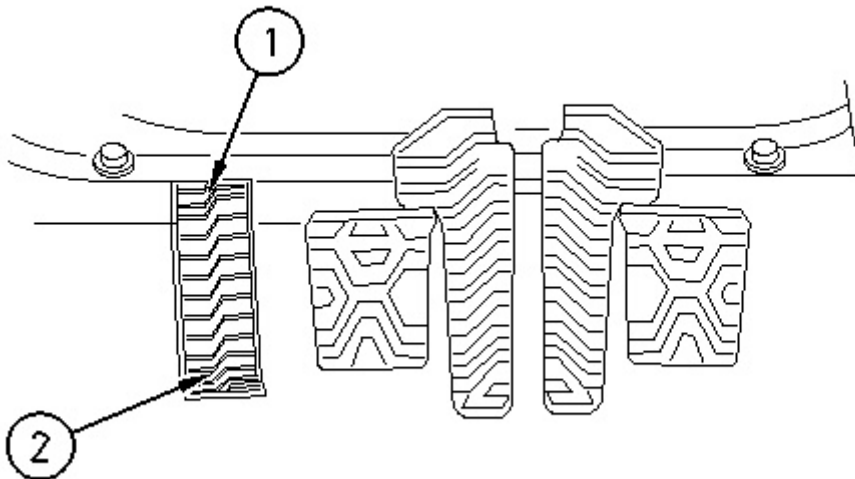

Illustration 1

g00775869

When a machine is equipped with auxiliary equipment, the pedal that operates the auxiliary equipment will also be the pedal that operates the VA boom. Since the auxiliary equipment and the VA boom are operated by the same pedal, a switch that is located on the right side console must be switched to the function that is desired.



The movement of the VA boom is proportional when the VA boom is operated with the pedal.

**VA Boom Open (1)** - Press downward on the front of the pedal in order to open the VA boom .

**VA Boom Close (2)** - Press downward on the rear of the pedal in order to close the VA boom.

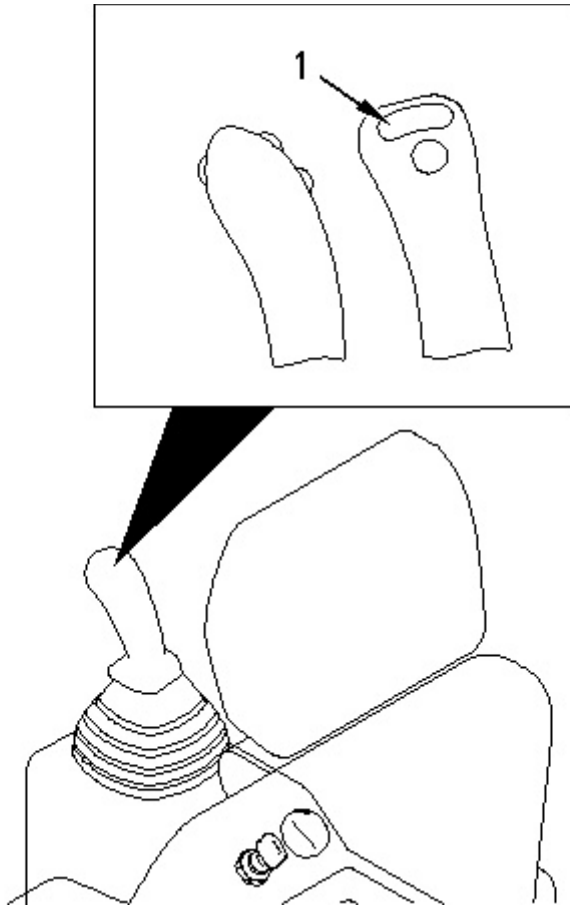

The VA boom can also be operated by using the top left button (1) on the right joystick. Boom movement is not proportional when the boom is operated with the joystick. Pressing the left button will open the VA boom.

Pressing the button corresponds to a full pedal stroke. The VA boom will stop moving when the button is released. This method of controlling the VA boom can be useful in loading trucks.

**Note:** The VA boom cannot be closed by using the button on the joystick.

---

Product: EXCAVATOR

Model: 315B L EXCAVATOR 5SW

Configuration: 315B L Excavator 5SW00001-UP (MACHINE) POWERED BY 3054 Engine

## **Operation and Maintenance Manual 307B, 312B, 315B, 317B and 318B Excavators**

Media Number -SEBU7500-04

Publication Date -01/03/2001

Date Updated -16/11/2001

i01496162

# **Hammer Operation**

SMCS - 5705-WTL

---

### **NOTICE**

**Selection of a hydraulic hammer must be done with extra care. Use of a hydraulic hammer not recommended by Caterpillar could result in structural damage to the machine. Consult your Caterpillar dealer for hydraulic hammer information.**

---

Only use the hydraulic hammer to break rocks, concrete, and other hard objects. Before you start hydraulic hammer operation, place the machine on a level, stable surface. If the machine must be placed on a slope or on a rough surface, be careful during operation.

Before you start hydraulic hammer operation, close the front window.

---

### **NOTICE**

**In order to avoid structural damage to the host machine or the hydraulic hammer, comply with the following:**

**Do not attempt to break rocks or concrete by burying the hammer tool completely into the rocks or concrete.**

**Do not apply a prying force to the hammer tool in order to remove the hammer tool from the material.**

---

Do not allow the hydraulic hammer to continuously operate at one location and for more than one minute. Change the location of the machine and repeat the procedure.

---

## NOTICE

**Failure to change the location of the machine could cause the hydraulic oil to overheat. Overheated hydraulic oil could cause damage to the accumulator or to the cylinder seals.**

---

Stop hydraulic hammer operation immediately if any of the hydraulic hoses are twisting rapidly. This indicates that the accumulator is punctured. Consult your Caterpillar dealer for the necessary repairs.

---

## NOTICE

**Do not use the dropping force of the hydraulic hammer to break rocks or other hard objects. This could cause structural damage to the machine.**

**Do not use the sides or back of the hydraulic hammer to move rocks or other hard objects. Doing this could cause damage not only to the hammer but to stick or boom cylinder.**

**Do not operate the hydraulic hammer with any of the cylinders fully retracted or extended. Doing this could cause structural damage to the machine, resulting in reduced machine life.**

---

Do not use the hydraulic hammer to lift an object.

Do not operate the hydraulic hammer while the stick is vertical to the ground. This could allow the stick cylinder to vibrate excessively.

Operate the attachment control levers carefully in order to keep the hydraulic hammer's chisel from hitting the boom.

Do not operate the hydraulic hammer with the upper structure sideways to the undercarriage. Before you start hydraulic hammer operation, place the upper structure in the recommended position that is shown in the following illustration. Any other operating positions could make the machine unstable. Any other operating positions could place excessive loads on the undercarriage.

---

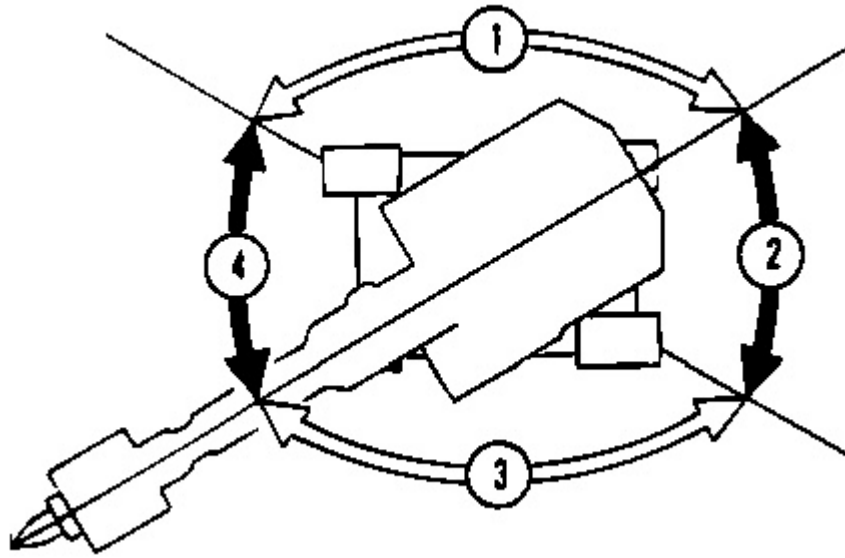

---

Illustration 1

g00105153

(1) Incorrect position. (2) Correct position. (3) Incorrect position. (4) Correct position.

---

Product: EXCAVATOR

Model: 315B L EXCAVATOR 5SW

Configuration: 315B L Excavator 5SW00001-UP (MACHINE) POWERED BY 3054 Engine

## **Operation and Maintenance Manual 307B, 312B, 315B, 317B and 318B Excavators**

Media Number -SEBU7500-04

Publication Date -01/03/2001

Date Updated -16/11/2001

i01494341

## **Shipping Specifications**

SMCS - 7000

S/N - 2KW1-UP

S/N - 5SW1-UP

S/N - 6DZ1-UP

S/N - 6SW1-UP

S/N - 9FS1-UP

S/N - 9NW1-UP

S/N - 9WW1-UP

S/N - ADC1-UP

S/N - AEJ1-UP

---

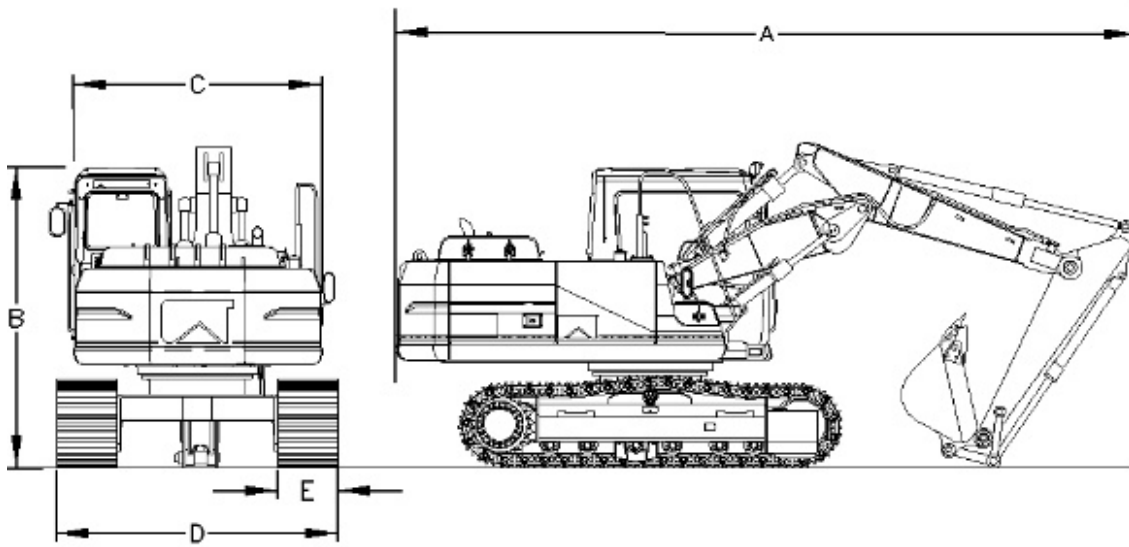

Illustration 1

g00778216

Table 1

<b>312B Excavator with VA Boom, 0.54 m<sup>3</sup> bucket, and 500 mm track shoes</b>	
Approximate Weight with Short Stick	13522 kg
Approximate Weight with Medium Stick	13592 kg
Approximate Weight with Long Stick	13670 kg
Overall Length with Short Stick (A)	7.73 m
Overall Length with Medium Stick (A)	7.62 m
Overall Length with Long Stick (A)	7.48 m
Height of Cab (B)	2.9 m
Overall Width (C)	2.55 m
Width of Track (D)	2.49 m
Track Shoe Width (E)	500 mm

Table 2

<b>312B L Excavator with VA Boom, 0.54 m<sup>3</sup> bucket, and 500 mm track shoes</b>	
Approximate Weight with Short Stick	13792 kg
Approximate Weight with Medium Stick	13862 kg
Approximate Weight with Long Stick	13940 kg
Overall Length with Short Stick (A)	7.73 m

Overall Length with Medium Stick (A)	7.62 m
Overall Length with Long Stick (A)	7.48 m
Height of Cab (B)	2.9 m
Overall Width (C)	2.55 m
Width of Track (D)	2.49 m
Track Shoe Width (E)	500 mm

Table 3

<b>315B L Excavator with VA Boom, 0.56 m<sup>3</sup> bucket, and 500 mm track shoes</b>	
Approximate Weight with Short Stick	17242 kg
Approximate Weight with Medium Stick	17312 kg
Approximate Weight with Long Stick	17382 kg
Approximate Weight with Extra Long Stick	17472 kg
Overall Length with Short Stick (A)	8.37 m
Overall Length with Medium Stick (A)	8.33 m
Overall Length with Long Stick (A)	8.34 m
Overall Length with Extra Long Stick (A)	8.31 m
Height of Cab (B)	3 m
Overall Width (C)	2.55 m
Width of Track (D)	2.49 m
Track Shoe Width (E)	500 mm

Table 4

<b>317B L Excavator with VA Boom, 0.56 m<sup>3</sup> bucket, and 600 mm track shoes</b>	
Approximate Weight with Short Stick	18459 kg
Approximate Weight with Medium Stick	18382 kg
Approximate Weight with Long Stick	18339 kg
Approximate Weight with Extra Long Stick	18372 kg
Overall Length with Short Stick (A)	8.64 m
Overall Length with Medium Stick (A)	8.37 m
Overall Length with Long Stick (A)	8.38 m
Overall Length with Extra Long Stick (A)	8.32 m
Height of Cab (B)	3.04 m



**Suggest:**

**For more complete manuals. Please go to the home page.**

**<https://www.ebooklibonline.com>**

**If the above button click is invalid. Please download this document first, and then click the above link to download the complete manual.**

**Thank you so much for reading**

Overall Width (C)	2.49 m
Width of Track (D)	2.8 m
Track Shoe Width (E)	600 mm

Table 5

<b>317B LN Excavator with VA Boom, 0.56 m<sup>3</sup> bucket, and 500 mm track shoes</b>	
Approximate Weight with Short Stick	18222 kg
Approximate Weight with Medium Stick	18132 kg
Approximate Weight with Long Stick	18102 kg
Approximate Weight with Extra Long Stick	18132 kg
Overall Length with Short Stick (A)	8.64 m
Overall Length with Medium Stick (A)	8.37 m
Overall Length with Long Stick (A)	8.38 m
Overall Length with Extra Long Stick (A)	8.32 m
Height of Cab (B)	3.04 m
Overall Width (C)	2.49 m
Width of Track (D)	2.495 m
Track Shoe Width (E)	500 mm

Table 6

<b>318B L Excavator with VA Boom, 1.05 m<sup>3</sup> bucket, and 600 mm track shoes</b>	
Approximate Weight with Short Stick	19560 kg
Approximate Weight with Medium Stick	19590 kg
Approximate Weight with Long Stick	19600 kg
Approximate Weight with Extra Long Stick	19650 kg
Overall Length with Short Stick (A)	8.65 m
Overall Length with Medium Stick (A)	8.55 m
Overall Length with Long Stick (A)	8.61 m
Overall Length with Extra Long Stick (A)	8.40 m
Height of Cab (B)	3.04 m
Overall Width (C)	2.49 m
Width of Track (D)	2.8 m
Track Shoe Width (E)	600 mm

Table 7

<b>318B LN Excavator with VA Boom, 1.05 m<sup>3</sup> bucket, and 500 mm track shoes</b>	
Approximate Weight with Short Stick	18860 kg
Approximate Weight with Medium Stick	18890 kg
Approximate Weight with Long Stick	18900 kg
Approximate Weight with Extra Long Stick	18950 kg
Overall Length with Short Stick (A)	8.65 m
Overall Length with Medium Stick (A)	8.55 m
Overall Length with Long Stick (A)	8.61 m
Overall Length with Extra Long Stick (A)	8.40 m
Height of Cab (B)	3.04 m
Overall Width (C)	2.49 m
Width of Track (D)	2.495 m
Track Shoe Width (E)	500 mm

Consult your Caterpillar dealer for specifications that are not included in tables 1 through 7.

---

**<https://www.ebooklibonline.com>**

Hello dear friend!

Thank you very much for reading.

Enter the link into your browser.

The full manual is available for immediate download.

**<https://www.ebooklibonline.com>**