

Product: SKID STEER LOADER

Model: 232 SKID STEER LOADER CAB

Configuration: 216 226 232 242 Skid Steer Loader CAB00001-UP (MACHINE) POWERED BY 3024C, 3034 Engine

## **Operation and Maintenance Manual Snow Push Work Tool Supplement**

Media Number -SEBU8787-02

Publication Date -01/10/2012

Date Updated -03/12/2012

s00272057

## **Foreword**

SMCS - 7606

## **Literature Information**

This manual should be stored in the operator's compartment in the literature holder or seat back literature storage area.

This manual contains safety information, operation instructions, transportation information, lubrication information and maintenance information.

Some photographs or illustrations in this publication show details that can be different from your work tool. Guards and covers might have been removed for illustrative purposes.

Continuing improvement and advancement of product design might have caused changes to your work tool which are not included in this publication. Read, study and keep this manual with the machine that your work tool is installed on.

Whenever a question arises regarding your work tool, or this publication, please consult your Caterpillar dealer for the latest available information.

## **Safety**

The safety section lists basic safety precautions. In addition, this section identifies the text and locations of safety signs and labels used on the work tool.

Read and understand the basic precautions listed in the safety section before operating or performing lubrication, maintenance and repair on this work tool.

## **Operation**

The operation section is a reference for the new operator and a refresher for the experienced operator. This section includes a discussion of gauges, switches, machine controls, work tool controls, transportation and towing information.

Photographs and illustrations guide the operator through correct procedures of checking, starting, operating and stopping the work tool.

Operating techniques outlined in this publication are basic. Skill and techniques develop as the operator gains knowledge of the work tool and its capabilities.

## **Maintenance**

The maintenance section is a guide to equipment care. The illustrated, step-by-step instructions are grouped by service intervals. Items without specific intervals are listed under the when required interval. Items in the maintenance intervals schedule are referenced to detailed instructions that follow.

### **Maintenance Intervals**

Calendar intervals shown (daily, weekly, monthly, etc) can be used instead of service hour meter intervals if they provide more convenient servicing schedules and approximate the indicated service hour meter reading. Recommended service should always be performed at the interval that occurs first.

Under extremely severe, dusty or wet operating conditions, more frequent lubrication than is specified in the maintenance intervals schedule might be necessary.

Perform service on items at multiples of the original requirement. For example, at every 500 service hours or 3 months, also service those items listed under every 250 service hours or monthly and every 10 service hours or daily.

---

Product: SKID STEER LOADER

Model: 232 SKID STEER LOADER CAB

Configuration: 216 226 232 242 Skid Steer Loader CAB00001-UP (MACHINE) POWERED BY 3024C, 3034 Engine

## Operation and Maintenance Manual Snow Push Work Tool Supplement

Media Number -SEBU8787-02

Publication Date -01/10/2012

Date Updated -03/12/2012

i04574540

### Plate Locations and Film Locations

SMCS - 1000; 3030; 4450; 6000; 6319; 6320; 6461; 6700; 7000; 7405; 7557

The product identification plate is located on the top rail of the back frame.

For quick reference, record the identification numbers in the spaces that are provided below the illustrations.

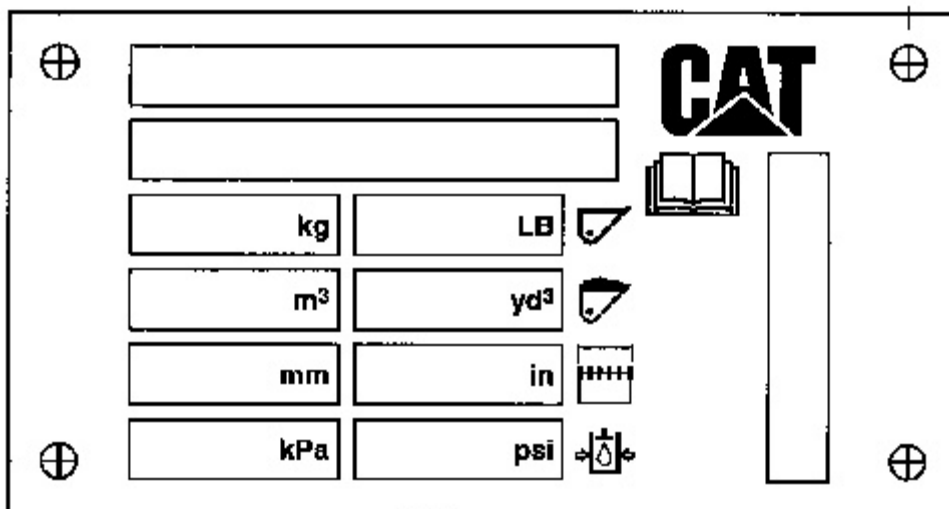

Illustration 1

g02733856

**<https://www.ebooklibonline.com>**

Hello dear friend!

Thank you very much for reading.

Enter the link into your browser.

The full manual is available for immediate download.

**<https://www.ebooklibonline.com>**

Product: SKID STEER LOADER

Model: 232 SKID STEER LOADER CAB

Configuration: 216 226 232 242 Skid Steer Loader CAB00001-UP (MACHINE) POWERED BY 3024C, 3034 Engine

## Operation and Maintenance Manual Snow Push Work Tool Supplement

Media Number -SEBU8787-02

Publication Date -01/10/2012

Date Updated -03/12/2012

i04571285

### Operating Technique Information

SMCS - 0375; 6282; 6319; 6320; 6346; 6700; 6710; 7000; 7615

### Settings

Do not use lift arm float or two speed modes while operating the snow push.

### Snow Push Positioning

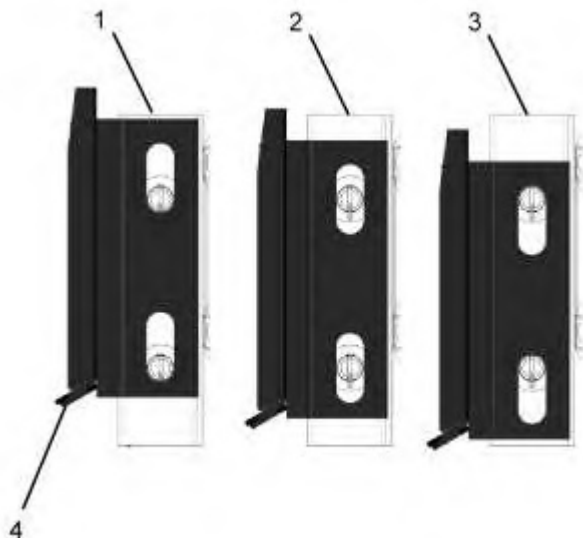

Illustration 1

g02733778

1. Place the coupler (4) and the frame in the vertical position using the machines tilt circuit. Tilt the snow push slightly forward for aggressive material removal.

2. Place the coupler slip hitch in the middle position (2) by raising and lowering the lift arms.

**Note:** There is also the top position (1) and the bottom position (3) .

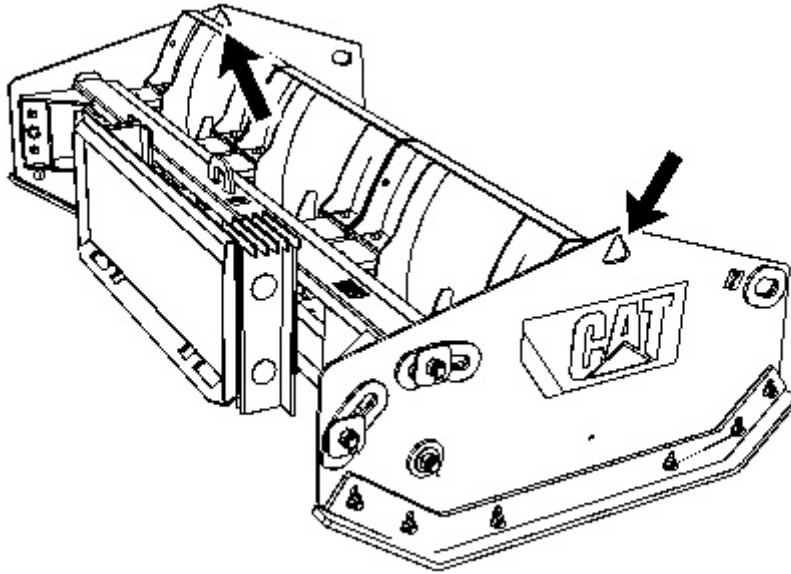

Illustration 2

g02734624

3. When lowering the snow push to the ground the moldboard should be behind the triangular holes in the side plate, which will block the view of the holes. If the frame is not vertical the triangular holes will be visible. Improper positioning will reduce mounting block life due to excess loading. Improper positioning will also reduce productivity as sections of the snow push will not float properly and the edges will not trip properly.

## Snow Handling

To stack snow on curbs, use the following procedure:

1. Slowly approach the curb.
2. Allow the side plates to rotate upward.
3. Slowly allow the cutting edges to contact the curb then slowly raise the lift arms and roll forward over the curb.

To stack snow into piles, use the following procedure:

1. Raise the boom as you continue forward.
2. Continue to raise the boom upward, pushing the snow upward and forward simultaneously.

**Note:** Never push snow into a frozen snow pile. This work tool is designed to scrape snow from the surface, this work tool is not to be used as a bucket. To push snow piles back or to relocate snow, use a bucket.

---

Product: SKID STEER LOADER

Model: 232 SKID STEER LOADER CAB

Configuration: 216 226 232 242 Skid Steer Loader CAB00001-UP (MACHINE) POWERED BY 3024C, 3034 Engine

## Operation and Maintenance Manual Snow Push Work Tool Supplement

Media Number -SEBU8787-02

Publication Date -01/10/2012

Date Updated -03/12/2012

i04571409

# Lifting and Tying Down the Machine

SMCS - 7000; 7500



**Lifting Point** - In order to lift the work tool, attach the lifting devices to the lifting points.

## Lifting The Snow Push

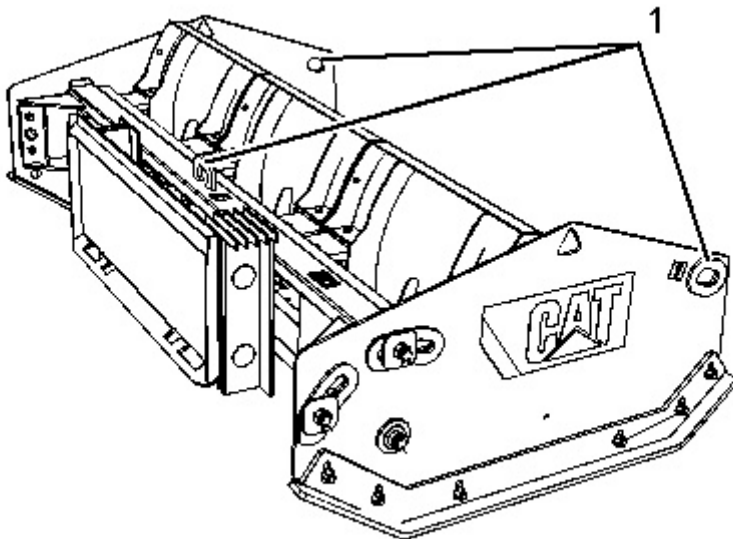

Illustration 1

g02731143

Use properly rated cables and properly rated slings for lifting work tools. Position the crane for a level lift. Do not drag the work tool with a crane.

Use hooks in the lifting eyes (1) at the center of the rear frame and on each side plate.

## **Tying Down the Snow Push**

Place chains or straps over the top of a section and the rear frame on both sides of the work tool.

---

Product: SKID STEER LOADER

Model: 232 SKID STEER LOADER CAB

Configuration: 216 226 232 242 Skid Steer Loader CAB00001-UP (MACHINE) POWERED BY 3024C, 3034 Engine

## Operation and Maintenance Manual Snow Push Work Tool Supplement

Media Number -SEBU8787-02

Publication Date -01/10/2012

Date Updated -03/12/2012

i04573612

### Side Plate - Replace

SMCS - 6700



**Personal injury or death can result from the blade falling.**

**Block the blade before changing blade tips.**

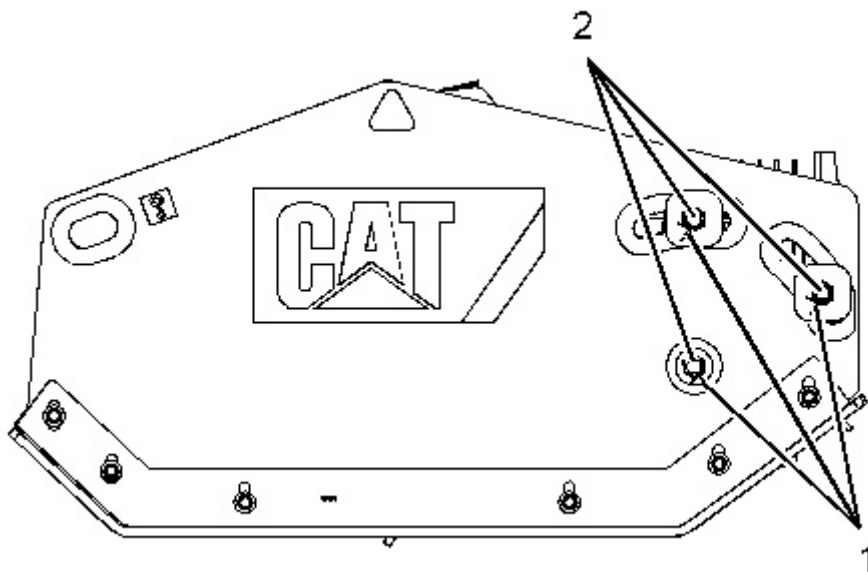

Illustration 1

g02731401

1. Raise lift arms to a height that will relieve pressure on the side panel wear shoes. Blocking should be placed under the frame and moldboard sections to prevent unexpected movement.
  2. Attach connection straps from the lift assisting device to the side plate to be removed.
  3. Remove cotter pins (1) .
  4. Remove nuts (2) .
  5. Using the lift assist, remove the side plate. Use caution when removing the plate as the plate may tip forward or backward.
  6. Coat the outer surfaces of the sleeve bushings with multipurpose grease.
  7. Attach connection straps of lift assisting device to the new side plate.
  8. Move the new plate into place ensuring that the mounting stud sleeve bushings are in place.
  9. Replace the nuts.
  10. Replace the cotter pins.
  11. Raise the lift arms and remove the blocking.
-

Product: SKID STEER LOADER

Model: 232 SKID STEER LOADER CAB

Configuration: 216 226 232 242 Skid Steer Loader CAB00001-UP (MACHINE) POWERED BY 3024C, 3034 Engine

## Operation and Maintenance Manual Snow Push Work Tool Supplement

Media Number -SEBU8787-02

Publication Date -01/10/2012

Date Updated -03/12/2012

i04573689

### Cutting Edges - Inspect/Replace

SMCS - 6320; 6801-510-G1; 6801-510; 6801-040-G1; 6801-040



**Personal injury or death can result from the blade falling.**

**Block the blade before changing blade tips.**

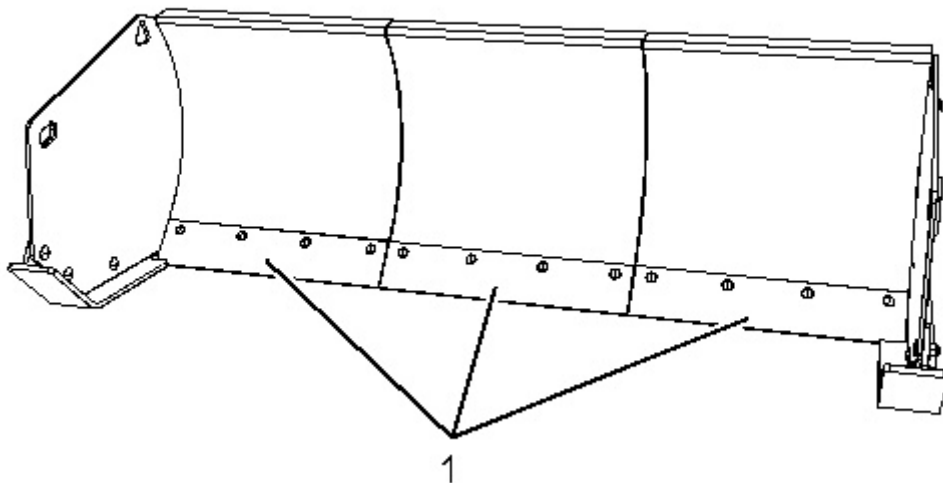

Illustration 1

g02731429

Cutting edges (1) may be damaged or worn excessively. Replace cutting edges, as needed.

1. Lower lift arms. Tilt the snow push backwards until the cutting edges are accessible.
  2. Place blocks under the cutting edge that is to be replaced to prevent unexpected movement. Blocking should be placed under the mounting angle and/or the mounting blocks. Tilt the snow push slightly forward to apply light pressure on the blocking.
  3. Remove the cutting edges.
  4. Install new cutting edges.
  5. Raise the snow push and remove the blocking.
-

Product: SKID STEER LOADER

Model: 232 SKID STEER LOADER CAB

Configuration: 216 226 232 242 Skid Steer Loader CAB00001-UP (MACHINE) POWERED BY 3024C, 3034 Engine

## Operation and Maintenance Manual Snow Push Work Tool Supplement

Media Number -SEBU8787-02

Publication Date -01/10/2012

Date Updated -03/12/2012

i04574068

### Side Plate Skid Plate - Inspect/Replace

SMCS - 6820



Personal injury or death can result from the blade falling.

Block the blade before changing blade tips.

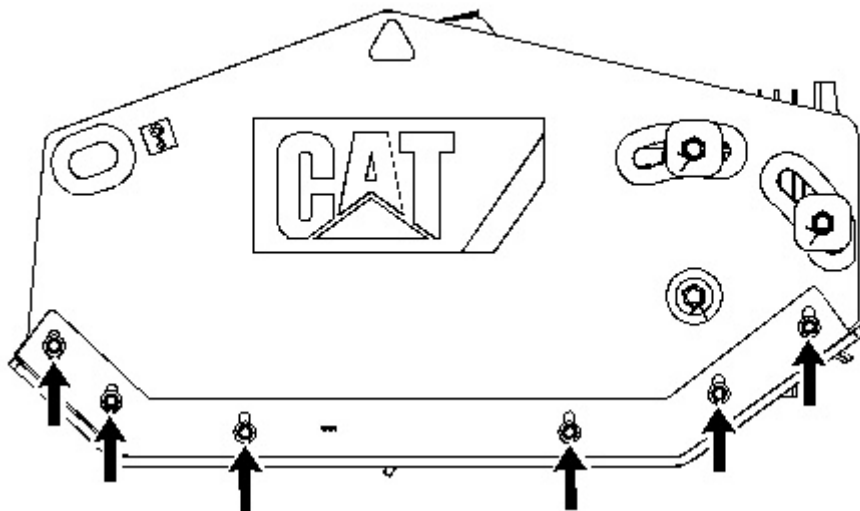

Illustration 1

g02731735

1. Raise lift arms to a height that will relieve pressure on the side panel skid plates. Blocking should be placed under the frame and moldboard sections to prevent unexpected movement.
  2. Remove nuts from skid plate.
  3. Remove skid plate.
  4. Install new skid plate.
  5. Raise the snow push and remove the blocking.
-

Product: SKID STEER LOADER

Model: 232 SKID STEER LOADER CAB

Configuration: 216 226 232 242 Skid Steer Loader CAB00001-UP (MACHINE) POWERED BY 3024C, 3034 Engine

## Operation and Maintenance Manual Snow Push Work Tool Supplement

Media Number -SEBU8787-02

Publication Date -01/10/2012

Date Updated -03/12/2012

i04574564

### Springs - Inspect/Replace

SMCS - 6262

#### Center Springs

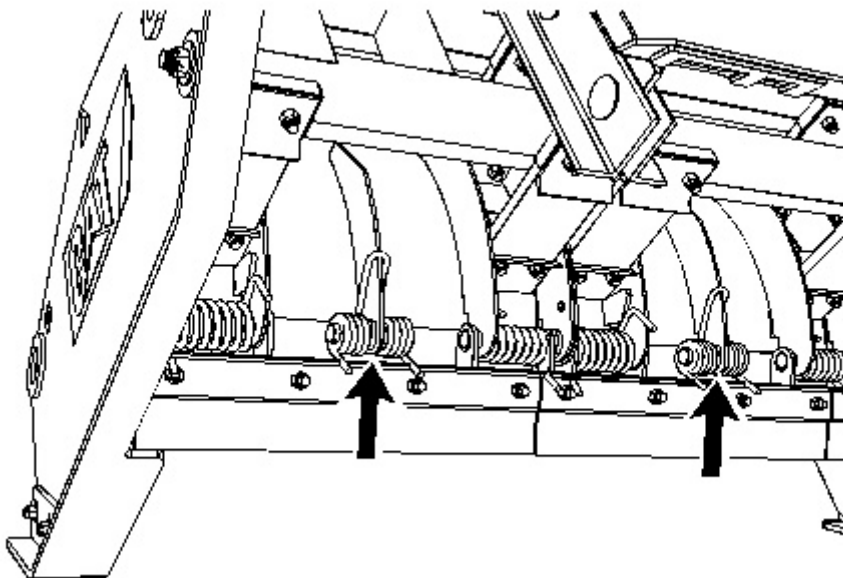

Illustration 1

g02733538

1. Raise lift arms and place blocking under side plate skid plates.
2. Remove the moldboard.
3. Remove the roll pin from the center spring pin and the right side spring.
4. Tap the right side spring pin until the spring is flush with the face.

5. Compress the spring to relieve pressure on the center pin. This is only necessary for unbroken pins. Contact your local Cat dealer for a center spring compression tool.
6. Remove center spring pin and remove spring and sleeve bushings. Inspect the pin for any damage.
7. Compress new center spring and reinstall the spring.
8. Reinstall spring sleeve bushings and center pin.
9. Relieve compression from the center spring.
10. Install the new roll pin in the center spring.
11. Reinstall the right side pin and install new roll pin.
12. Reinstall moldboard.

## Outer Springs

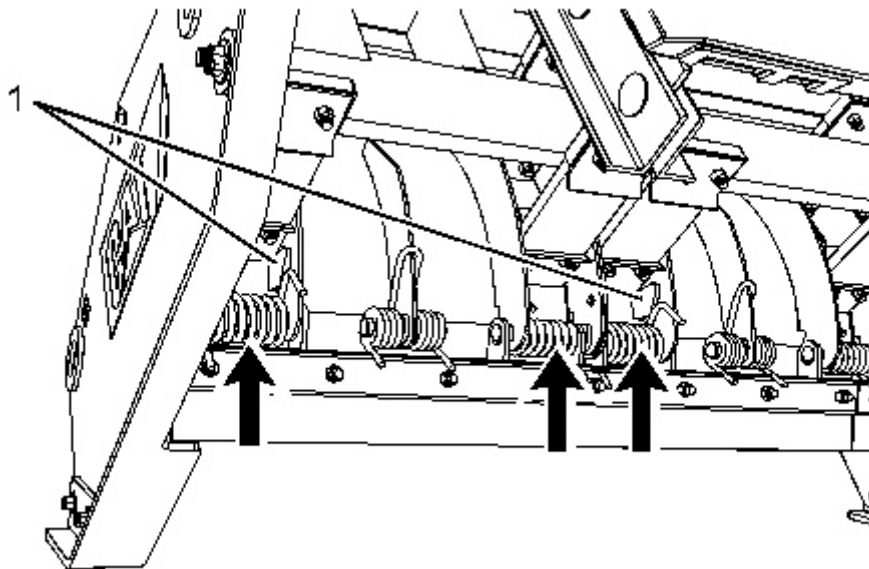

---

Illustration 2

g02733540

1. Raise lift arms and place blocking under side plate skid plates.
2. Remove the moldboard.
3. Remove the roll pin from the center spring pin and the right side pin.
4. Tap the right side spring pin until the spring is flush with the face.
5. Compress the spring to relieve pressure on the center pin. Compressing the spring is only necessary for unbroken pins. Contact your local Cat dealer for a center spring compression tool.

6. Remove center spring pin and remove spring and sleeve bushings. Inspect the pin for any damage.
  7. Relieve pressure on outer springs by forcing the upper spring leg inside the spring tensioning block (1). Relieve the pressure on both springs.
  8. Remove outer spring pins and remove spring and sleeve bushings. Inspect the pin for any damage.
  9. Insert sleeve bushings into new spring and position between the ribs.
  10. Insert the outer spring.
  11. Compress new center spring and reinstall the spring.
  12. Reinstall spring sleeve bushings and center pin.
  13. Relieve compression from the center spring.
  14. Install the new roll pin in the center spring.
  15. Install outer spring pin and insert new roll pin.
  16. Force the upper leg of the outer spring back under the spring tensioning block (1). Repeat this for the other outer spring.
  17. Reinstall moldboard.
-

Product: SKID STEER LOADER

Model: 232 SKID STEER LOADER CAB

Configuration: 216 226 232 242 Skid Steer Loader CAB00001-UP (MACHINE) POWERED BY 3024C, 3034 Engine

## **Operation and Maintenance Manual Snow Push Work Tool Supplement**

Media Number -SEBU8787-02

Publication Date -01/10/2012

Date Updated -03/12/2012

i04574115

### **Mounting Plates - Inspect/Replace**

SMCS - 1221



**Personal injury or death can result from the blade falling.**

**Block the blade before changing blade tips.**

---

---



**Suggest:**

**For more complete manuals. Please go to the home page.**

**<https://www.ebooklibonline.com>**

**If the above button click is invalid. Please download this document first, and then click the above link to download the complete manual.**

**Thank you so much for reading**

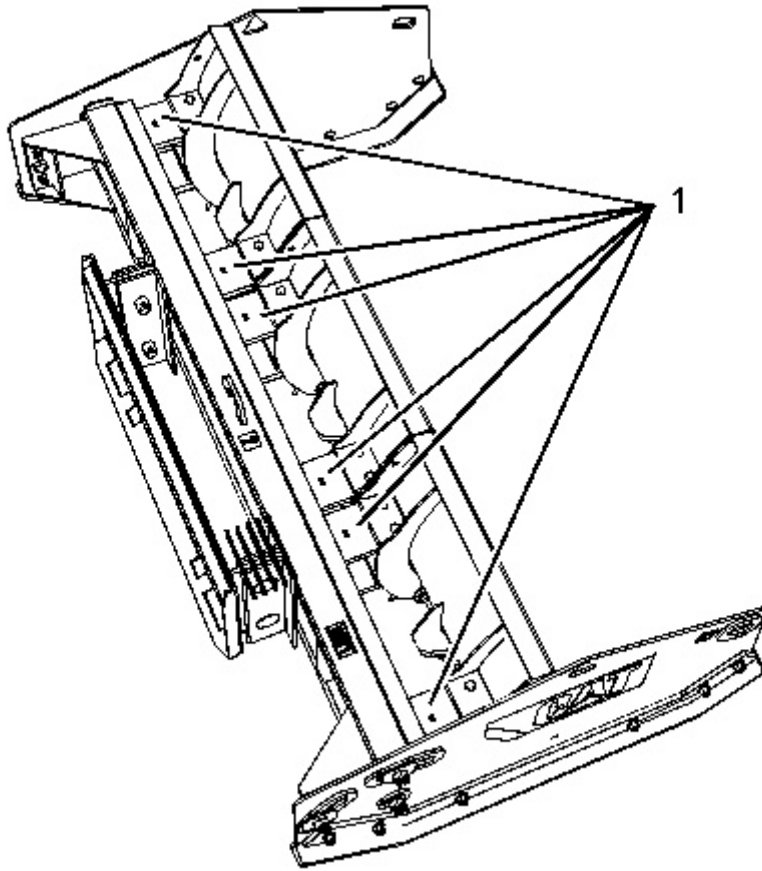

---

Illustration 1

g02731782

The mounting plates (1) may be damaged or cracked. Replace mounting plates (1) as needed.

1. Raise lift arms and place blocking under side plate skid plates until upward pressure on the moldboard is relieved.
  2. Remove bolts.
  3. Remove mounting plate (1) .
  4. Install new mounting plate.
  5. Replace bolts.
  6. Raise lift arms and remove the blocking.
-



**<https://www.ebooklibonline.com>**

Hello dear friend!

Thank you very much for reading.

Enter the link into your browser.

The full manual is available for immediate download.

**<https://www.ebooklibonline.com>**