

Product: EXCAVATOR

Model: 215D EXCAVATOR 9TF

Configuration: 215D EXCAVATOR 9TF00001-UP (MACHINE) POWERED BY 3304 ENGINE

Operation and Maintenance Manual 215D AND 219D TRACK-TYPE EXCAVATORS

Media Number -SEBU6317-01

Publication Date -01/02/1990

Date Updated -11/10/2001

Foreword

SMCS - 7606

This manual contains safety, operation, transportation, lubrication and maintenance information.

Some photographs or illustrations in this publication show details or attachments that may be different from your machine. Guards and covers may have been removed for illustrative purposes.

Continuing improvement and advancement of product design may have caused changes to your machine which are not included in this publication.

Read-study-and keep the "Operation and Maintenance Manual" with the machine.

Whenever a question arises regarding your machine, or this publication, please consult your Caterpillar dealer for the latest available information.

Safety

The safety section lists basic safety precautions. In addition, this section identifies the text and locations of warning labels used on the machine.

Read and understand the basic precautions listed in the safety section before operating or performing lubrication, maintenance and repair on this product.

Operation

The operation section is a reference for the new operator and a refresher for the experienced one. This section includes a discussion of gauges, switches, machine controls, implement controls, transportation and towing information.

Photographs and illustrations guide the operator through correct procedures of checking, starting, operating and stopping the machine.

Operating techniques outlined in this publication are basic. Skill and techniques develop as the operator gains knowledge of the machine and its capabilities.

Maintenance

The maintenance section is a guide to equipment care. The illustrated, step-by-step instructions are grouped by servicing intervals. Items without specific intervals are listed under "When Required" topics. Items in the "Maintenance Intervals" chart are referenced to detailed instructions that follow.

Maintenance Intervals

Use the service hour meter to determine servicing intervals. Calendar intervals shown (daily, weekly, monthly, etc.) may be used instead of service hour meter intervals if they provide more convenient servicing schedules and approximate the indicated service hour meter reading. Recommended service should always be performed at the interval that occurs first.

Under extremely severe, dusty or wet operating conditions, more frequent lubrication than is specified in the "Maintenance Interval" chart may be necessary.

Perform service on items at multiples of the original requirement. For example, at "Every 500 Service Hours or 3 Months", also service those items listed under "Every 250 Service Hours or Monthly", "Every 50 Service Hours or Weekly" and "Every 10 Service Hours or Daily".

Machine Description

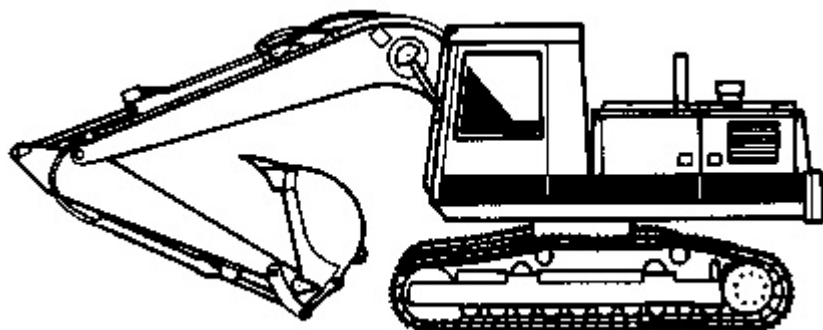

This machine is equipped with a four cylinder, direct injection diesel 3304 turbocharged engine. It has hydrostatic drive, variable flow hydraulics and spring applied/hydraulically released brakes. The machine is designed primarily for excavating and moving material.

Machine Storage

For complete machine storage information refer to Special Instruction SEHS9031, "Storage Procedure for Caterpillar Products".

Product: EXCAVATOR

Model: 215D EXCAVATOR 9TF

Configuration: 215D EXCAVATOR 9TF00001-UP (MACHINE) POWERED BY 3304 ENGINE

Operation and Maintenance Manual 215D AND 219D TRACK-TYPE EXCAVATORS

Media Number -SEBU6317-01

Publication Date -01/02/1990

Date Updated -11/10/2001

Safety

SMCS - 7606

Warning Signs and Labels

There are several specific safety signs on your machine. Their exact location and description of the hazard are reviewed in this section. Please take the time to familiarize yourself with these safety signs.

Make sure that you can read all safety signs. Clean or replace these if you cannot read the words or see the pictures. When cleaning the labels use a cloth, water and soap. Do not use solvent, gasoline, etc.

You must replace a label if it is damaged, missing or cannot be read. If a label is on a part that is replaced, make sure a new label is installed on the replaced part. See your Caterpillar dealer for new labels.



Do not operate or work on this machine unless you have read and understand the instructions and warnings in the Operation and Maintenance guide. Failure to follow the instructions or heed the warnings could result in injury or death. Contact any Caterpillar dealer for replacement guides. Proper care is your responsibility.

<https://www.ebooklibonline.com>

Hello dear friend!

Thank you very much for reading.

Enter the link into your browser.

The full manual is available for immediate download.

<https://www.ebooklibonline.com>

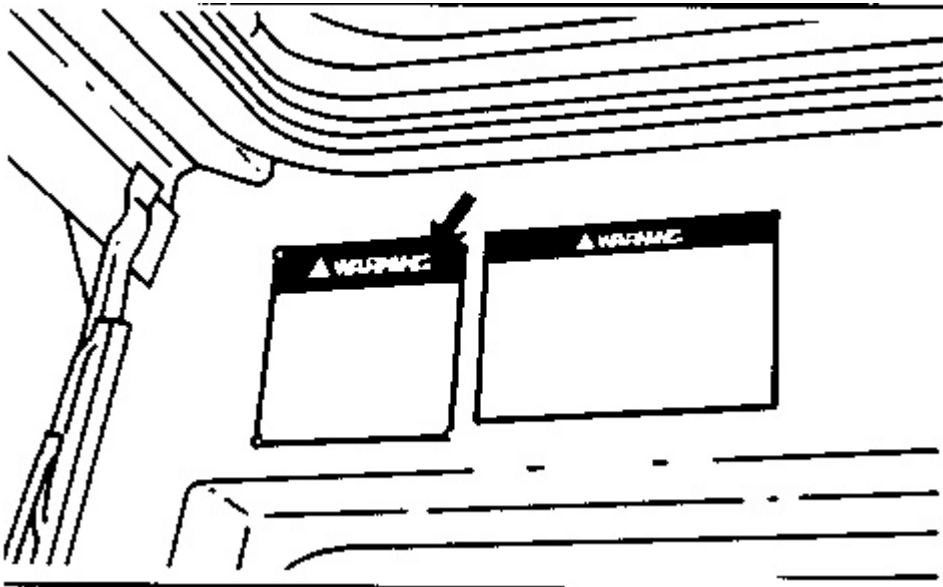

Located in the cab.

 **WARNING**

Always block both tracks when final drive is disconnected. With final drive disconnected machine has no brakes and will roll free on a slope or while towing.

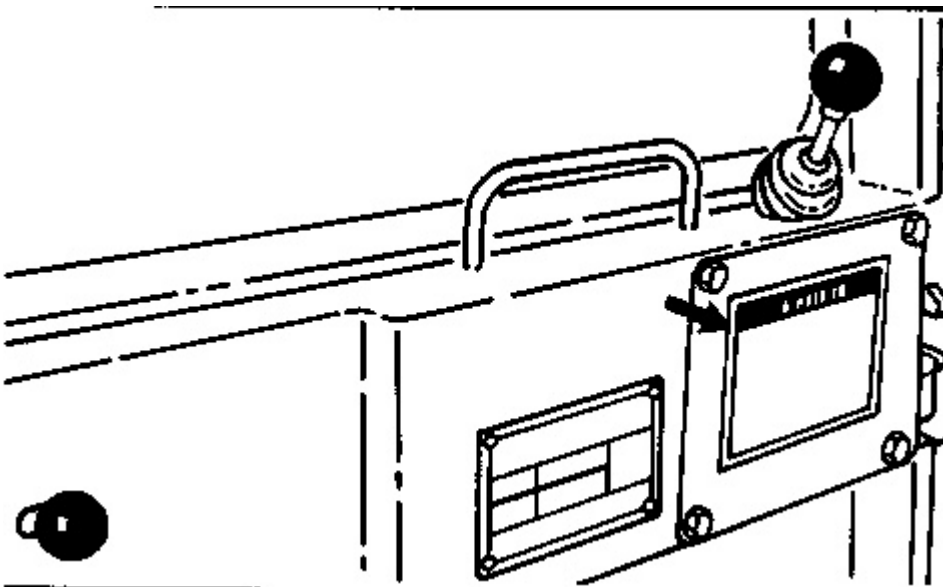

Located on the cab door.

 **WARNING**

Do not lift machine by counterweight eyes. Lift eyes can fail under this load causing possible personal injury. See Operation guide for proper method of lifting machine.

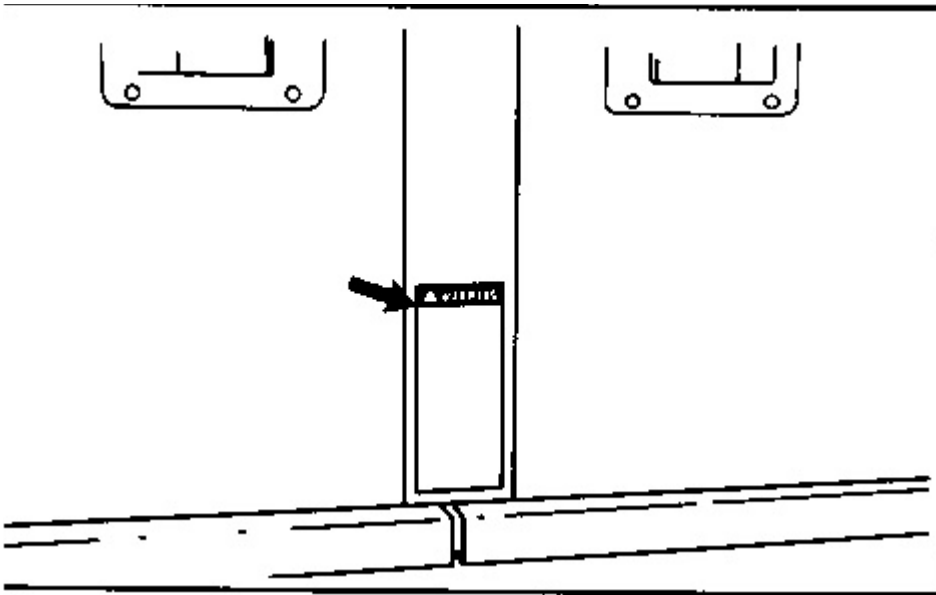

Located above the counterweight.

! WARNING

HIGH PRESSURE CYLINDER - Do not remove any parts until all pressure has been relieved to avoid possible personal injury. Relieve pressure by opening relief valve 1 turn maximum. See the "Operation & Maintenance" Guide for track adjustment procedure.

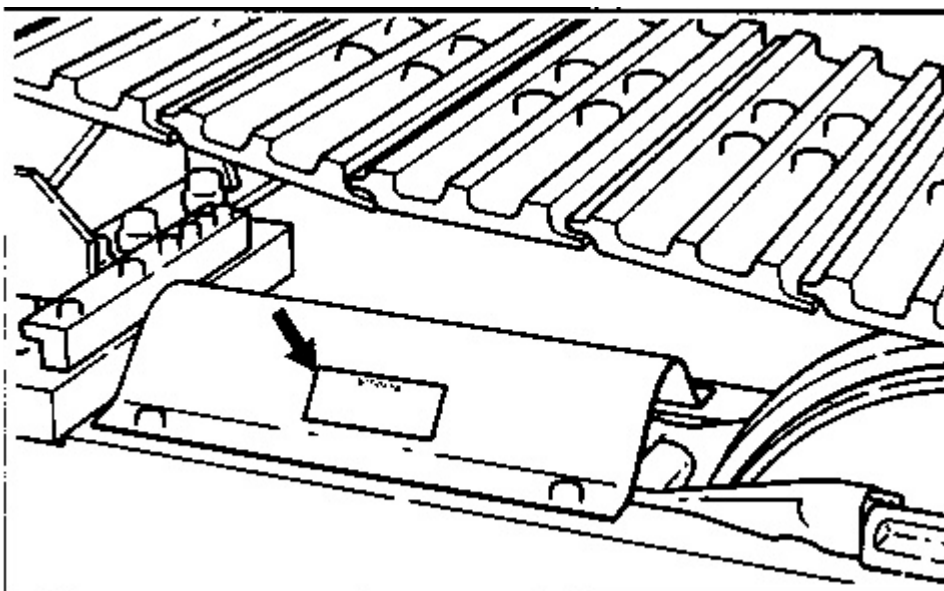

Located on both track roller frames.

 **WARNING**

Swing lock must be engaged before shipping machine. If lock is not engaged, upper structure can swing, resulting in possible personal injury.

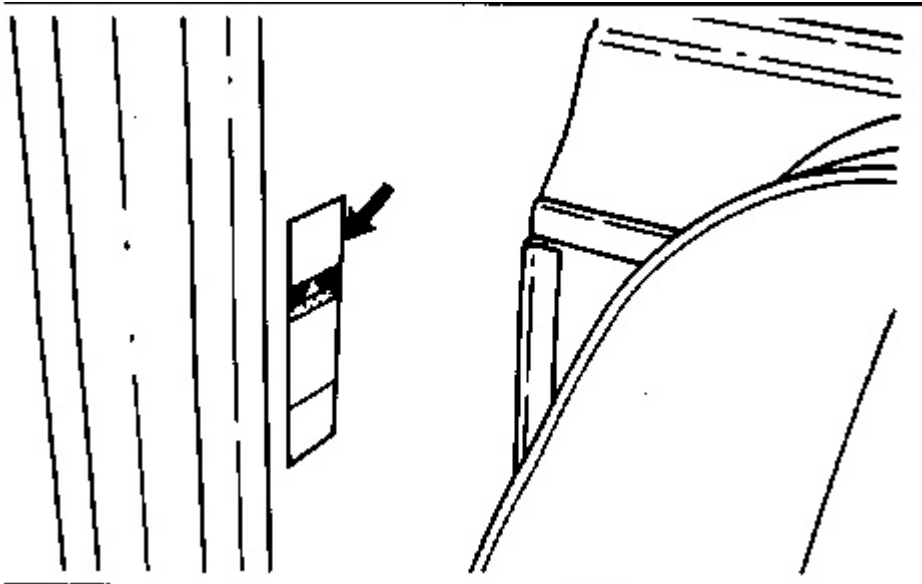

Located in the cab.

 **WARNING**

Know the maximum height and reach of your machine. Serious injury or death by electrocution can occur if machine or attachments are not kept a safe distance from electrical power lines. Keep distance at least 3 m (10 feet) plus additional 10 mm (0.4 inch) for each 1,000 volts over 50,000 volts.

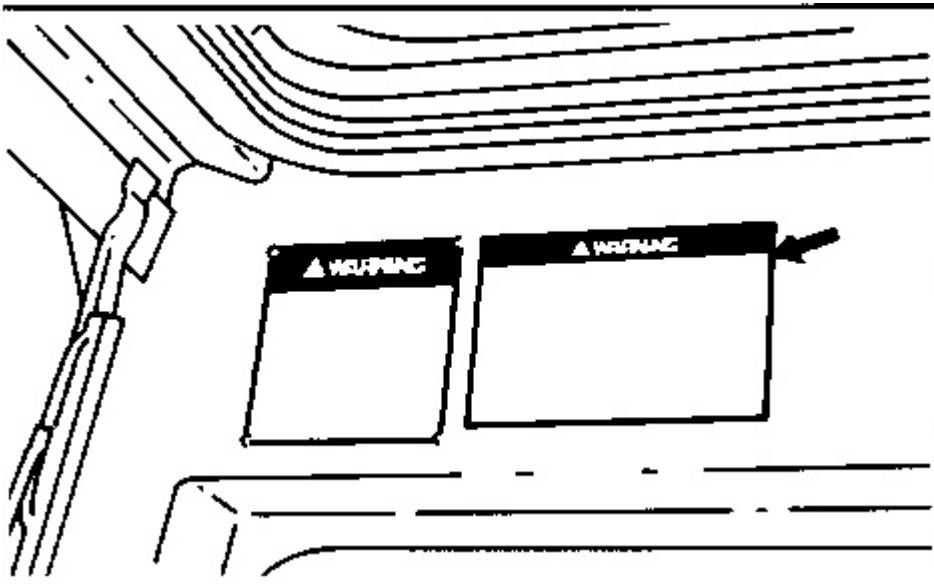

Located in the cab.

 **WARNING**

Improper jumper cable connections can cause an explosion resulting in personal injury. Batteries in series may be located in separate compartments. When using jumper cables always connect positive (+) cable to positive (+) terminal of battery connected to starter solenoid and negative (-) cable from external source to starter negative (-) terminal. (If not equipped with starter negative terminal, connect to engine block.)

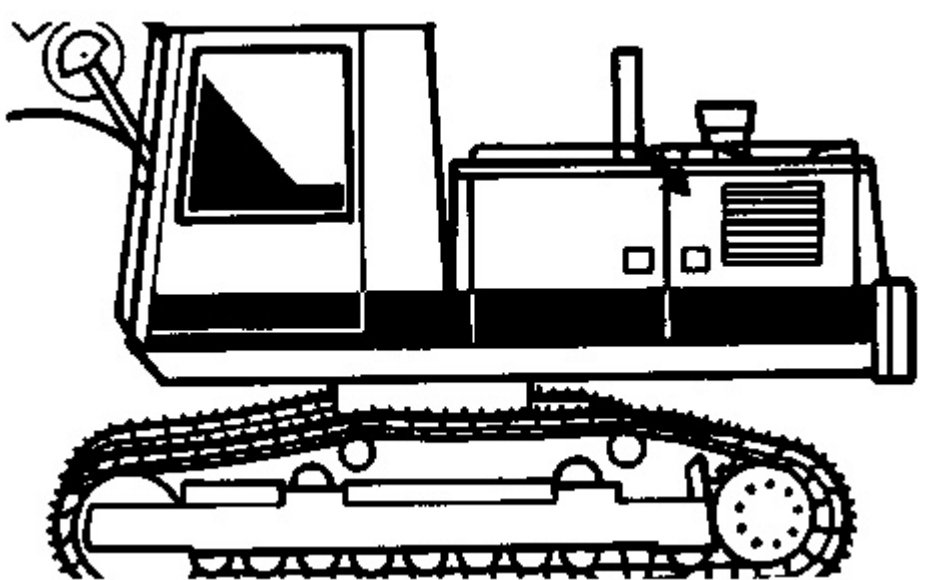

Located in the battery compartment.

General Hazard Information

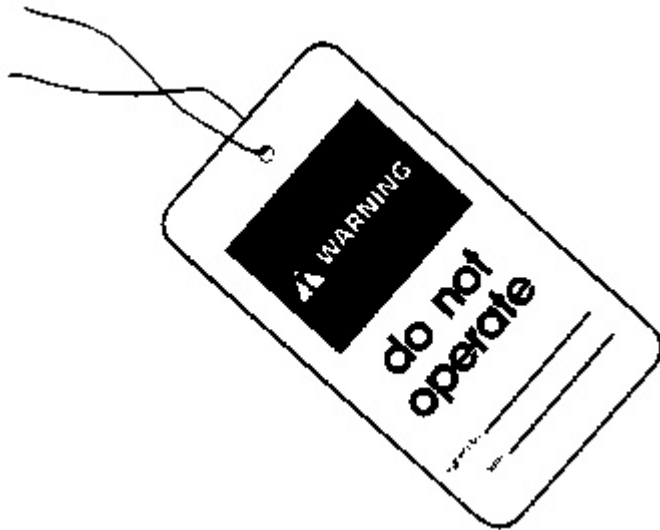

Attach a "DO NOT OPERATE" or similar warning tag to start switch or controls before servicing or repairing the machine. These tags, Form SEHS7332, are available from your Caterpillar dealer.

Perform all maintenance unless otherwise specified as follows:

- * Park the machine on level ground.
- * The swing lock pin engaged.
- * The travel pedals released.
- * The hydraulic and directional lock lever engaged.
- * The engine stopped.
- * The start switch key off and the key removed.
- * The disconnect switch off and the key removed.

Wear a hard hat, protective glasses and other protective equipment as required by job conditions.

Do not wear loose clothing or jewelry that can catch on controls or other parts of the machine.

Make certain all protective guards and covers are secured in place on the machine.

Keep the machine, especially the deck, walkways and steps, free of foreign material, such as debris, oil, tools and other items which are not part of the machine.

Secure all loose items such as lunch boxes, tools and other items which are not part of the machine.

Know the hand signals and who gives them. Accept signals from one person only.

Never put maintenance fluids into glass containers.

Report all needed repairs.

Do not allow unauthorized personnel on the machine.

Pressure Air

Pressure air can cause personal injury. When using pressure air for cleaning, wear a protective face shield and protective clothing.

The maximum air pressure must be below 205 kPa (30 psi) for cleaning purposes.

Fluid Penetration

Always use a board or cardboard when checking for a leak. Escaping fluid under pressure, even a pin-hole size leak, can penetrate body tissue, causing serious injury, and possible death. If fluid is injected into your skin, it must be treated by a doctor familiar with this type of injury immediately.

Track adjusting grease and oil is under high pressure. Grease or oil coming out of the relief valve under pressure can penetrate the body causing injury or death.

Do not watch the relief valve to see if grease is escaping. Watch the track or track adjustment cylinder to see if the track is being loosened. Loosen the relief valve one turn only.

Asbestos Information

Caution should be used to avoid breathing dust that may be generated when handling components containing asbestos fibers. If this dust is inhaled, it can be hazardous to your health. Components in Caterpillar products that may contain asbestos fibers are brake pads, brake band and lining assemblies, clutch plates and some gaskets. The asbestos used in these components is usually bound in a resin or sealed in some way. Normal handling is not hazardous as long as airborne dust which contains asbestos is not generated.

If dust which may contain asbestos is present, there are several common sense guidelines that should be followed.

- * Never use compressed air for cleaning.
- * Avoid brushing or grinding of asbestos containing materials.
- * For clean up, use wet methods or a vacuum equipped with a high efficiency particulate air (HEPA) filter.
- * Use exhaust ventilation on permanent machining jobs.
- * Wear an approved respirator if there is no other way to control the dust.
- * Comply with applicable rules and regulations for the work place (for example in the U.S.A., OSHA requirements as set forth in 29 CFR 1910.1001).
- * Follow environmental rules and regulations for disposal of asbestos.
- * Avoid areas where asbestos particles may be in the air.

Crushing or Cutting Prevention

Never attempt adjustments while the machine is moving or the engine is running unless otherwise specified.

Support equipment and implements properly when working beneath them. Do not depend on hydraulic cylinders to hold it up. Any implement can fall if a control is moved, or if a hydraulic line breaks.

Where there are implement linkages, the clearance in the linkage area will increase or decrease with movement of the implement.

Stay clear of all rotating and moving parts.

Keep objects away from moving fan blades. They will throw or cut any object or tool that falls or is pushed into them.

Do not use a kinked or frayed wire rope cable. Wear gloves when handling the wire rope cable.

Retainer pins, when struck with force, can fly out and injure nearby persons.

Wear protective glasses when striking a retainer pin to avoid injury to your eyes.

Chips or other debris can fly off objects when struck. Make sure no one can be injured by flying debris before striking any object.

Burn Prevention

Coolant

At operating temperature, the engine coolant is hot and under pressure. The radiator and all lines to heaters or the engine contain hot water or steam. Any contact can cause severe burns.

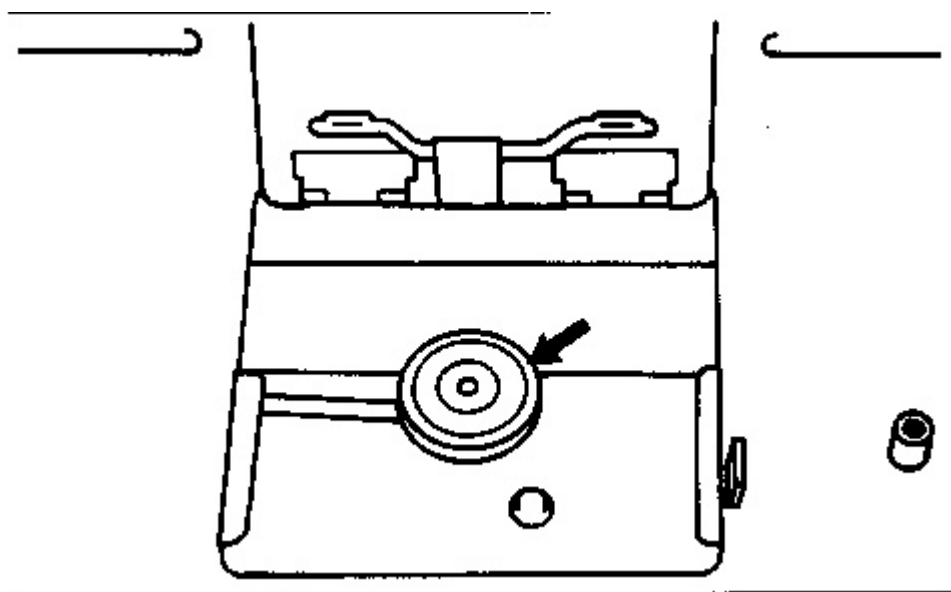

Check the coolant level only after the engine has been stopped and the filler cap is cool enough to remove with your bare hand.

Remove the cooling system filler cap slowly to relieve pressure.

Cooling system conditioner contains alkali that can cause personal injury. Avoid contact with the skin and eyes and do not drink.

Allow cooling system components to cool before draining.

Oils

Hot oil and components can cause personal injury. Do not allow hot oil or components to contact the skin.

At operating temperature, the hydraulic tank is hot and can be under pressure.

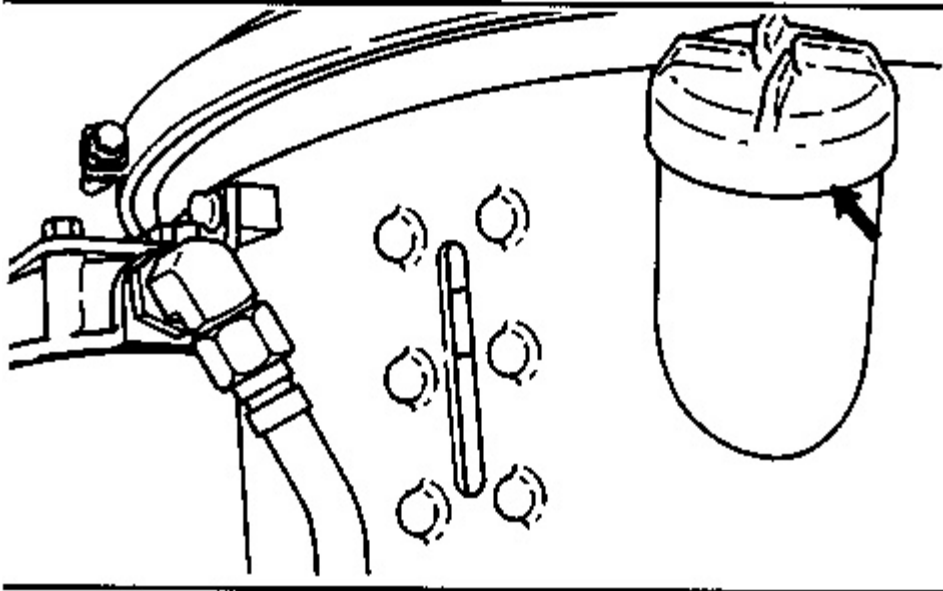

Remove the hydraulic tank filler cap only after the engine has been stopped and the filler cap is cool enough to remove with your bare hand.

Remove the hydraulic tank filler cap slowly to relieve pressure.

Relieve all pressure in air, oil, fuel or cooling systems before any lines, fittings or related items are disconnected or removed.

Batteries

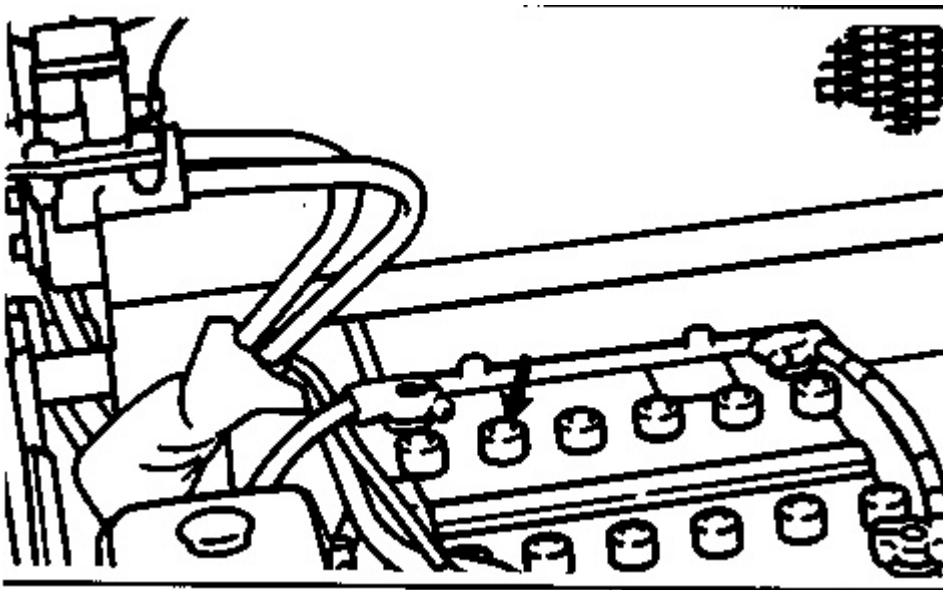

Batteries give off flammable fumes which can explode.

Do not smoke when observing the battery electrolyte levels.

Electrolyte is an acid and can cause personal injury if it contacts skin or eyes.

Always wear protective glasses when working with batteries.

Fire or Explosion Prevention

All fuels, most lubricants and some coolant mixtures are flammable.

Do not smoke while refueling or in a refueling area.

Do not smoke in areas where batteries are charged, or where flammable materials are stored.

Batteries in series may be located in separate compartments. When using jumper cables always connect positive (+) cable to positive (+) terminal of battery connected to starter solenoid and negative (-) cable from external source to starter negative (-) terminal. (If not equipped with starter negative terminal, connect to engine block.)

See the "Operation Section" of this manual for specific instructions.

Clean and tighten all electrical connections. Check daily for loose or frayed electrical wires. Have all loose or frayed electrical wires tightened, repaired or replaced before operating the machine.

Keep all fuels and lubricants stored in properly marked containers and away from all unauthorized persons.

Store all oily rags or other flammable material in a protective container, in a safe place.

Do not weld or flame cut on pipes or tubes that contain flammable fluids. Clean them thoroughly with nonflammable solvent before welding or flame cutting on them.

Remove all flammable materials such as fuel, oil and other debris before they accumulate on the machine.

Do not expose the machine to flames, burning brush, etc., if at all possible.

Shields, which protect hot exhaust components from oil or fuel spray in the event of a line, tube or seal failure, must be installed correctly.

Ether

Ether is poisonous and flammable.

Breathing ether vapors or repeated contact of ether with skin can cause personal injury.

Use ether only in well ventilated areas.

Do not smoke while changing ether cylinders.

Use ether with care to avoid fires.

Do not store replacement ether cylinders in living areas or in the operator's compartment.

Do not store ether cylinders in direct sunlight or at temperatures above 39°C (102°F).

Discard cylinders in a safe place. Do not puncture or burn cylinders.

Keep ether cylinders out of the reach of unauthorized personnel.

Lines, Tubes and Hoses

Do not bend or strike high pressure lines. Do not install bent or damaged lines, tubes or hoses.

Repair any loose or damaged fuel and oil lines, tubes and hoses. Leaks can cause fires.

Inspect all lines, tubes and hoses carefully. Do not use your bare hand to check for leaks. Tighten all connections to the recommended torque.

- * End fittings damaged or leaking.
- * Outer covering chafed or cut and wire reinforcing exposed.
- * Outer covering ballooning locally.
- * Evidence of kinking or crushing of the flexible part of hose.
- * Armouring embedded in the outer cover.
- * End fittings displaced.

Make sure that all clamps, guards and heat shields are installed correctly to prevent vibration, rubbing against other parts, and excessive heat during operation.

Mounting and Dismounting

Mount and dismount the machine only where steps and/or handholds are provided.

Use both hands and face the machine, when mounting and dismounting.

Never get on or off a moving machine. Never jump off the machine.

Do not try to climb on or off the machine when carrying tools or supplies. Use a hand line to pull equipment up onto the platform.

Secondary Exit

Machines equipped with cabs are equipped with secondary exits. For additional secondary exit information refer to the topic "Windshield" in the "Monitoring Systems and Cab Features" section of this manual.

Before Starting the Engine

Inspect the condition of the seat belt and mounting hardware. Replace any damaged or worn parts. Replace the seat belt regardless of appearance, after three years of use.

Adjust the seat so that full pedal travel can be obtained with the operator's back against the seat back.

Make sure the machine is equipped with a lighting system as required by conditions.

Make sure all lights are working properly.

Make sure no one is working on, underneath or close to the machine before starting the engine or beginning to move the machine. Make sure the area is free of personnel.

Start the engine only from the operator's station. Never short across the starter terminals or across the batteries, as this could bypass the engine neutral-start system as well as damage the electrical system.

Engine Starting

Do not start the engine or move any of the controls if there is a "DO NOT OPERATE" or similar warning tag attached to the start switch or controls.

Move all implement controls to the HOLD position before starting the engine.

Engage the hydraulic and directional lock lever.

Engage the swing brake control.

Start and operate the engine in a well ventilated area only. In an enclosed area, vent the exhaust to the outside.

Before Operating the Machine

Clear all personnel from the machine and the area.

Clear all obstacles from the path of the machine. Beware of hazards such as wires, ditches, etc.

Be sure all windows are clean. Secure the doors and windows in either the open or shut position.

For best vision, especially close to the machine, adjust the rear view mirrors.

Make sure the machine horn and all other warning devices are working properly.

Fasten the seat belt securely.

Check for proper operation of all controls and protective devices while moving slowly in an open area.

Machine Operation

Operate the machine only while seated.

Operate the controls only with the engine running.

The operator must satisfy himself that no one will be endangered before moving the machine.

Do not allow riders on the machine unless additional seat and seat belt are provided.

Report any needed repairs noted during operation.

Carry implements close to the ground, approximately 40 cm (15 in) above ground level.

Stay a safe distance from the edge of cliffs, overhangs and slide areas.

If the machine begins to sideslip on a grade, immediately dispose of the load and turn the machine downhill.

Be careful to avoid the condition which could lead to tipping when working on hills, banks or slopes, and when crossing ditches, ridges or other obstructions.

Work up and down slopes, rather than sideways, whenever possible.

Keep the machine under control and do not work it over its capacity.

Be sure hitch points and the towing device are adequate.

Connect trailing equipment to a drawbar or hitch only.

Never straddle a wire rope cable or similar device, nor allow others to do so.

No personnel should be between the machine and trailing equipment when maneuvering to connect them. Block the tongue or hitch of trailing equipment to align it with the drawbar or hitch.

Machine Parking

Park on a level surface. If necessary to park on a grade, block the machine.

Release the directional pedals to stop the machine.

Engage the hydraulic and directional lock lever.

Engage the swing brake control.

Lower all implements to the ground and apply slight down pressure.

Stop the engine.

Turn the start switch key to the OFF position.

Remove the start switch key and the disconnect switch key.

Product: EXCAVATOR

Model: 215D EXCAVATOR 9TF

Configuration: 215D EXCAVATOR 9TF00001-UP (MACHINE) POWERED BY 3304 ENGINE

Operation and Maintenance Manual 215D AND 219D TRACK-TYPE EXCAVATORS

Media Number -SEBU6317-01

Publication Date -01/02/1990

Date Updated -11/10/2001

Specifications and Model Views

SMCS - 7606

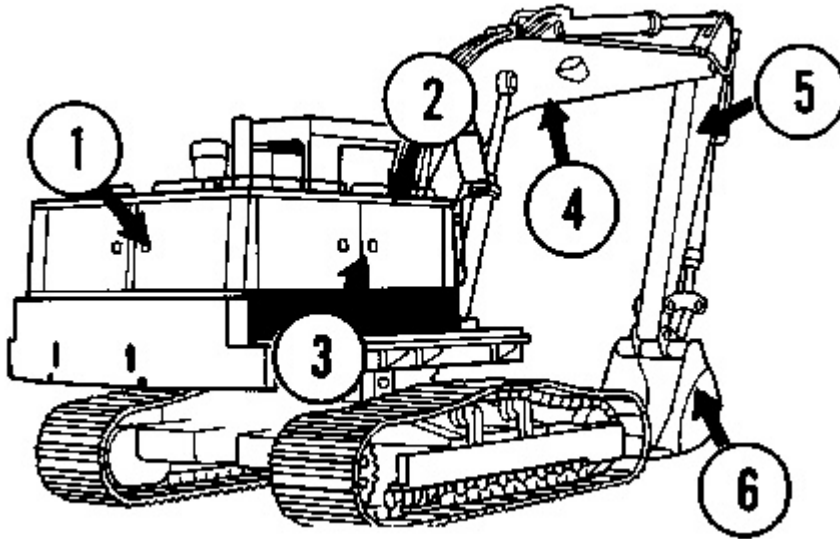

Engine (1), fuel tank (2), hydraulic tank (3), and boom (4), stick (5) and bucket (6).

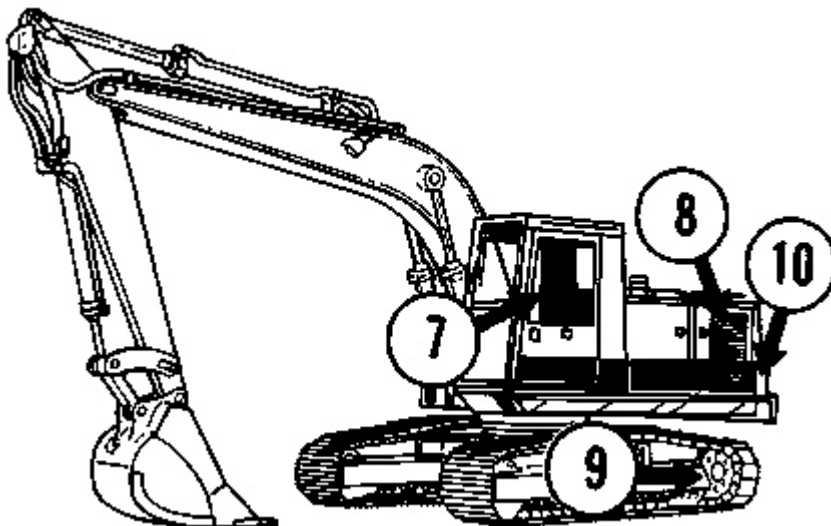

Operator's compartment (7), radiator (8), final drives (9) and counterweight (10).

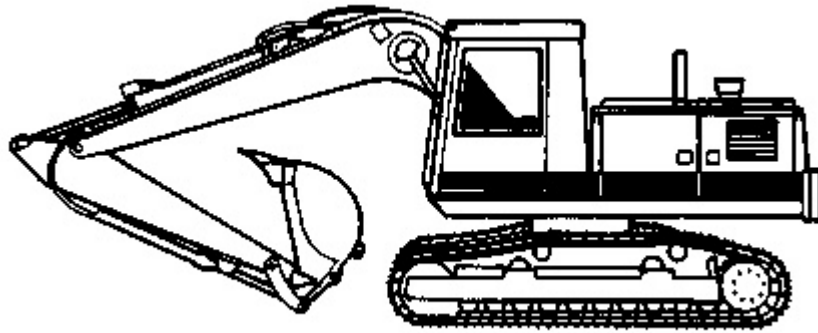

Basic machine shipping specifications are listed below.

215D Track-Type Excavator	
Weight (approximate)	19 940 kg (43,900 lb)
Length (maximum)	8970 mm (29.4 ft)
Width (across track)	2440 mm (8 ft)
Height	3380 mm (11.1 ft)
Ground Clearance	460 mm (1.5 ft)

219D Track-Type Excavator	
Weight (approximate)	21 700 kg (47,800 lb)
Length (maximum)	9420 mm (30.9 ft)
Width (across track)	2740 mm (9 ft)
Height	3110 mm (10.2 ft)
Ground Clearance	366 mm (1.2 ft)

Product: EXCAVATOR

Model: 215D EXCAVATOR 9TF

Configuration: 215D EXCAVATOR 9TF00001-UP (MACHINE) POWERED BY 3304 ENGINE

Operation and Maintenance Manual 215D AND 219D TRACK-TYPE EXCAVATORS

Media Number -SEBU6317-01

Publication Date -01/02/1990

Date Updated -11/10/2001

Product Identification and Serial Number Locations

SMCS - 7606

The Product Identification Number (PIN) will be used to identify a powered machine that is designed for an operator to ride.

Caterpillar products such as earthmoving equipment not designed for an operator to ride (engines, transmissions, etc.) are identified by Serial Numbers. Also, most major Caterpillar attachments are identified by Serial Numbers.

For quick reference, record the identification numbers in the spaces provided below the illustration photographs.

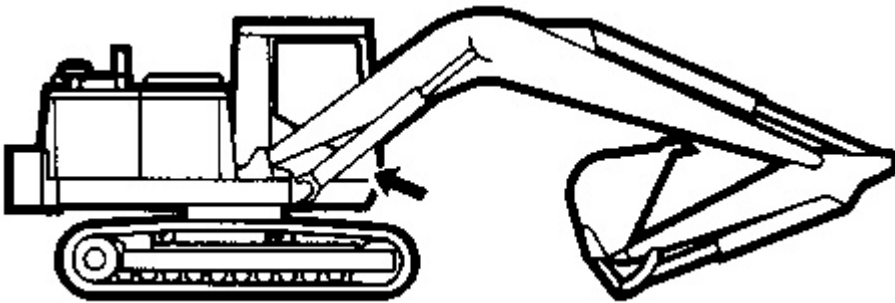

Product Identification Number PIN _____

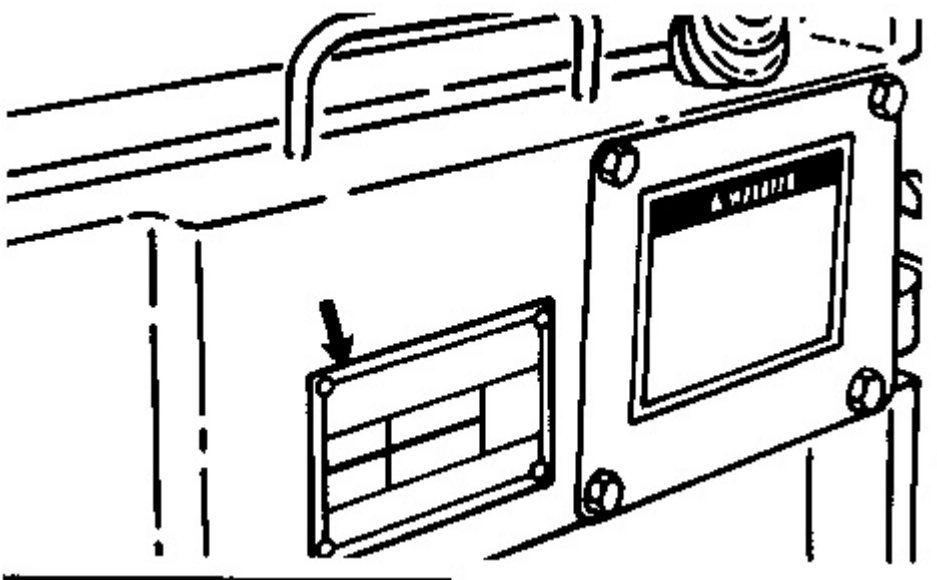

Service Information Number Plate (SIN) _____

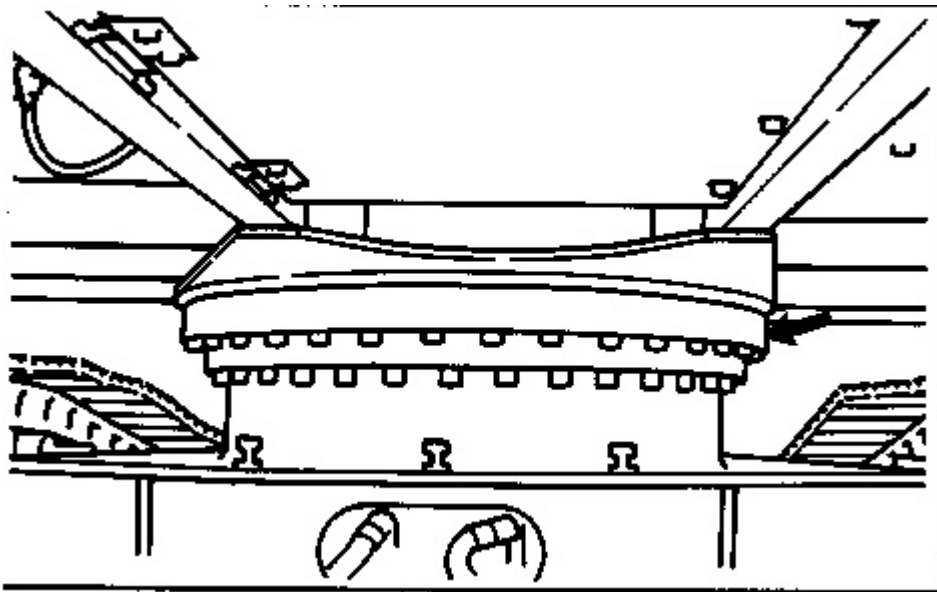

Swing Bearing Serial Number _____

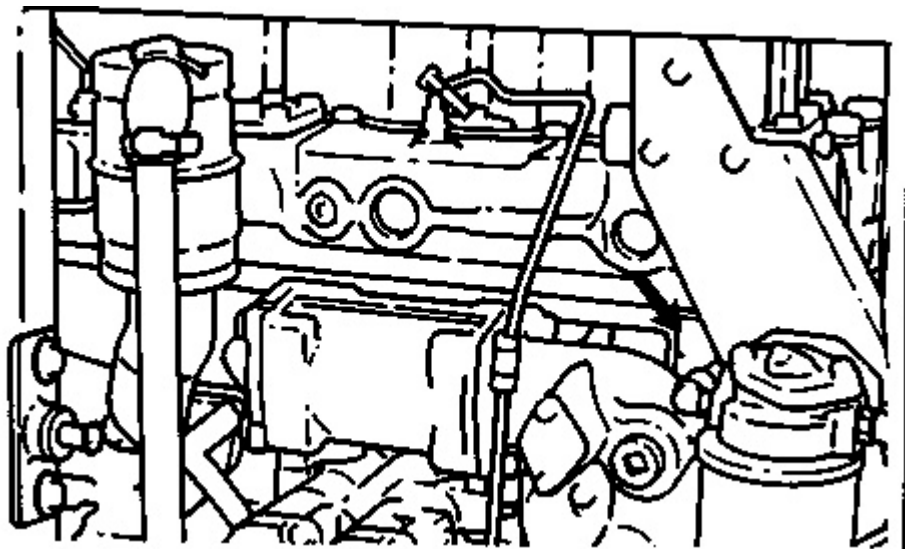



Suggest:

For more complete manuals. Please go to the home page.

<https://www.ebooklibonline.com>

If the above button click is invalid. Please download this document first, and then click the above link to download the complete manual.

Thank you so much for reading

Engine Serial Number _____

Product: EXCAVATOR

Model: 215D EXCAVATOR 9TF

Configuration: 215D EXCAVATOR 9TF00001-UP (MACHINE) POWERED BY 3304 ENGINE

Operation and Maintenance Manual 215D AND 219D TRACK-TYPE EXCAVATORS

Media Number -SEBU6317-01

Publication Date -01/02/1990

Date Updated -11/10/2001

Monitoring Systems and Cab Features

SMCS - 7606

Malfunction Warning System

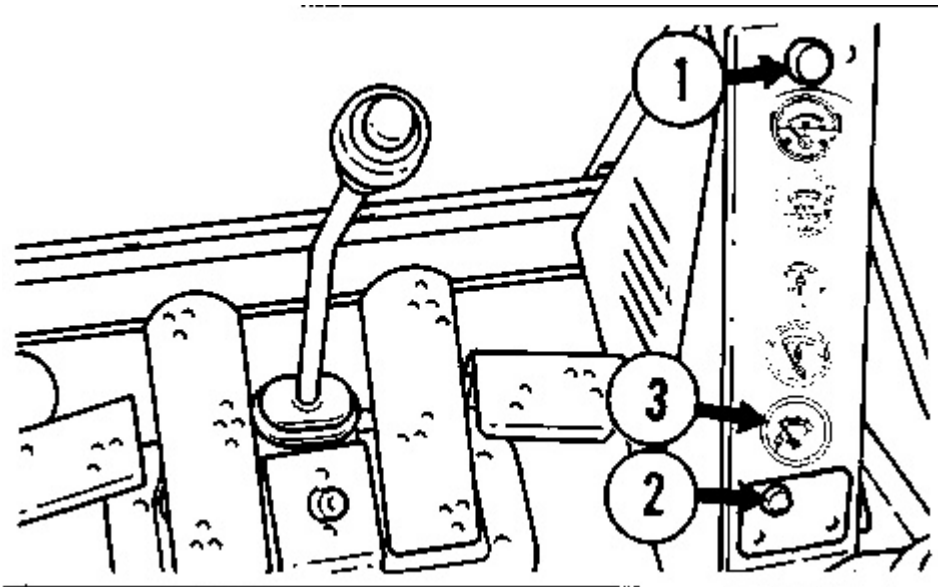

Malfunction Warning Flasher (1) - Flashes to alert the operator to take immediate action to prevent machine damage. The flasher operates if engine oil pressure is too low or engine coolant temperature is too high.

Hydraulic Oil Filter Indicator (2) - Have the filter changed if the indicator lights when the hydraulic oil is warm, and the engine is running at high idle.

Alternator (3) - Indicates the alternator output.

<https://www.ebooklibonline.com>

Hello dear friend!

Thank you very much for reading.

Enter the link into your browser.

The full manual is available for immediate download.

<https://www.ebooklibonline.com>