

Product: TRUCK
Model: 797B TRUCK JSM
Configuration: 797B Off-Highway Truck JSM00001-UP (MACHINE)

Disassembly and Assembly 3524B Engine for Caterpillar Built Machines

Media Number -REN2276-11

Publication Date -01/09/2018

Date Updated -14/09/2018

i06002194

Rocker Shaft and Push Rods - Remove

SMCS - 1102-011

Removal Procedure

Start By:

- A. Remove the valve covers. Refer to Disassembly and Assembly, "Valve Cover - Remove and Install".

NOTICE

Keep all parts clean from contaminants.

Contaminants may cause rapid wear and shortened component life.

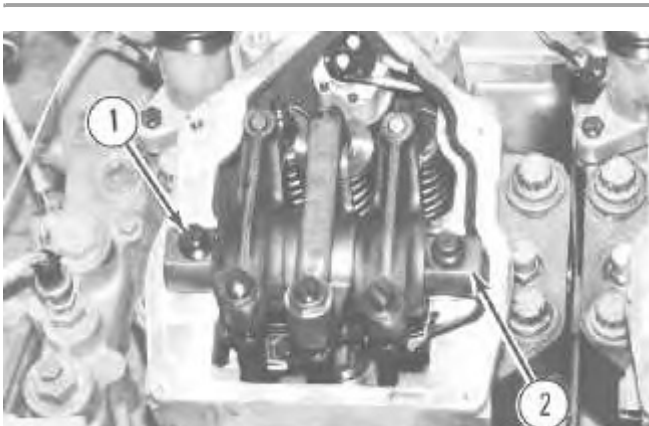

Illustration 1

g00605234

Note: Mark the orientation of the rocker shaft assembly (2) before removal.

1. Remove bolts (1) . Remove rocker shaft assembly (2) from the rocker arm base.

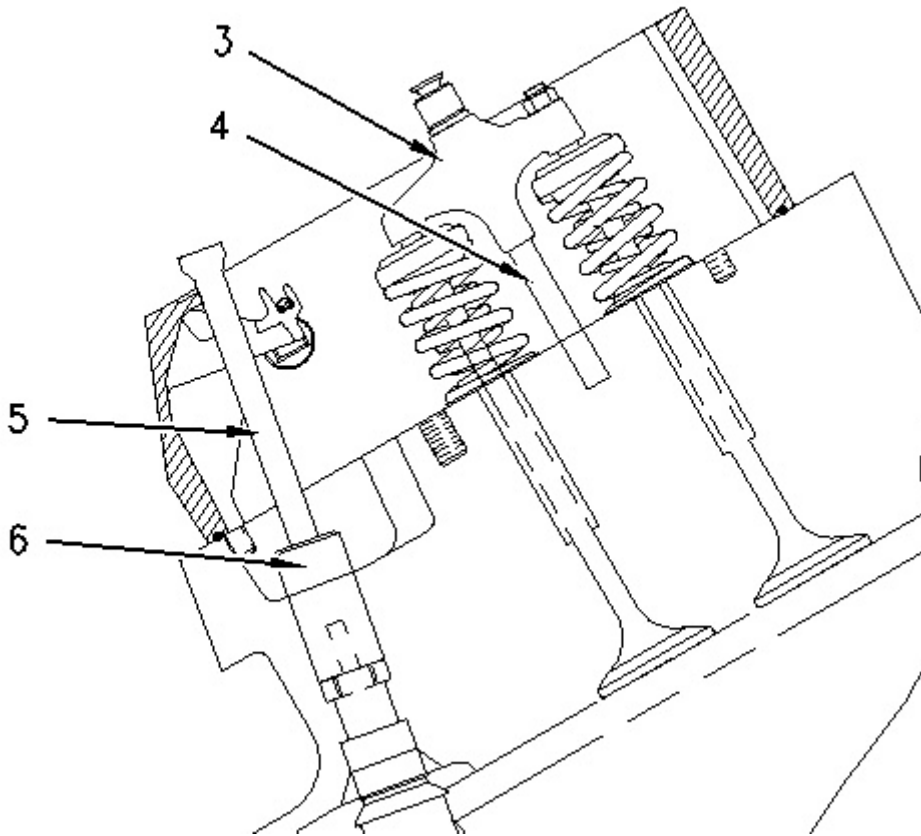

Illustration 2

g00636958

Note: Mark the pushrods and bridge assemblies for identification of location upon assembly.

2. Remove bridge assemblies (3) from dowels (4) (if equipped).
 3. Remove pushrods (5) from the cup of valve lifters (6) .
-

Product: TRUCK
Model: 797B TRUCK JSM
Configuration: 797B Off-Highway Truck JSM00001-UP (MACHINE)

Disassembly and Assembly 3524B Engine for Caterpillar Built Machines

Media Number -REN2276-11

Publication Date -01/09/2018

Date Updated -14/09/2018

i02047273

Rocker Shaft - Disassemble

SMCS - 1102-015

Disassembly Procedure

Table 1

Required Tools			
Tool	Part Number	Part Description	Qty
A	1P-0510	Driver Group	1

Start By:

- a. Remove the rocker shaft assemblies. Refer to Disassembly and Assembly, "Rocker Shaft and Push Rods - Remove".

NOTICE

Keep all parts clean from contaminants.

Contaminants may cause rapid wear and shortened component life.

<https://www.ebooklibonline.com>

Hello dear friend!

Thank you very much for reading.

Enter the link into your browser.

The full manual is available for immediate download.

<https://www.ebooklibonline.com>

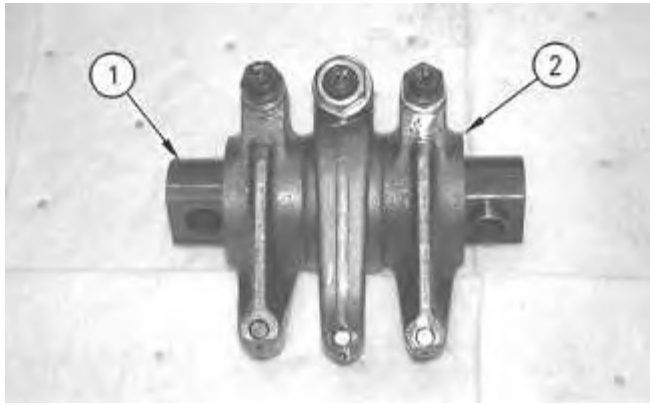

Illustration 1

g00605478

1. Slide shaft (1) out of rocker arms (2). If necessary, remove the dowel from the shaft.

Note: Perform the following Steps for each rocker arm.

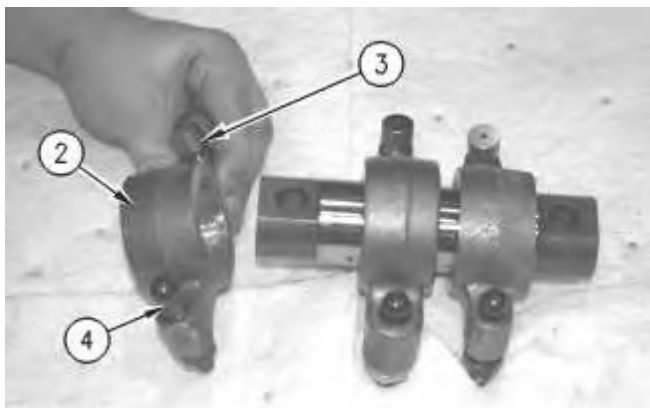
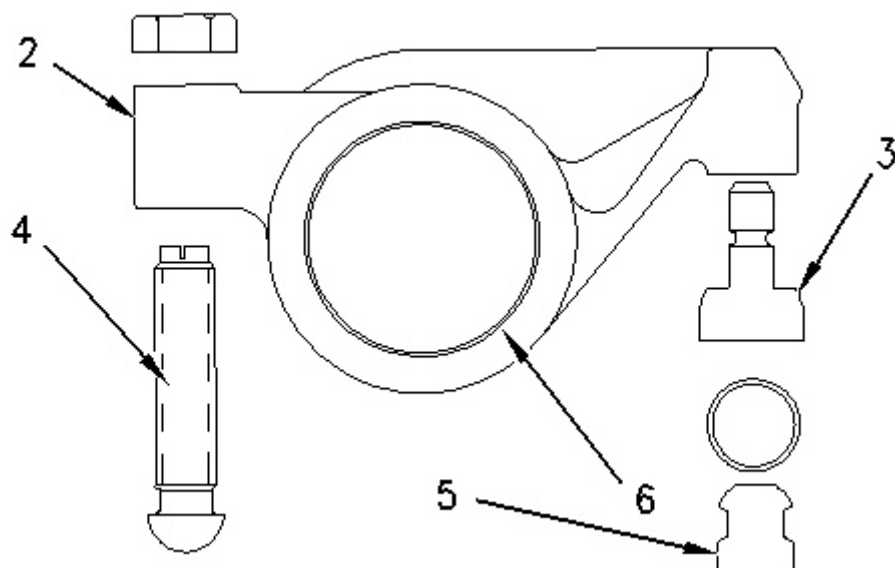

Illustration 2

g00605479



2. Remove adjustment screw (4) and the nut from rocker arm (2).
 3. Use a hammer and a punch to remove socket (3) from rocker arm (2).
 4. Remove button (5) from socket (3). Remove the retaining ring from the button.
 5. Use Tooling (A) to remove sleeve bearing (6) from rocker arm (2).
-

Product: TRUCK
Model: 797B TRUCK JSM
Configuration: 797B Off-Highway Truck JSM00001-UP (MACHINE)

Disassembly and Assembly 3524B Engine for Caterpillar Built Machines

Media Number -REN2276-11

Publication Date -01/09/2018

Date Updated -14/09/2018

i06517032

Rocker Shaft - Assemble

SMCS - 1102-016

Assembly Procedure

Table 1

Required Tools			
Tool	Part Number	Part Description	Qty
A	1P-0510	Driver Group	1

NOTICE

Keep all parts clean from contaminants.

Contaminants may cause rapid wear and shortened component life.

Perform Steps 1 through 4 for each rocker arm.

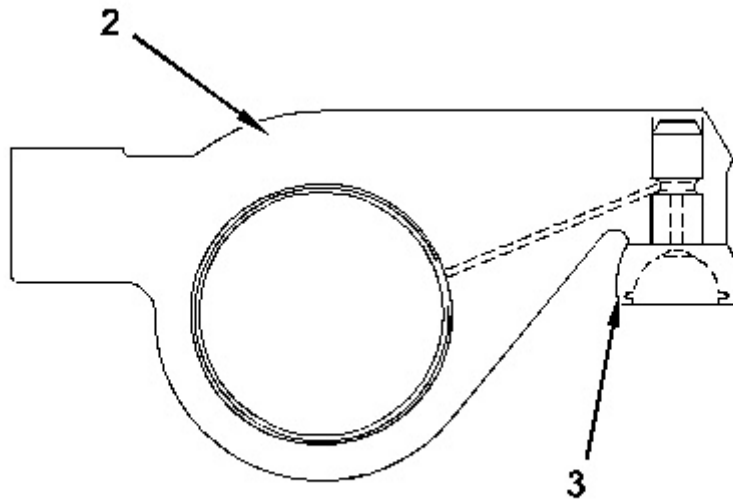

Illustration 1

g01050986

Note: Make sure that the bore of the rocker arm and the sleeve bearing are thoroughly clean.

1. The sleeve bearing and the rocker arm have oil supply holes. The holes must be aligned when the bearing is installed in the rocker arm. Align the joint of the bearing toward the top of the rocker arm. Align the oil hole in the bearing with the oil hole in the rocker arm. Use Tooling (A) to install the sleeve bearing in rocker arm (2).

After the bearing is installed, measure the bore of the bearing. The bore must be 45.077 ± 0.015 mm (1.77468 ± 0.00059 inch). Machine the bearing, if necessary.

2. Align the scribe mark on socket (3) with the scribe mark on rocker arm (2). Press the socket fully into the rocker arm.

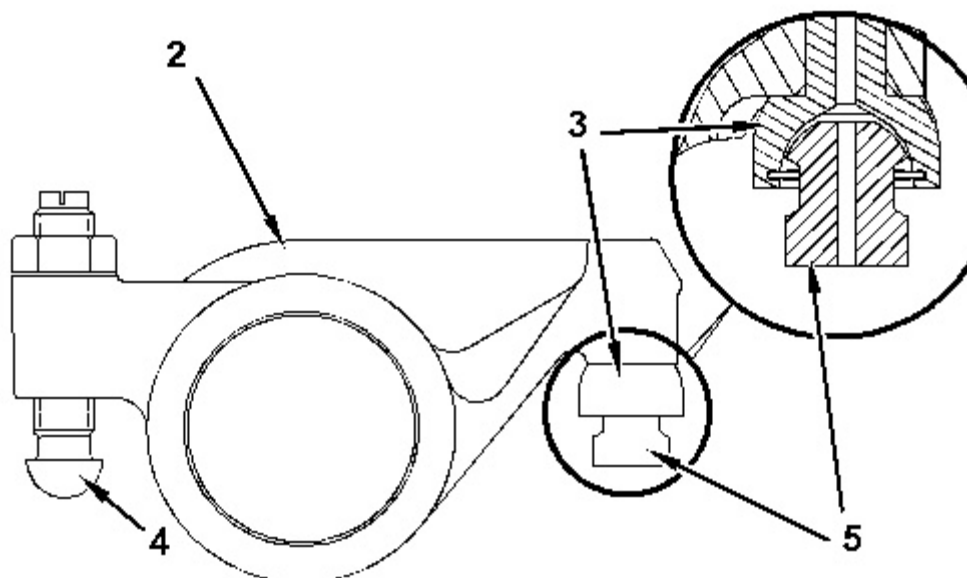

Illustration 2

g01050990

3. Place the retaining ring on button (5). Install the button in socket (3).
4. Install adjustment screw (4) and the nut on rocker arm (2).

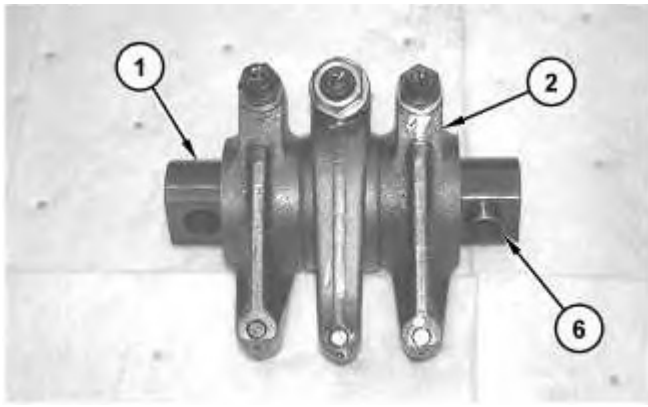

Illustration 3

g02360516

5. If necessary, replace dowel (6) with new. The dowel (6) must project 6.0 mm (0.24 inch) above the surface of the shaft.

Note: The dowel (6) will be on the left side of shaft (1) and the oil hole will be on the right. The dowel (6) and oil hole locations are for the assembly and installation of the rocker arm shaft assemble.

6. Coat the bearings of the rocker arms and coat the shaft with clean engine oil. Install rocker arms (2) on shaft (1).

End By:

- a. Install the rocker shaft assemblies. Refer to Disassembly and Assembly, "Rocker Shaft and Push Rods - Install".
-

Product: TRUCK
Model: 797B TRUCK JSM
Configuration: 797B Off-Highway Truck JSM00001-UP (MACHINE)

Disassembly and Assembly 3524B Engine for Caterpillar Built Machines

Media Number -REN2276-11

Publication Date -01/09/2018

Date Updated -14/09/2018

i07163868

Rocker Shaft and Pushrod - Install

SMCS - 1102-012; 1208-012

Installation Procedure

NOTICE

Keep all parts clean from contaminants.

Contaminants may cause rapid wear and shortened component life.

Note: For installing valve bridges with a dowel refer to Step 1 through Step 4. For installing floating bridge assemblies refer to Step 5 through Step 6.

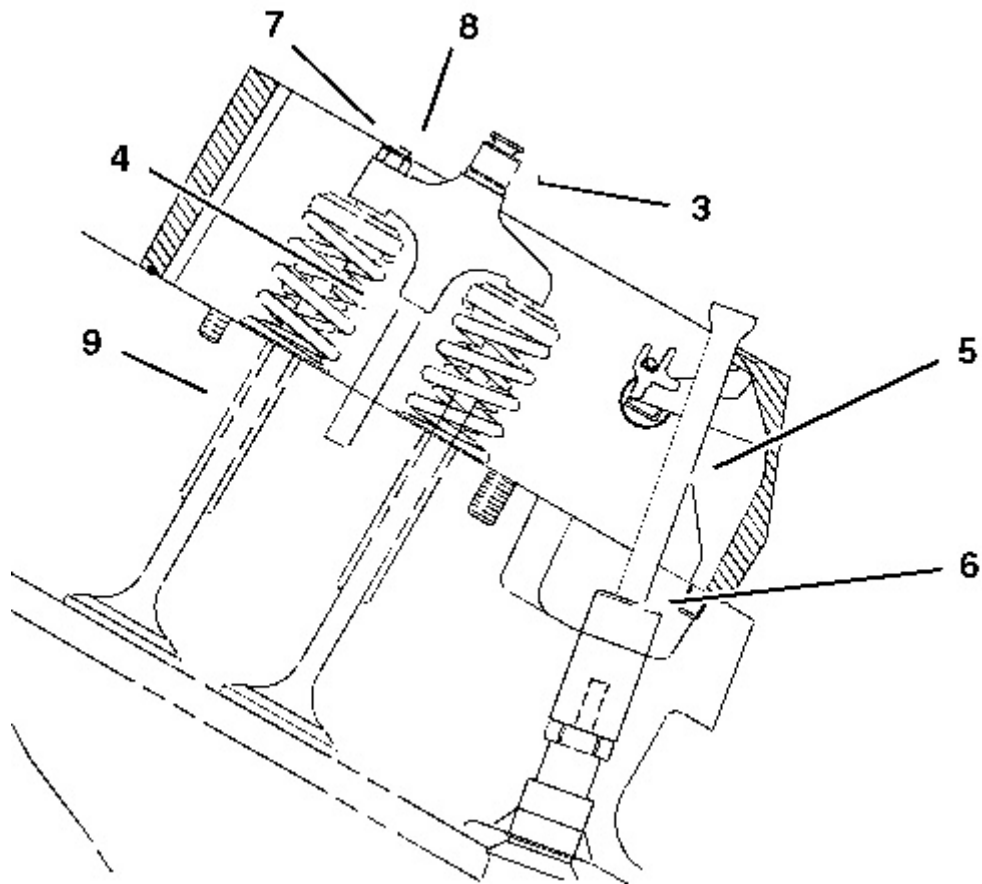

Illustration 1

g01051014

1. Loosen adjustment screw (7) and jam nut (8) on the bridge assembly.
2. Coat these items with clean engine oil: dowels (4), the receptacle of the bridge for the dowels and the uppermost contact surface of bridge assembly (3).
3. Place the bridge assembly into position on the dowel. Apply 1 to 14 N·m (1 to 10 lb ft) of downward force on the uppermost contact surface of bridge assembly (3). While you apply the force, turn adjustment screw (7) until the screw contacts valve stem (9).

Adjust screw an additional 20 to 30 degrees (1/3 to 1/2 of the hex) to straighten the dowel in the guide.

Note: The bridges should be oriented so that the bridge marked “EX” is above the exhaust valves. The part numbers on the bridges should face the front of the engine.

4. Hold the adjustment screw in position and tighten jam nut (8) to a torque of 30 ± 4 N·m (22 ± 3 lb ft).
-

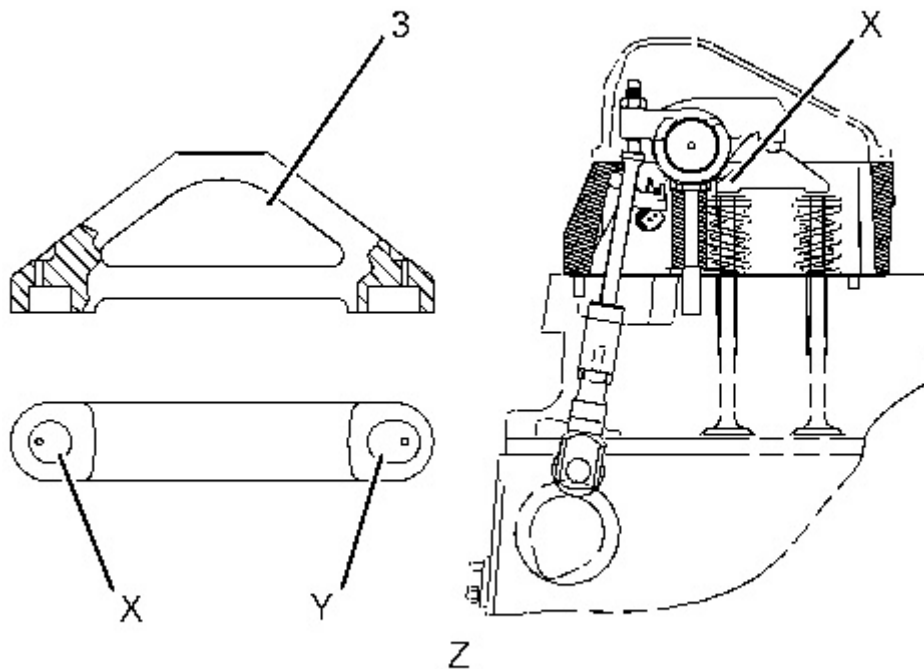

Illustration 2

g01946786

Floating valve bridge

(X) Round pocket

(Y) Slotted pocket

(Z) Outside of engine

5. Apply clean engine oil to the contact surface of bridge assemblies (3) and the valve stems. Install bridge assemblies (3) on the valve stems.
6. Install the bridge assemblies with the round pocket toward the outside of the engine. Refer to Illustration 2.

Note: Installing each pushrod in the original location is critical.

7. Coat pushrods (5) and the cups of the valve lifters (6) with clean engine oil. Place the pushrods into position on the valve lifters.

NOTICE

Ensure that the crankshaft and the camshafts are in time with each other. Also ensure that the adjustment screws in the rocker arms are loosened completely before the bolts on the rocker shaft are tightened or damage to the valves and the pistons may occur.

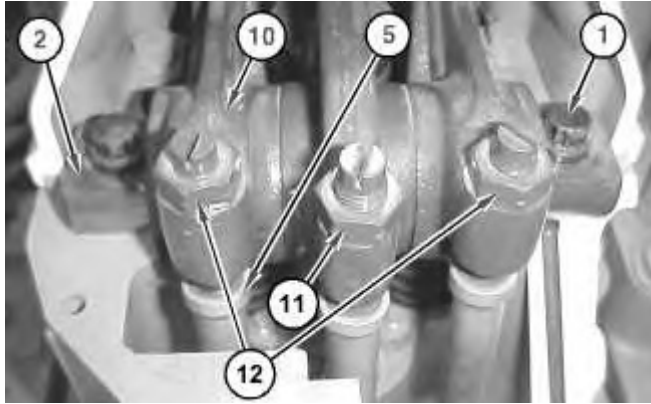

Illustration 3

g01051017

NOTICE

If the rocker shaft is not positioned correctly, the oil supply to the sleeve bearings in the rocker arm will be shut off. This will cause seizure of the bearings and severe damage to the engine.

Be sure to orient the rocker shaft in the correct position.

8. Place rocker shaft assembly (2) in position on the rocker arm base. Make sure that rocker arms (10) and pushrods (5) are aligned. Install bolts (1). If bolt (1) is a 5/8 inch bolt, tighten to a torque of $215 \pm 40 \text{ N}\cdot\text{m}$ ($159 \pm 30 \text{ lb ft}$). If bolt (1) is a 1/2 inch bolt, tighten to a torque of $120 \pm 20 \text{ N}\cdot\text{m}$ ($88 \pm 15 \text{ lb ft}$).
9. Adjust the valve bridge and the valve lash according to Testing and Adjusting, "Valve Lash and Valve Bridge Adjustment".
10. Adjust the fuel injection pump according to Testing and Adjusting, "Fuel Injector Adjustment".

Tighten nuts (12) to a torque of $70 \pm 15 \text{ N}\cdot\text{m}$ ($52 \pm 11 \text{ lb ft}$).
11. Tighten nut (11) for the rocker arm of the fuel injection pump. If nut (11) is 5/8 inch thread, tighten to a torque of $120 \pm 15 \text{ N}\cdot\text{m}$ ($89 \pm 11 \text{ lb ft}$). If nut (11) is 1/2 inch thread, tighten to a torque of $70 \pm 15 \text{ N}\cdot\text{m}$ ($52 \pm 11 \text{ lb ft}$).

End By:

- a. Install the valve covers. Refer to Disassembly and Assembly, "Valve Cover - Remove and Install".
-

Product: TRUCK
Model: 797B TRUCK JSM
Configuration: 797B Off-Highway Truck JSM00001-UP (MACHINE)

Disassembly and Assembly 3524B Engine for Caterpillar Built Machines

Media Number -REN2276-11

Publication Date -01/09/2018

Date Updated -14/09/2018

i02415328

Electronic Unit Injector - Remove

SMCS - 1290-011

Removal Procedure

Table 1

Required Tools			
Tool	Part Number	Part Description	Qty
A	5F-4764	Pry Bar	1

Start By:

- Remove the rocker shaft assembly and the pushrods. Refer to Disassembly and Assembly, "Rocker Shaft Assembly and Push Rods - Remove".

NOTICE

Keep all parts clean from contaminants.

Contaminants may cause rapid wear and shortened component life.

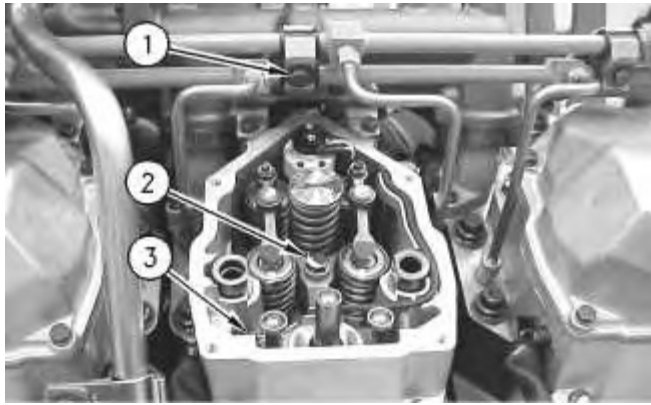

Illustration 1

g00903832

1. Remove bolt (1) and the clamp.
2. Remove bolt (2) and the clamp.
3. Disconnect harness assembly (3).

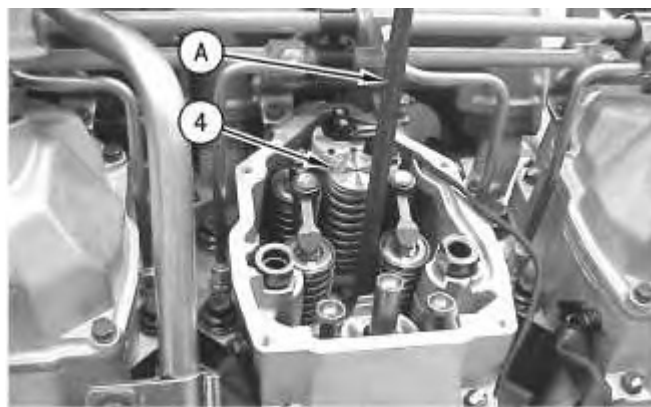

Illustration 2

g00903932

4. Use Tooling (A) to remove electronic unit injector (4).
 5. Remove fuel / fluids from the cylinder. **WARNING!** Turning over (cranking) an engine with an injector removed could result in personal injury or death from fluids escaping at high velocity.
-

Product: TRUCK
Model: 797B TRUCK JSM
Configuration: 797B Off-Highway Truck JSM00001-UP (MACHINE)

Disassembly and Assembly 3524B Engine for Caterpillar Built Machines

Media Number -REN2276-11

Publication Date -01/09/2018

Date Updated -14/09/2018

i02415334

Electronic Unit Injector - Install

SMCS - 1290-012

Installation Procedure

Table 1

Required Tools			
Tool	Part Number	Part Description	Qty
B	9U-6862	Tapered Brush	1
C	4C-5027	Tap Wrench	1
D	4C-6774	Vacuum Gun Kit	1
E	1P-0808	Multipurpose Grease	1
F	1U-5512 or 8T-7765	Abrasive Material or Surface Reconditioning Pad	1

NOTICE

Keep all parts clean from contaminants.

Contaminants may cause rapid wear and shortened component life.

NOTICE

Remove all carbon deposits from the angled surface at the bottom of the cylinder head bore for the fuel injection pump. Failure to clean this area may prevent the fuel injection pump from seating properly. This could result in failure of the fuel injection pump due to leakage of exhaust gas into the fuel passage.

1. It is important to clean the cylinder head bore for the electronic unit injector before you install the electronic unit injector. Use the following procedure to clean the bore.

Note: A fine grade of Scotch Brite material is recommended for cleaning the cylinder head bore for the electronic unit injector. The product is available as Tooling (F).

- a. Place a 38 mm (1.5 inch) square piece of Scotch Brite material on the end of Tooling (B).

Note: It should not be necessary to use a power tool to clean the cylinder head bore for the electronic unit injector.

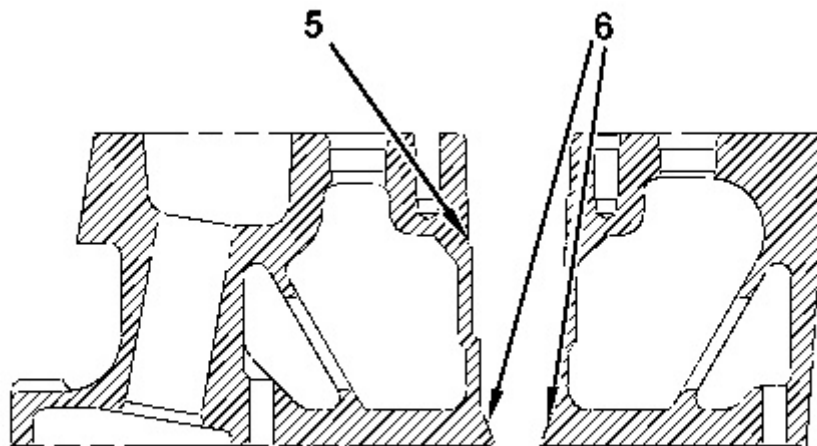

Illustration 1

g01051051

- b. Hold the brush with Tooling (C). Insert the brush into bore (5). Rotate the Scotch Brite material against the lower surface of bore (6). Continue cleaning until the surface is smooth and shiny.

Note: Tooling (D) is recommended for cleaning loose particles from the bore. The vacuum is operated with pressurized air.

- c. Remove all loose particles from the bore.

2. Remove any fuel / fluid that may have accumulated before installing the injector.
-

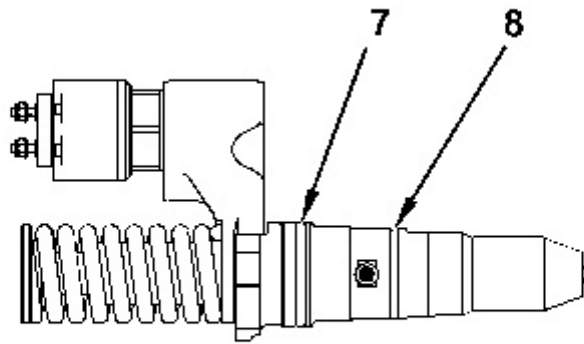

Illustration 2

g01051052

3. Inspect O-ring seals (7) and (8) for good condition. Obtain new O-ring seals, if necessary. Coat the O-ring seals and coat the cylinder head bore for the electronic unit injector with Tooling (E).
4. Press the electronic unit injector into the bore of the cylinder head. Do not strike the electronic unit injector. Center the solenoid between the valve springs.

Note: Adjust the height of the electronic unit injector according to the Service Manual, "Specifications".

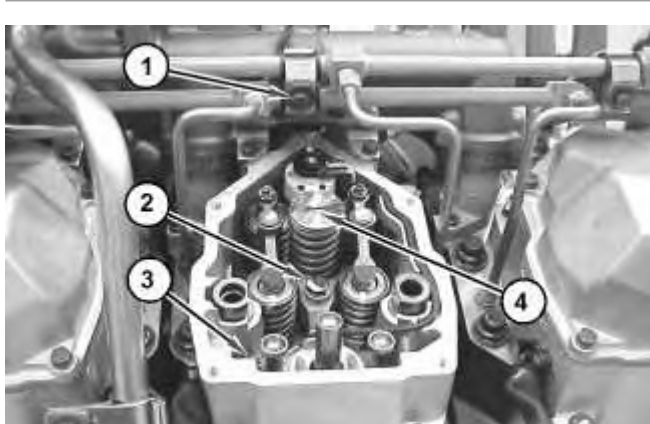

Illustration 3

g01052571

5. To seat electronic unit injector (4) into the bore, install the clamp with bolt (2) and the washer. Tighten the bolt to a torque of 65 ± 7 N·m (48 ± 5 lb ft).
6. Connect harness assembly (3) to the connector. Tighten the terminal nuts to a torque of 1.70 ± 0.25 N·m (15 ± 2 lb in).
7. Press the harness assembly into the groove in the valve cover base.

8. Install bolt (1) and the clamp.

End By:

- a. Install the rocker shaft assembly and the pushrods. Refer to Disassembly and Assembly, "Rocker Shaft and Push Rods - Install".
-

Product: TRUCK
Model: 797B TRUCK JSM
Configuration: 797B Off-Highway Truck JSM00001-UP (MACHINE)

Disassembly and Assembly 3524B Engine for Caterpillar Built Machines

Media Number -REN2276-11

Publication Date -01/09/2018

Date Updated -14/09/2018

i02414981

Cylinder Head - Remove

SMCS - 1100-011

Removal Procedure

Table 1

Required Tools			
Tool	Part Number	Part Description	Qty
A	138-7573	Link Bracket	2

Start By:

- a. Remove the valve cover base. Refer to Disassembly and Assembly, "Valve Cover Base - Remove and Install".

NOTICE

Keep all parts clean from contaminants.

Contaminants may cause rapid wear and shortened component life.

NOTICE

Do not allow dirt to enter the fuel system. Thoroughly clean the area around a fuel system component that will be disconnected. Fit a suitable cover over disconnected fuel system component.



Suggest:

For more complete manuals. Please go to the home page.

<https://www.ebooklibonline.com>

If the above button click is invalid. Please download this document first, and then click the above link to download the complete manual.

Thank you so much for reading

NOTICE

Care must be taken to ensure that fluids are contained during performance of inspection, maintenance, testing, adjusting, and repair of the product. Be prepared to collect the fluid with suitable containers before opening any compartment or disassembling any component containing fluids.

Refer to Special Publication, NENG2500, "Dealer Service Tool Catalog" for tools and supplies suitable to collect and contain fluids on Cat products.

Dispose of all fluids according to local regulations and mandates.

1. Drain the coolant from the cooling system. Refer to Operation and Maintenance Manual, "Cooling System Coolant - Change".

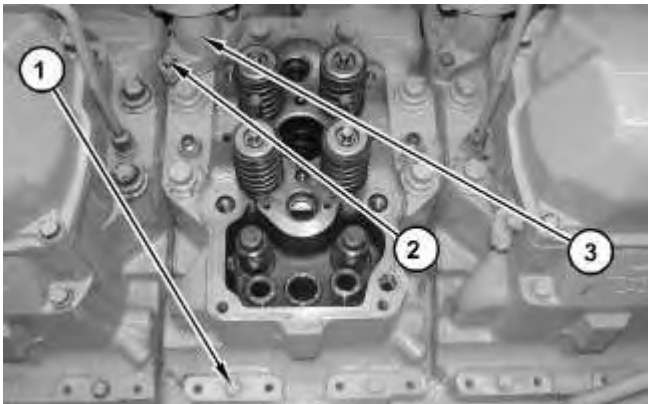

Illustration 1

g01053854

2. Remove bolts (1) and (2). Remove tube (3).

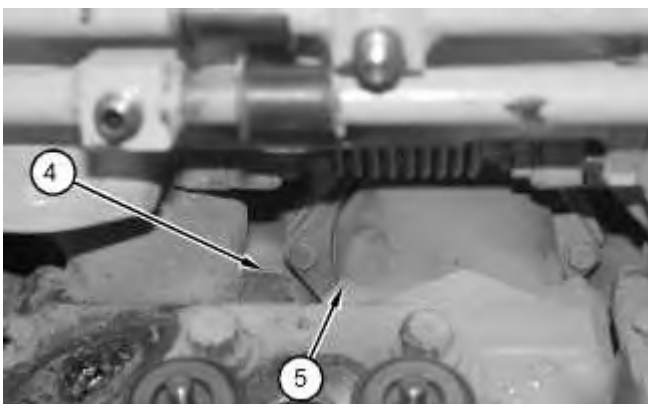

Illustration 2

g01053859

3. Remove four bolts (4) (not shown) from exhaust tube assembly and remove four bolts (5) (not shown) from inlet tube assembly.
-

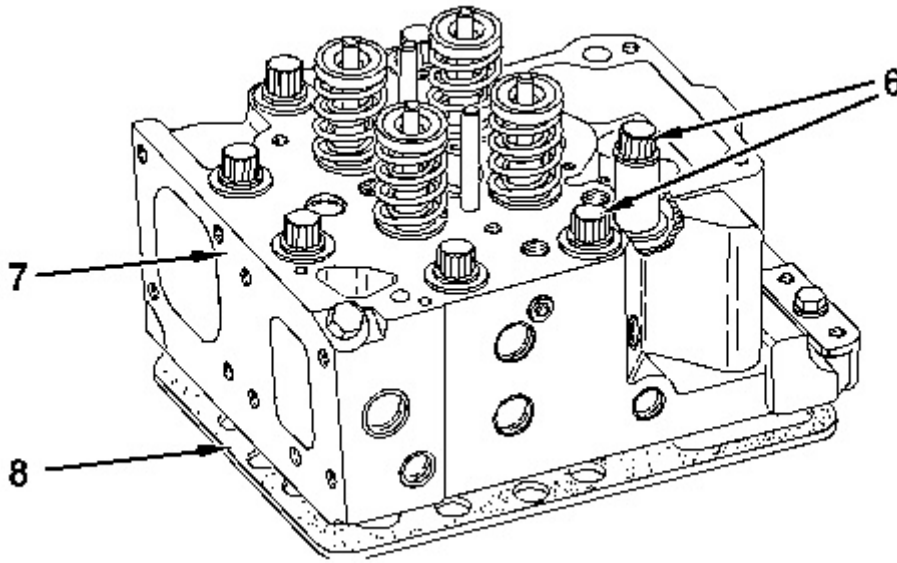

Illustration 3

g01053860

4. Remove bolts (6). Use a suitable lifting device and Tooling (A) in order to remove cylinder head assembly (7). The weight of cylinder head assembly (7) is approximately 47 kg (104 lb). Remove gasket (8).
-

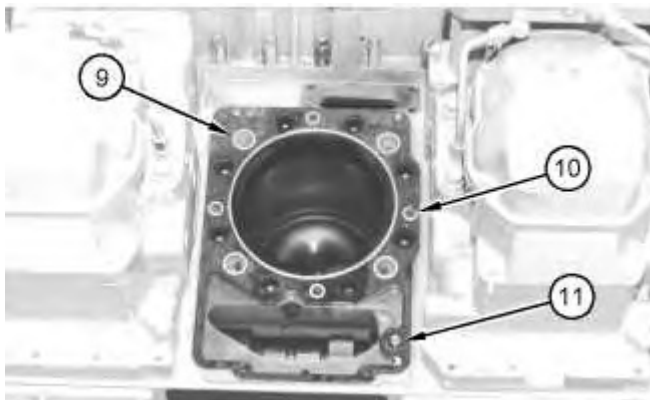

Illustration 4

g01053975

5. Remove seals (9) and (10), and O-ring seal (11) from the spacer plate.
-

<https://www.ebooklibonline.com>

Hello dear friend!

Thank you very much for reading.

Enter the link into your browser.

The full manual is available for immediate download.

<https://www.ebooklibonline.com>