

Product: TRUCK

Model: 793F XQ TRUCK SND

Configuration: 793F XQ Off-Highway Truck SND00001-UP (MACHINE) POWERED BY C175-16 Engine

Disassembly and Assembly 793F Off-Highway Truck Machine Systems

Media Number -KENR8579-09

Publication Date -01/10/2018

Date Updated -01/10/2018

i07077954

Piston Pump (Hydraulic Fan, Steering) - Assemble

SMCS - 5070-016

Assembly Procedure

Table 1

Required Tools			
Tool	Part Number	Part Description	Qty
A	1P-2420	Transmission Stand Group	1
B	439-3940	Bracket As	4
	168-8395	Socket	1
	8F-4678	Adapter	1
C	6V-9452	Drive Adapter	2
	6V-9451	Torque Tube	1
	9S-7352	Torque Wrench	1
E	1P-0510	Driver Group	1
F	136-1452	Retaining Ring Pliers As	1
G	137-1331	Alignment Plug	1
H	137-1329	Pins	3
J	129-3876	Measuring Bell	1
K	137-1326	Measuring Hub	1
L	4C-4030	Thread Lock Compound	1
M	6V-2055	Grease	1

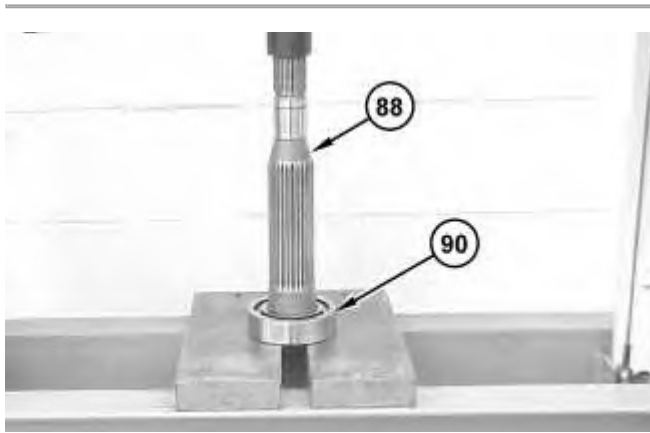


Illustration 1

g02033203

1. Use a suitable press to install shaft (88) into bearing (90).



Illustration 2

g02033202

2. Install retaining ring (89) onto shaft (88).

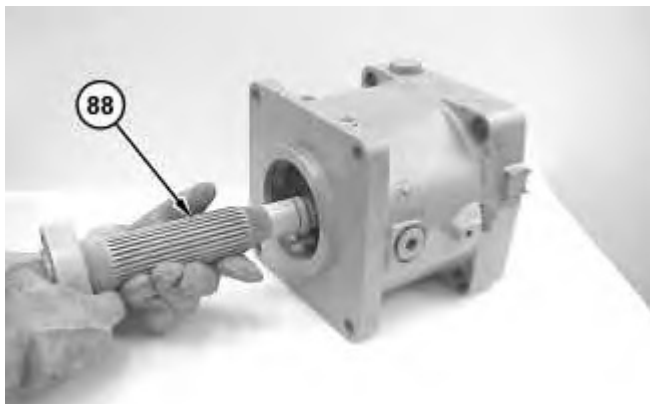


Illustration 3

g02034149

3. Lower the temperature of the shaft assembly (88). Install the shaft assembly.



Illustration 4

g02034152

4. Install O-ring seal (87) and cover (86).



Illustration 5

g02034154

5. Use Tooling (F) to install retaining ring (85).

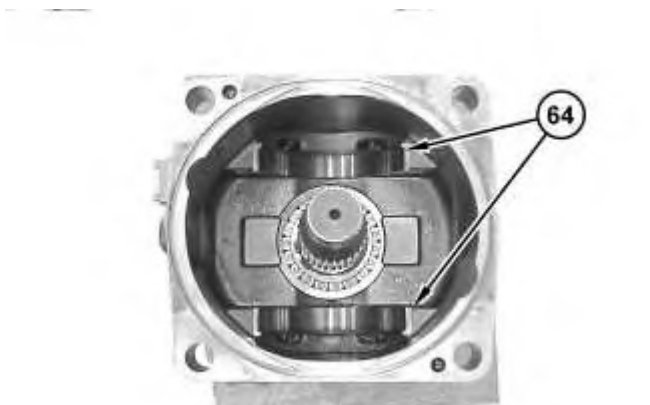


Illustration 6

g02033041

6. Install bearing sleeves (64).

<https://www.ebooklibonline.com>

Hello dear friend!

Thank you very much for reading.

Enter the link into your browser.

The full manual is available for immediate download.

<https://www.ebooklibonline.com>

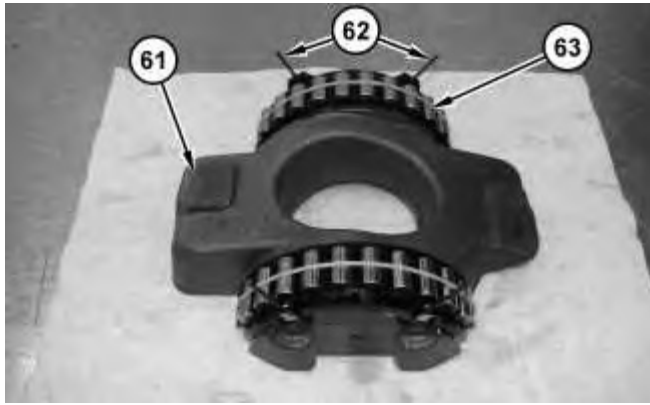


Illustration 7

g02036558

7. Install bearings (63) and pins (62) onto swashplate assembly (61). Install rubber bands to secure bearings (63) to swashplate assembly (61).



Illustration 8

g02036976

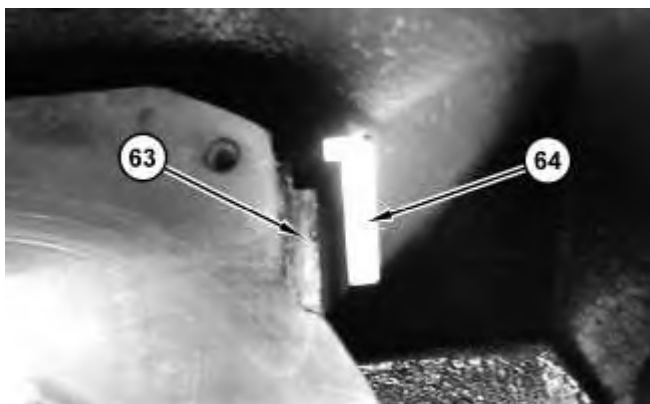


Illustration 9

g02036973

8. Install swashplate assembly (61). Cut and remove the rubber bands. Ensure that bearings (63) and bearing sleeves (64) are properly aligned.

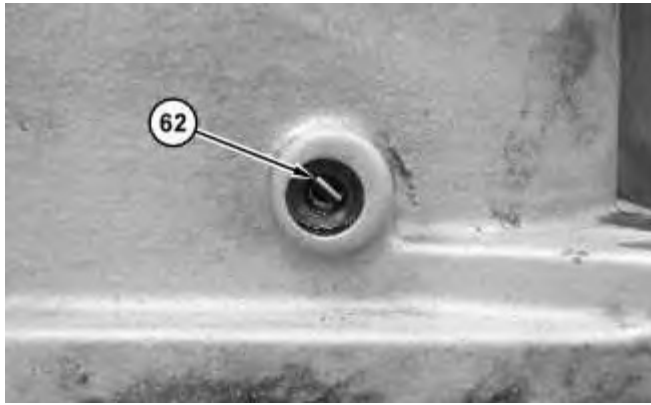


Illustration 10

g02036953

9. Line up pins (62) with the center of the holes in the housing by moving the bearings.

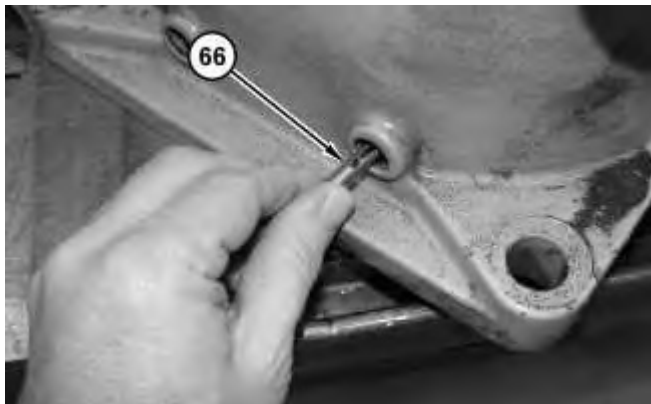


Illustration 11

g02033058

10. Install guide pins (66).

Note: Guide pins (66) are slotted to secure pins (62).

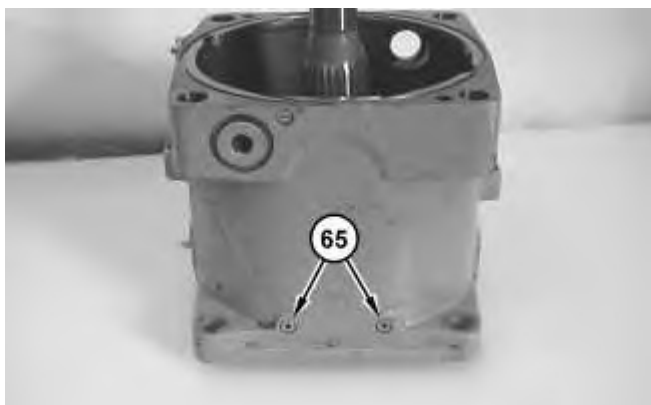


Illustration 12

g02033142

11. Install plugs (65).

12. The following steps are the procedure to determine the correct shim thickness for the rotating group:

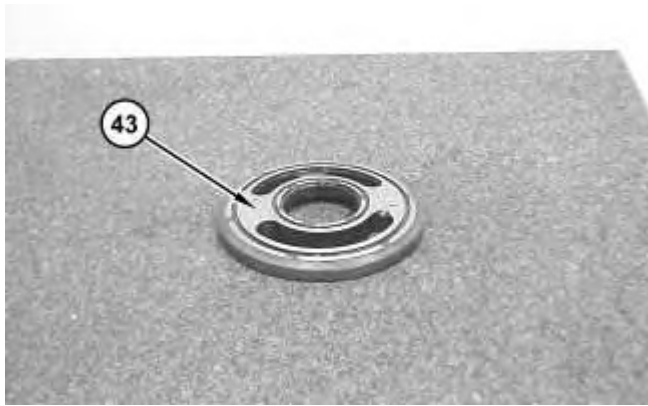


Illustration 13

g02036333

- a. Place port plate (43) onto a surface plate. The flat side of the port plate should rest on the surface plate.

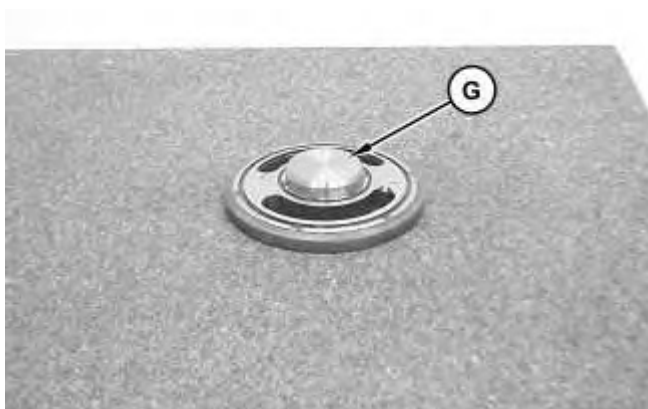


Illustration 14

g02046116

- b. Place Tooling (G) on the inside diameter of the port plate. The chamfered side faces upward.

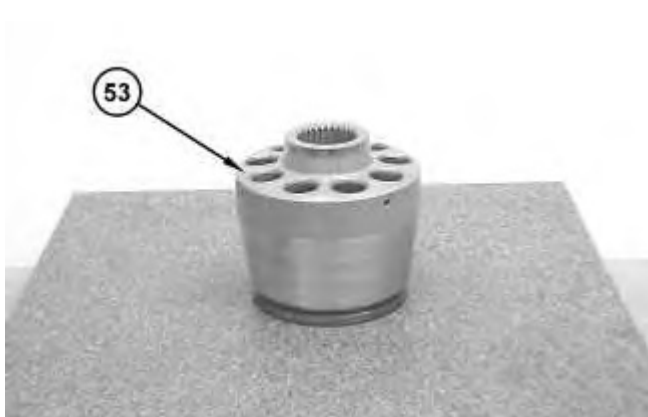


Illustration 15

g02036334

c. Install barrel assembly (53) onto Tooling (G).

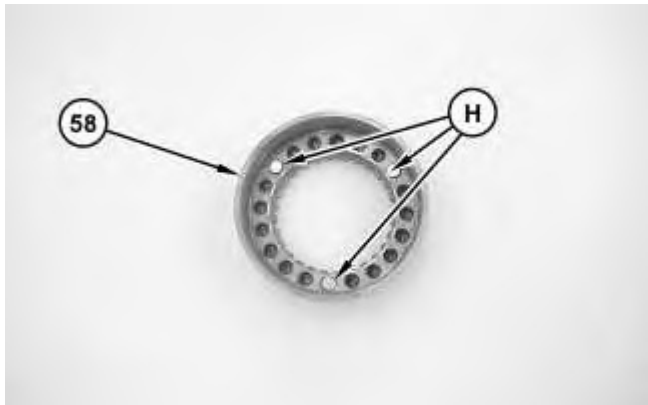


Illustration 16

g02036353

d. Install Tooling (H) into spring retainer (58).

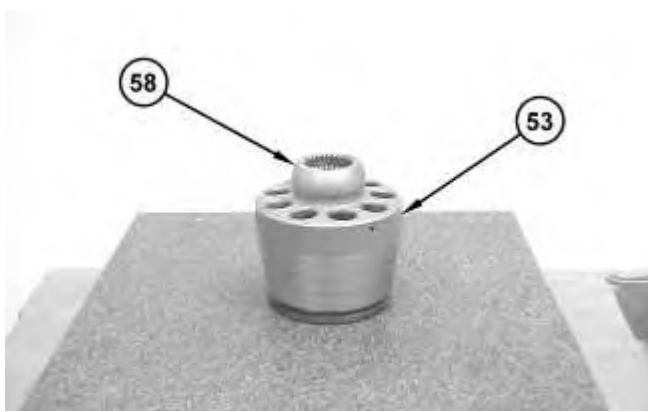


Illustration 17

g02036393

e. Make sure that all the springs and shims have been removed from barrel (53). Install retainer (58) and Tooling (H) on the barrel (53).



Illustration 18

g02036534

f. Install plate (57) onto the retainer.

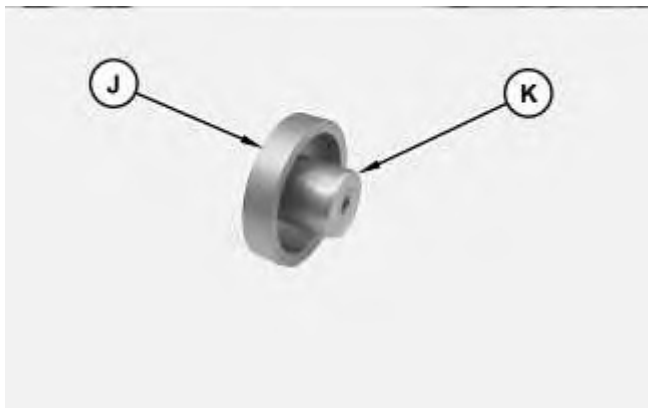


Illustration 19

g02048953

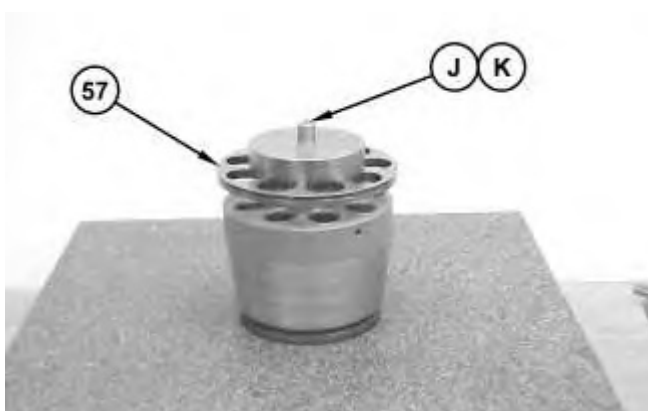


Illustration 20

g02061776

- g. Bolt Tooling (J) and Tooling (K) together. Place the Tooling on top of plate (57).

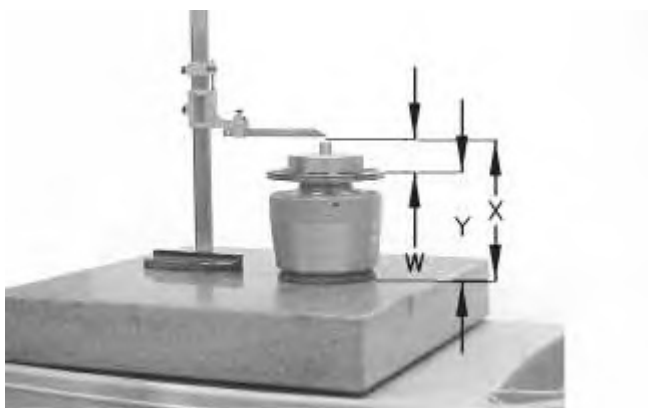


Illustration 21

g00606599

- h. Use a Vernier scale height gauge or a similar tool to measure the dimension in Step 12.i.
- i. Measure the distance from the top of the surface plate to the top of Tooling (J). Record this dimension as Dimension (X).

Note: The following calculations are used to determine the shim thickness and the Lift-Off limitation height.

- Dimension (X) minus Dimension (W) equals Dimension (Y).
- Dimension (Z) minus Dimension (Y) equals Shim thickness to use to obtain the correct Lift-Off Limitation Height.

Note: Dimension (Y) is the Lift-Off Limitation Height without the shim. The correct Lift-Off Limitation Height of the pump is 146.10 mm +0.0, -0.25. Call this height Dimension (Z).



Illustration 22

g02035913

13. Install springs (59) into the spring retainer (58). Install shims (60) onto springs (59). Refer to Step 12.i for the correct size shims.

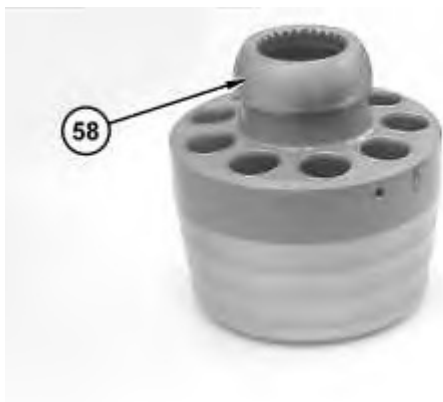


Illustration 23

g02033008

14. Install spring retainer (58).
-



Illustration 24

g02033005

15. Install pistons (56) into plate (57) and into barrel (53).

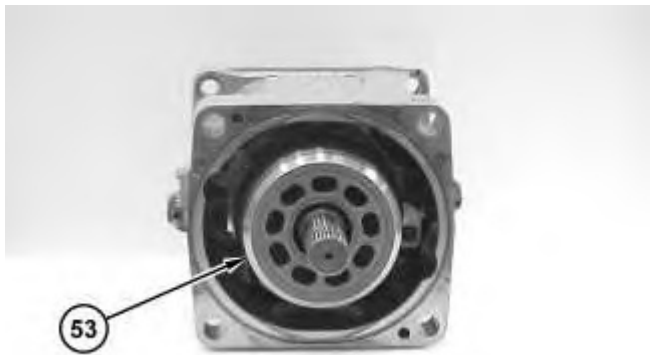


Illustration 25

g02033002

16. Place the pump on a level surface. Install barrel assembly (53). Keep the barrel assembly together with the pistons.

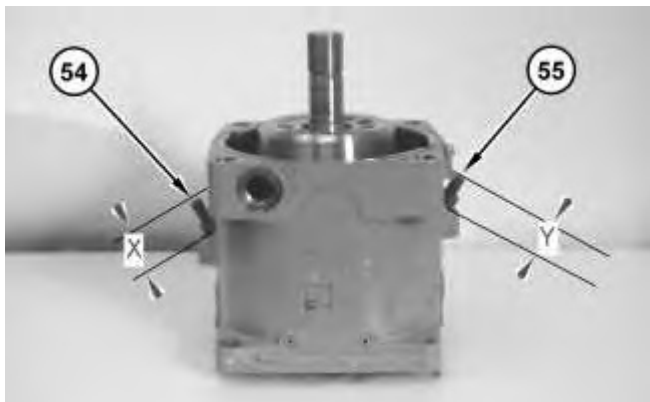


Illustration 26

g02053993

17. Install threaded pin (54). Install threaded pin (55). Refer to recorded measurements during disassembly.

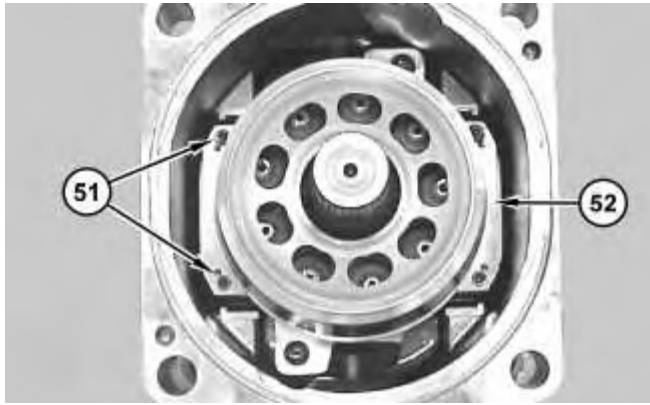


Illustration 27

g02031496

18. Install retainers (52). Apply Tooling (L) onto new bolts (51). Install bolts (51) to a torque of 18 N·m (160 lb in).

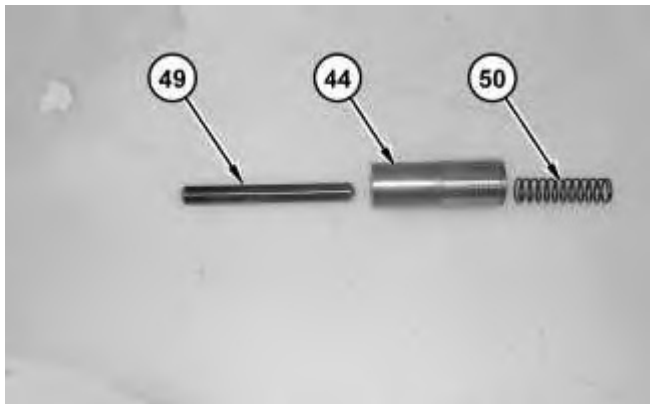


Illustration 28

g02031473

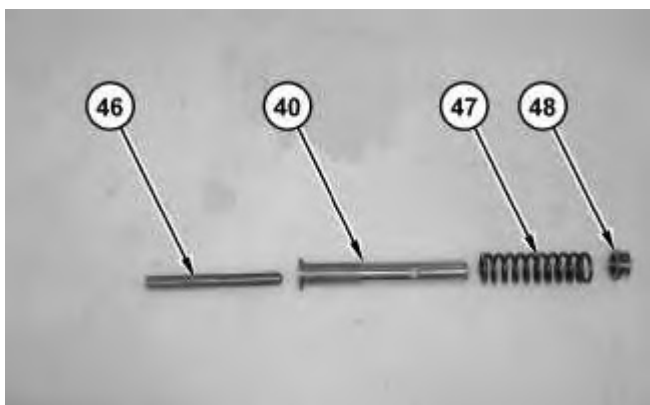


Illustration 29

g02031474

19. Install rod (49) and spring (50) onto piston assembly (44). Install rod (46), spring (47), and retainer (48) onto piston assembly (40).

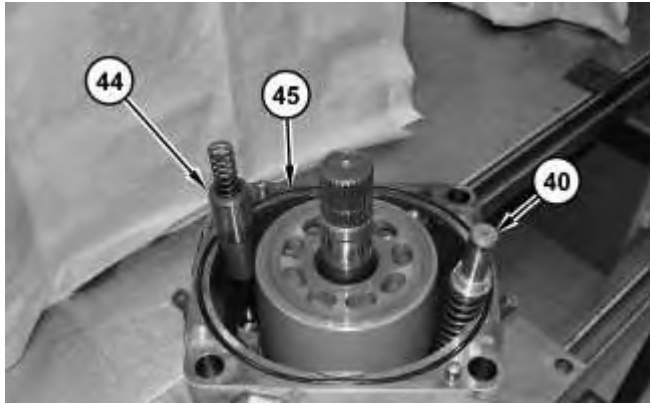


Illustration 30

g02036994

20. Install piston assembly (40), O-ring seal (45), and piston assembly (44).
21. Repeat Steps 6 through Steps 20 for the tandem pump.

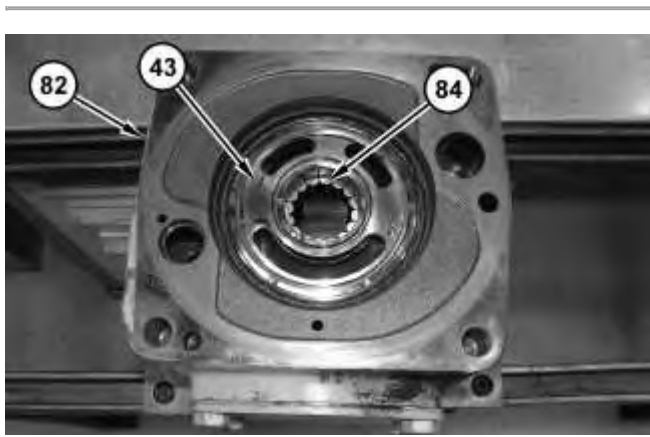


Illustration 31

g02037931

22. Install bearing (84) into head (82). Apply Tooling (M) onto port plate (43). Install port plate (43) onto head (82).

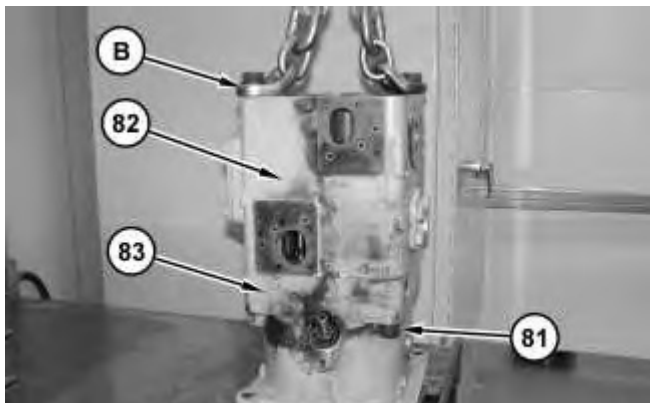


Illustration 32

g02037549

WARNING

Improper assembly of parts that are spring loaded can cause bodily injury.

To prevent possible injury, follow the established assembly procedure and wear protective equipment.

23. Attach Tooling (B) and a suitable lifting device onto head (82). Install head (82) onto pump housing (83). The weight of head (82) is approximately 64 kg (140 lb).
24. Install bolts (81). Use Tooling (C) to tighten bolts (81) to a torque of 620 N·m (460 lb ft).



Illustration 33

g02033893

25. Install retaining ring (80).



Illustration 34

g02033195

26. Install impeller (79) and retaining ring (78).
-

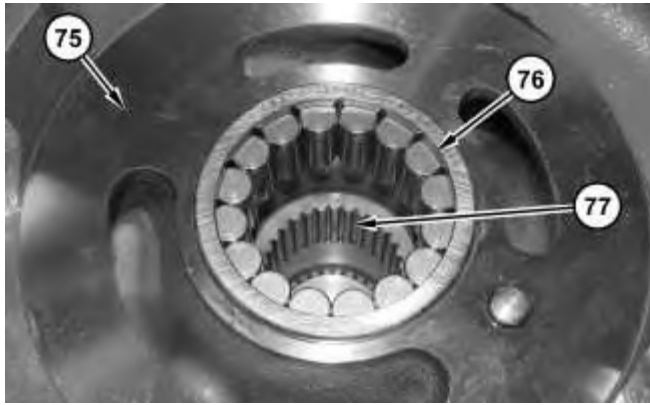


Illustration 35

g02033192

27. Install coupler (77). Install block (75) and bearing (76).

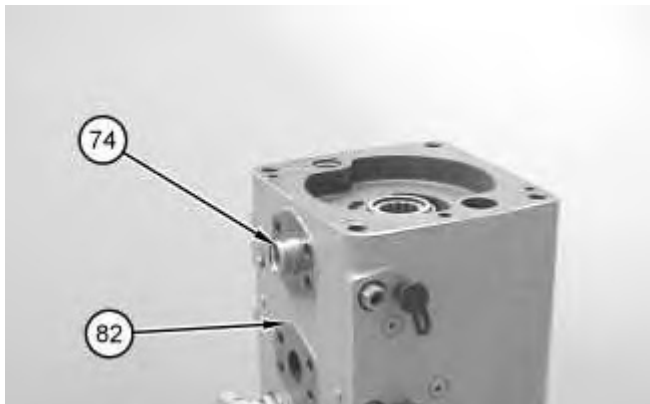


Illustration 36

g02054033

28. Use Tooling (N) to install bushing (74) into housing (82).

Note: The following assembly procedure is for the input shaft pump.

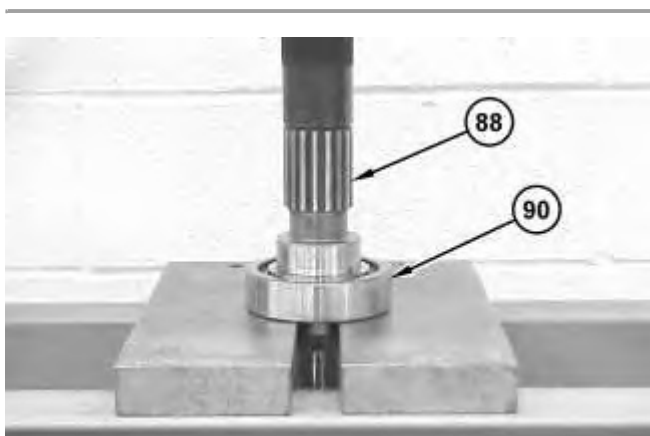


Illustration 37

g02034136

29. Use a suitable press and install shaft (88) into bearing (90).



Illustration 38

g02034140

30. Install retaining ring (89).

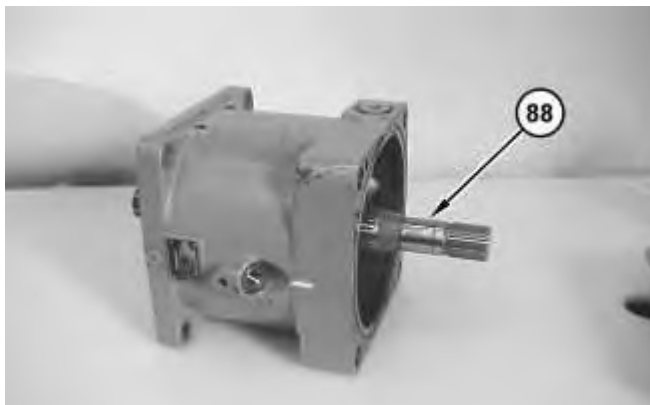


Illustration 39

g02034141

31. Use a soft faced hammer to install shaft assembly (88).



Illustration 40

g01098450

32. Install seal (69). Install O-ring seals (70) onto seal carrier (68).

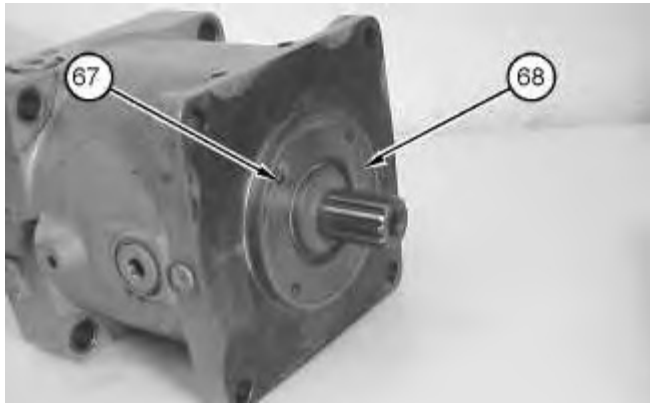


Illustration 41

g01098449

33. Install seal carrier (68). Install bolts (67).

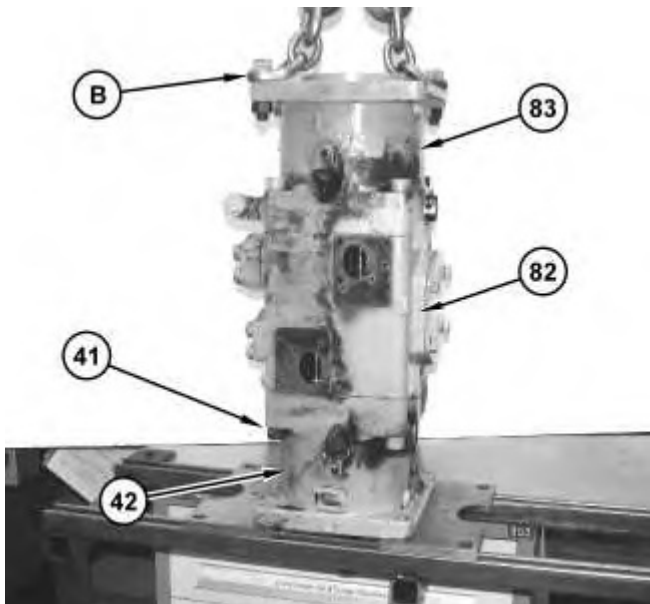


Illustration 42

g02019473



Improper assembly of parts that are spring loaded can cause bodily injury.

To prevent possible injury, follow the established assembly procedure and wear protective equipment.

34. Secure pump housing (42) to Tooling (A) or a suitable bench. Use Tooling (B) and a suitable lifting device to lower pump housing (83) and head (82) onto pump (42). The weight of pump (83) and head (82) is approximately 136 kg (300 lb).

35. Install bolts (41). Use Tooling (C) to tighten bolts (41) to a torque of 620 N·m (460 lb ft).

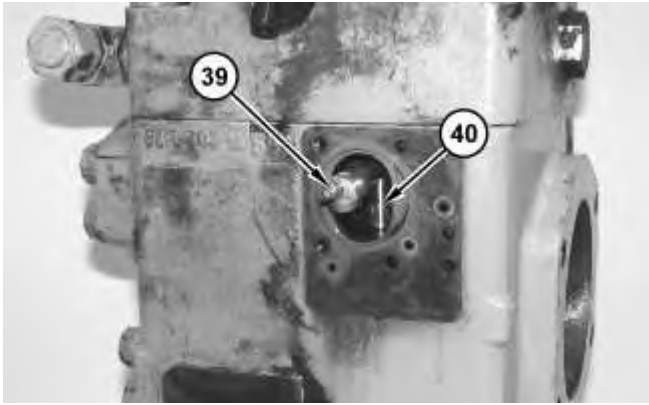


Illustration 43

g02019235

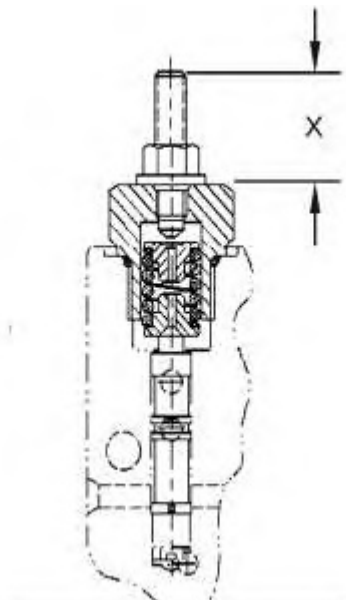
36. Install guide (39) into piston assembly (40).

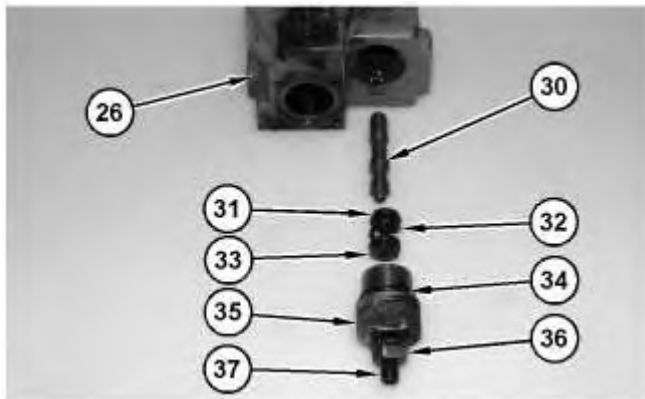


Illustration 44

g06193408

37. Install setscrew (20) and seal nut (38) onto valve (26).





 **WARNING**

Improper assembly of parts that are spring loaded can cause bodily injury.

To prevent possible injury, follow the established assembly procedure and wear protective equipment.

38. If necessary, Install setscrew (37) and seal nut (36) onto cap assembly (35).
39. Install O-ring seal (34) onto cap assembly (35).
40. Install spool (30), retainer (31), spring (32), and retainer (33) into valve (26).
41. Install cap assembly (35) onto valve (26). Tighten cap assembly (35) to a torque of 60 ± 4 N.m (44 ± 3 lb ft).
42. The following procedure is to be followed to set the Dimension (X):
 - If Dimension (X) is not measured during disassembly, maintain a Dimension (X) of 25 mm (1 inch).
 - If Dimension (X) is measured during disassembly, turn set screw (37) until Dimension (X) is achieved, in addition turn out set screw (37) 1/8 turn counterclockwise.

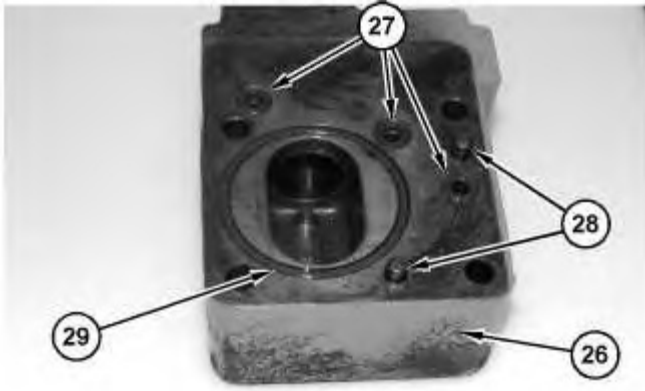


Illustration 47

g06193351

43. Install O-ring seals (27), pins (28), and O-ring seal (29) into valve (26).

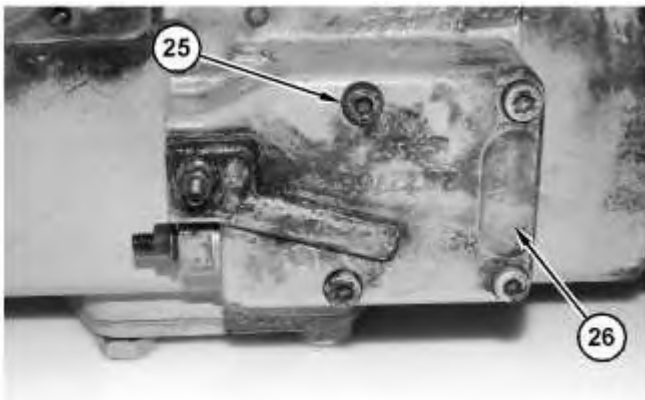


Illustration 48

g06193061

44. Install valve (26) and bolts (25).



Illustration 49

g06193059

45. Apply Tooling (M) and install spring (24) and spring guide (23) into the valve.



Suggest:

For more complete manuals. Please go to the home page.

<https://www.ebooklibonline.com>

If the above button click is invalid. Please download this document first, and then click the above link to download the complete manual.

Thank you so much for reading

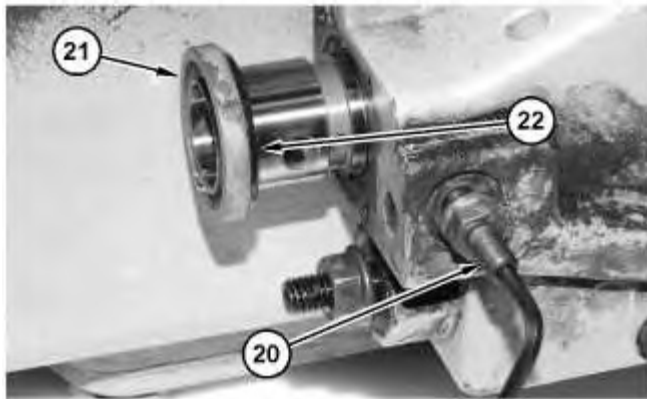


Illustration 50

g06193046

WARNING

Improper assembly of parts that are spring loaded can cause bodily injury.

To prevent possible injury, follow the established assembly procedure and wear protective equipment.

Note: Make sure that setscrew (20) aligns with the hole in bushing (21) during the installation.

46. Install O-ring seal (22) onto bushing (21).
47. Install bushing (21) into the valve.

Tighten setscrew (20) and the seal nut to the height recorded during the disassembly.

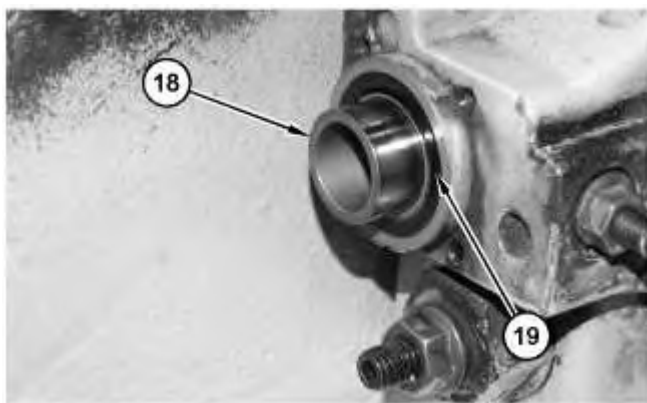


Illustration 51

g06193043

48. Install bushing (18) and O-ring seal (19).

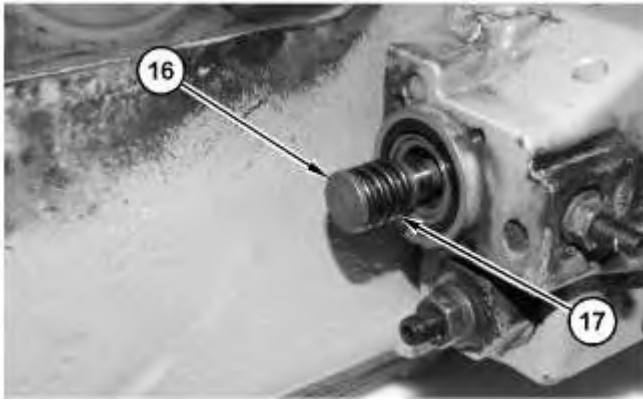


Illustration 52

g06193030

! WARNING

Improper assembly of parts that are spring loaded can cause bodily injury.

To prevent possible injury, follow the established assembly procedure and wear protective equipment.

49. Install spool (16) and spring (17).

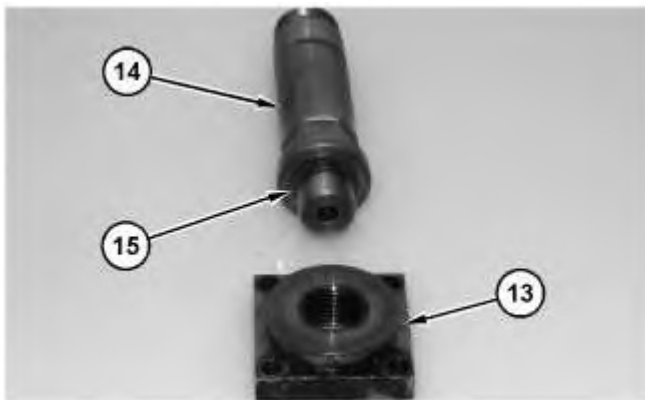


Illustration 53

g06193025

50. Install O-ring seal (15) onto adapter (14).

Install cartridge (14) into adapter (13).

<https://www.ebooklibonline.com>

Hello dear friend!

Thank you very much for reading.

Enter the link into your browser.

The full manual is available for immediate download.

<https://www.ebooklibonline.com>