

Product: TRUCK

Model: 793F TRUCK D3T

Configuration: 793F OFF-HIGHWAY TRUCK D3T00001-UP (MACHINE) POWERED BY C175 ENGINE

Disassembly and Assembly 793F Off-Highway Truck Machine Systems

Media Number -KENR8579-09

Publication Date -01/10/2018

Date Updated -01/10/2018

i03668340

Service and Parking Brake (Front) - Disassemble

SMCS - 4251-015; 4267-015

Disassembly Procedure

Table 1

Required Tools			
Tool	Part Number	Part Description	Qty
A	138-7576	Link Bracket	2
B	-	(3/8 - 16) NC by 4 inch Forcing Bolt	2
C	4C-8358	Eyebolt	2
D	FT-0841	Spring Compressor	1

Start By:

- a. Remove the front service and parking brake.

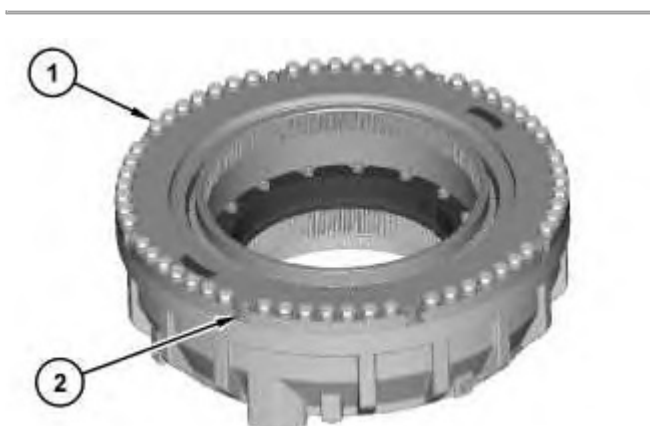

WARNING

Personal injury can result from being struck by parts propelled by a released spring force.

Make sure to wear all necessary protective equipment.

Follow the recommended procedure and use all recommended tooling to release the spring force.

1. Remove bolts (1). Loosen nuts (2) by one half turn at a time until the spring tension has been released.
2. Remove nuts (2).

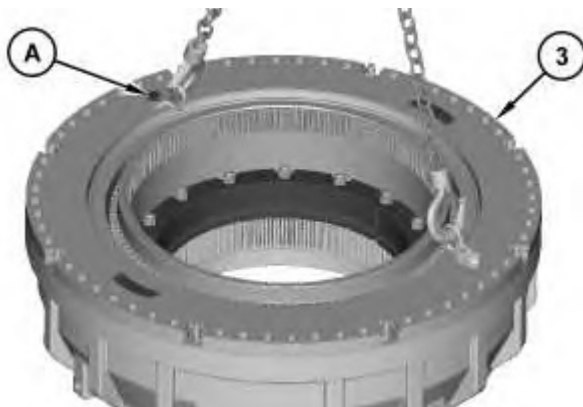

3. Use Tooling (A) in order to remove plate (3). The weight of plate (3) is approximately 113 kg (250 lb).



4. Remove damper assembly (4).

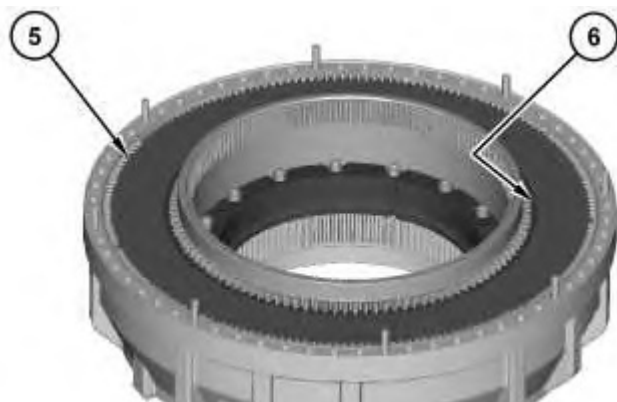

Illustration 4

5. Remove plates (5) and discs (6).

Note: Note the quantity and the order of plates (5) and discs (6) for installation purposes.

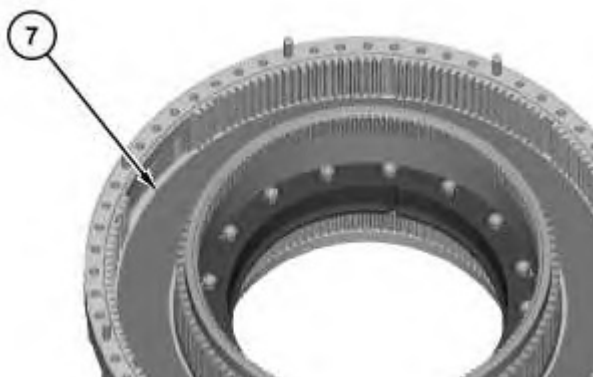
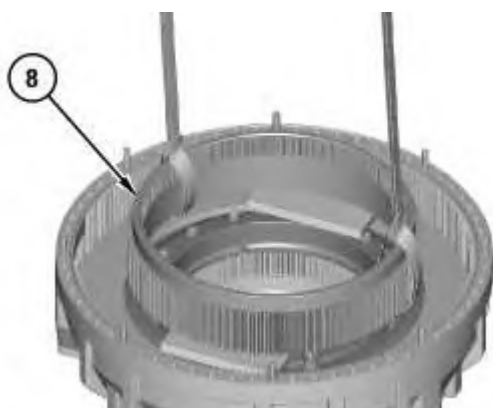

Illustration 5

6. Remove damper assembly (7).



<https://www.ebooklibonline.com>

Hello dear friend!

Thank you very much for reading.

Enter the link into your browser.

The full manual is available for immediate download.

<https://www.ebooklibonline.com>

7. Use a suitable pry bar in order to raise brake hub (8). Install suitable blocking and attach a suitable lifting device onto brake hub (8). The weight of brake hub (8) is approximately 68 kg (150 lb). Remove brake hub (8).

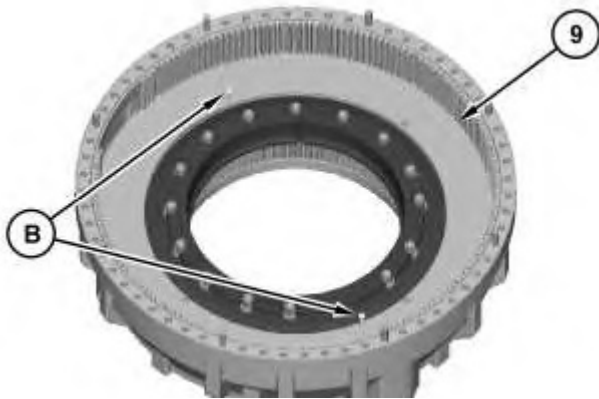

Illustration 7

8. Install Tooling (B) into piston (9). Tighten Tooling (B) evenly in order to compress the guide springs.

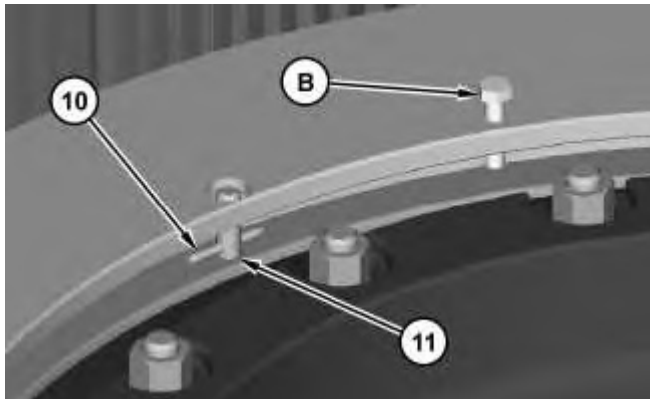

Illustration 8

9. Install pin (10) into guide (11). Repeat this step for the remaining guides (11).
 10. Remove Tooling (B).
-

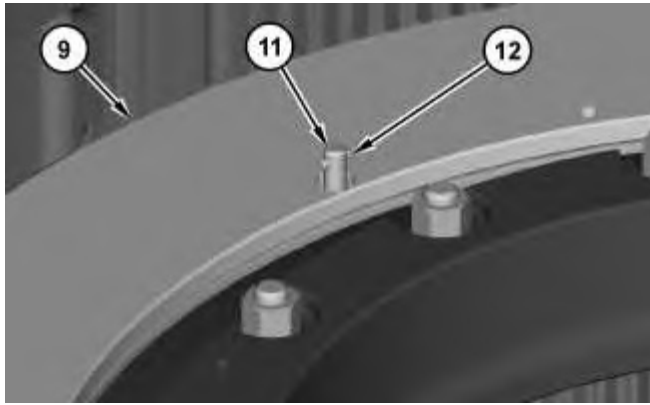

Illustration 9

g01423682

11. Press down piston (9). Remove pin (12) from guide (11).

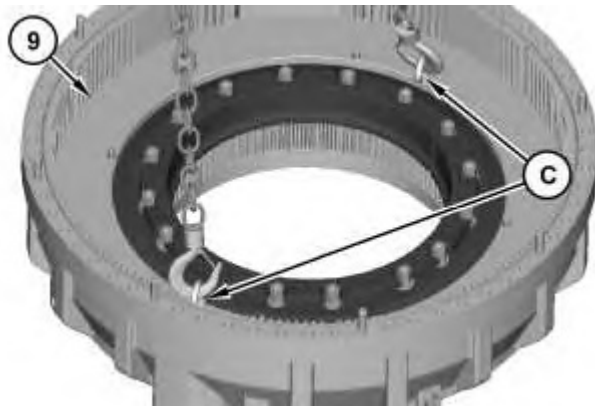

Illustration 10

g01423689

12. Use Tooling (C) and a suitable lifting device in order to remove piston (9). The weight of piston (9) is approximately 86 kg (190 lb).

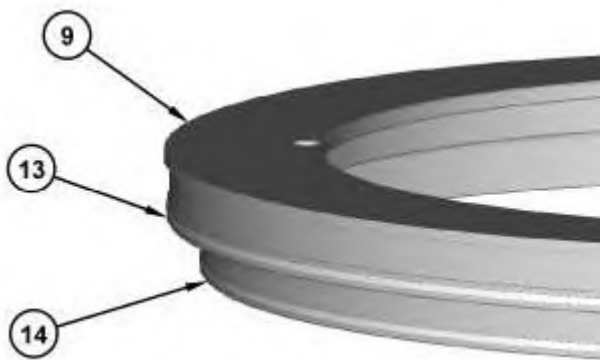

Illustration 11

g01423817

13. Remove the outer seal rings and the inner seal rings (13). Remove the outer seal rings and the inner seal rings (14) from piston (9).

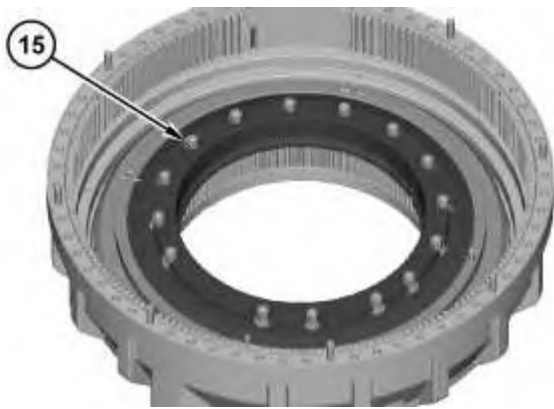

Illustration 12

g01423822

! WARNING

Personal injury can result from being struck by parts propelled by a released spring force.

Make sure to wear all necessary protective equipment.

Follow the recommended procedure and use all recommended tooling to release the spring force.

14. Loosen nuts (15) by one-half turn at a time until the spring tension has been released.
15. Remove nuts (15).



Illustration 13

g01423826

16. Use Tooling (C) and a suitable lifting device in order to remove piston (16) and housing (17). The weight of piston (16) and housing (17) is approximately 132 kg (291 lb).
17. Separate housing (17) from piston (16).

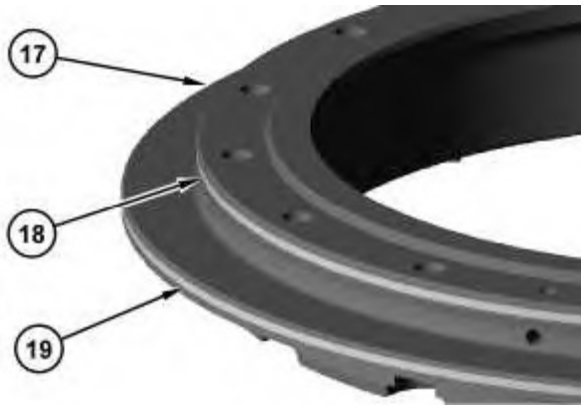

Illustration 14

g01423830

18. Remove the outer seal rings and the inner seal rings (18). Remove the outer seal rings and the inner seal rings (19) from housing (17).



Illustration 15

g01423843

19. Remove seals (20) from housing (17).

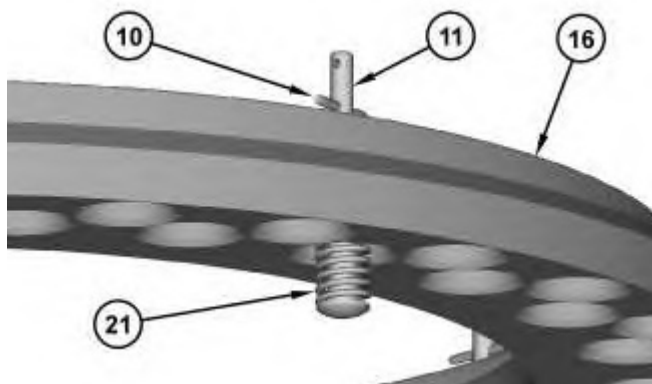

Illustration 16

g01423853

 **WARNING**

Personal injury can result from being struck by parts propelled by a released spring force.

Make sure to wear all necessary protective equipment.

Follow the recommended procedure and use all recommended tooling to release the spring force.

20. Use Tooling (D) in order to compress guide spring (21). Remove pin (10), guide (11), and guide spring (21) from piston (16). Repeat this step for the remaining pins (10), guides (11), and guide springs (21).
-

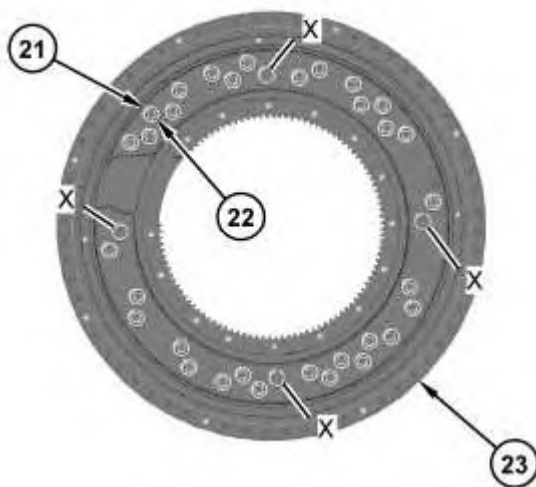

Illustration 17

g01423869

21. Note the location of the springs that are marked with an X. Remove springs (21) and inner springs (22) from anchor (23).
-

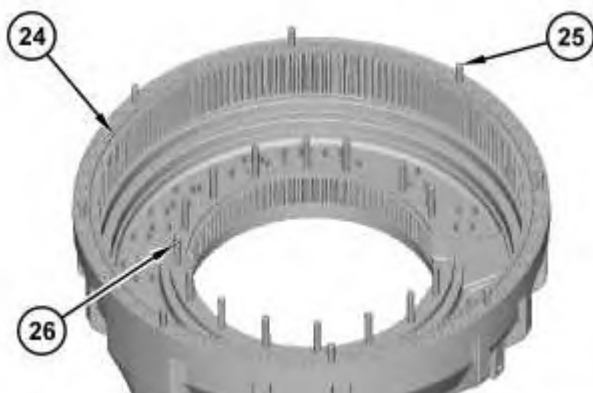

Illustration 18

g01423880

22. Remove O-ring seal (24). Remove studs (25) and studs (26), if necessary.

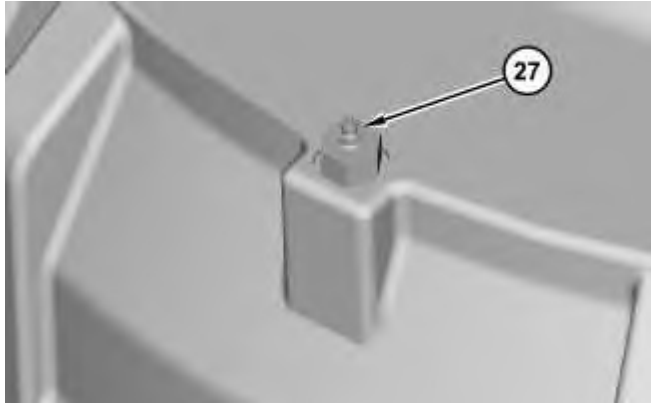

Illustration 19

g01423885

23. Remove purge screw (27) and the adapter.

Product: TRUCK

Model: 793F TRUCK D3T

Configuration: 793F OFF-HIGHWAY TRUCK D3T00001-UP (MACHINE) POWERED BY C175 ENGINE

Disassembly and Assembly 793F Off-Highway Truck Machine Systems

Media Number -KENR8579-09

Publication Date -01/10/2018

Date Updated -01/10/2018

i02625657

Service and Parking Brake (Front) - Assemble - Standard Wheel

SMCS - 4251-016; 4267-016

S/N - D3T1-UP

S/N - SSP1-UP

S/N - SXP1-UP

Assembly Procedure

Table 1

Required Tools			
Tool	Part Number	Part Description	Qty
A	1P-7405	Eye Bolt	2
B	FT-0841	Spring Compressor	1
C	138-7576	Link Bracket	2
D		(3/8 - 16) NC by 4 inch Forcing Screw	2

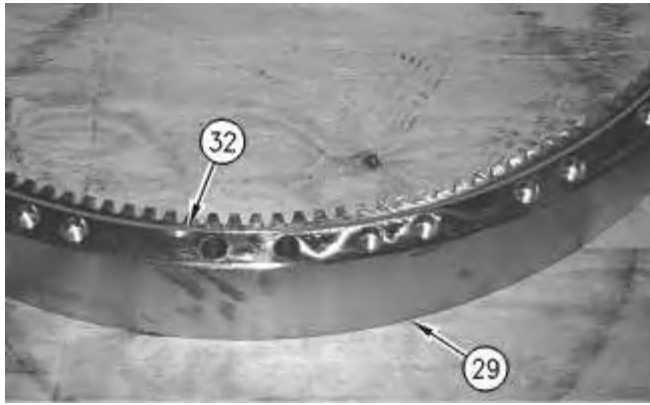

Illustration 1

g00440250

1. Install O-ring seal (32) on ring (29).

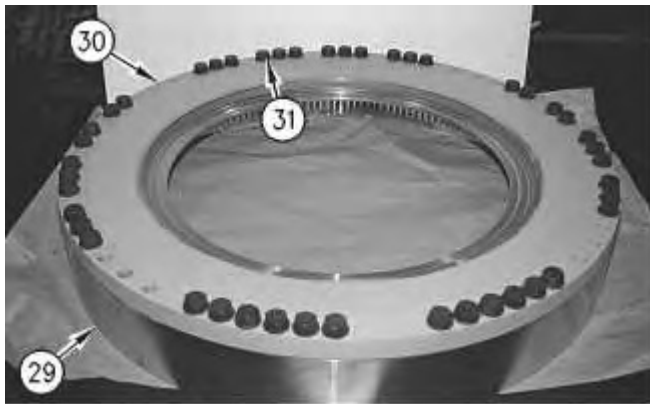

Illustration 2

g00440249

2. Turn over ring (29) and plate (30). The weight of ring (29) and plate (30) is approximately 200 kg (441 lb). Install plate (30) and bolts (31) on ring (29). The weight of plate (30) is approximately 110 kg (243 lb). Tighten bolts (31) to a torque of 500 ± 50 N·m (369 ± 37 lb ft).

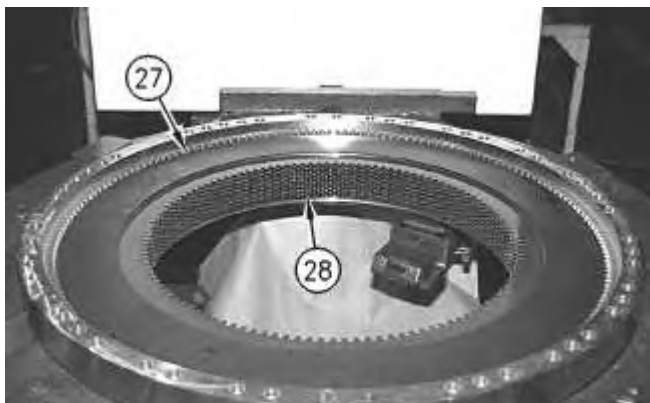

Illustration 3

g00440247

3. Install friction discs and plates (28). Install dampers (27).

Note: The order for the installation is a damper, a friction disc, and a plate. Then, install friction discs and plates in an alternating order. End the installation with a damper.

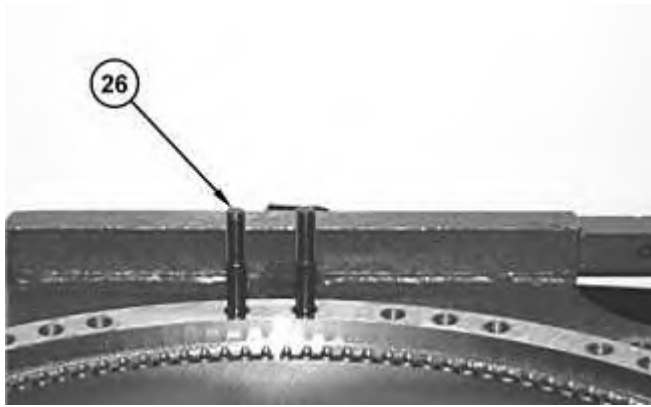

Illustration 4

g01317883

4. Install studs (26). Tighten studs (26) to a torque of $100 \pm 15 \text{ N}\cdot\text{m}$ ($74 \pm 11 \text{ lb ft}$).

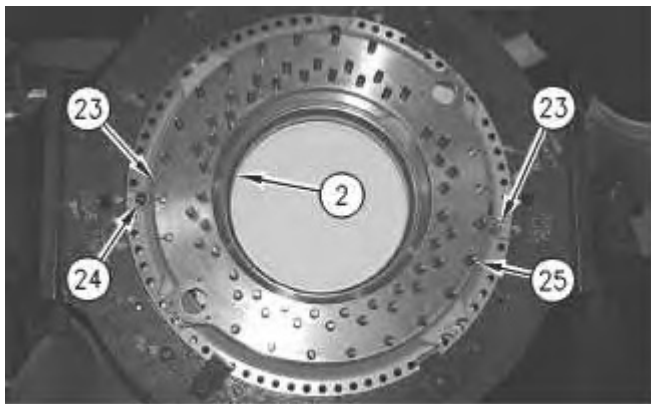

Illustration 5

g00439827

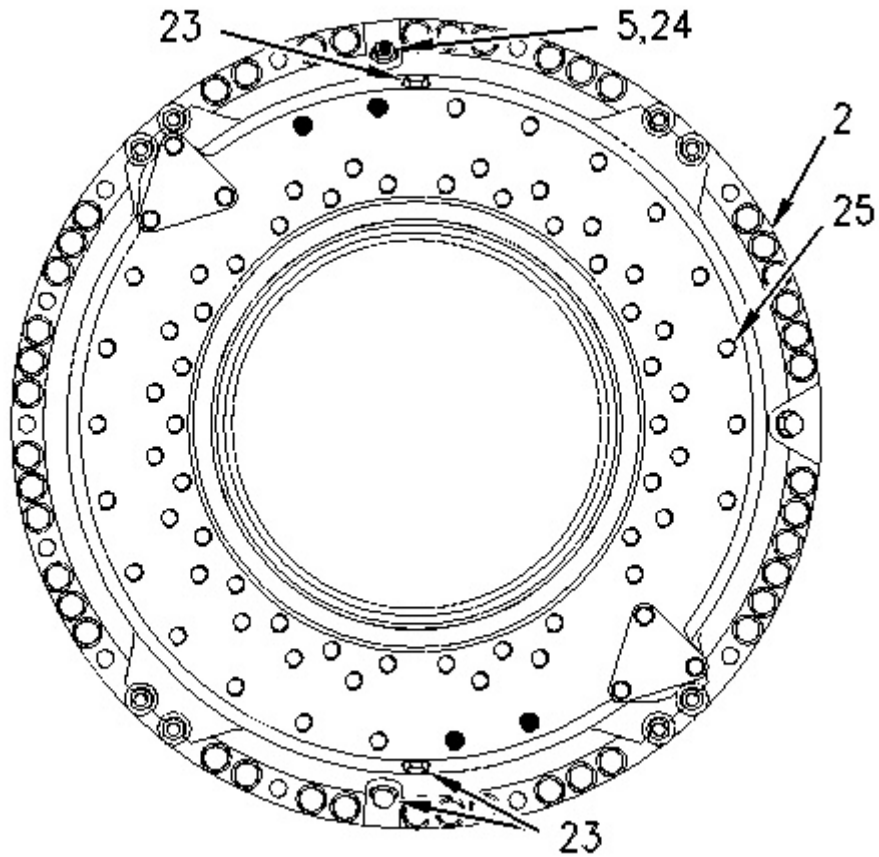

Illustration 6

g00440243

5. Install studs (25) on anchor (2). Tighten studs (25) to a torque of $230 \pm 30 \text{ N}\cdot\text{m}$ ($170 \pm 22 \text{ lb ft}$).

Note: Do not install studs in the shaded areas on the illustration.

6. Install the O-ring seals and plugs (23). Install adapter (24) and purge screw (5) on anchor (2).

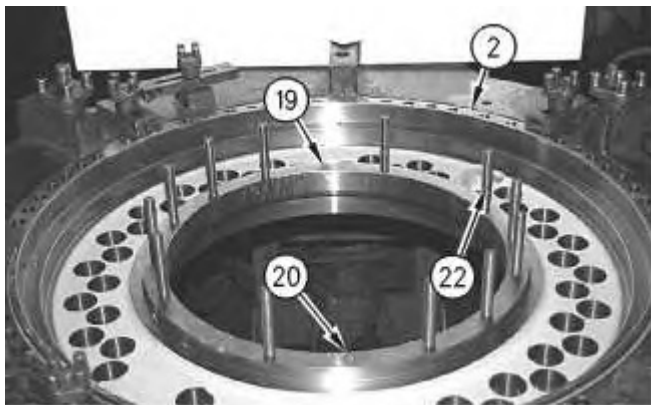

Illustration 7

g00439683

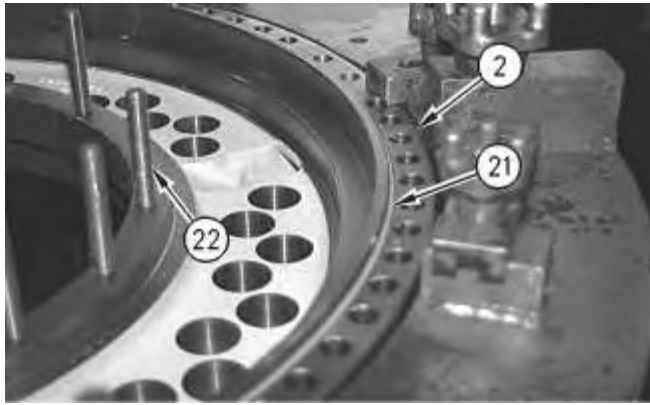

Illustration 8

g00439703

7. Install studs (22) on anchor (2).
8. Install O-ring seal (19), O-ring seal (20), and O-ring seal (21) on anchor (2).

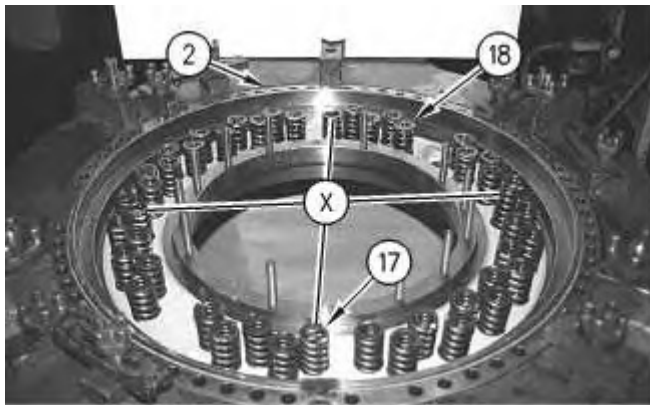

Illustration 9

g00439663

Note: There are four springs (17) at Location (X) that do not have inner springs (18).

9. Install inner springs (18) and springs (17) on anchor (2).

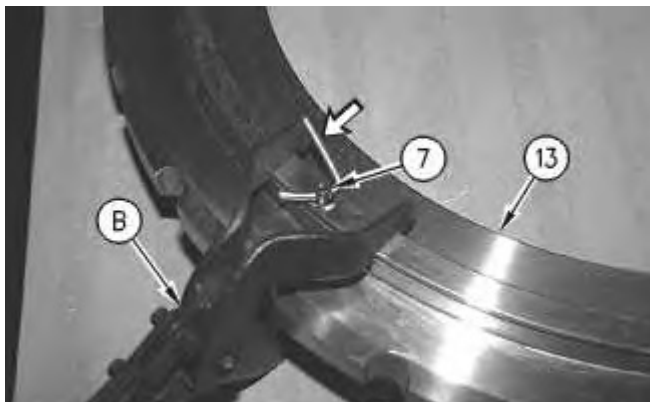

Illustration 10

g00439623

WARNING

Improper assembly of parts that are spring loaded can cause bodily injury.

To prevent possible injury, follow the established assembly procedure and wear protective equipment.

10. Use Tooling (B) to compress the guide spring. Install the guide spring, guide (7), and pin (6) on piston (13). Repeat this procedure for the remaining guide springs, guides (7), and pins (6).

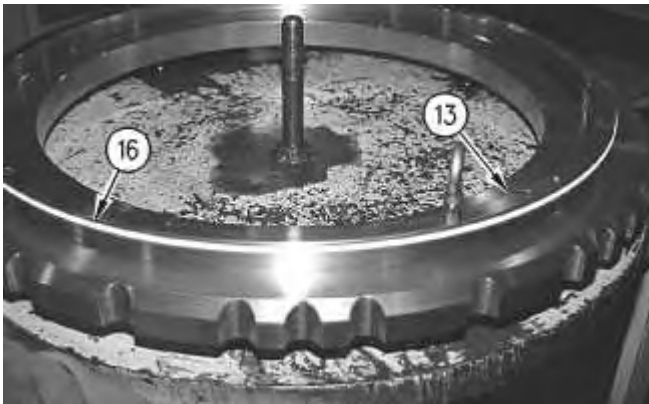

Illustration 11

g00439583

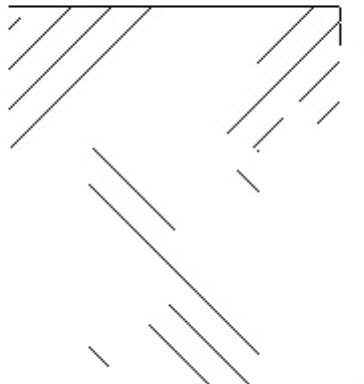

Illustration 12

Correct installation of the seal rings

g01317692

11. Install seal ring (16) on piston (13).

Note: Seal rings (16) must be installed with the yellow side facing outward.

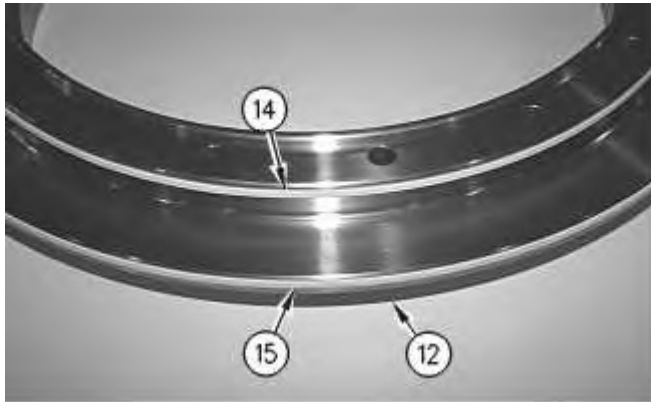

Illustration 13

g00439495

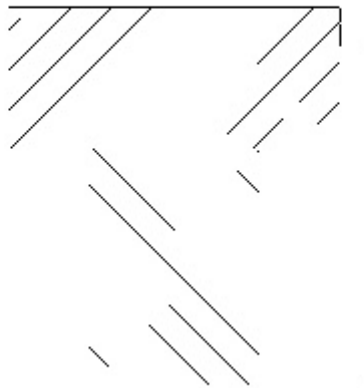

Illustration 14

g01317692

Correct installation of the seal rings

12. Install seal rings (15) and seal rings (14) on housing (12).

Note: Seal rings (15) and seal rings (14) must be installed with the yellow side facing outward.

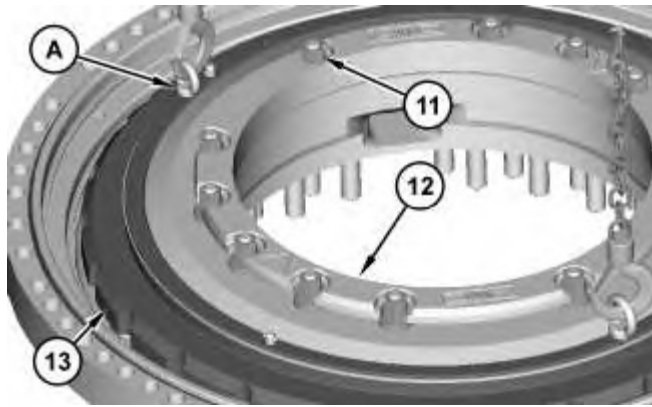

Illustration 15

g01316339

 **WARNING**

Improper assembly of parts that are spring loaded can cause bodily injury.

To prevent possible injury, follow the established assembly procedure and wear protective equipment.

13. Install piston (13) onto housing (12).
14. Install nuts (11) on housing (12). Use individual turns to tighten the nuts. This will draw the housing downward evenly. After the nuts have bottomed out, tighten the nuts in a crisscross pattern to a torque of 270 ± 25 N·m (200 ± 18 lb ft).
15. Use Tooling (A) and a suitable lifting device in order to install housing (12) and piston (13) as a unit. The combined weight of piston (13) and housing (12) is approximately 112 kg (247 lb).



Illustration 16

g00439491

16. Tighten nuts (11).

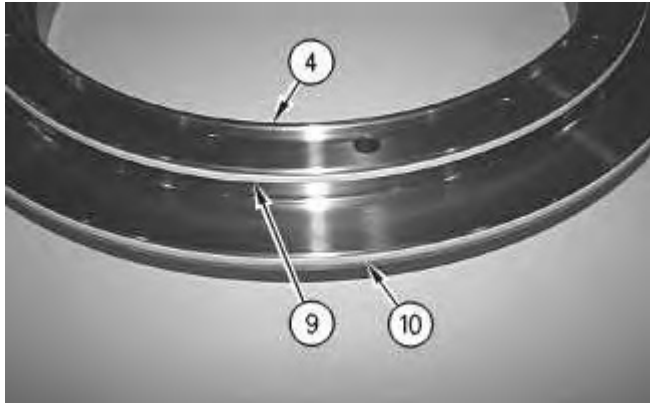

Illustration 17

g00439483

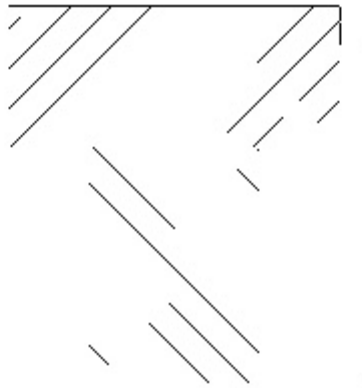

Illustration 18

g01317692

Correct installation of the seal rings

17. Install seal rings (10) and seal rings (9) on piston (4).

Note: Seal rings (10) and seal rings (9) must be installed with the yellow side facing outward.

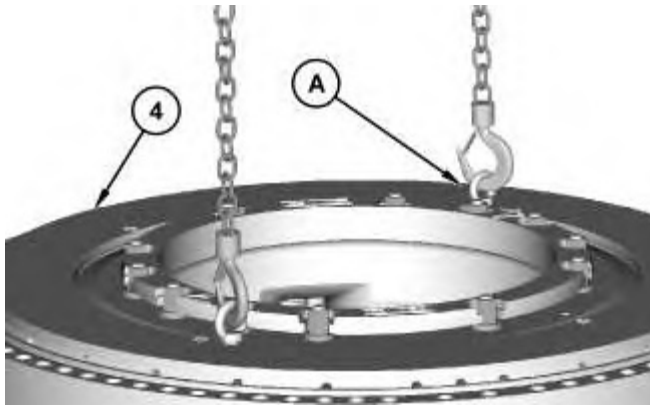

Illustration 19

g01316325

18. Use Tooling (A) and a suitable lifting device to install piston (4). The weight of piston (4) is approximately 83 kg (183 lb).

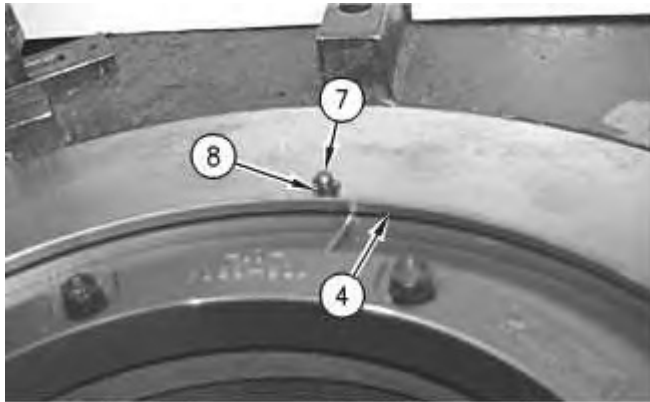

Illustration 20

g00439436

19. Press down piston (4). Install pins (8) on guides (7).

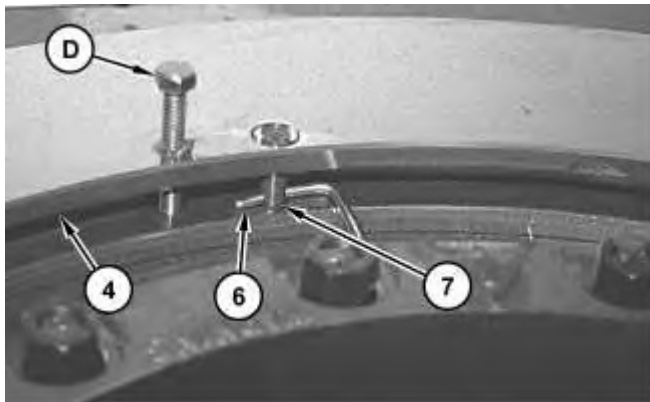

Illustration 21

g01317220

20. Install Tooling (D) in piston (4).
21. Remove pins (6) from guides (7).



Suggest:

For more complete manuals. Please go to the home page.

<https://www.ebooklibonline.com>

If the above button click is invalid. Please download this document first, and then click the above link to download the complete manual.

Thank you so much for reading

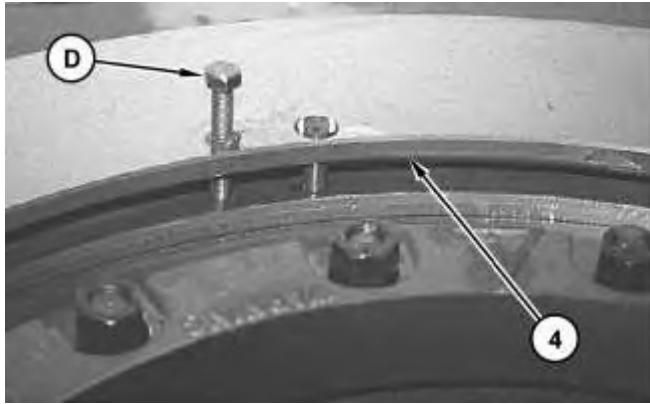

Illustration 22

g01317209

22. Remove Tooling (D) from piston (4).

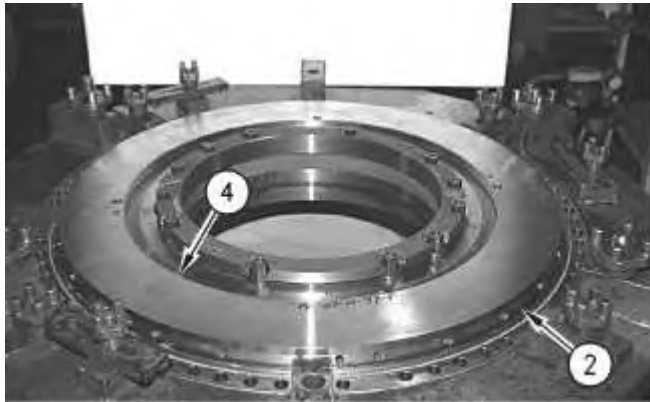

Illustration 23

g00439431

23. Turn over anchor (2). Piston (4) should be facing downward.

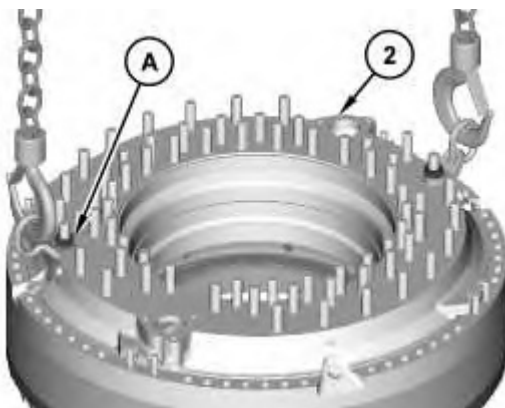

Illustration 24

g01316313

24. Use a suitable lifting device to install anchor (2) on the brake assembly. The weight of anchor (2) is approximately 206 kg (454 lb).

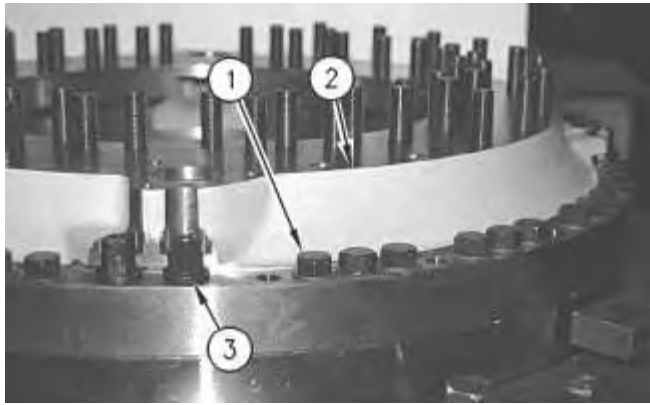

Illustration 25

g00439427

25. Install nuts (3) onto anchor (2). Tighten nuts (3). Use individual turns to tighten the nuts. This will draw the housing downward evenly. After the nuts have bottomed out, tighten the nuts in a crisscross pattern to a torque of 270 ± 25 N·m (200 ± 18 lb ft).
26. Install bolts (1) onto anchor (2).

End By:

- a. Install the front service and parking brake. Refer to Disassembly and Assembly, "Service and Parking Brake (Front) - Install".

<https://www.ebooklibonline.com>

Hello dear friend!

Thank you very much for reading.

Enter the link into your browser.

The full manual is available for immediate download.

<https://www.ebooklibonline.com>