

Product: TRUCK

Model: 793 TRUCK 3SJ

Configuration: 793 TRUCK 3SJ00001-UP (MACHINE) POWERED BY 3516 ENGINE

## Disassembly and Assembly 793 TRUCK VEHICLE SYSTEMS

Media Number -SEN4917-00

Publication Date -01/04/1991

Date Updated -19/05/2017

SEN49170004

### Hoist Cylinders

SMCS - 5102-010; 5102-015; 5102-016

### Remove And Install Hoist Cylinders

Tools Needed		A	B
1P820	Hydraulic Puller Group	1	
8S6586	Forcing Screw	1	
6V9061	Manual Pump Group (or electric)	1	
5B637	Nut	1	
5P8677	Adapter	1	
5F7353	Washer	1	
8B7549	Leg	2	
3H465	Plate	4	
1B4207	Nut	2	
FT958	Lifting Arm		1

1. Drain the oil from the hydraulic tank.



**WARNING**

**Make sure all the pressure in the hydraulic system has been released before disconnecting any oil lines.**

---

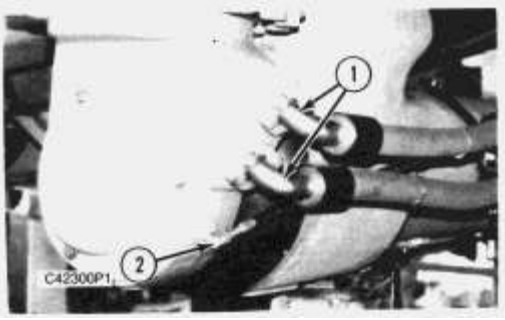

2. Disconnect oil lines (1) from the bottom of the hoist cylinder.

3. Disconnect lubrication line (2) from the hoist cylinder.

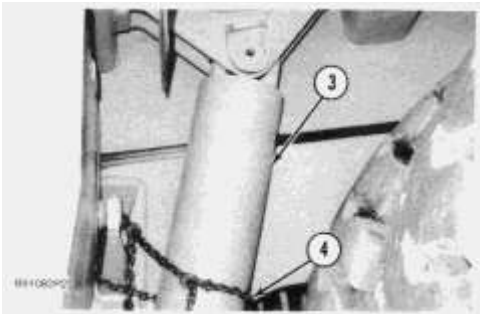

4. Fasten chain (4) to hoist cylinder (3) to support the cylinder when the top pin is removed.

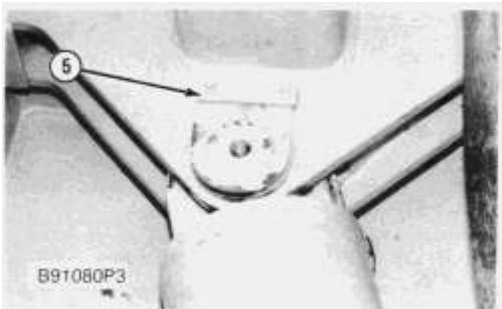

5. Remove the bolts and bar (5) that hold the top pin in place.

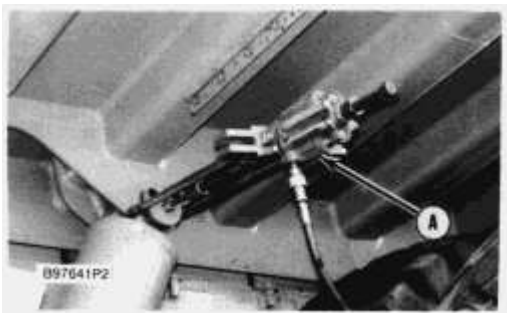

6. Remove the top pin with tooling (A). Remove the two spacers.

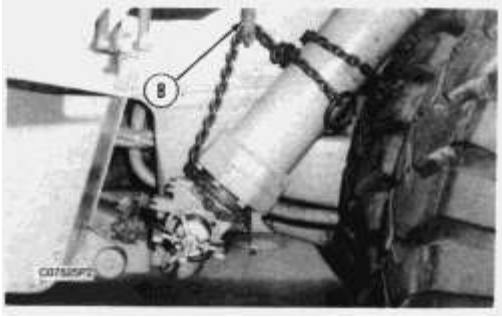

Typical Example

7. Install tool (B) on the bucket of a wheel loader or a suitable hoist.
8. Put tape on the hoist cylinder rod for protection when tool (B) is installed. If a nylon strap is used, the tape is not necessary.
9. Fasten a chain or nylon strap and tool (B) to hoist cylinder (3). Support the weight of the hoist cylinder with tool (B).

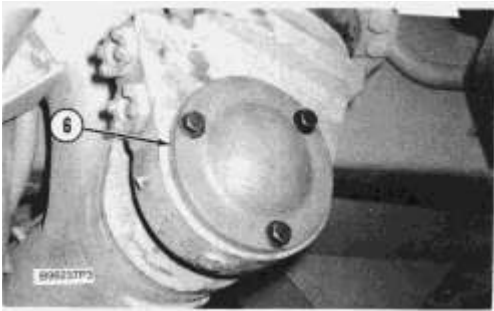

10. Remove the bolts and cover (6) from the lower hoist cylinder pin.

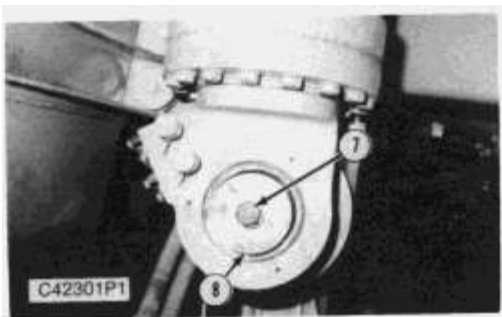

11. Remove bolt (7) and plate (8). Remove hoist cylinder (3) from the machine. The weight of the hoist cylinder is **2295 kg (4620 lb)**.

**NOTE:** The following steps are for the installation of the hoist cylinders.

12. Install tool (B) on the bucket of a wheel loader.
13. Fasten tool (B) to a hoist cylinder (3). Put the hoist cylinder in position on the bottom pin.
14. Install plate (8) with bolt (7).
15. Install cover (6) with three bolts.

**<https://www.ebooklibonline.com>**

Hello dear friend!

Thank you very much for reading.

Enter the link into your browser.

The full manual is available for immediate download.

**<https://www.ebooklibonline.com>**

16. Align the end of the hoist cylinder with the pin boss in the truck body, and install the top pin with the two spacers.
17. Install bar (5) and the bolts to hold the pin in place.
18. Connect oil lines (1) to the bottom of the hoist cylinder.
19. Connect lubrication line (2).
20. Fill the hydraulic tank with oil to the correct level. See the Maintenance Manual.

## Disassemble Hoist Cylinders

**NOTE:** Photos are from a 785 Truck. Procedures are the same for a 793 Truck.

Tools Needed		A	B
6V4947	Hydraulic Cylinder Repair Stand	1	
3S6224	Hydraulic Pump Assembly	1	
5P9736	Link Bracket		2

Start By:

- a. remove hoist cylinders

**NOTE:** Make sure all of the oil is removed from the cylinder before it is disassembled.

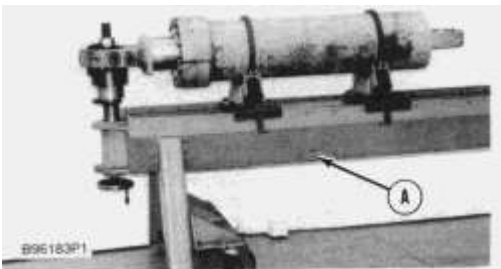

1. Put the hoist cylinder in position on tooling (A) as shown.

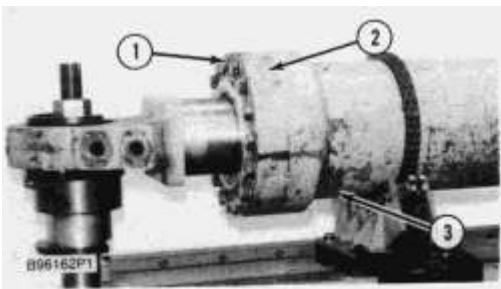

2. Remove bolts (1) and the washers. Use tool (A), and pull cylinder assembly (3) away from head (2).

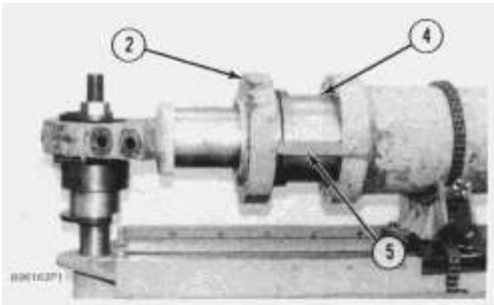

3. Put two wood blocks (5) **152.4 mm (6.00 in)** long between the cylinder assembly and head (2) as shown. Use tooling (A) to push head (2) off of cylinder (4).

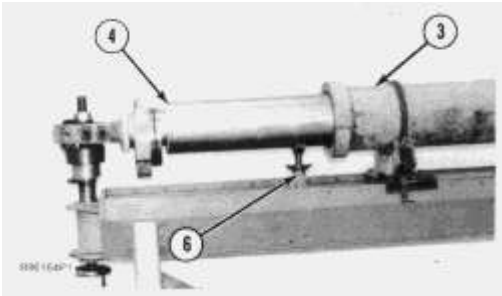

4. Use tooling (A), and pull cylinder assembly (3) part way off of cylinder (4).

5. Put support (6) in position under cylinder (4). Remove cylinder assembly (3) the rest of the way.

6. Fasten a hoist to cylinder assembly (3), and remove it from tooling (A). The weight of the cylinder assembly is **approximately 238 kg (495 lb)**.

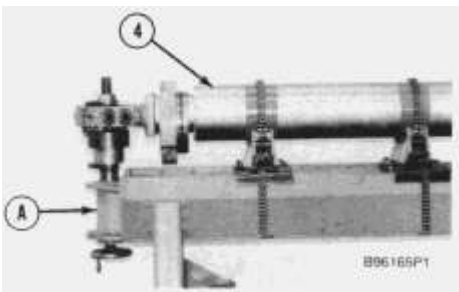

7. Put tape around cylinder (4) to protect the cylinder when it is fastened to tooling (A).

8. Fasten cylinder (4) to tooling (A) as shown.

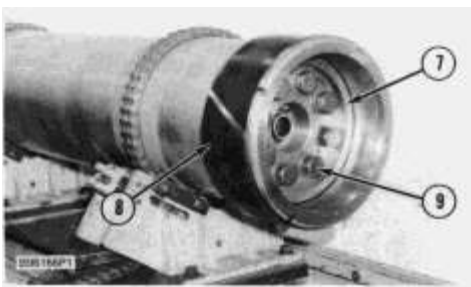

9. Remove ring (8) from the cylinder.

10. Remove bolts (9) that hold piston (7) to the rod assembly.

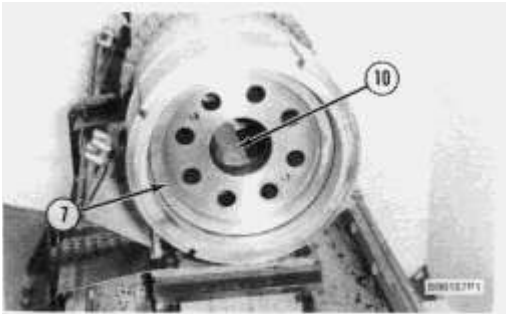

11. Use tooling (A), and pull the rod assembly part way out of the cylinder.

12. Put two wood blocks (10) in position between the rod assembly and piston (7) as shown. Use tooling (A), and push the piston out of the cylinder.

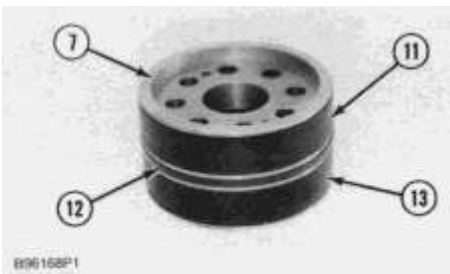

13. Remove rings (11) and (13) and seal assembly (12) from piston (7).

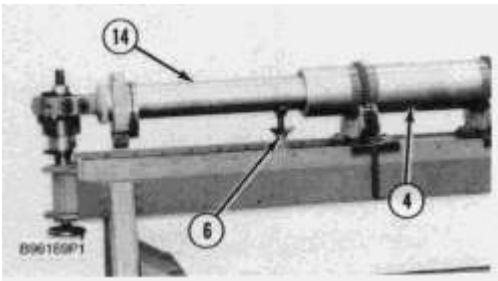

14. Use tooling (A) to pull cylinder (4) part way off of rod assembly (14). Put support (6) in position under rod assembly (14) as shown. Pull the cylinder off of the rod assembly.

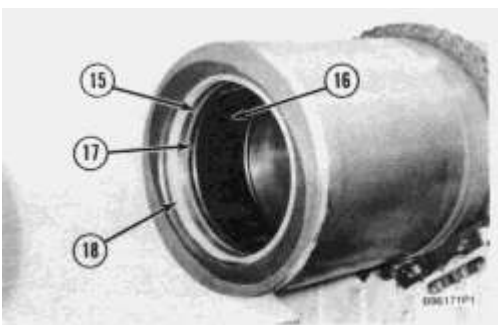

15. Remove wiper (18), seal (15), seal (17) and ring (16) from the cylinder.

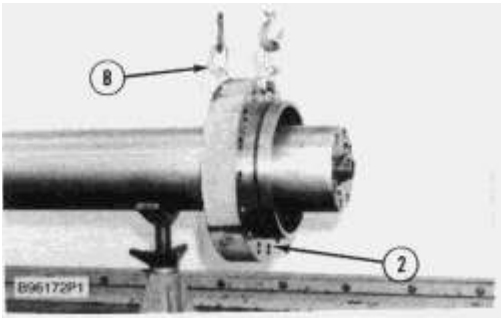

16. Fasten a hoist and tool (B) to head (2). Remove the head from the rod assembly. The weight of the head is **approximately 56 kg (123 lb)**.

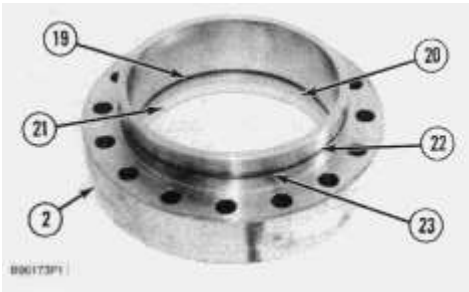

17. Remove O-ring seal (22) and ring (23) from the outside of head (2).

18. Remove seals (19) and (20) and wiper (21) from the inside of head (2).

## Assemble Hoist Cylinders

**NOTE:** Photos are of a 785 Truck. Procedures are the same for a 793 Truck.

Tools Needed		A	B
6V4947	Hydraulic Cylinder Repair Stand	1	
3S6224	Electric Hydraulic Pump	1	
5P9736	Link Bracket		2

**NOTE:** Put clean hydraulic oil on all O-ring seals, seals and wipers before they are installed. Also, put clean hydraulic oil on the rod assembly and cylinder.



1. Put seals (19) and (20) and wiper (21) in position in the inside of head (2). The thick seal (19) goes toward the inside (pressure side) of the head. The thin seal (20) goes to the outside (atmosphere side of the head). Install wiper (21) with the lip toward the outside.

2. Install O-ring seal (22) and back-up ring (23) on the outside of head (2). Install the O-ring seal toward the inside (pressure side) of the head.

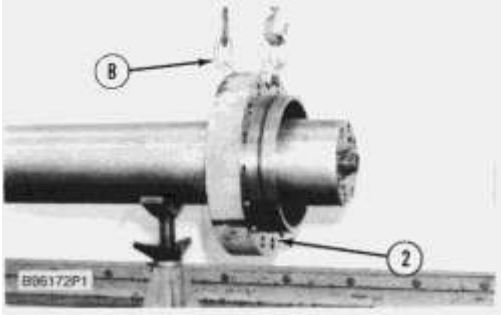

3. Fasten a hoist and tooling (B) to head (2). Put the head in position on the rod assembly as shown.

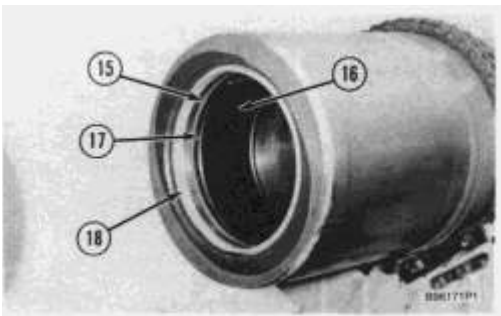

4. Install ring (16), seals (15) and (17) and wiper (18) in the grooves in the end of the cylinder. The thick seal (17) goes toward the inside of the cylinder. The thin seal (15) goes toward the outside of the cylinder. Install wiper (18) with the lip toward the outside of the cylinder.

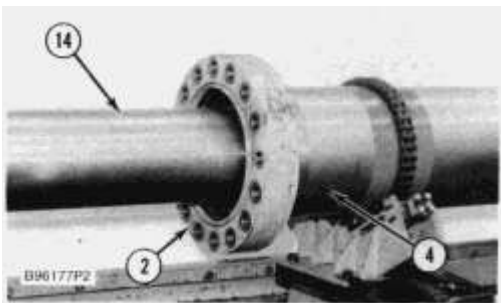

5. Put head (2) in position on cylinder (4).

6. Use tool (A) to push cylinder (4) on rod assembly (14).

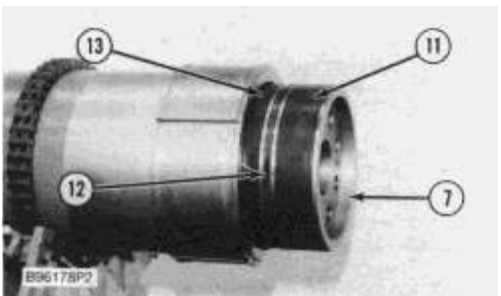

7. Put rings (13) and (11) and seal assembly (12) in position in the grooves in piston (7).

**NOTE:** Make sure the bolt holes in piston (7) are in alignment with the bolt holes in the rod assembly before it is installed.

**8.** Align the bolt holes in piston (7) with the bolt holes in the rod assembly, and put the piston in position in the end of the cylinder. Use a soft hammer, and carefully install the piston in the cylinder.

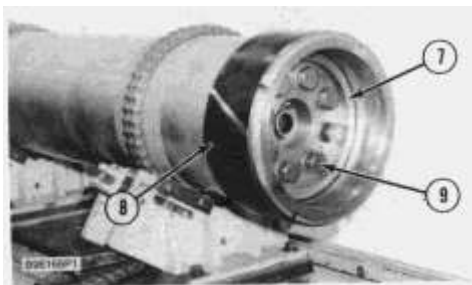

**9.** Install the washers and bolts (9) to hold piston (7) to the rod assembly.

**10.** Put ring (8) in position in the groove in the end of the cylinder.

**11.** Remove the support from under the rod assembly.

**12.** Remove the cylinder from the cradle on tooling (A), and install the support under the cylinder. Remove the tape from the cylinder.

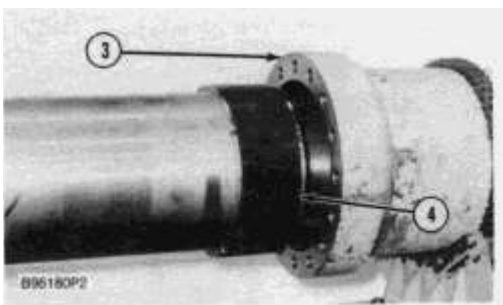

**13.** Fasten a hoist to cylinder assembly (3). Put the cylinder assembly in position on tooling (A).

**14.** Use tooling (A) to push cylinder assembly (3) on cylinder (4).

**NOTE:** The rod must be fully extended when the head bolts are tightened. This will keep the cylinders, piston and head in better alignment.

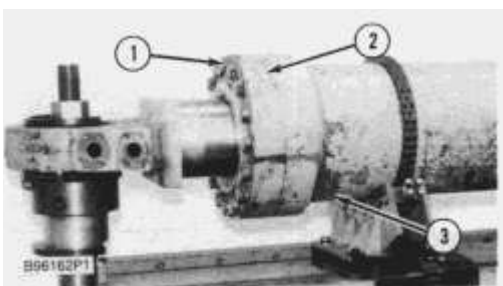

**15.** Align the bolt holes in head (2) with the bolt holes in cylinder assembly (3), and install the washers and bolts (1).

**16.** Retract the cylinder, and remove it from tooling (A).

End By:

**a.** install hoist cylinders

---

Product: TRUCK

Model: 793 TRUCK 3SJ

Configuration: 793 TRUCK 3SJ00001-UP (MACHINE) POWERED BY 3516 ENGINE

## Disassembly and Assembly 793 TRUCK VEHICLE SYSTEMS

Media Number -SEN4917-00

Publication Date -01/04/1991

Date Updated -19/05/2017

SEN49170005

# Hoist And Brake Cooling Pump

SMCS - 5083-010

## Remove And Install Hoist And Brake Cooling Pump

1. Raise the truck body, and install the body retaining cable.
2. Drain the oil from the hoist, converter and brake hydraulic tank.

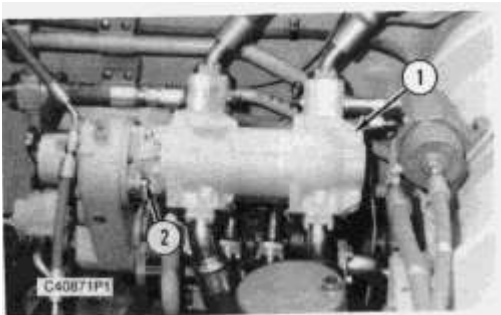

3. Disconnect the four hose assemblies from hoist and brake cooling pump (1).
4. Fasten a hoist to hoist and brake cooling pump (1). Remove four nuts (2), and remove the pump from the machine. The weight of the hoist and brake cooling pump is **50 kg (110 lb)**.

**NOTE:** The following steps are for installation of the hoist and brake cooling pump.

5. Make sure the O-ring seal is in position on the front of pump (1). Put pump (1) in position on the pump drive, and install four nuts (2).
6. Make sure the O-ring seals are in position in the end of the hose assemblies. Connect the hose assemblies to hoist and brake cooling pump (1).
7. Fill the hoist, converter and brake hydraulic tank with oil to the correct level. See the Maintenance Manual.
8. Remove the body retaining cable, and lower the truck body.

Product: TRUCK

Model: 793 TRUCK 3SJ

Configuration: 793 TRUCK 3SJ00001-UP (MACHINE) POWERED BY 3516 ENGINE

## Disassembly and Assembly 793 TRUCK VEHICLE SYSTEMS

Media Number -SEN4917-00

Publication Date -01/04/1991

Date Updated -19/05/2017

SEN49170006

# Hydraulic Tank

SMCS - 5056-010

## Remove And Install Hydraulic Tank

Tools Needed		A
5P9736	Link Bracket	1

1. Drain the oil from the hydraulic and transmission tank.

**NOTE:** Before disassembly, put identification marks on all hose assemblies and tube assemblies for correct assembly during installation.

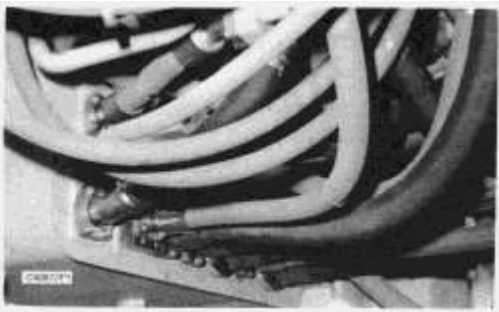

2. Disconnect twenty three hose assemblies from the inside of the hydraulic tank.

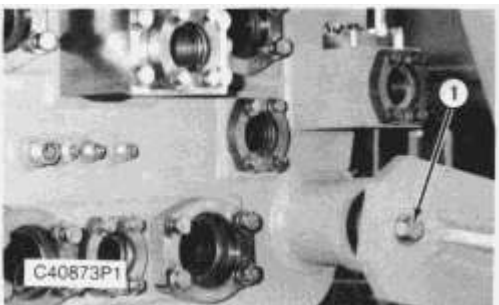

3. Remove bolt (1).

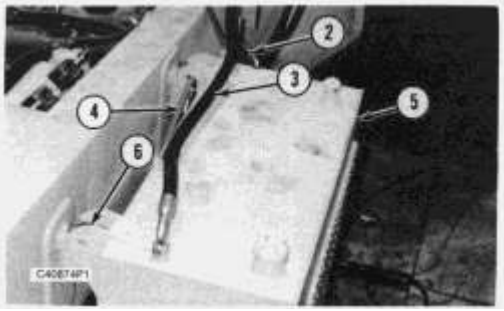

4. Disconnect hose assemblies (2), (3) and (4). Remove the mounting clips holding hose (3) to hydraulic tank (5).

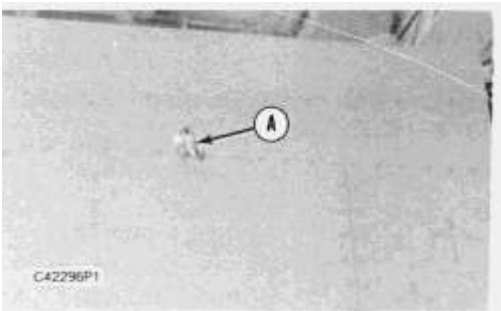

5. Attach tooling (A).

6. Fasten a hoist to the hydraulic tank.

---

### NOTICE

**Make sure all hose and tube assemblies have been disconnected before removing the hydraulic tank.**

---

7. Remove the bolts and two caps (6).

8. Remove the hydraulic tank. The weight of the hydraulic tank is **approximately 582 kg (1280 lb)**.

**NOTE:** The following steps are for installation of the hydraulic tank.

9. Fasten a hoist to the hydraulic tank, and put the hydraulic tank in position on the truck.

10. Install two caps (6) and the bolts. Remove the hoist from the hydraulic tank.

11. Connect hose assemblies (2), (3), and (4).

12. Install the mounting clips that hold hose (3) to hydraulic tank (5).

13. Install bolt (1).



**Suggest:**

**For more complete manuals. Please go to the home page.**

**<https://www.ebooklibonline.com>**

**If the above button click is invalid. Please download this document first, and then click the above link to download the complete manual.**

**Thank you so much for reading**

- 14.** Connect twenty three hose assemblies to the inside of the hydraulic tank.
  - 15.** Make sure all of the hose assemblies have been connected to the hydraulic tank.
  - 16.** Fill the hydraulic and transmission tank to the correct level. See the Maintenance Manual.
-

Product: TRUCK

Model: 793 TRUCK 3SJ

Configuration: 793 TRUCK 3SJ00001-UP (MACHINE) POWERED BY 3516 ENGINE

## Disassembly and Assembly 793 TRUCK VEHICLE SYSTEMS

Media Number -SEN4917-00

Publication Date -01/04/1991

Date Updated -19/05/2017

SEN49170007

# Steering Hydraulic Tank

SMCS - 4332-010

## Remove And Install Steering Hydraulic Tank

1. Drain the oil from the steering hydraulic tank.

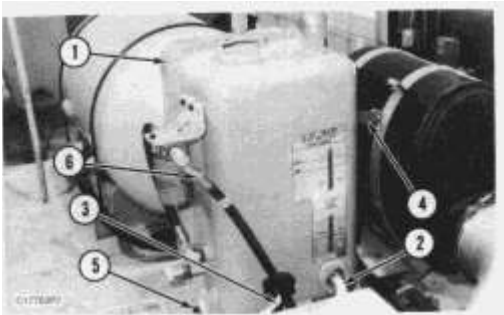

2. Disconnect hoses (2), (3) and (6) from the steering hydraulic tank.

3. Remove the bolt that holds bracket (4) to the steering hydraulic tank.

4. Fasten a hoist to steering hydraulic tank (1). Remove nine bolts (5) and the steering hydraulic tank from the platform. The weight of the steering hydraulic tank is **64 kg (142 lb)**.

**NOTE:** The following steps are for installation of the steering hydraulic tank.

5. Fasten a hoist to steering hydraulic tank (1). Put the tank in position on the platform, and install nine bolts (5).

6. Put bracket (4) in position on the steering hydraulic tank, and install the bolt that holds it in place.

7. Connect hoses (2), (3) and (6) to the steering hydraulic tank.

8. Fill the steering hydraulic tank with oil to the correct level. See the Maintenance Manual.

---

**<https://www.ebooklibonline.com>**

Hello dear friend!

Thank you very much for reading.

Enter the link into your browser.

The full manual is available for immediate download.

**<https://www.ebooklibonline.com>**