

Product: TRACTOR

Model: 784B TRACTOR 5RK

Configuration: 784B Tractor 5RK00001-UP (MACHINE) POWERED BY 3512 Engine

Disassembly and Assembly 785B TRUCK MACHINE SYSTEMS

Media Number -SEN5678-01

Publication Date -01/09/2004

Date Updated -17/10/2012

SEN56780012

Pump Drive

SMCS - 3108-015; 3108-016; 3108-010

Remove & Install Pump Drive

Tools Needed		A
5P9736	Link Bracket	1

Start By:

- a. remove steering pump
- b. remove hoist and brake cooling pump
- c. remove transmission pump *

*This operation is in the 785B Truck Power Train Disassembly And Assembly section.

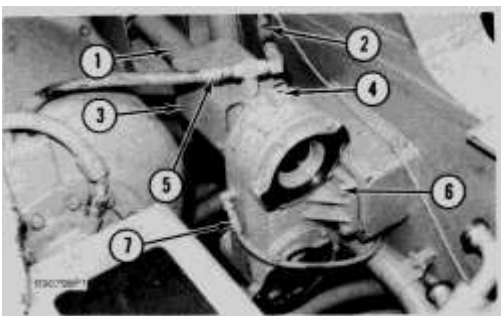

Typical Example

1. Disconnect hoses (2), (5) and (7) from the pump drive.
2. Remove the bolt at location (4). Move the clips and hose assemblies away from the pump drive.

3. Remove guard (3) from the pump drive. Remove the four bolts that hold hydraulic pump drive shaft (1) to the yoke assembly in the pump drive.
4. Install tool (A) at location (4), and fasten a hoist to it. The weight of the pump drive is **68 kg (150 lb)**.
5. Remove four bolts (6) and the pump drive.

NOTE: The following steps are for installation of the pump drive.

6. Put the pump drive in position with tool (A) and a hoist. Install bolts (6) that hold the pump drive in position. Remove tool (A).
7. Put hydraulic pump drive shaft (1) in position on the yoke assembly of the pump drive, and install the bolts that hold it. Tighten the bolts to a torque of **55 ± 7 N·m (41 ± 5 lb ft)**.
8. Put guard (3) in position, and install the bolts that hold it.
9. Connect hoses (2), (5) and (7).
10. Put the two hose assemblies and clips in position at location (4), and install the bolt that holds them in place.

End By:

- a. install transmission pump *
- b. install steering pump
- c. install hoist and brake cooling pump

*This operation is in the 785B Truck Power Train Disassembly And Assembly section.

Disassemble Pump Drive

Tools Needed		A	B
8B7549	Leg	2	
8B7548	Push-Puller	1	
8H684	Ratchet Box Wrench	1	
8H663	Bearing Pulling Attachment	1	
9S9154	Step Plate	1	
1P493	Drive Plate*		1
1P531	Handle*		1

*Part of 1P510 Driver Group.

Start By:

- a. remove pump drive

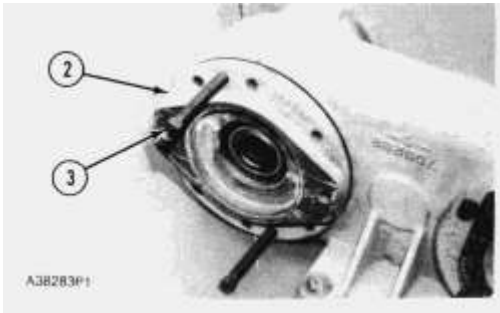
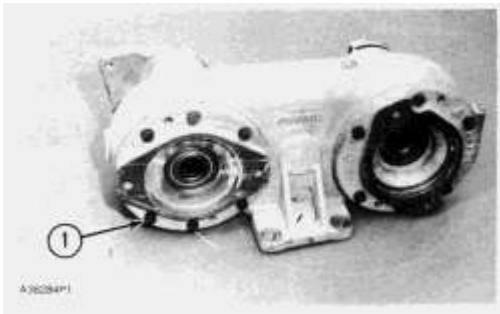

1. Remove bolts (1) that hold bearing cage (2) to the housing.
2. Install two 1/2" - 13 NC forcing screws (3), and remove the bearing cage.

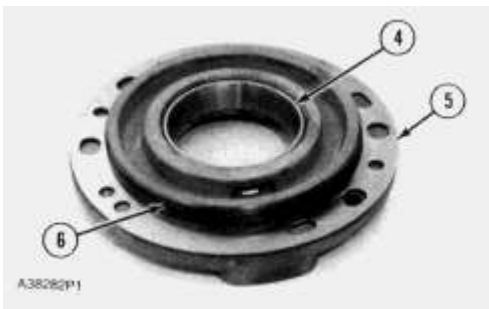

3. Remove shims (5) and O-ring seal (6) from the inside of cage (2). Inspect the seal, and make a replacement is needed.
4. Remove bearing cup (4) from the cage if a replacement is necessary.

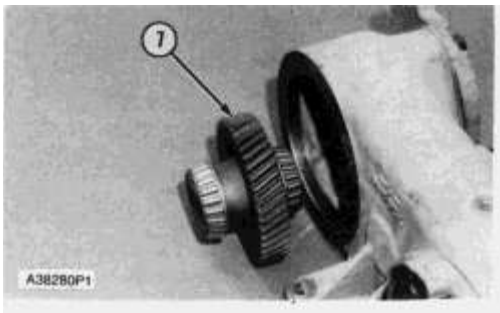

5. Remove bearing cones and gear assembly (7) from the housing.

<https://www.ebooklibonline.com>

Hello dear friend!

Thank you very much for reading.

Enter the link into your browser.

The full manual is available for immediate download.

<https://www.ebooklibonline.com>

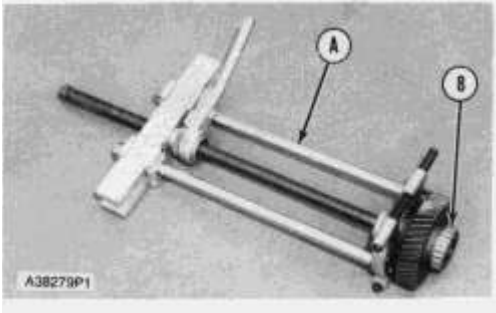

6. Use tooling (A) to remove bearing cones (8) from each side of the gear if a replacement is necessary.

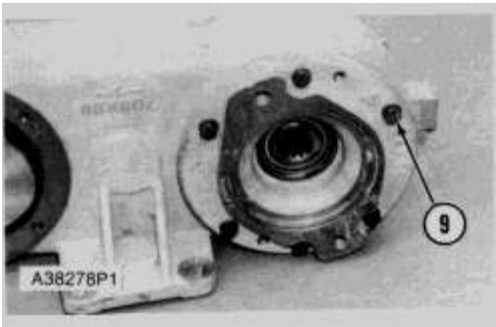

7. Remove six bolts (9) and the lockwashers that hold the bearing cage to the housing.

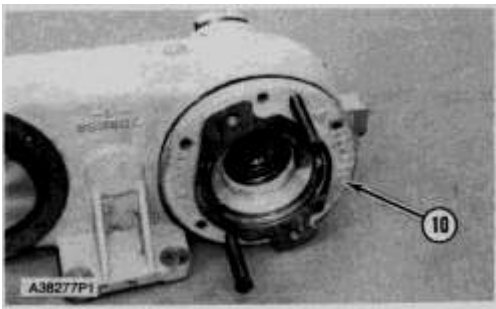

8. Install two 1/2" - 13 NC forcing screws, and remove bearing cage (10).

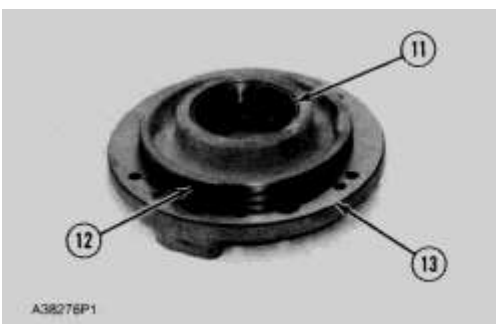

9. Remove shims (13) and O-ring seal (12). Inspect the seal, and make a replacement as needed.

10. Remove bearing cup (11) from the cage if a replacement is necessary.

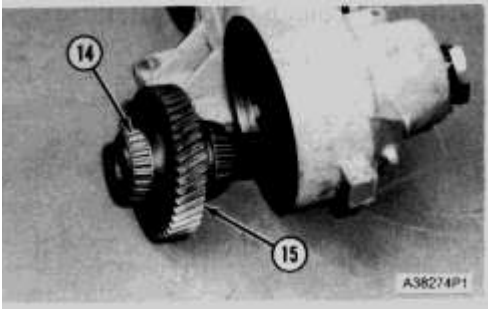

11. Remove bearing cones and gear assembly (15). Remove bearing cone (14) from each side of the gear with tooling (A).

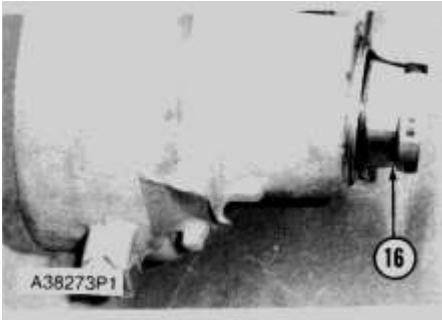

12. Remove yoke assembly (16) from the housing.

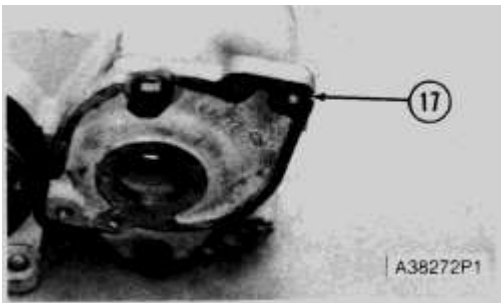

13. Remove the two bolts and lockwashers, and remove adapter (17).



14. Remove and inspect O-ring seal (18). Make a replacement of the seal if necessary.

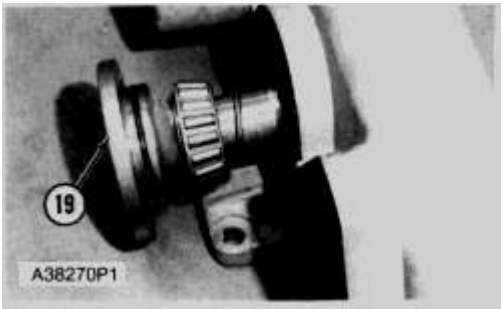

15. Remove the bolts from shaft (19), and install two 1/2" - 13 NC forcing screws. Remove the shaft from the gear and bearing assembly.

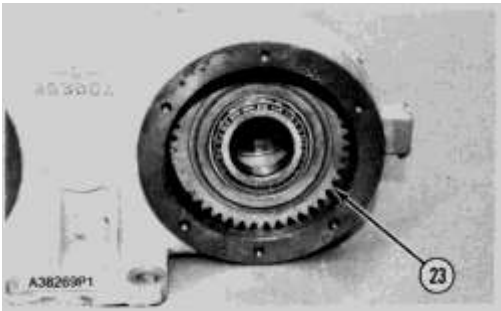

16. Remove ring (20) and bearing (21) from shaft (19). The bearing slides off the shaft with hand pressure. Remove O-ring seal (22), and inspect it. Make a replacement of the seal if necessary.

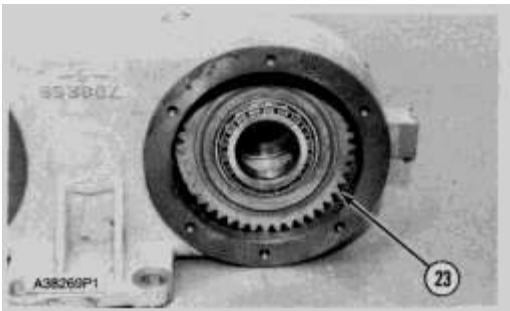

17. Remove gear (23) and the bearing after shaft (19) has been removed.

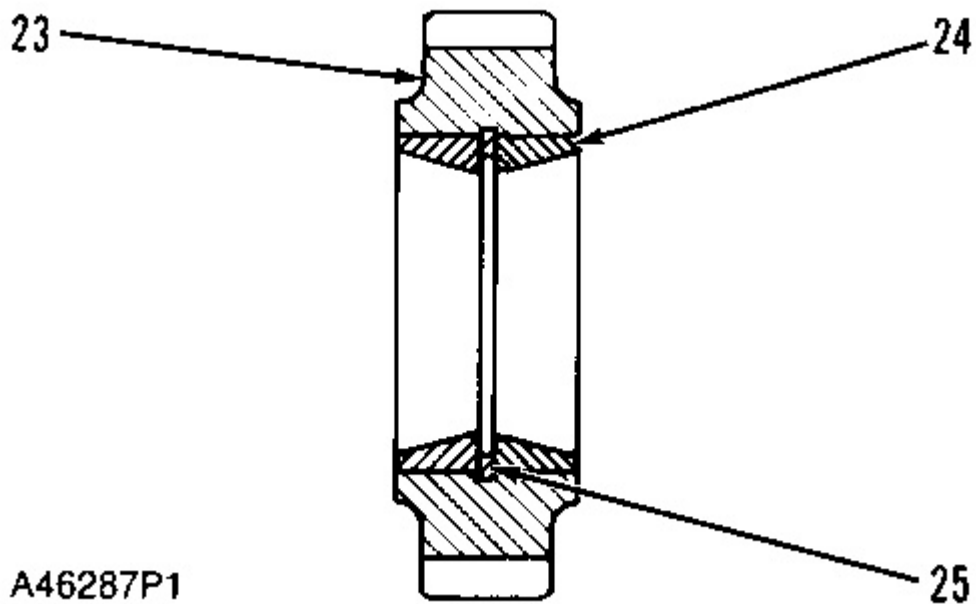

18. Remove bearing cups (24) from gear (23) if replacements are necessary. Remove ring (25) if a replacement is necessary.



19. Remove the bearing cup from the housing with tooling (B).

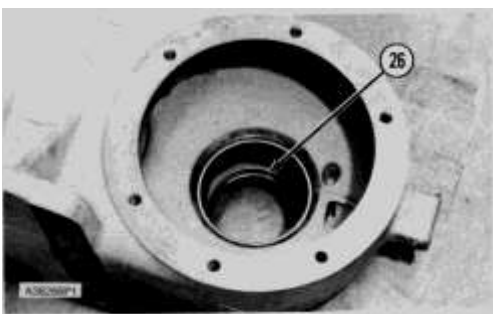

20. Inspect the lip-type seal (26) in the housing. Remove and make a replacement as needed. Install the seal with the lip toward the inside.

Assemble Pump Drive

Tools Needed		A	B	C	D
1P531	Handle*	1	1	1	
1P505	Drive Plate*	1			
1P498	Drive Plate*		1		
1P506	Drive Plate*			1	
8S2328	Dial Indicator Test Group				1

*Part of 1P520 Driver Group.



1. Install the lip-type seal in the housing with tooling (A). Be sure the lip of the seal is toward the inside of the housing.



2. Turn the housing over. Lower the temperature of the bearing cup. Use tooling (B) to install the bearing cup.
3. Use tooling (A) to install the other bearing cup (not shown) in the housing. Lower the temperature of the bearing cup prior to installation.

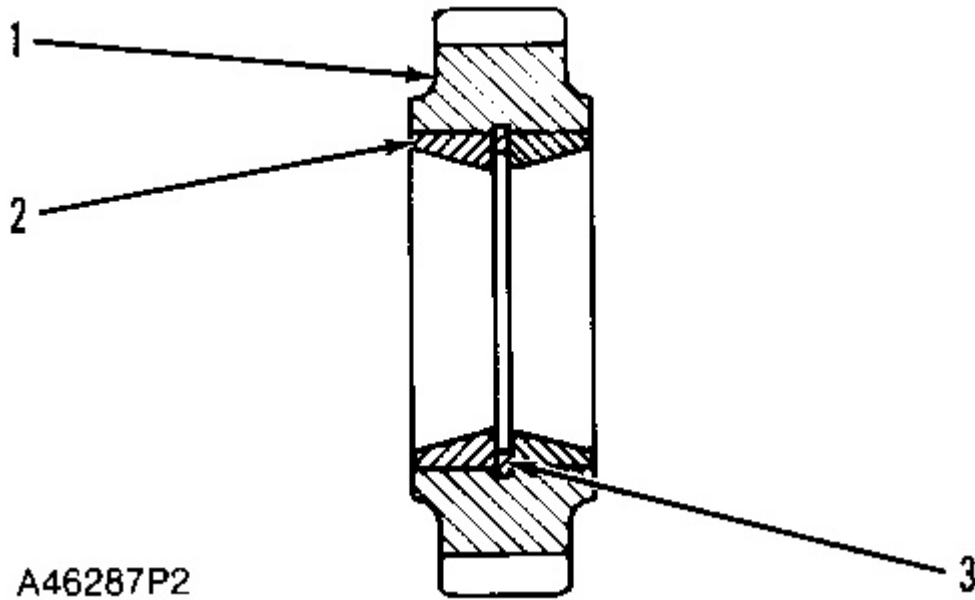

A46287P2

- 4. Install ring (3) in gear (1).
- 5. Lower the temperature of bearing cups (2). Use tooling (C) to install bearing cups (2) in gear (1).

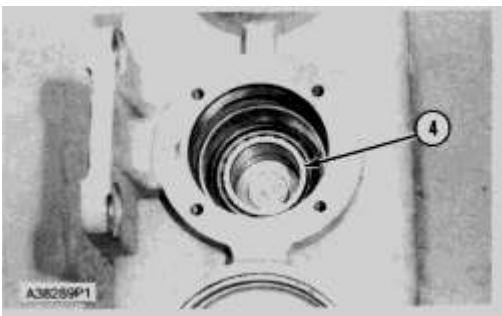

- 6. Put gear (1) and bearing cone (4) in position in the housing.

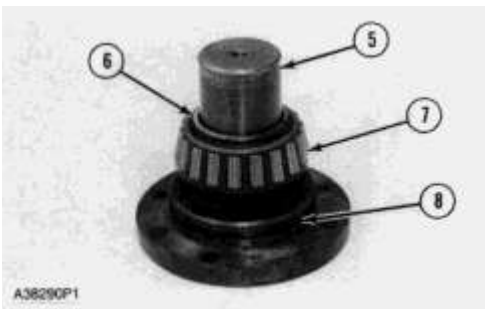

A38290P1

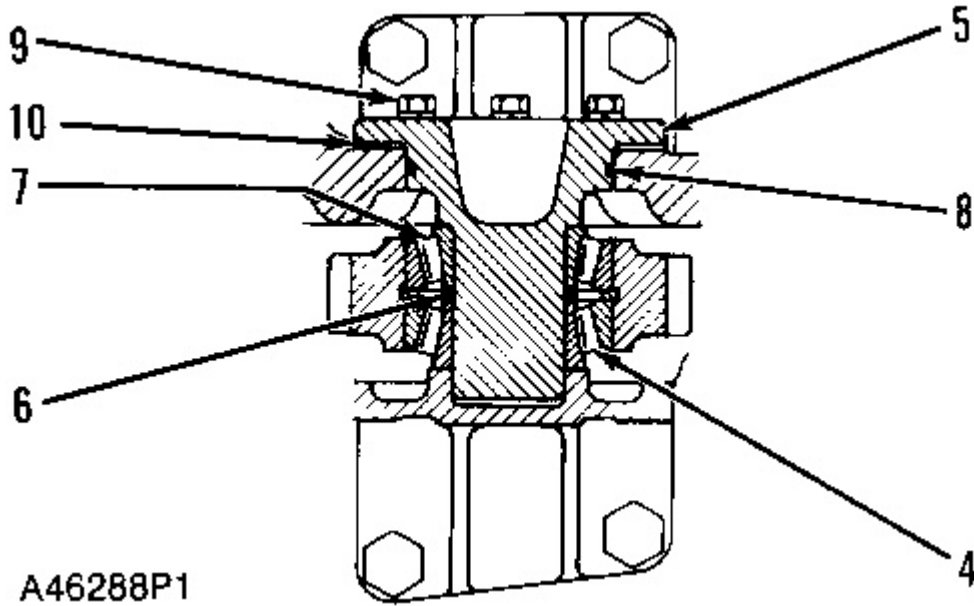

7. Use the procedure that follows to adjust the preload on bearing cones (4) and (7):

a. Install bearing cone (7) and ring (6) on shaft (5). Put the shaft (without shims and O-ring seal) in position in the housing and through gear (1) and bearing cone (4).

b. Install four bolts (9). Tighten the bolts evenly to a torque of $7 \pm 1 \text{ N}\cdot\text{m}$ ($5 \pm 1 \text{ lb ft}$). Measure the distance between the housing and shaft (5) at three locations. Make a shim pack (10) of the same thickness as the average measured distance minus 0.10 mm ($.004 \text{ in}$).

8. Remove shaft (5). Install O-ring seal (8) on the shaft.

9. Install the correct amount of shims (10) and shaft (5).

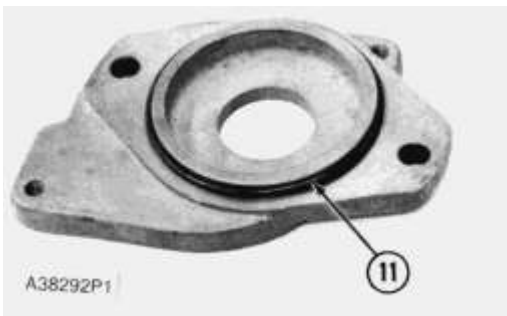

10. Install O-ring seal (11) on the adapter. Install the adapter on the housing.

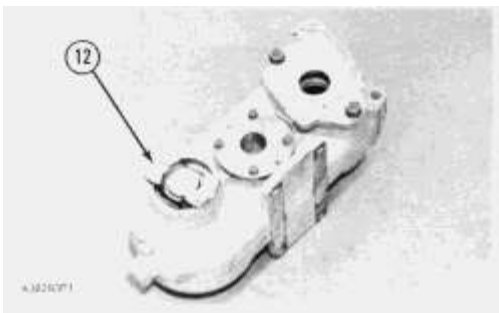

11. Put yoke assembly (12) in position in the housing.

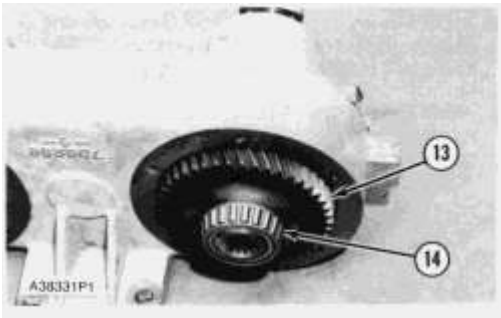

12. Heat bearing cones (14) in oil to a maximum temperature of **135°C (275°F)**. Install the bearings on each side of gear (13).

13. Install gear (13) in the housing. Make sure the splines on the yoke assembly and the splines on the gear assembly are in alignment.



14. Lower the temperature of the bearing cup. Use tooling (B) to install the cup in bearing cage (15).

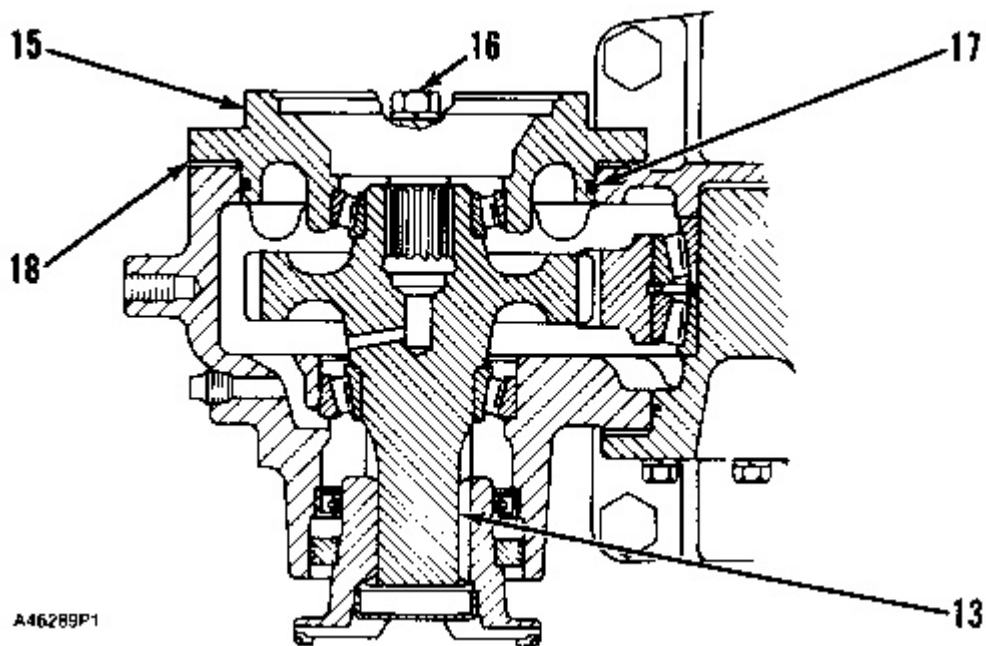

15. Use the procedure that follows to adjust the end plate of gear (13):

a. Install bearing cage (15) (without O-ring seal and shims). Tighten bolts (16) evenly until a small resistance is felt in the rotation of gear (13).

b. Measure the distance between the housing and cage (15) at three locations. Make a shim pack (18) of the same thickness as the average measured distance plus **0.10 mm (.004 in)**.

16. Remove bearing cage (15). Install O-ring seal (17) on bearing cage (15).

17. Install the correct amount of shims (18) and bearing cage (15). Use tooling (D) to measure the end play of gear (13). End play must be **0.05 to 0.15 mm (.002 to .006 in)**. Add or remove shims (18) to get the correct end play.

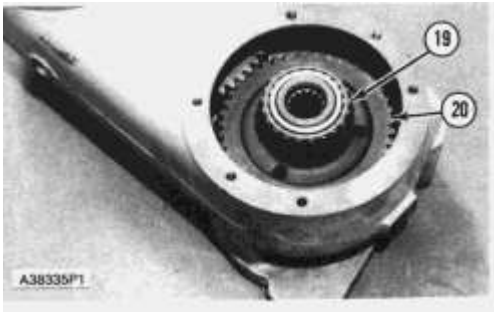

18. Heat bearing cones (19) in oil to a maximum temperature of **135°C (275°F)**. Install the bearings on each side of gear (20).

19. Install gear (20) in the housing.

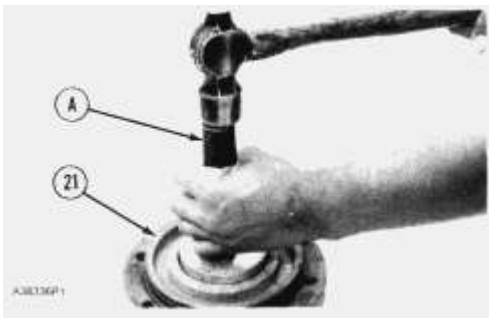

20. Lower the temperature of the bearing cup. Use tooling (A) to install the cup in bearing cage (21).

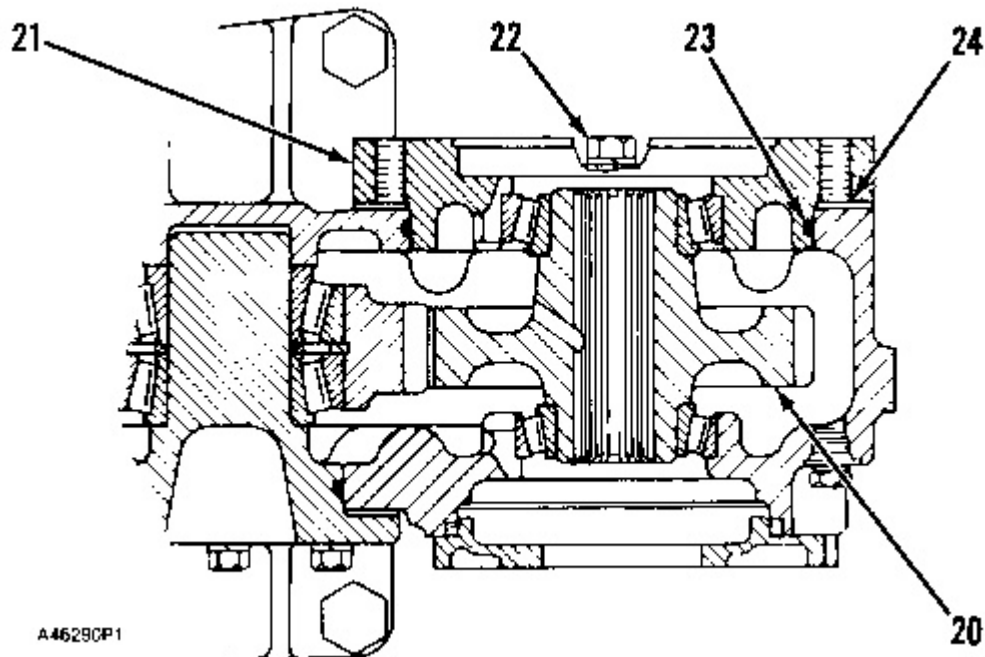

21. Use the procedure that follows to adjust the end play of gear (20):

a. Install bearing cage (21) (without O-ring seal and shims). Tighten bolts (22) evenly until a small resistance is felt in the rotation of gear (20).

b. Measure the distance between the housing and cage (21) at three locations. Make a shim pack (24) of the same thickness as the average measured distance plus **0.10 mm (.004 in)**.

22. Remove bearing cage (21). Install O-ring seal (23) on bearing cage (21).

23. Install the correct amount of shims (24) and bearing cage (21). Use tooling (D) to measure the end play of gear (20). End play must be **0.05 to 0.15 mm (.002 to .006 in)**. Add or remove shims (24) to get the correct end play.

NOTICE

After assembly, put in .946 liter (1 U.S. quart) of SAE 10W oil in the oil pump drive housing before the engine is started.

End By:

a. install pump drive

Product: TRACTOR

Model: 784B TRACTOR 5RK

Configuration: 784B Tractor 5RK00001-UP (MACHINE) POWERED BY 3512 Engine

Disassembly and Assembly 785B TRUCK MACHINE SYSTEMS

Media Number -SEN5678-01

Publication Date -01/09/2004

Date Updated -17/10/2012

SEN56780013

Steering Cylinders

SMCS - 4303-015; 4303-016; 4303-010

Remove & Install Steering Cylinders

Tools Needed		A
4C3386	Spanner Wrench	1

1. Drain the oil from the steering hydraulic tank.

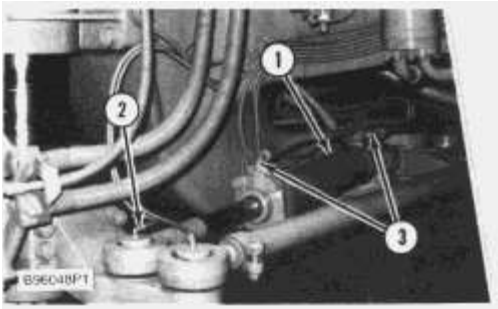

2. Disconnect lubrication lines (2) from each end of the cylinder.
3. Disconnect two hoses (3) from steering cylinder (1).
4. Loosen the nuts while holding the ballstud from turning with tool (A) on each end of the steering cylinder until the nut is even with the bottom of the ballstud.

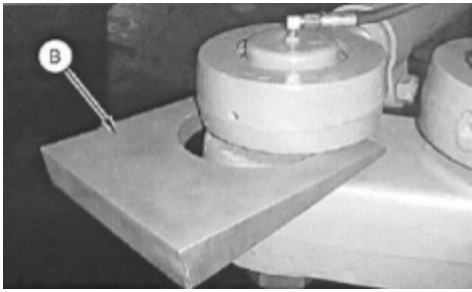

5. Place 231-4905 Wedge (B) in between the steering cylinder and the steering arm as shown. Strike tool (B) with a hammer in order to loosen the ball stud from the taper. Repeat this step for the remaining ballstuds.

6. Secure steering cylinder (1) to a floor jack. Remove the two nuts from the ballstuds, and remove the steering cylinder. The weight of the steering cylinder is **88 kg (194 lb)**.

NOTE: The following steps are for installation of the steering cylinder.

7. Put **4C5593 Thread Lubricant** on the threads and taper of the ballstuds.

8. Fasten steering cylinder (1) to a floor jack. Put the steering cylinder in position, and use tool (A) to hold ballstud from turning. Install the nuts on the ends of the ballstuds. Tighten the nuts to a torque of **2060 ± 100 N·m (1520 ± 75 lb ft)**.

9. Connect two hoses (3) to the steering cylinder.

10. Connect lubrication lines (2) to each end of the steering cylinder.

11. Fill the steering system hydraulic tank with oil to the correct level. See the Maintenance Guide.

12. Start the machine, and turn the wheels full right and full left several times to remove the air from the steering hydraulic system.

13. Check the level of oil in the steering system hydraulic tank again.

Disassemble Steering Cylinders

Tools Needed		A	B
6V4947	Hydraulic Cylinder Repair Stand	1	
3S6224	Hydraulic Pump Assembly	1	
1P850	Torque Multiplier		1
1P851	Spline Adapter		1
2P2265	Mounting Assembly		1
5S6079	Socket		1

Start By:

a. remove steering cylinders

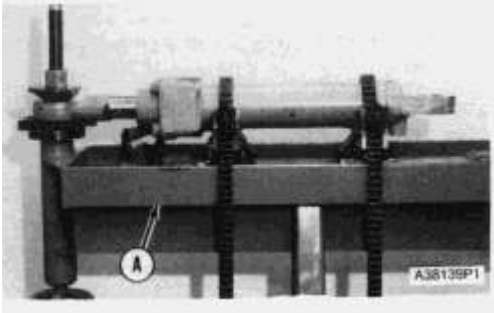

1. Put the cylinder into position on tool (A).

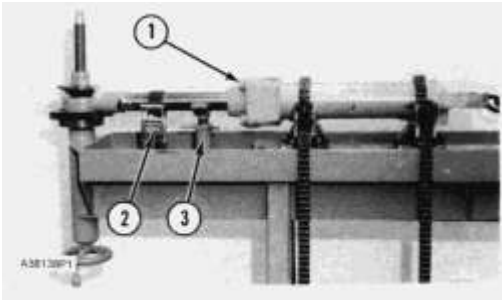

2. Install support (3) under the rod, and fasten strap (2) to hold the rod on the support.

3. Remove four bolts (1) and washers from the head. Remove the rod and the head from the cylinder.

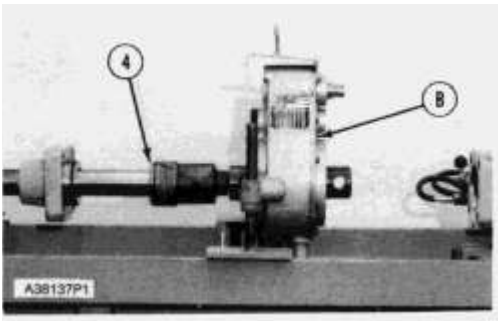

4. Remove the nut from the rod with tooling (B).

5. Remove piston (4) from the rod.

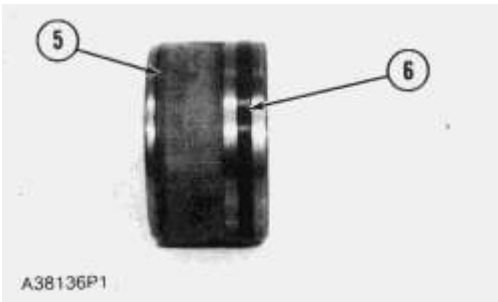

6. Remove wear ring (5) and seal assembly (6) from the piston. Inspect the seals and ring, and make replacements as needed.

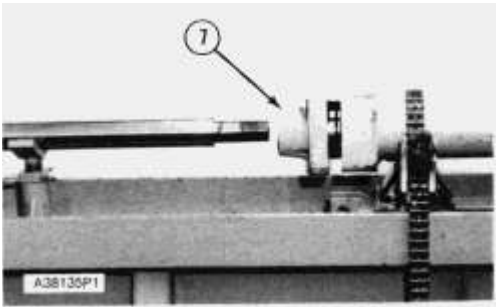

7. Install two 7/8" - 9 NC bolts through the head and in the cylinder. Move the rod out of head (7).

8. Remove head (7) and the bolts from the cylinder.

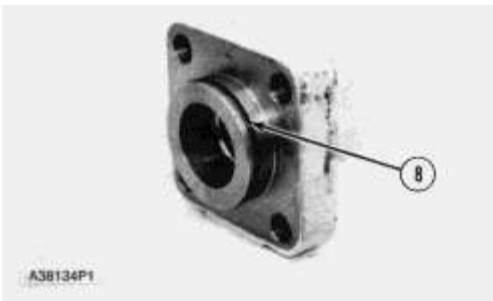

9. Remove O-ring seal and back-up ring (8) from outside of the head. Inspect the seal and ring, and make replacements as needed.

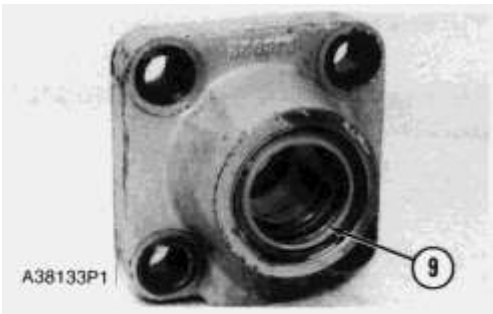

10. Remove seals (9) from inside the head. Make replacements as needed.

Assemble Steering Cylinders



Suggest:

For more complete manuals. Please go to the home page.

<https://www.ebooklibonline.com>

If the above button click is invalid. Please download this document first, and then click the above link to download the complete manual.

Thank you so much for reading

Tools Needed		A	B	C	D	E
1P510	Driver Group	1				
5P2980	Seal Installer		1			
2P8301	Seal Guide			1		
1P850	Torque Multiplier				1	
1P851	Spline Adapter				1	
2P2265	Mounting Assembly				1	
5S6079	Socket				1	
6V4947	Hydraulic Cylinder Repair Stand					1
3S6224	Hydraulic Pump Assembly					1

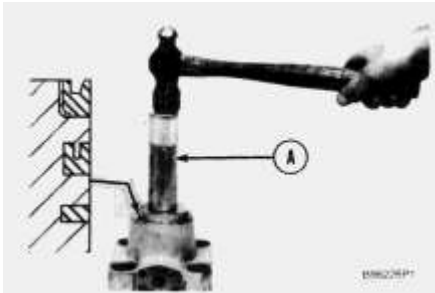

1. Install the lower seal and center seal in the head with tool (B). Install the seal ring in the lower groove and center seal with the lip of the center seal toward the outside of the cylinder. Install the outer seal with tooling (A). The lip of the outer seal must be toward the outside when installed.

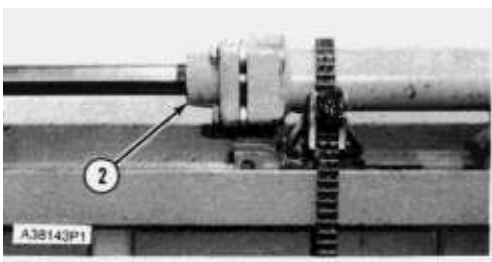
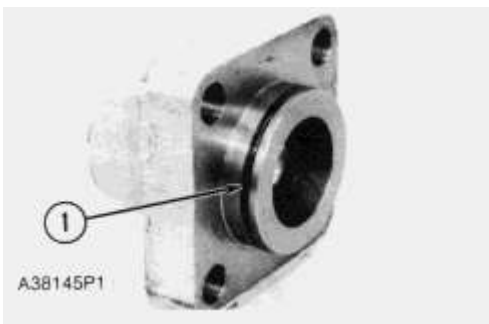

2. Install the O-ring seal and back-up ring on the outside of the head with back-up ring (1) toward the outside (bolt flange part of head). Put head (2) into position on the cylinder. Install 7/8"-9 NC bolts to hold the head in place.

3. Put clean SAE 10W oil on the seals in the head. Make sure the rod is in alignment with the head before the rod is installed. Install tool (C), and slowly push the rod through the head. Remove the bolts, and move the head back from the cylinder. Remove tool (C) from the rod.

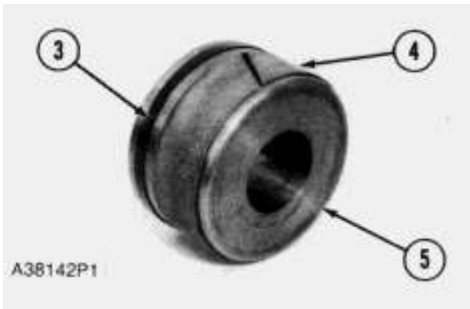

4. Install seal assembly (3) and wear ring (4) on the piston.

5. Install piston (5) and the nut on the rod.

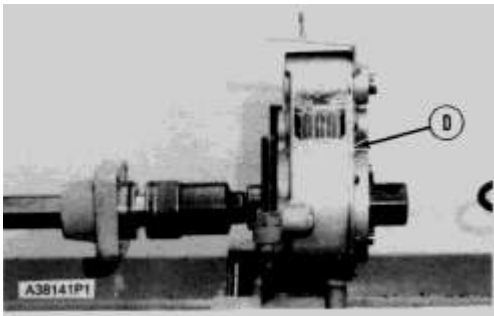

6. Install tooling (D), and tighten the nut to a torque of $2200 \pm 220 \text{ N}\cdot\text{m}$ ($1620 \pm 150 \text{ lb ft}$).

7. Remove tooling (D), and install the piston into the cylinder.

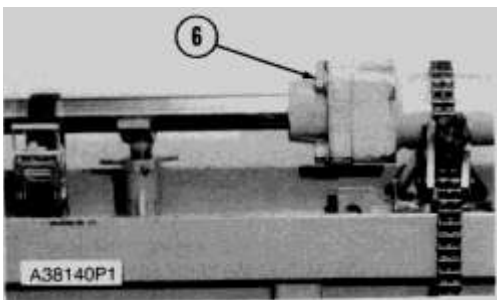

NOTICE

The rod must be fully extended when the lockwashers and bolts are tightened in the head. This will keep the cylinder, piston and head in better alignment.

8. Put the head into position on the cylinder, and install four bolts (6) and washers.

9. Remove the cylinder from tool (E).

<https://www.ebooklibonline.com>

Hello dear friend!

Thank you very much for reading.

Enter the link into your browser.

The full manual is available for immediate download.

<https://www.ebooklibonline.com>