

Product: TRUCK

Model: 777G TRUCK TNM

Configuration: 777G Off-Highway Truck TNM00001-UP (MACHINE) POWERED BY C32 Engine

## Disassembly and Assembly 777G Off-Highway Truck Power Train

Media Number -KENR9931-06

Publication Date -01/09/2018

Date Updated -26/09/2018

i07358548

# Torque Converter - Assemble

SMCS - 3101-016

## Assembly Procedure

Table 1

Required Tools			
Tool	Part Number	Part Description	Qty
A	439-3940	Link Bracket	2
C	1P-2420	Transmission Repair Stand	1
F	1P-0520	Driver Group	1
H	138-7573	Link Bracket	2
J	4F-7226	Bolt	2
K	138-7574	Link Bracket	2
L	2P-8312	Retaining Ring Pliers	1
N	2D-1201	Eyebolt	1
P	1P-0808	Multipurpose Grease	1
R	8S-9191	Bolt	2
S	1P-0808	Multipurpose Grease	1
T	4F-7226	Bolt	2
U	6V-4876	Lubricant	1

**Note:** Check all the O-ring seals and the components for wear or for damage. Replace the components, if necessary. Lubricate all the O-ring seals lightly with the lubricant that is being sealed. Clean all the components with a cloth that is free of loose material (lint).

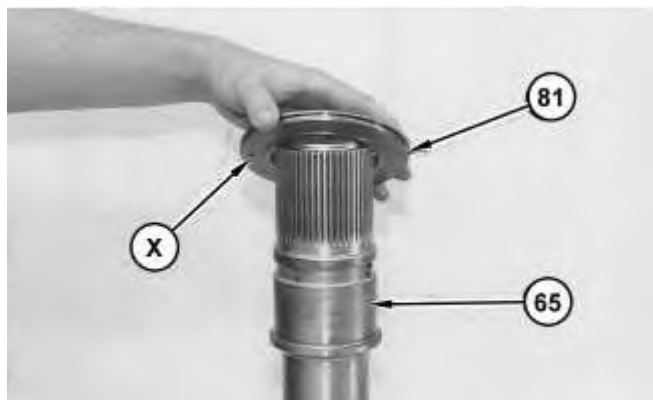

Illustration 1

g01322307

1. Install ring carrier (81) on output shaft (65) with the counterbore of hole (X) in the downward position.

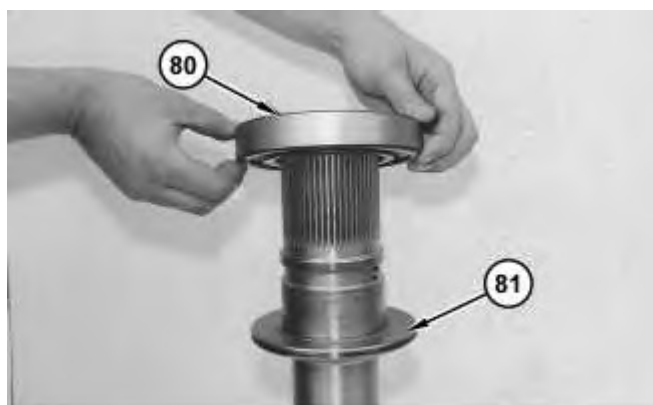

Illustration 2

g01322311

2. Install ball bearing (80) on top of ring carrier (81).



3. Install ring carrier (78) on top of ball bearing (80).

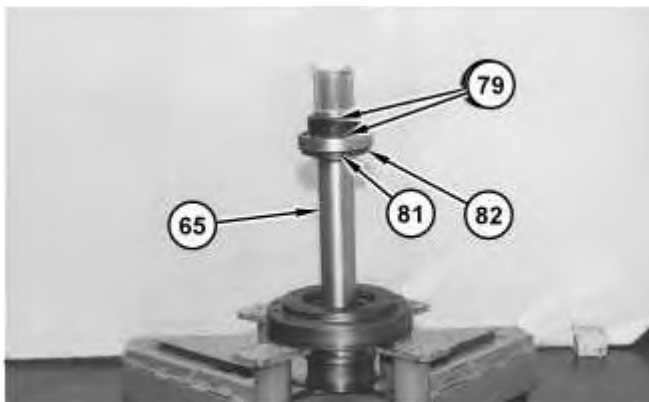

Illustration 4

4. Install seal rings (79) on ring carrier (78). Install seal ring (82) on ring carrier (81). Make sure that the ends of the seal rings are engaged.
5. Attach Tooling (N) (not shown) and a suitable lifting device to output shaft assembly (65). Install output shaft assembly (65).

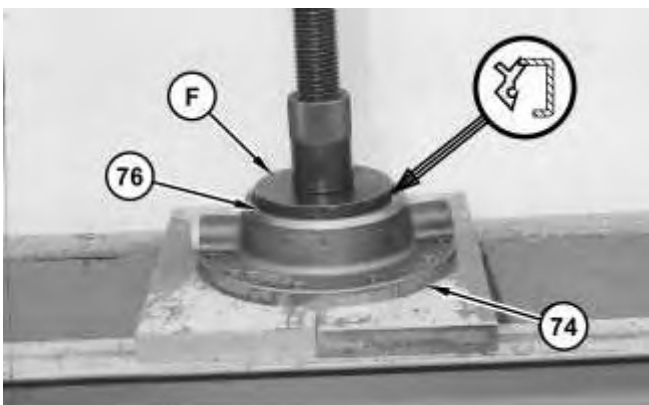

Illustration 5

6. Use Tooling (F) to install a new lip seal (76) in fluid distributor (74). Install the lip seal with the lips toward the inside.
-

**<https://www.ebooklibonline.com>**

Hello dear friend!

Thank you very much for reading.

Enter the link into your browser.

The full manual is available for immediate download.

**<https://www.ebooklibonline.com>**

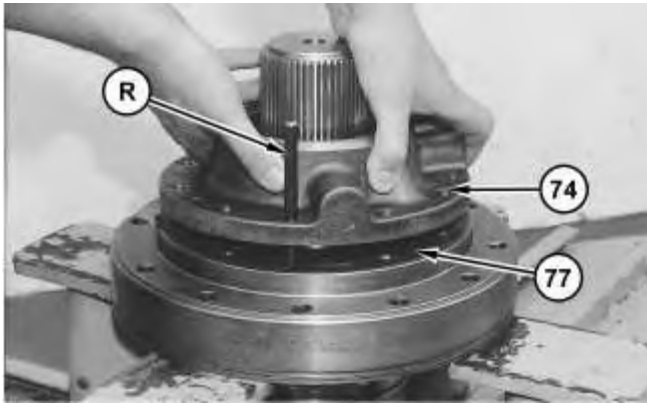

Illustration 6

g01322326

7. Tooling (R) must be modified to be used as guide bolts. Position Tooling (R) in a suitable vise (not shown). Remove the heads of the bolts.
8. Install Tooling (R) in the stator carrier. Install a new flat gasket (77). Install fluid distributor (74).

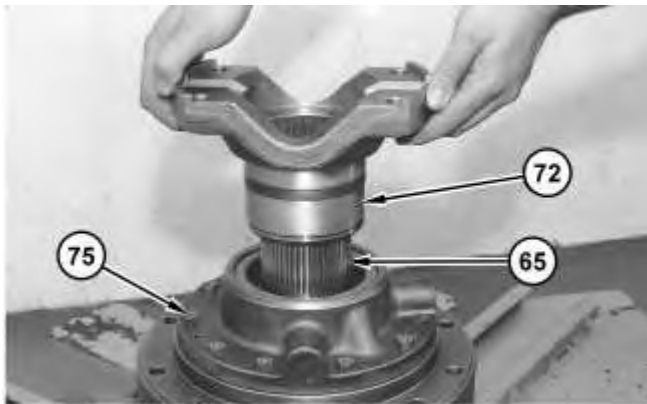

Illustration 7

g01322333

9. Install bolts (75). Tighten bolts (75) to a torque of  $50 \pm 7$  N·m ( $37 \pm 5$  lb ft).
10. Install yoke (72) on the splines of output shaft (65).

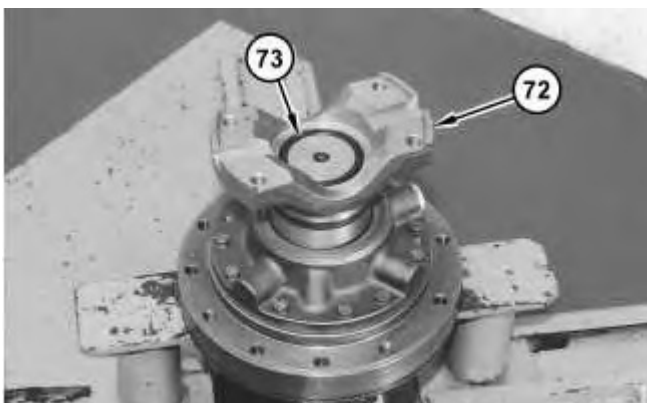

Illustration 8

g01322341

11. Install O-ring seal (73) on yoke (72).

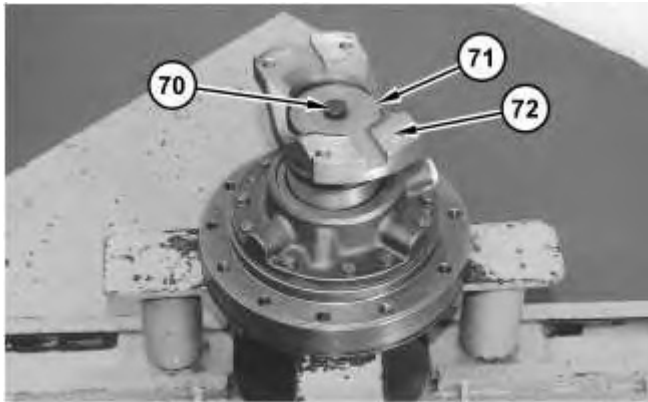

Illustration 9

g01322348

12. Install shaft retainer (71) and install bolt (70) that holds the shaft retainer in place. Tighten bolt (70) to a torque of  $240 \pm 25 \text{ N}\cdot\text{m}$  ( $177 \pm 18 \text{ lb ft}$ ).
13. Attach Tooling (K) (not shown) and a suitable lifting device to yoke (72).
14. Lift yoke (72) and the other components as a single unit. The weight of the assembly is approximately 73 kg (160 lb). Lay the assembly on a flat surface.

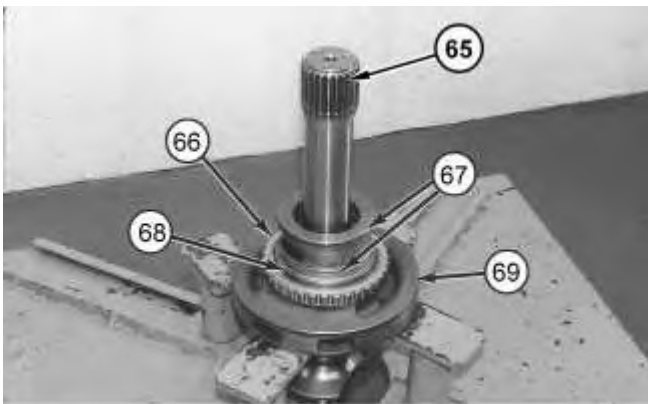
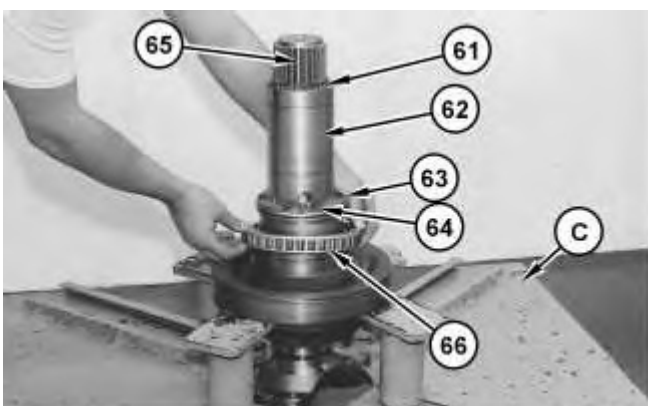

Illustration 10

g01322223



15. Attach Tooling (A) (not shown) and a suitable lifting device to output shaft (65).
16. Lift output shaft (65) and the other components as an assembly. Place the assembly in Tooling (C), as shown.
17. Install freewheel race (62) on output shaft (65).
18. Install split washers (63) and bolts (64).
19. Use Tooling (L) (not shown) to install retaining ring (61).
20. Install inner bearing (66) onto stator carrier (69) with the large inner radius in a downward position. Install seal rings (67).
21. Use Tooling (L) (not shown) to install retaining ring (68) on top of inner bearing (66).

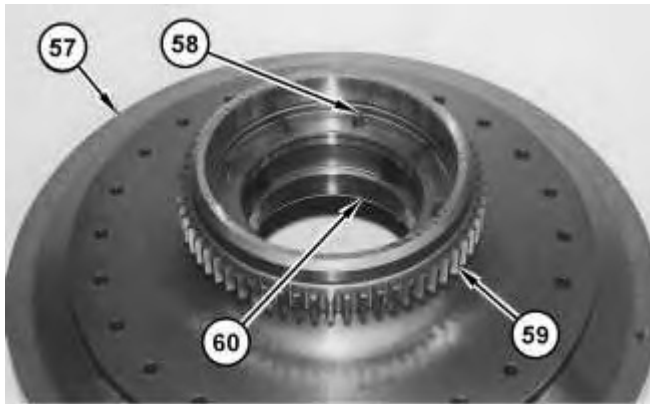

Illustration 12

22. Install pump drive gear (59) on rotating housing (57).
  23. Install bolts (58). Tighten bolts (58) to a torque of  $50 \pm 7 \text{ N}\cdot\text{m}$  ( $37 \pm 5 \text{ lb ft}$ ).
  24. Attach Tooling (K) (not shown) and a suitable lifting device to rotating housing (57). The weight of rotating housing (57) is approximately 82 kg (180 lb).
  25. Invert rotating housing (57).
  26. Install wear sleeve (60) on rotating housing (57).
-

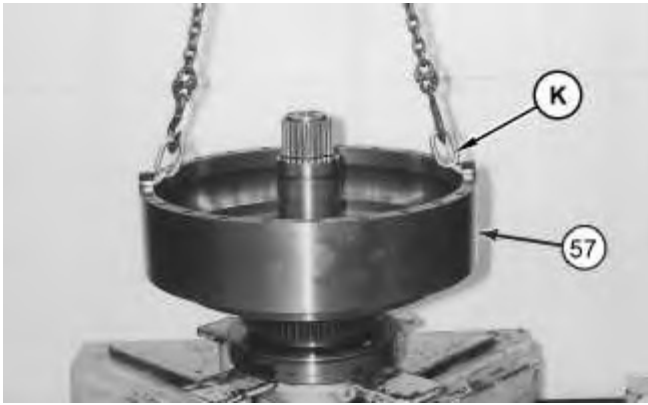

Illustration 13

g01322216

27. Attach Tooling (K) and a suitable lifting device to rotating housing (57). The weight of rotating housing (57) is approximately 82 kg (180 lb). Install rotating housing (57).



Illustration 14

g01322213

28. Install impeller (56).



Illustration 15

g01322209

29. Install 22 bolts (55) and the washers that hold the impeller to the rotating housing. Tighten bolts (55) to a torque of  $80 \pm 10$  N·m ( $60 \pm 7$  lb ft).

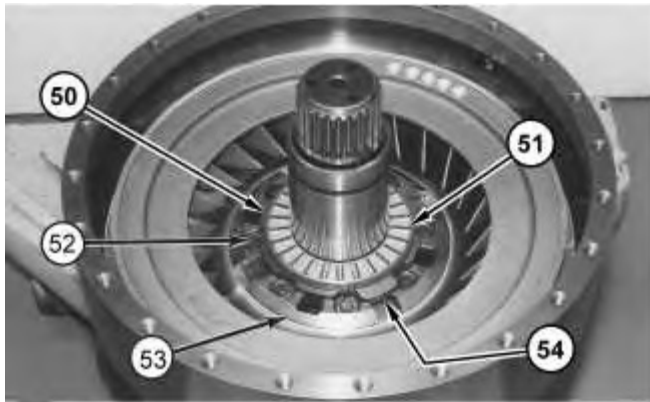

Illustration 16

g01322203

30. Install impeller hub assembly (54). Install bolts (52). Tighten bolts (52) to a torque of  $50 \pm 7 \text{ N}\cdot\text{m}$  ( $37 \pm 5 \text{ lb ft}$ ).
31. Install sleeve (50), thrust race (53) (not shown), and thrust bearing (51) on impeller hub assembly (54).

**Note:** Make sure that the grooves on the circumference of sleeve (50) are in alignment with the two thrust race pins in impeller hub assembly (54).

32. Refer to the following procedure to assemble the stator assembly:

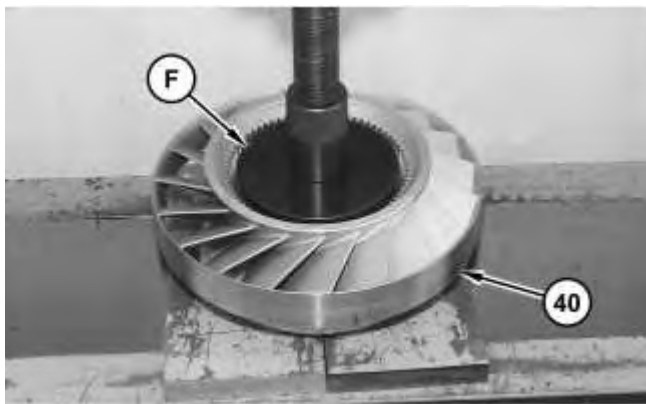

Illustration 17

g01322423

- a. Install the retaining ring (not shown) in stator (40).
- b. Position stator (40) in a suitable press with the chamfer in an upward position. Use Tooling (C) to install the freewheel cam in stator (40). Push the freewheel cam downward until the freewheel cam is against the retaining ring in the stator.

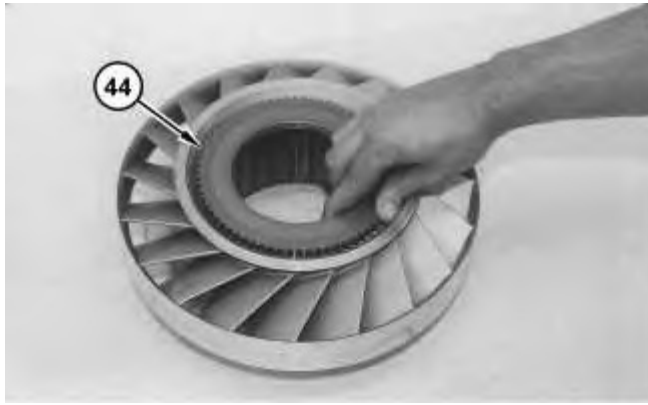

Illustration 18

g01322428

- c. Install side plate (44) in the stator. Push side plate (44) downward until the side plate is against the bottom of the freewheel cam.



Illustration 19

g00641312

- d. Use a hammer and a suitable punch to stake two opposite splines on the stator. This will hold the side plate in position.
- e. Turn over the stator.

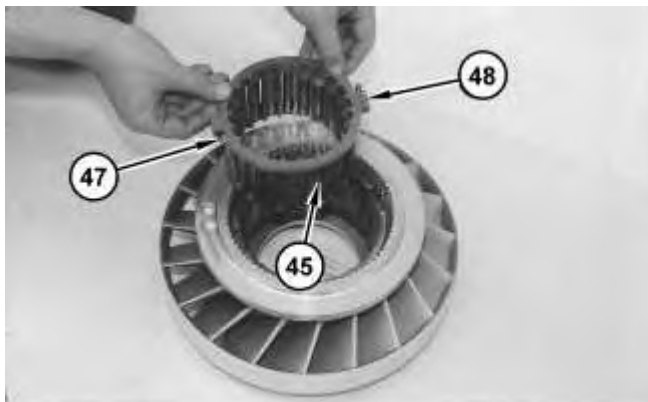

Illustration 20

g01322588

- f. Put a thin layer of Tooling (S) on each of the 22 freewheel rollers (45). Install the freewheel rollers in roller cage (48).
- g. Install springs (47) in roller cage (48).
- h. Install roller cage (48) in the freewheel cam.

**Note:** Make sure that all freewheel rollers (45) are in the correct positions.

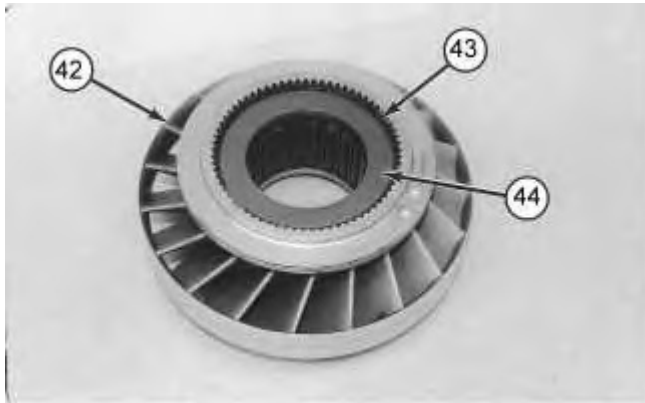

Illustration 21

g01322201

- i. Install side plate (44). Install retaining ring (43) that holds the side plate in position in stator (42).

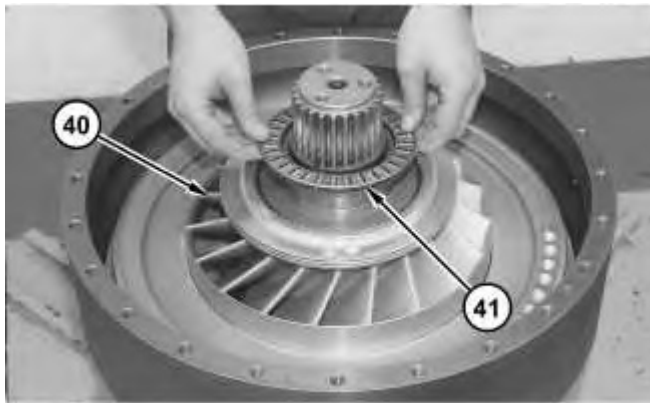

Illustration 22

g01322592

33. Install stator assembly (40) on the freewheel race of the output shaft.
  34. Install thrust bearing (41) on stator assembly (40).
-

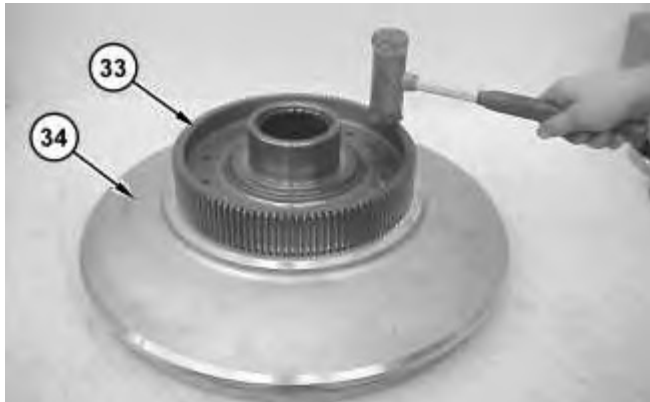

Illustration 23

g01322602

35. Refer to the following procedure to assemble clutch hub (33) and turbine (34):
- a. Position clutch hub (33) on turbine (34). Align the splines and apply a downward force on clutch hub (33) to install the clutch hub on the turbine. Turn over turbine (34).

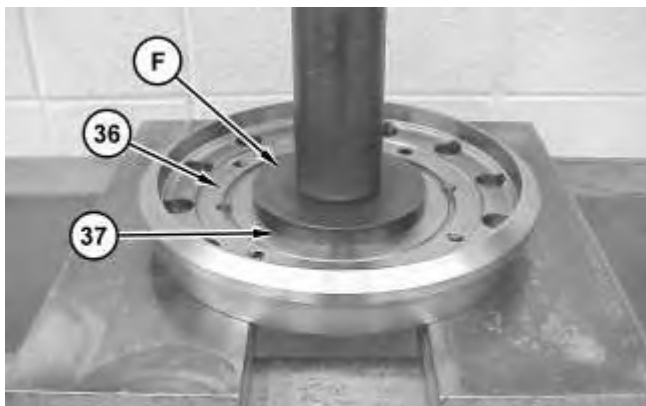

Illustration 24

g01322178

- b. Use Tooling (F) to install sleeve bearing (37) in hub assembly (36). The sleeve bearing must be even with the top surface of the hub assembly.

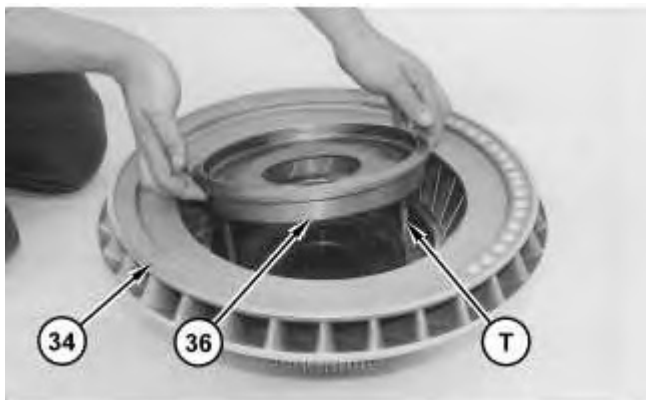

Illustration 25

g01322620

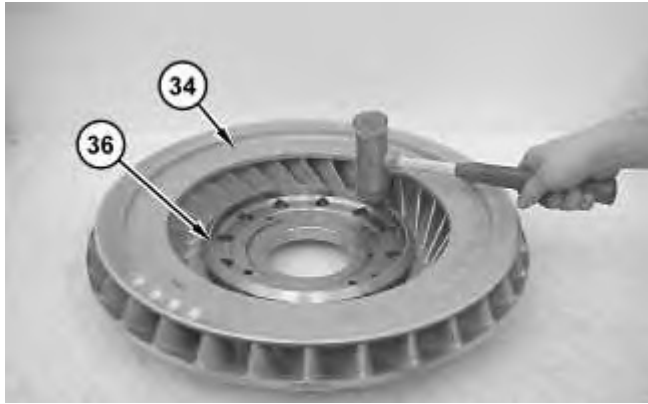

Illustration 26

g01322621

- c. Install Tooling (T) in clutch hub (36).
- d. Position hub assembly (36) on Tooling (H).
- e. Apply a downward force on hub assembly (36) to install the hub assembly in turbine (34). Remove Tooling (T).

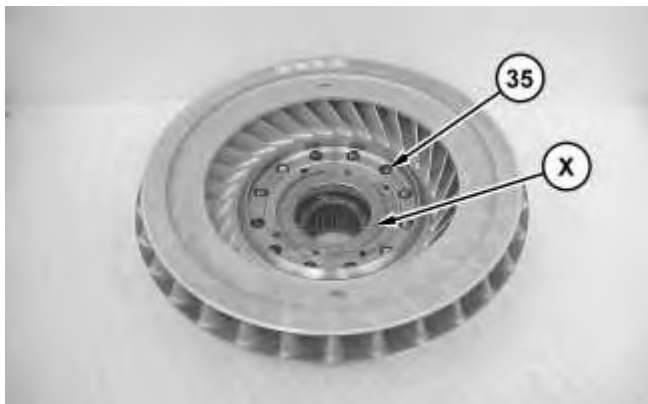
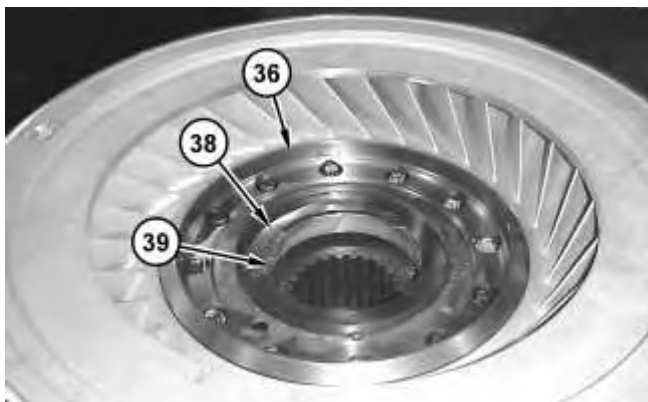

Illustration 27

g01322625

- f. Install bolts (35). Tighten bolts (35) to a torque of  $80 \pm 100$  N·m ( $60 \pm 7$  lb ft).
- g. Apply a thick layer of Tooling (U) to Surface (X) to hold the sleeve and the thrust race in position.



- h. Install sleeve (38) and thrust race (39).

**Note:** Make sure that the grooves in sleeve (38) are aligned with the two thrust race pins that are located in hub assembly (36).

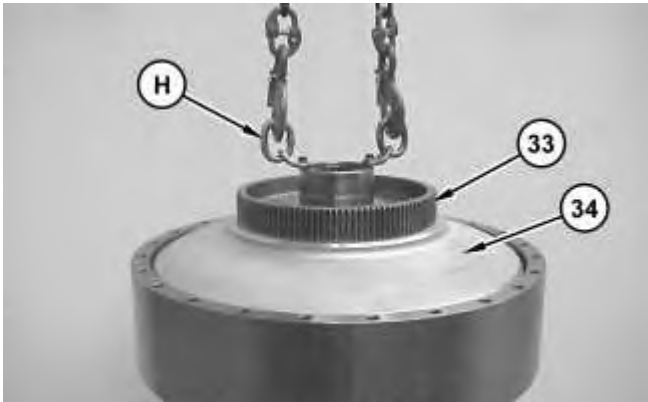

Illustration 29

g01322108

36. Turn over turbine (34). Attach Tooling (H) and a suitable lifting device to clutch hub (33).
37. Lift clutch hub (33) and turbine (34) as a single unit. The weight of the assembly is approximately 36 kg (80 lb). Position the assembly on the splines of the output shaft, as shown.



Illustration 30

g01322643

38. Install seal ring (26) on clutch carrier (9).

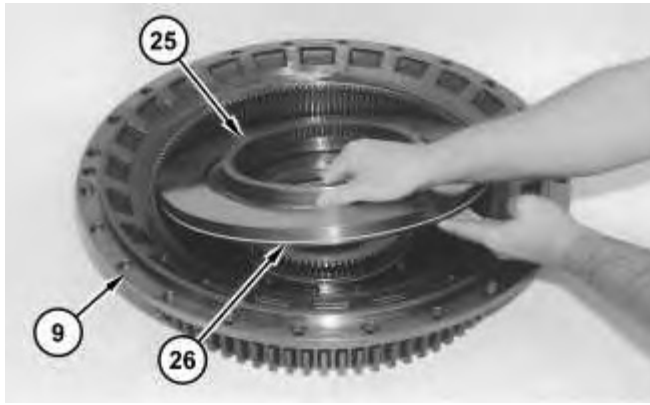

Illustration 31

g01322645

39. Install seal ring (26) on lockup clutch piston (25).
40. Install lockup clutch piston (25) in clutch carrier (9).

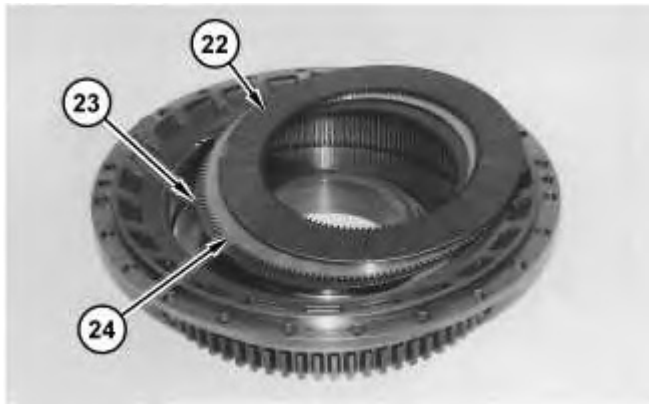

Illustration 32

g01322013

41. Install friction disc (23) and clutch plate (24). Install a second friction disc (22) on top of the clutch plate.

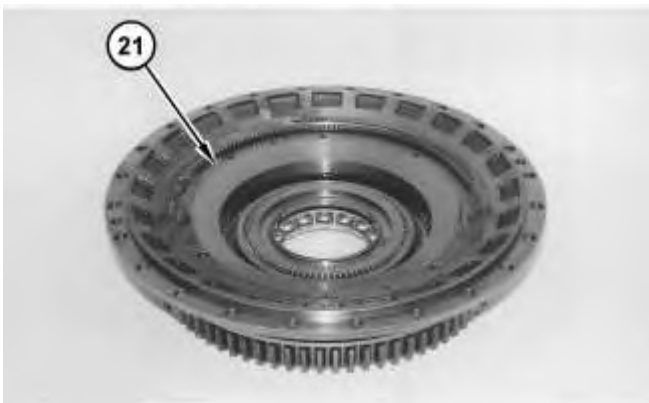

Illustration 33

g01322008

42. Install backing plate (21).



Illustration 34

g01322007

43. Install split washers (19) and bolts (20). Tighten bolts (20) to a torque of  $50 \pm 7$  N·m ( $37 \pm 5$  lb ft).
44. Attach Tooling (E) (not shown) and a suitable lifting device to the clutch carrier.
45. Lift the clutch carrier and turn over the clutch carrier. The weight of the clutch carrier is approximately 104 kg (230 lb).

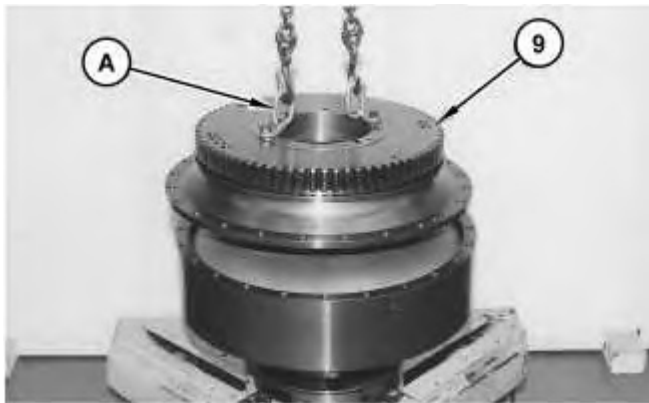

Illustration 35

g01322659

46. Attach Tooling (A) and a suitable lifting device to clutch carrier (9).
47. Lift clutch carrier (9) and install the clutch carrier on the clutch hub, as shown.

**Note:** The two friction discs inside clutch carrier (9) must engage correctly with the splines of the clutch hub before the clutch carrier will make contact with the rotating housing.

48. Install the bolts that hold clutch carrier (9) on the rotating housing . Tighten the bolts to a torque of  $240 \pm 25$  N·m ( $178 \pm 18$  lb ft).

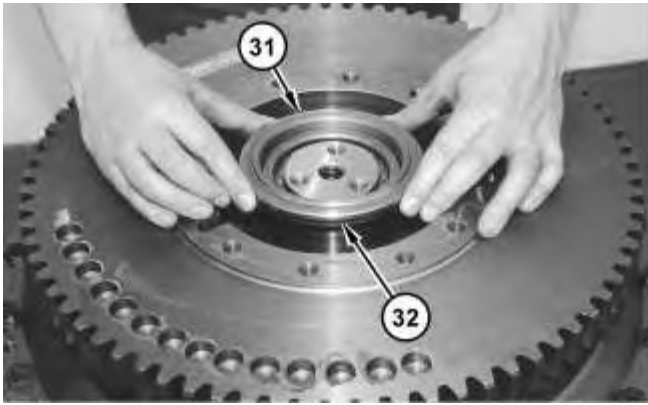

Illustration 36

g01322667

49. Install seal ring (32) on ring carrier (31). Make sure that the ends of the seal ring are engaged.
50. Install ring carrier (31).



Illustration 37

g01322675



Illustration 38

g00641919

51. Install wear sleeve (29).

52. Use a brass drift and a hammer to position wear sleeve (29) in the shoulder of the clutch carrier.



Illustration 39

g01322679



Illustration 40

g00641922

53. Install the bottom half of inner bearing race (30).
54. Use a brass drift and a hammer to position the bottom half of the inner bearing race (30) against the ring carrier.



Illustration 41

g01322681

---



**Suggest:**

**For more complete manuals. Please go to the home page.**

**<https://www.ebooklibonline.com>**

**If the above button click is invalid. Please download this document first, and then click the above link to download the complete manual.**

**Thank you so much for reading**

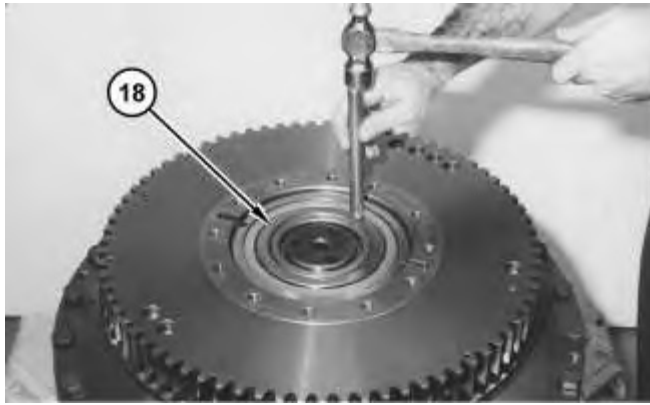

Illustration 42

g01322703

55. Install ball bearing (27).
56. Install the top half of inner bearing race (18).
57. Use a brass drift and a hammer to evenly position ball bearing (27) and inner bearing race (18). Make sure that the ball bearing turns freely when the inner bearing race is in place.

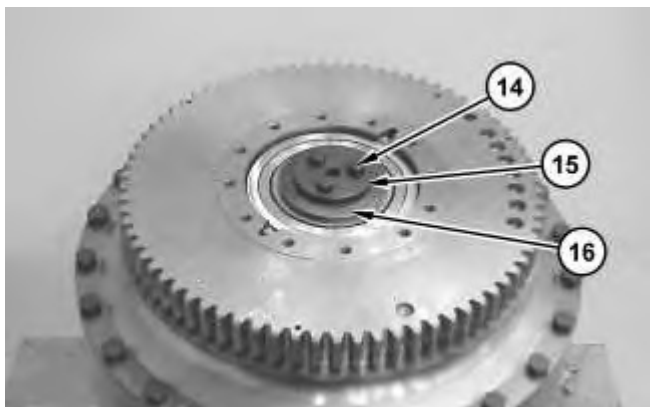

Illustration 43

g01321941

58. Install spring washer (16) and install retainer plate (15).
59. Install bolts (14) that hold retainer plate (15) in position. Tighten bolts (14) to a torque of  $120 \pm 15 \text{ N}\cdot\text{m}$  ( $90 \pm 11 \text{ lb ft}$ ).





**<https://www.ebooklibonline.com>**

Hello dear friend!

Thank you very much for reading.

Enter the link into your browser.

The full manual is available for immediate download.

**<https://www.ebooklibonline.com>**