

Product: TRUCK

Model: 777G TRUCK T5A

Configuration: 777G OEM Off-Highway Truck T5A00001-UP (MACHINE) POWERED BY C32 Engine

Disassembly and Assembly C27 and C32 Engines for Caterpillar Built Machines

Media Number -KENR8148-13

Publication Date -01/09/2018

Date Updated -05/09/2018

i04582133

Gear Group (Rear) - Remove and Install

SMCS - 1206-010; 1212-010

Removal Procedure

Table 1

Required Tools			
Tool	Part Number	Part Description	Qty
A	1P-0520	Driver Group	1
B	138-7575	Link Bracket	1
C	230-6262	Sealant	1
D	-	Guide Stud 5/8 - 18 by 12 inch	1

1. Remove the necessary bolts from the oil pan. Refer to Disassembly and Assembly, "Oil Pan - Remove and Install".

Note: Prior to removal of the flywheel, position the number one piston in the top center position (TC). The engine should be at the top center position to install the rear gear group. Refer to Testing and Adjusting, "Finding Top Center Position for No. 1 Piston".



(X) Marker

(Y) Alignment Mark

2. With the number one piston in the top center position (TC), attach a Marker to the engine. Place an Alignment Mark on the vibration damper.
3. Remove the flywheel housing. Refer to Disassembly and Assembly, "Flywheel Housing - Remove and Install".

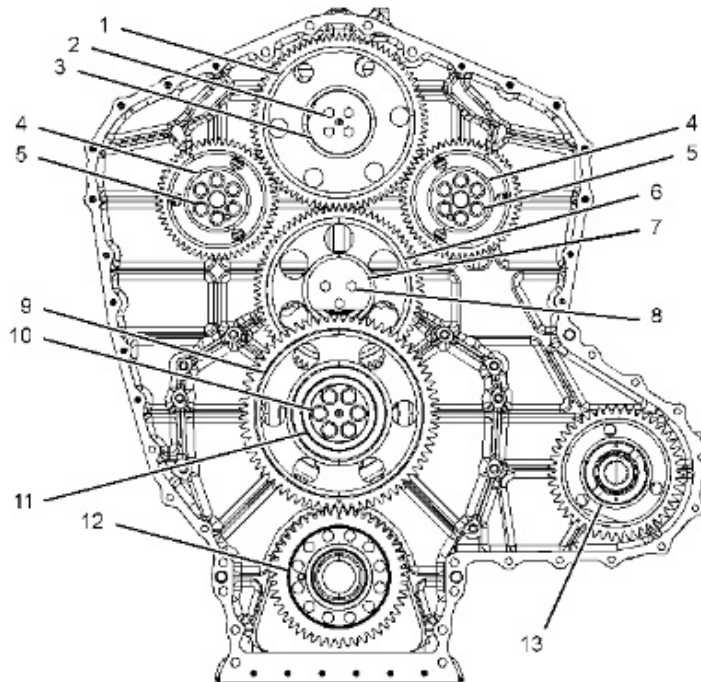

4. Remove bolts (10), thrust plate (11), and gear assembly (9).
 5. Use Tooling (A) and a suitable press to remove the bearing from gear assembly (9).
 6. Remove bolts (8), plate (7), and gear assembly (6).
 7. Use Tooling (A) and a suitable press to remove the bearing from gear assembly (6).
 8. Remove bolts (2), gear assembly (1), and shaft assembly (3).
 9. Use Tooling (A) and a suitable press to remove the bearing from gear assembly (1).
 10. Remove gear assembly (12).
 11. Remove bolts (5) and gear assemblies (4).
-

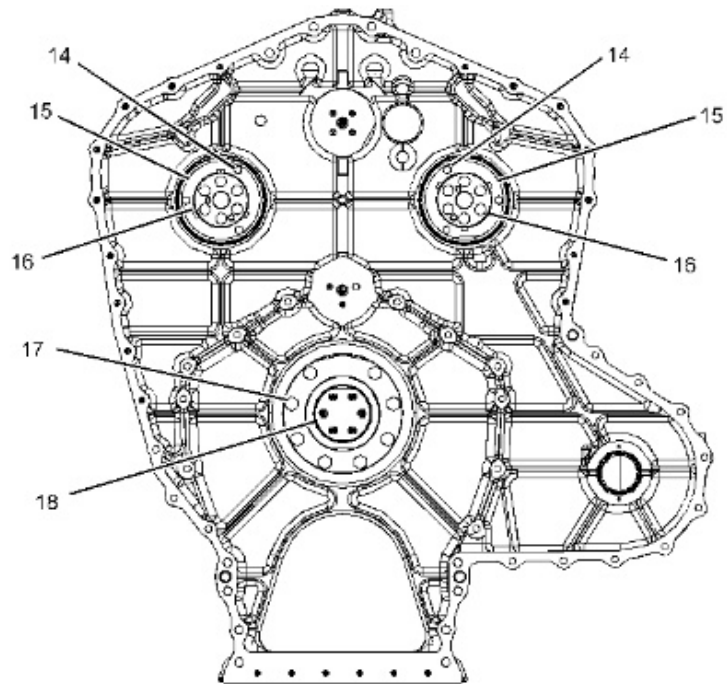

Illustration 3

g02737039

12. Remove bolts (17) and shaft assembly (18).
13. Remove bolts (14), thrust plates (15), and adapter assemblies (16).
14. Use bolt (14) in order to remove the sealing plates. Remove the O-ring seals.

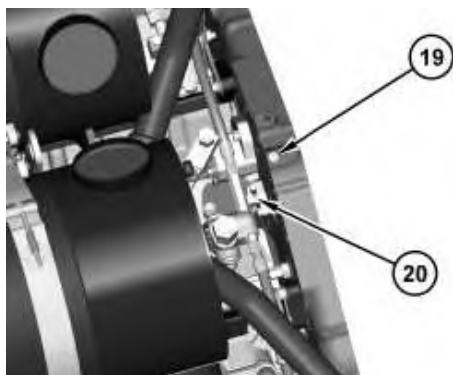

Illustration 4

g02738378

<https://www.ebooklibonline.com>

Hello dear friend!

Thank you very much for reading.

Enter the link into your browser.

The full manual is available for immediate download.

<https://www.ebooklibonline.com>

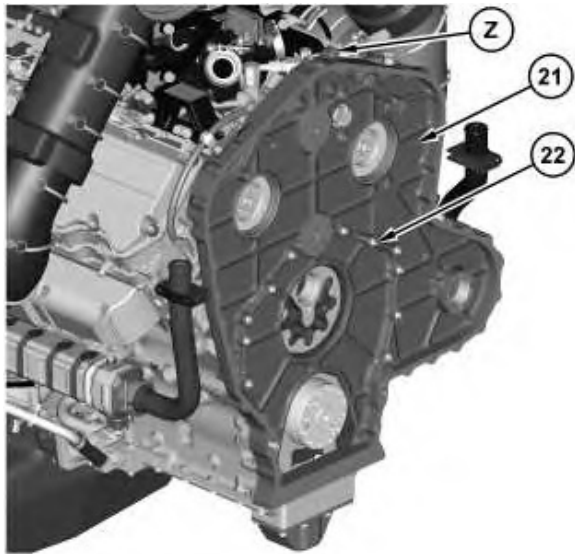

Illustration 5

g02738418

15. Remove plug (19) and disconnect hose assembly (20).
16. Attach Tooling (B) to Location (Z). The weight of rear housing (21) is 84 kg (185 lb).
17. Remove bolts (22). Remove rear housing (21).

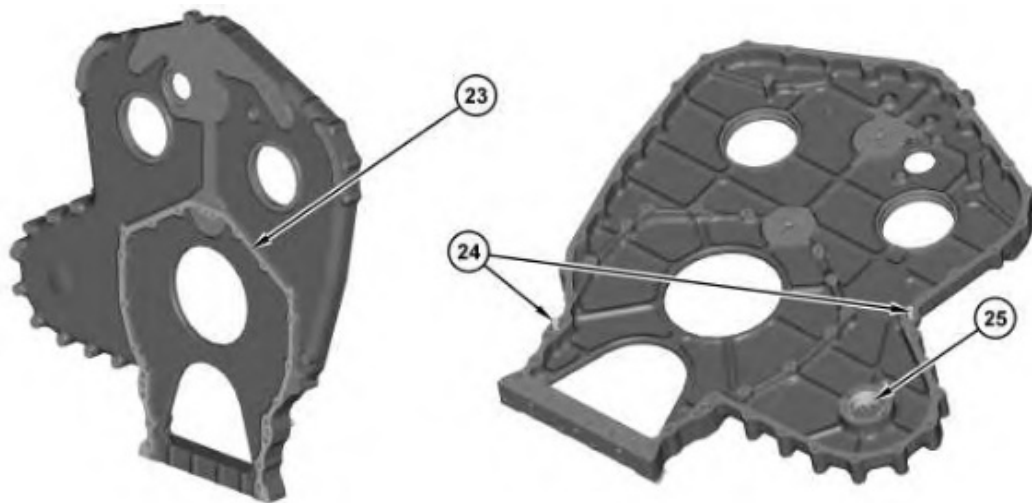

Illustration 6

g02738597

18. Remove gasket (23).
19. Remove dowels (24). Remove bearing sleeve (25) and the dowels.

Installation Procedure

NOTICE

Keep all parts clean from contaminants.

Contaminants may cause rapid wear and shortened component life.

Note: Make sure that the housing and the face of the block are free of contaminants prior to installation.

Note: Apply clean engine oil to the bearings and the shaft assemblies prior to installation on the engine.

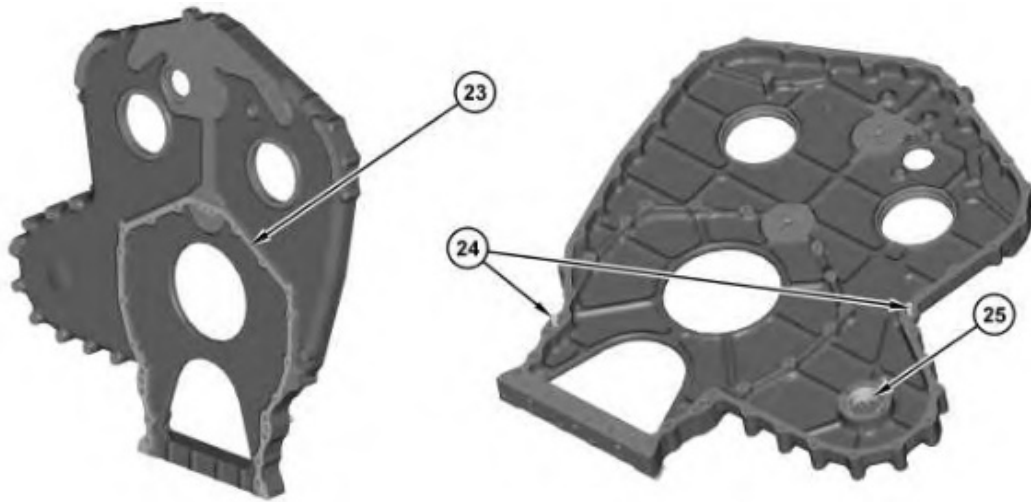

Illustration 7

g02738597

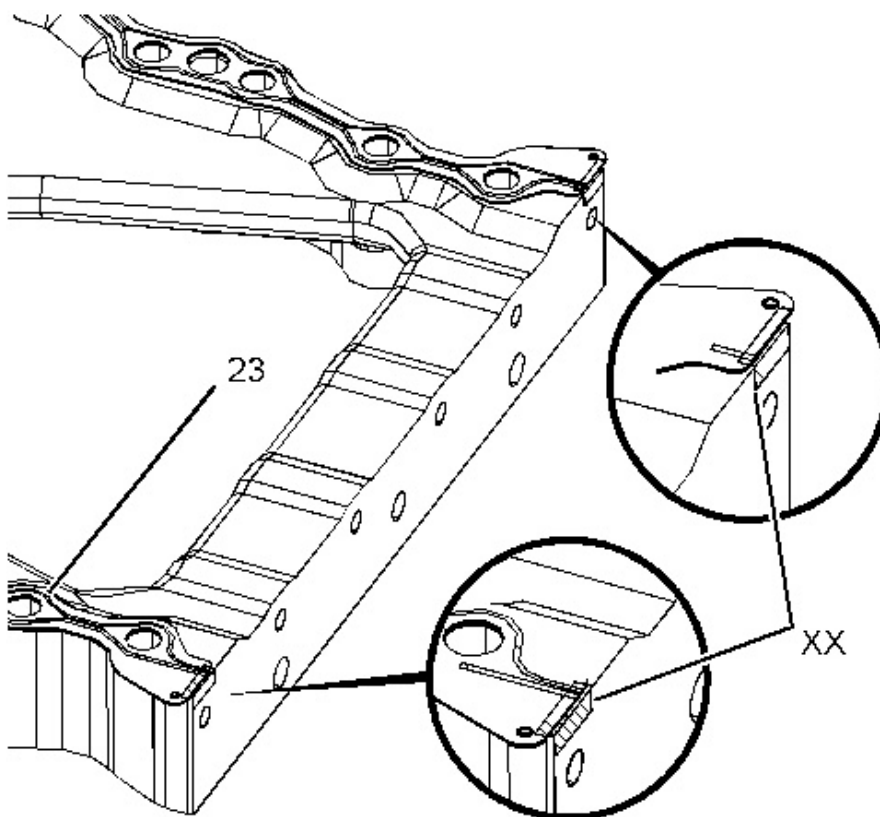

Illustration 8

g02738776

1. Install dowels (24). Use Tooling (A) to install bearing sleeve (25). Install the dowels.

2. Install gasket (23). Apply a continuous bead of Tooling (C) to Areas (XX). The sealant should span the entire width of the T-Joint .

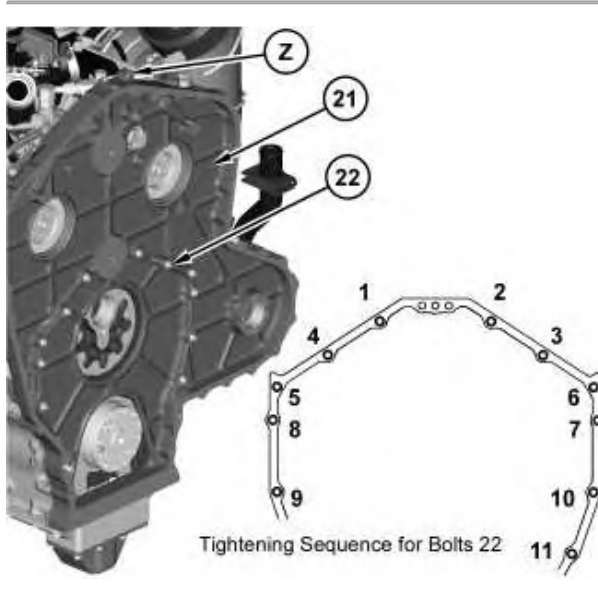

Illustration 9

g02738904

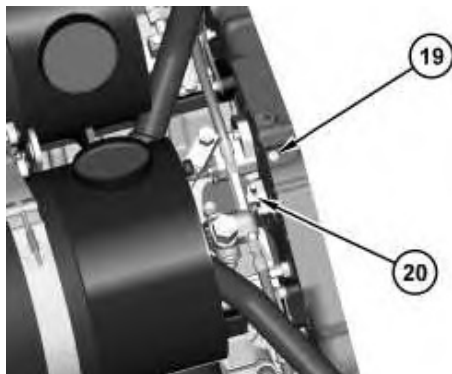

Illustration 10

g02738378

3. Attach Tooling (B) to Location (Z). The weight of rear housing (21) is 84 kg (185 lb).
 4. Position rear housing (21). Install bolts (22). Tighten bolts (22) to a torque of 55 ± 10 N·m (41 ± 7 lb ft) using the sequence in Illustration 9.
-

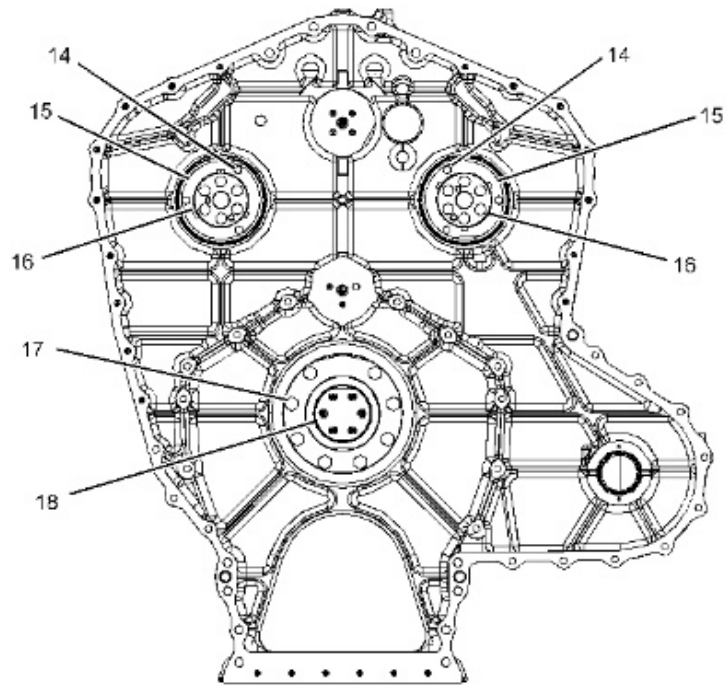

Illustration 11

g02737039

5. Install the O-ring seals and the sealing plates.
6. Install adapter assemblies (16), thrust plates (15), and bolts (14).
7. Position shaft assembly (18) and install bolts (17).

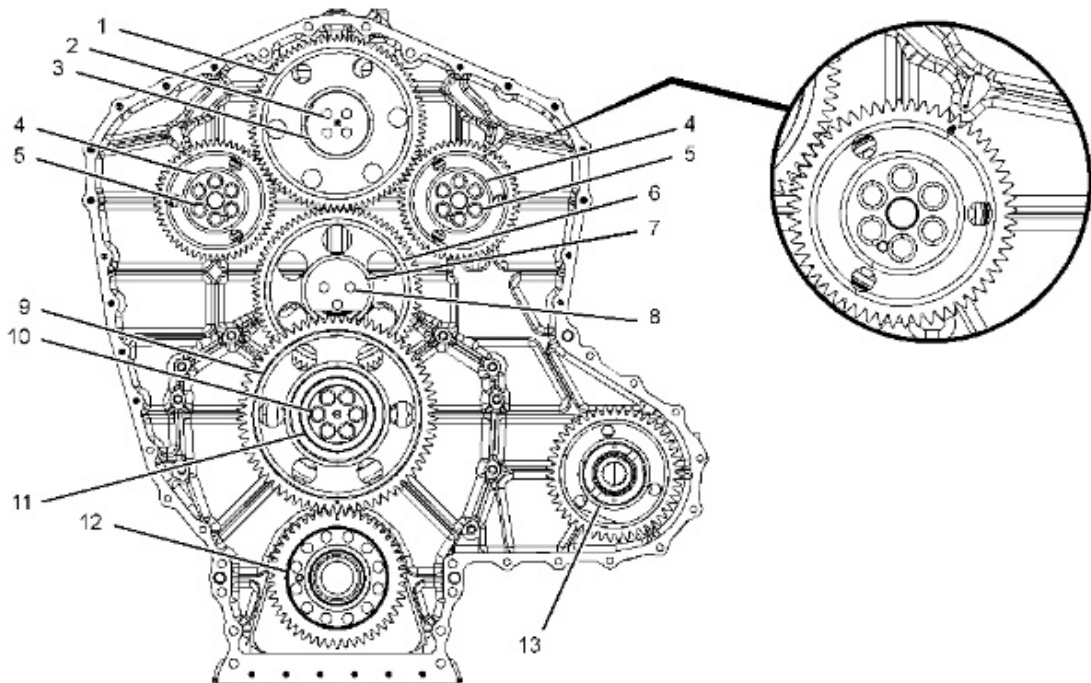

Illustration 12

g02739066

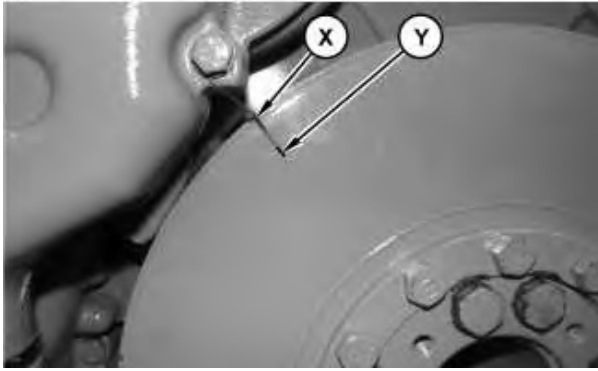

Illustration 13

g02087895

(X) Marker

(Y) Alignment Mark

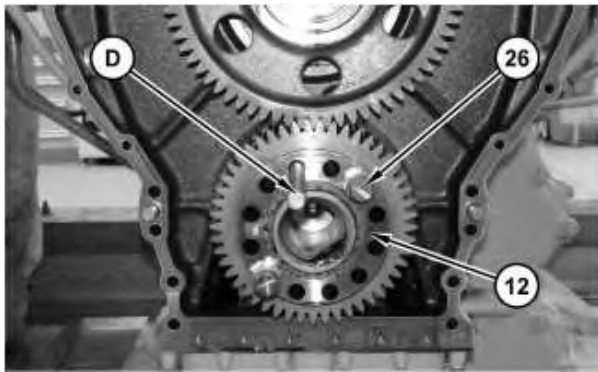

Illustration 14

g02739376

Note: Align the timing marks on gear assemblies (4) with the timing marks on the rear housing. Align the dowels on gear assemblies (4) with the adapter assemblies.

8. Position gear assemblies (4) and install bolts (5). Tighten bolts (5) to $240 \pm 40 \text{ N}\cdot\text{m}$ ($177 \pm 30 \text{ lb ft}$).
9. Install Tooling (D) in the crankshaft. Install gear assembly (12).
10. If the top center position is already marked on the vibration damper, proceed to Step 11.
 - a. Install the flywheel housing and the flywheel temporarily. Two bolts in the flywheel housing and the flywheel are sufficient.
 - b. Position the number one piston in the top center position (TC). The engine should be at the top center position in order to install the rear gear group. Refer to Testing and Adjusting, "Finding Top Center Position for No. 1 Piston".
 - c. With the number one piston in the top center position (TC), attach a marker to the engine and place an Alignment Mark on the vibration damper.
 - d. Remove the flywheel and the flywheel housing.
11. Install two nuts on two bolts (26) from the flywheel in gear assembly (12). The nuts will provide spacing when the bolts are installed.
12. Use Tooling (A) and a suitable press to install the bearing in gear assembly (1). Install the bearing to a depth of $2.6 \pm 0.5 \text{ mm}$ ($0.10 \pm 0.02 \text{ inch}$).

13. Install shaft assembly (3), gear assembly (1), and bolts (2).
14. Use Tooling (A) and a suitable press to install the bearing in gear assembly (6). Install the bearing to a depth of 2.6 ± 0.5 mm (0.10 ± 0.02 inch).
15. Install gear assembly (6), plate (7), and bolts (8).

Note: Install plate (7) with the side marked "OUT" away from the gear face.

16. Use Tooling (A) and a suitable press to install the bearing in gear assembly (9). Install the bearing to a depth of 3.2 ± 0.5 mm (0.13 ± 0.02 inch).

Note: Ensure that the number one piston is in the top center position (TC). Ensure that the timing marks on gear assemblies (4) are in alignment with the timing marks on the rear housing.

Note: Do not use the alignment marks found on gears (9) and (12). Doing so will create errors. Use the following steps to align gear (9).

17. Hold gear assembly (6) in the direction of normal engine rotation in order to remove the backlash. Place gear assembly (9) on the shaft assembly. The teeth on gear assembly (9) will engage with gear assembly (12) first. The teeth on gear assembly (9) will engage with the teeth on gear assembly (6) next. If the teeth on gear assembly (9) do not engage properly, turn the gear assembly to the next tooth and try again.
18. Install thrust plate (11) and bolts (10).
19. Turn the engine in the opposite direction of normal engine rotation for approximately 45 degrees. Turn the engine in the direction of normal engine rotation until the alignment mark on the vibration damper and the marker on the engine are aligned. Ensure that timing marks on gear assemblies (4) are in alignment with the marks on the rear housing.

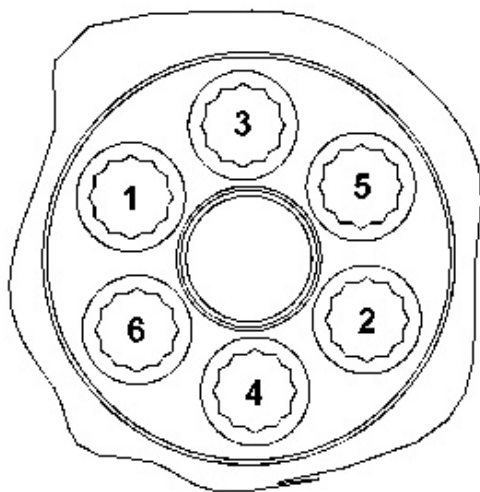

Illustration 15

g02739437

20. Tighten the bolts on gear assemblies (4) to a torque of 240 ± 40 N·m (177 ± 30 lb ft). Tighten using the above illustrated sequence. Tighten bolts illustrated as 1 and 2 an additional 240 ± 40 N·m (177 ± 30 lb ft).

End By:

- a. Install the flywheel housing. Refer to Disassembly and Assembly, "Flywheel Housing - Remove and Install".
-

Product: TRUCK

Model: 777G TRUCK T5A

Configuration: 777G OEM Off-Highway Truck T5A00001-UP (MACHINE) POWERED BY C32 Engine

Disassembly and Assembly C27 and C32 Engines for Caterpillar Built Machines

Media Number -KENR8148-13

Publication Date -01/09/2018

Date Updated -05/09/2018

i04586389

Flywheel - Remove and Install

SMCS - 1156-010

Removal Procedure

Table 1

Required Tools			
Tool	Part Number	Part Description	Qty
A	-	Guide Stud 5/8 - 18 UNF by 11 inch	2

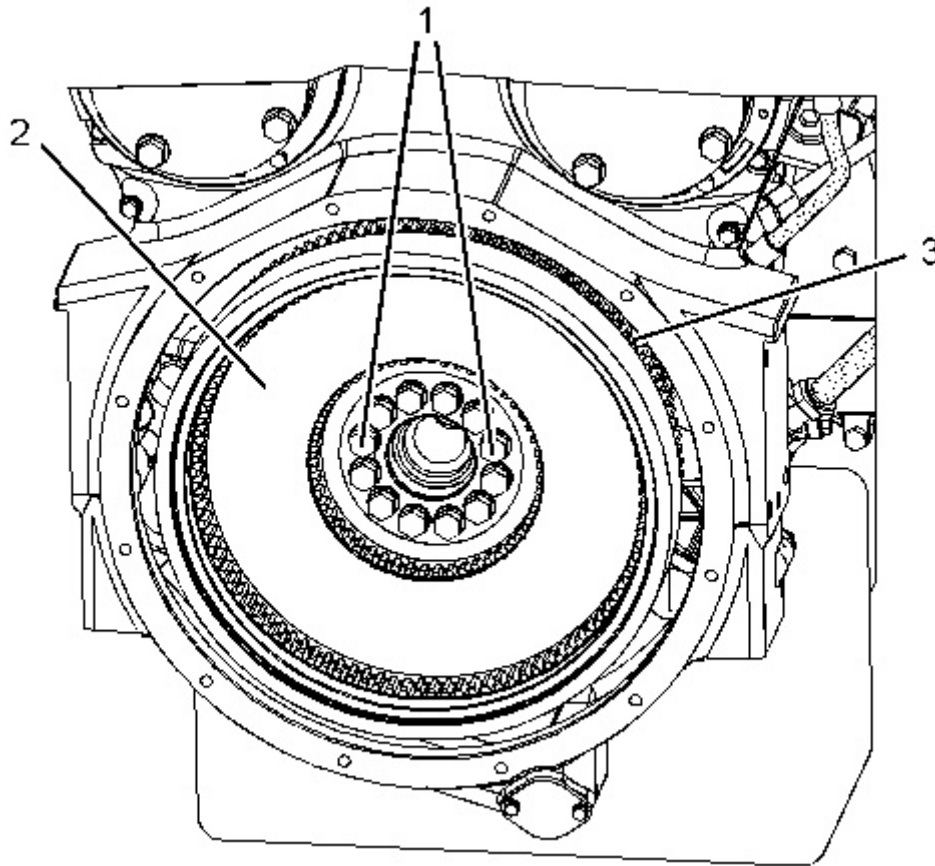

Illustration 1

g01146830

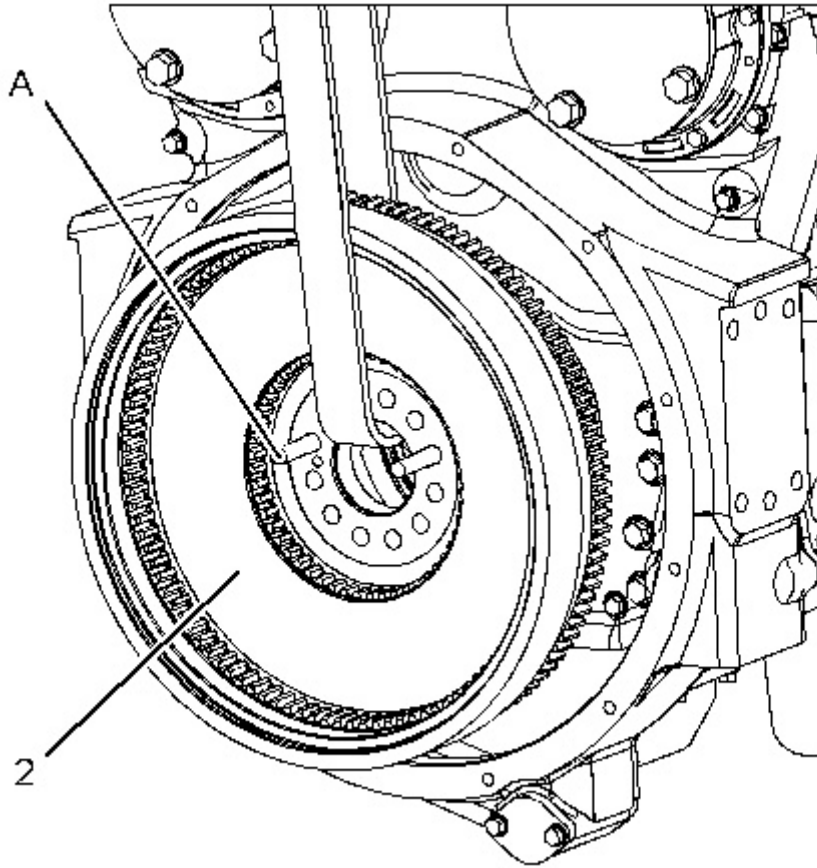

Illustration 2

g01146857

1. Remove two bolts (1). Install Tooling (A) in the crankshaft.
2. Remove remaining bolts (1). Slide flywheel (2) away from the engine on Tooling (A).
3. Attach a suitable lifting device to flywheel (2). The weight of flywheel (2) is approximately 120 kg (265 lb). Remove flywheel (2).
4. If necessary, use a hammer and a punch in order to remove ring gear (3) from flywheel (2).

Installation Procedure

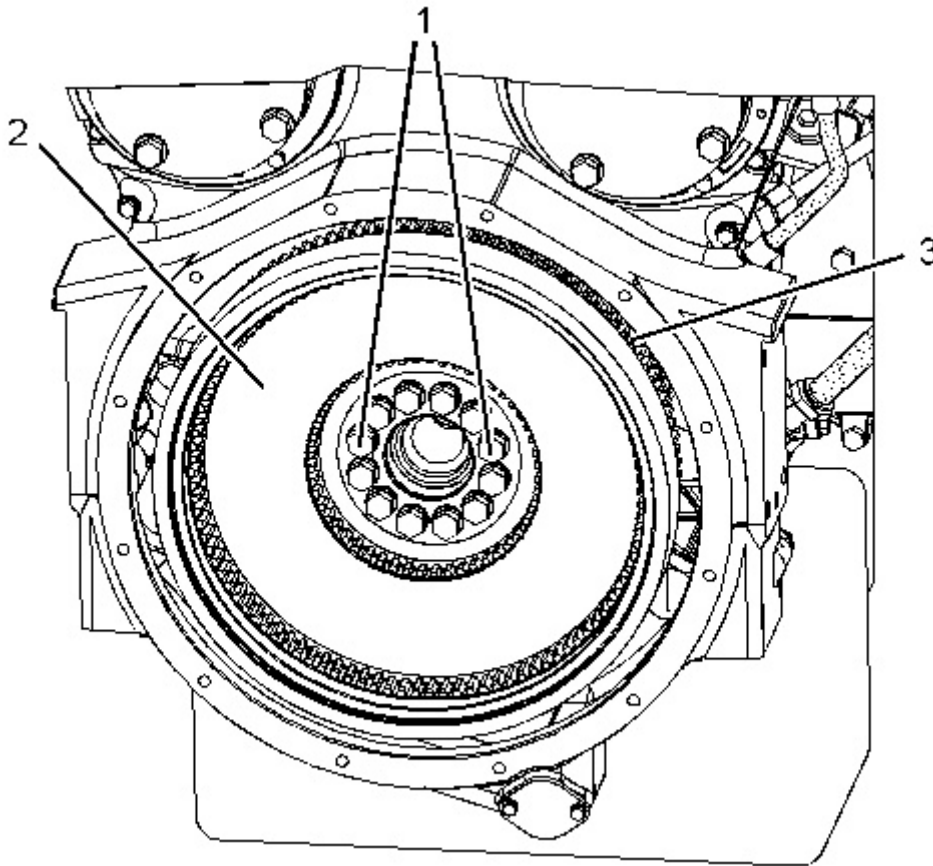

Illustration 3

g01146830

Note: Ring gear (3) must be installed with the chamfered side of the teeth upward. The chamfered side of the gear teeth will be facing toward the starting motor when the flywheel is installed.

1. Raise the temperature of ring gear (3). Install ring gear (3) on flywheel (2).
 2. Install Tooling (A) in the crankshaft.
 3. Attach a suitable lifting device to flywheel (2). The weight of flywheel (2) is approximately 120 kg (265 lb). Position flywheel (2) on the crankshaft.
 4. Apply clean engine oil to the threads of bolts (1).
 5. Install bolts (1). Remove Tooling (A). Install remaining bolts (1).
 6. Tighten bolts (1) to a torque of $270 \pm 40 \text{ N}\cdot\text{m}$ ($200 \pm 30 \text{ lb ft}$).
 7. Check the flywheel runout. Refer to Testing and Adjusting, "Flywheel - Inspect".
-

Product: TRUCK

Model: 777G TRUCK T5A

Configuration: 777G OEM Off-Highway Truck T5A00001-UP (MACHINE) POWERED BY C32 Engine

Disassembly and Assembly C27 and C32 Engines for Caterpillar Built Machines

Media Number -KENR8148-13

Publication Date -01/09/2018

Date Updated -05/09/2018

i07416060

Crankshaft Rear Seal - Remove and Install

SMCS - 1161-010

Removal Procedure

Table 1

Required Tools			
Tool	Part Number	Part Description	Qty
A	1U-7600	Slide Hammer Puller	1
B	-	Pry Bar	1
C	5P-7312	Seal Distorter	1
D	5P-7314	Distorter Ring	1
E	249-2937 ⁽¹⁾	Seal Locator As	1
	5P-7310 ⁽¹⁾	Bolt	3
	9S-8858 ⁽¹⁾	Nut (Seal Installer)	1
	6V-6143 ⁽¹⁾	Seal Installer	1
	5P-1733 ⁽²⁾	Seal Locator As	1
	5P-7309 ⁽²⁾	Bolt	3
	9S-8858 ⁽²⁾	Nut (Seal Installer)	1
	6V-6143 ⁽²⁾	Seal Installer	1

⁽¹⁾ Large pilot for crankshaft gear (approximately 85 mm (3.3 inch) diameter)

⁽²⁾ Small pilot for crankshaft gear (approximately 52 mm (2.0 inch) diameter)

Start By:

- a. Remove the flywheel.

Note: Ensure that the rear gear remains in place when the crankshaft rear seal and crankshaft wear sleeve are removed.

1. Install two bolts from the flywheel and suitable washers through the rear gear in the crankshaft.

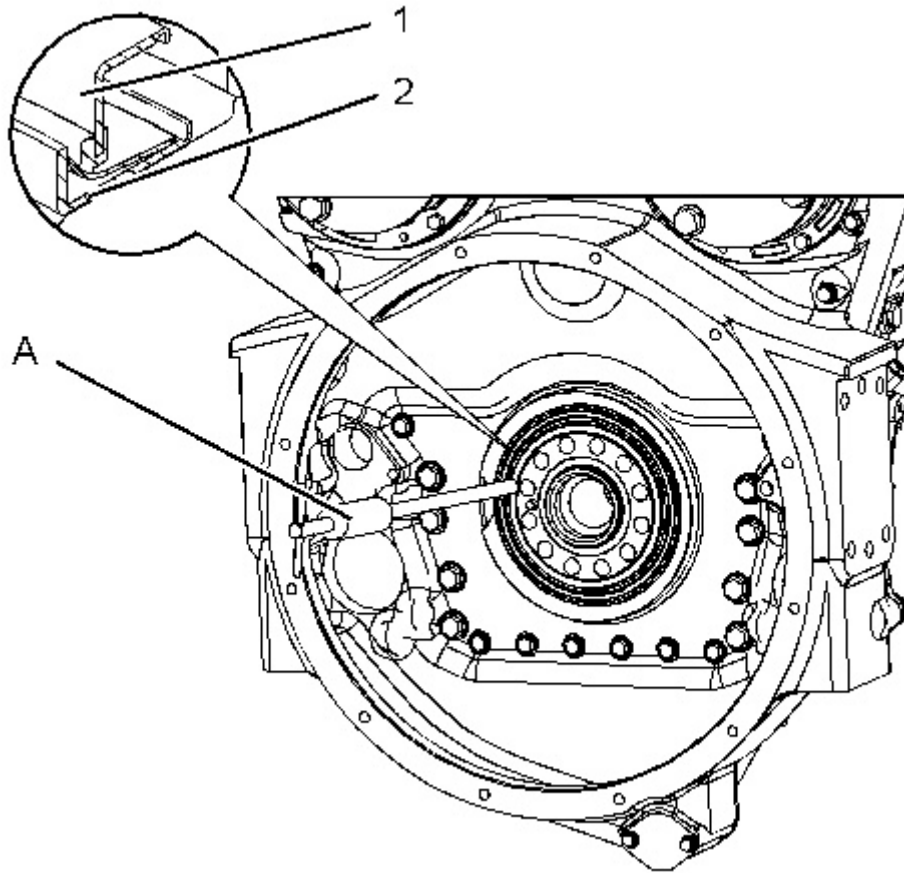

Illustration 1

g01146630

Note: Ensure that you do not damage the flywheel housing with Tooling (B).

Note: If the crankshaft wear sleeve starts to slide off the crankshaft, go to Step 3.

2. Use Tooling (B) to pry around the lip of crankshaft wear sleeve (2).
3. Use Tooling (A) or a punch and hammer in order to puncture three or more holes in crankshaft rear seal (1).
4. Use Tooling (A) to remove crankshaft rear seal (1).
5. If necessary, use Tooling (C) and Tooling (D) to remove crankshaft wear sleeve (2).

Installation Procedure

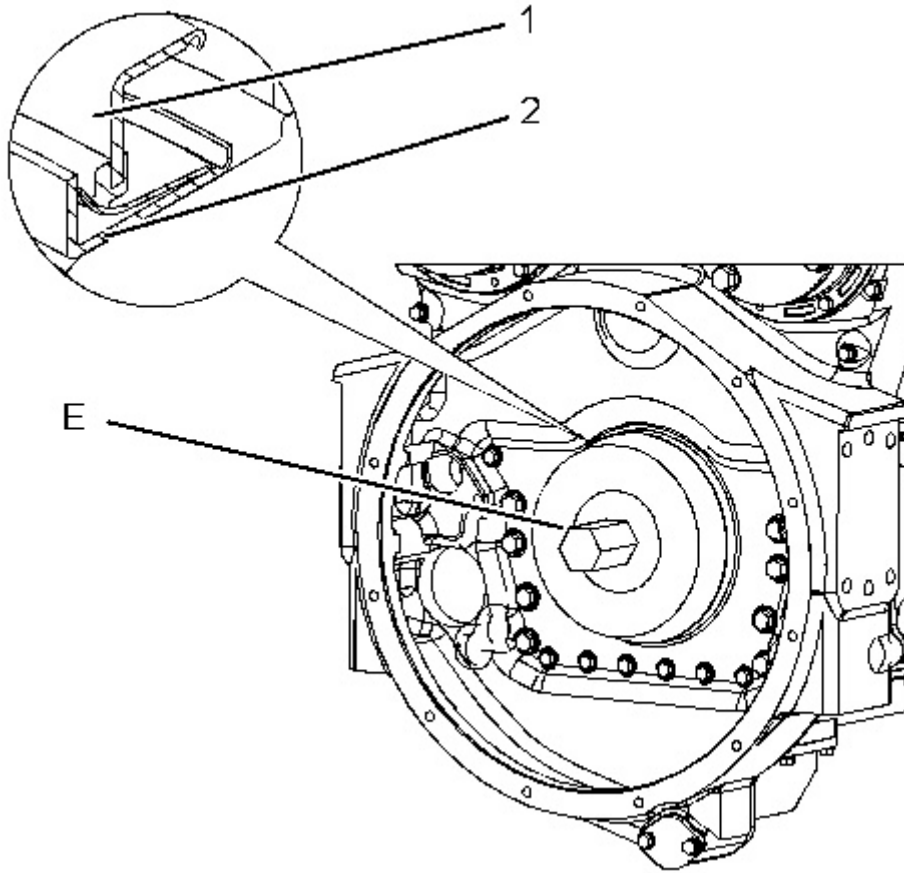

Illustration 2

g01513824

1. Clean the outside diameter of the crankshaft.

Note: Install the crankshaft rear seal with the arrow that shows the direction of crankshaft rotation toward the rear of the engine.

2. Use Tooling (E) to install crankshaft wear sleeve (2) and crankshaft rear seal (1) as a unit.

End By:

- a. Install the flywheel.
-

Product: TRUCK

Model: 777G TRUCK T5A

Configuration: 777G OEM Off-Highway Truck T5A00001-UP (MACHINE) POWERED BY C32 Engine

Disassembly and Assembly C27 and C32 Engines for Caterpillar Built Machines

Media Number -KENR8148-13

Publication Date -01/09/2018

Date Updated -05/09/2018

i07380582

Flywheel Housing - Remove and Install

SMCS - 1157-010

S/N - FHS1-UP

S/N - NHG1-UP

S/N - NHK1-UP

S/N - NHT1-UP

S/N - PHB1-UP

Removal Procedure

Table 1

Required Tools			
Tool	Part Number	Part Description	Qty
A	439-3939	Link Bracket	2
B	-	Guide Stud 1/2 - 13 NC by 5 inch	2

Start By:

- Remove the rear power take-off (RPTO). Refer to Disassembly and Assembly, "Rear Power Take-Off (RPTO) - Remove".
- Remove the crankshaft rear seal. Refer to Disassembly and Assembly, "Crankshaft Rear Seal - Remove".
- Remove the electric starting motor. Refer to Disassembly and Assembly, "Electric Starting Motor - Remove and Install".

NOTICE

Keep all parts clean from contaminants.

Contaminants may cause rapid wear and shortened component life.

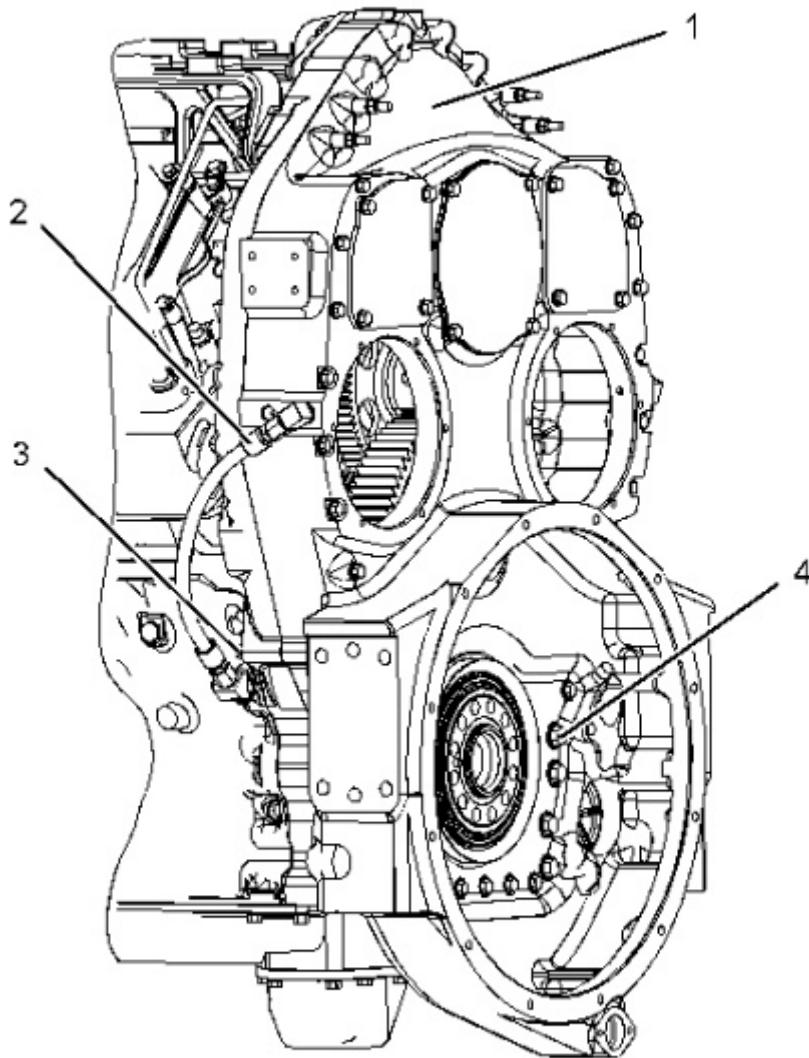

Illustration 1

g01265919

1. Disconnect hose assemblies (2) from flywheel housing (1).

2. Remove bolts (4) and install Tooling (B).
3. Attach Tooling (A) and a suitable lifting device to flywheel housing (1). The weight of flywheel housing (1) is approximately 145 kg (320 lb).
4. Remove remaining bolts (4) and bolts (3). Remove flywheel housing (1) and the gasket from the cylinder block.

Installation Procedure

Table 2

Required Tools			
Tool	Part Number	Part Description	Qty
A	439-3939	Link Bracket	2
B	-	Guide Stud 1/2 - 13 NC by 5 inch	2

NOTICE

Keep all parts clean from contaminants.

Contaminants may cause rapid wear and shortened component life.



Suggest:

For more complete manuals. Please go to the home page.

<https://www.ebooklibonline.com>

If the above button click is invalid. Please download this document first, and then click the above link to download the complete manual.

Thank you so much for reading

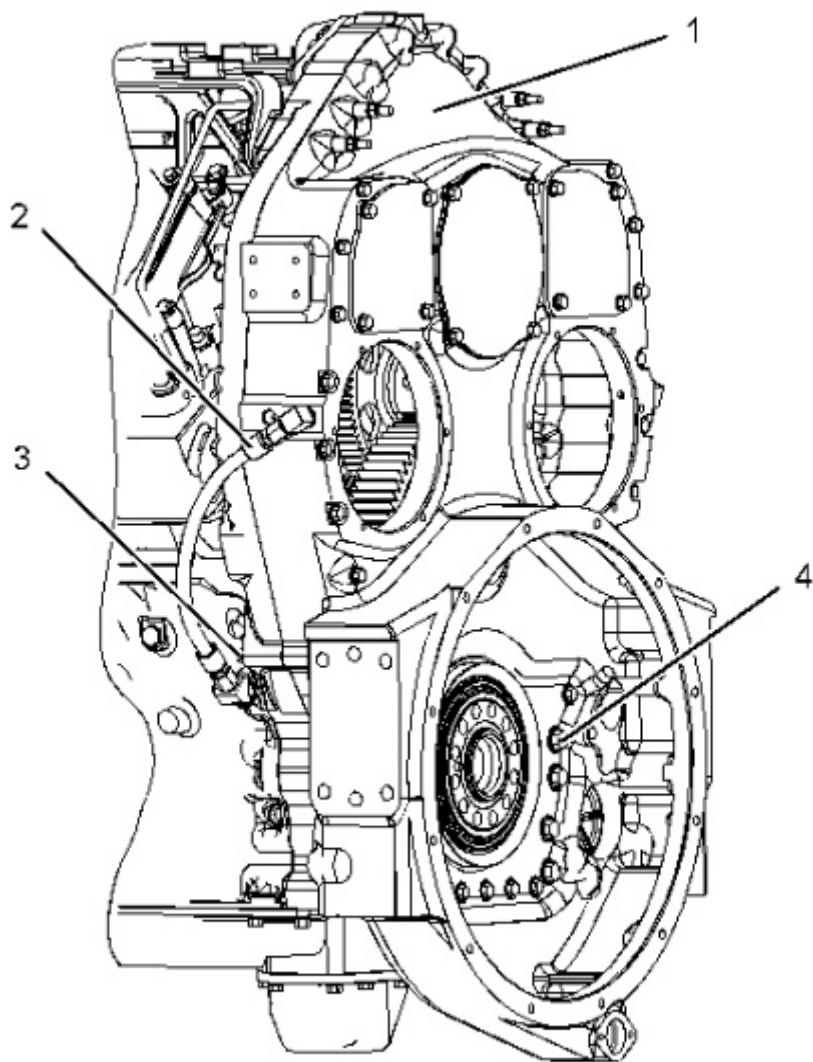

Illustration 2

g01265919

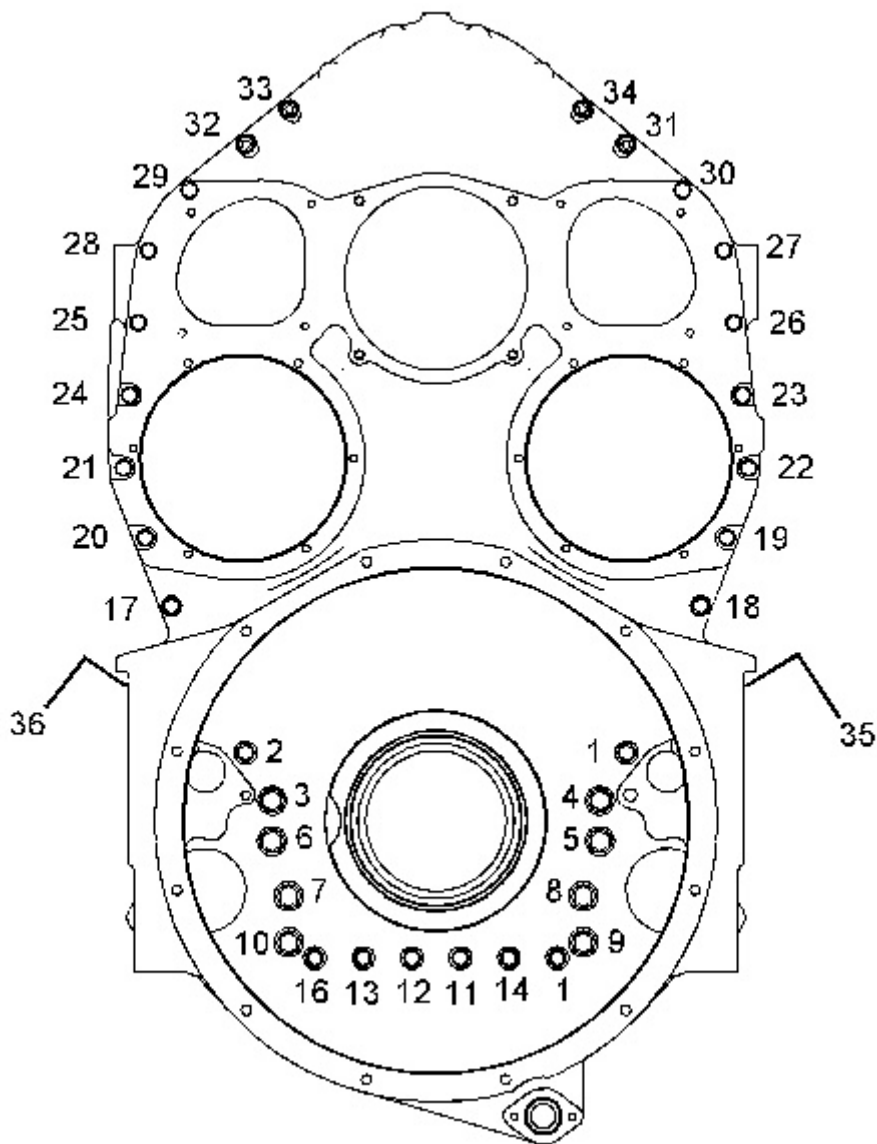

Illustration 3

g06301145

1. Install Tooling (B) in the cylinder block.
2. Attach Tooling (A) and a suitable lifting device to flywheel housing (1). The weight of flywheel housing (1) is approximately 145 kg (320 lb).
3. Position the gasket and flywheel housing (1) on the cylinder block. Install bolts (4) and bolts (3).
4. Remove Tooling (B) and install remaining bolts (4).
5. Tighten the bolts, as follows:
 - a. In a numerical sequence, tighten Bolt 1 through Bolt 2 to a torque of 55 ± 10 N·m (41 ± 7 lb ft).
 - b. In a numerical sequence, tighten Bolt 3 through Bolt 10 to a torque of 135 ± 20 N·m (100 ± 15 lb ft).

<https://www.ebooklibonline.com>

Hello dear friend!

Thank you very much for reading.

Enter the link into your browser.

The full manual is available for immediate download.

<https://www.ebooklibonline.com>