

Product: TRUCK

Model: 777G TRUCK T4Y

Configuration: 777G OEM Off-Highway Truck T4Y00001-UP (MACHINE) POWERED BY C32 Engine

Disassembly and Assembly 777G Off-Highway Truck Power Train

Media Number -KENR9931-06

Publication Date -01/09/2018

Date Updated -26/09/2018

i06996176

Torque Converter - Disassemble

SMCS - 3101-015

Disassembly Procedure

Table 1

Required Tools			
Tool	Part Number	Part Description	Qty
A	439-3940	Link Bracket	3
B	-	Forcing Bolt 5/8 - 11 By 3 inch	3
C	1P-2420	Transmission Repair Stand	1
D	-	Forcing Bolt 1/2 in - 13	2
	8B-7548	Push-Puller Tool Group	1
E	8B-7550	Push-Puller Leg	2
	8B-7559	Adapter	2
F	1P-0520	Driver Group	1
	1P-0074	Slide Hammer Puller	1
G	5F-7342	Adapter	1
	8B-7554	Bearing Cup Puller	1
H	138-7573	Link Bracket	2
J	4F-7226	Bolt	2
K	138-7574	Link Bracket	2

L	2P-8312	Retaining Ring Pliers	1
M	-	Forcing Screws 3/8 in - 16	2
N	2D-1201	Eyebolt	1

Start By:

- a. Remove the torque converter. Refer to Disassembly and Assembly, "Torque Converter - Remove".

NOTICE

Care must be taken to ensure that fluids are contained during performance of inspection, maintenance, testing, adjusting, and repair of the product. Be prepared to collect the fluid with suitable containers before opening any compartment or disassembling any component containing fluids.

Refer to Special Publication, NENG2500, "Dealer Service Tool Catalog" for tools and supplies suitable to collect and contain fluids on Cat® products.

Dispose of all fluids according to local regulations and mandates.

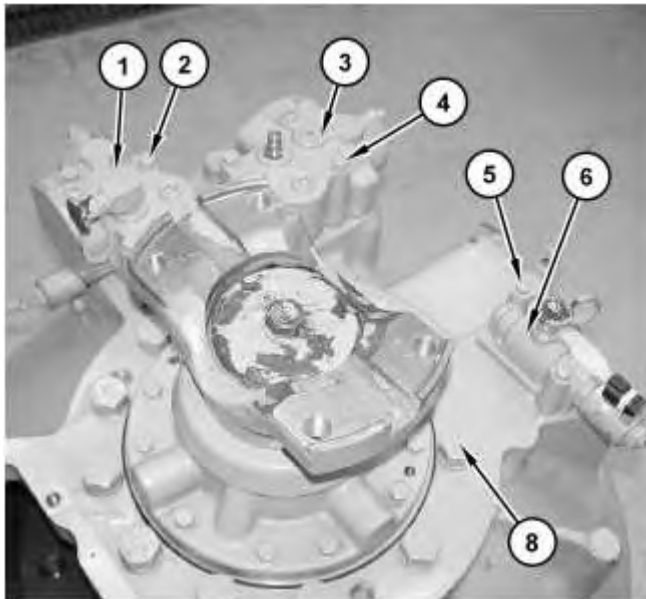

Illustration 1

g01825833

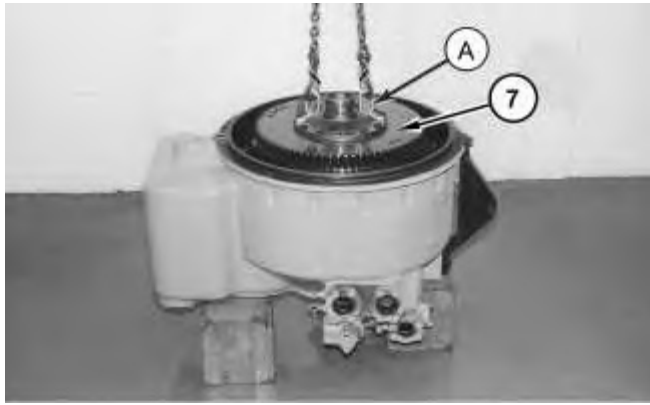

Illustration 2

g01322806

1. Remove bolts (2) and outlet relief valve (1). Remove bolts (4) and inlet relief valve (3). Remove bolts (5) and solenoid valve (6).
2. Position the torque converter housing onto suitable blocks, as shown. Attach Tooling (A) and a suitable lifting device to torque converter (7). The weight of torque converter (7) is approximately 362 kg (800 lb). Remove bolts (8) and torque converter (7).



Illustration 3

g01321926

3. Position the torque converter onto Tooling (C). Remove plug (10) and plug orifice (13) from clutch carrier (9).
4. Remove bolts (11) and remove the washers that hold flywheel pilot (12) in position.
5. Use Tooling (D) (not shown) in order to separate flywheel pilot (12) from clutch carrier (9). Remove flywheel pilot (12) from clutch carrier (9).

<https://www.ebooklibonline.com>

Hello dear friend!

Thank you very much for reading.

Enter the link into your browser.

The full manual is available for immediate download.

<https://www.ebooklibonline.com>

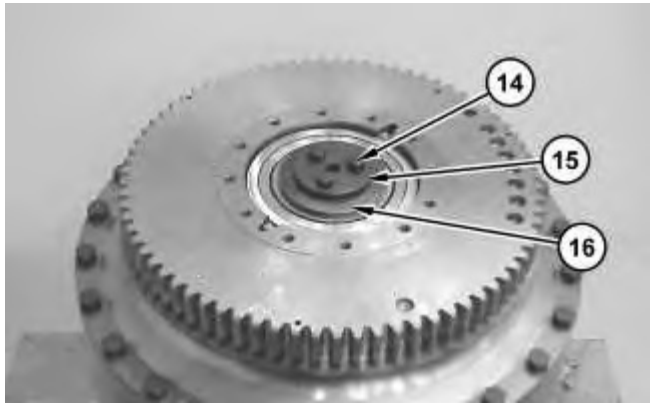

Illustration 4

g01321941

6. Remove bolts (14) and retainer plate (15) from the output shaft.
7. Remove spring washer (16).

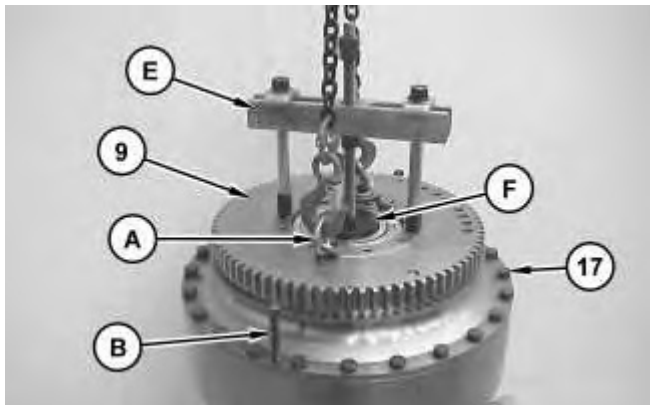

Illustration 5

g01321967

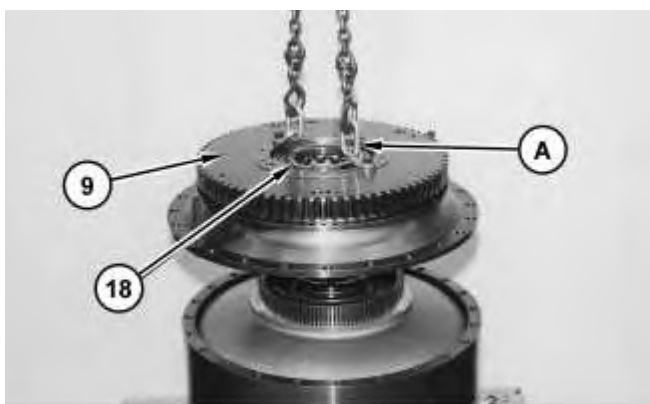

Illustration 6

g01321976

8. Attach Tooling (A) and a suitable lifting device to clutch carrier (9). The weight of clutch carrier (9) is approximately 104 kg (230 lb). Remove bolts (17).

9. Install Tooling (B). Install Tooling (E) and Tooling (F). Apply slight tension on the suitable lifting device as Tooling (B) is tightened.
10. Apply a downward force on Tooling (E). Apply an upward force on the lifting device in order to remove clutch carrier (9).
11. Remove Tooling (E) and Tooling (F). Remove clutch carrier (9). Remove top half of bearing (18).
12. Refer to the following procedure in order to disassemble clutch carrier (9):



Illustration 7

g01322007

- a. Remove bolts (20) and split washers (19).

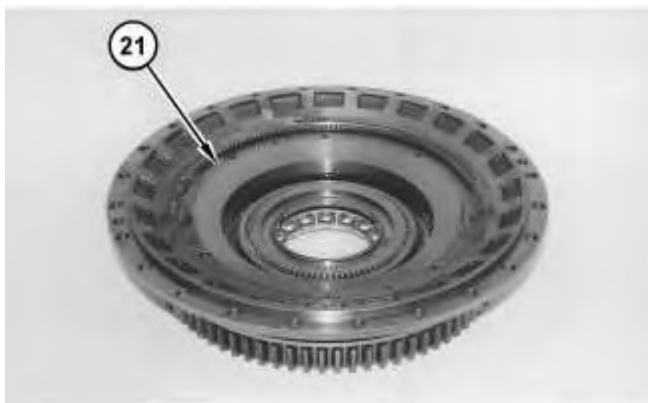

Illustration 8

g01322008

- b. Remove backing plate (21).
-

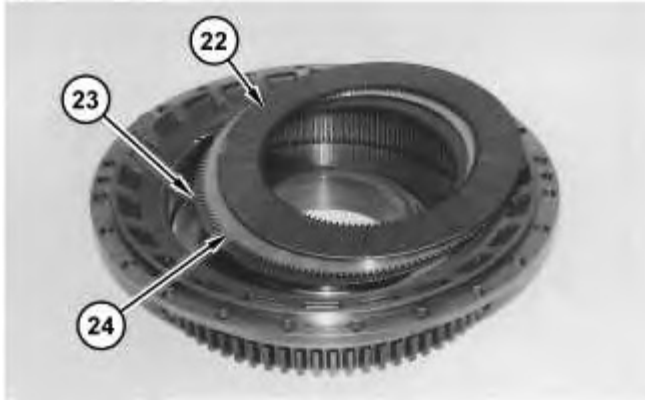

Illustration 9

g01322013

- c. Remove friction discs (22) and (23). Remove clutch plate (24).

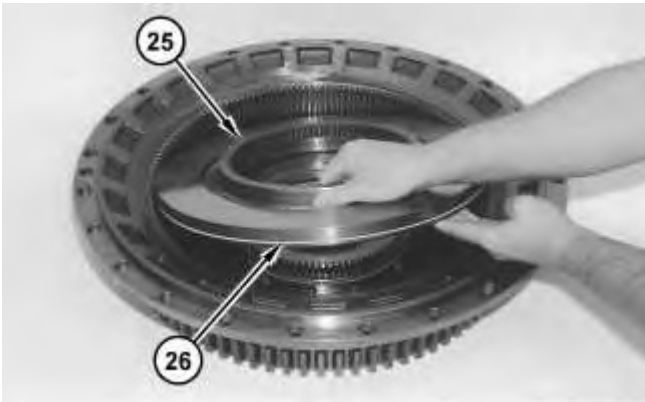

Illustration 10

g01322084

- d. Remove lockup clutch piston (25) and seal ring (26).

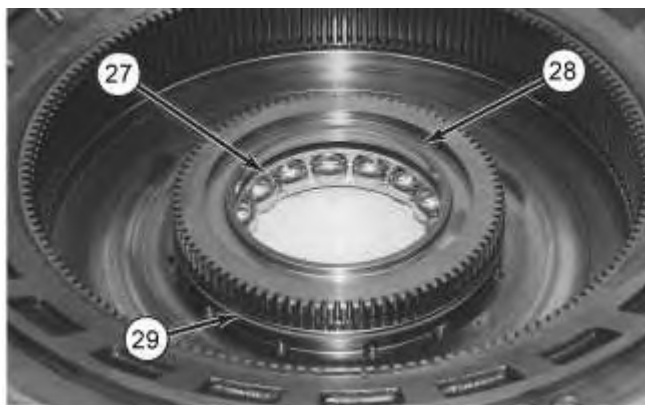

Illustration 11

g01322099

- e. Remove seal ring (28) and ball bearing (27). Remove wear sleeve (29).

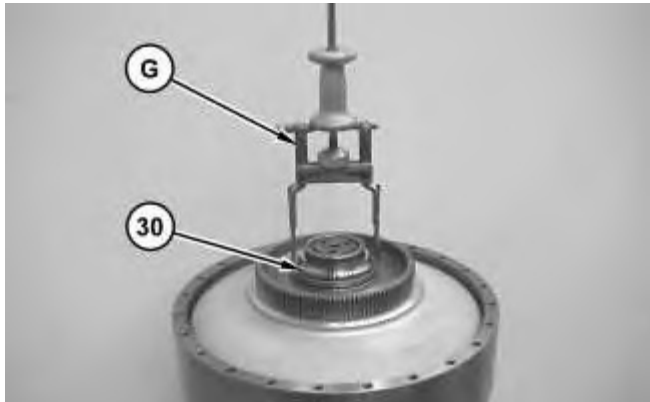

Illustration 12

g01322101

13. Use Tooling (G) in order to remove the bottom half of inner bearing race (30).

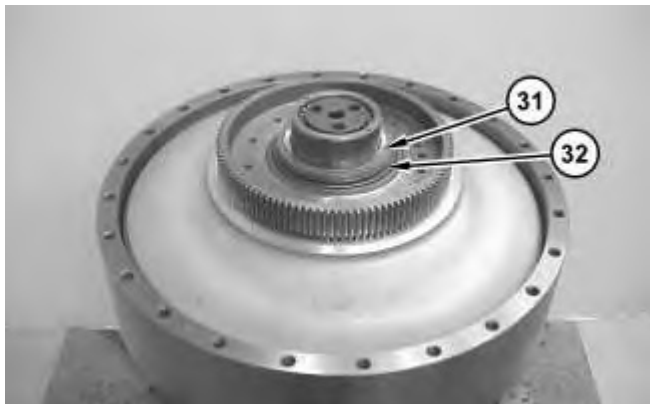

Illustration 13

g01322102

14. Remove ring carrier (31). Remove seal ring (32) from the ring carrier.

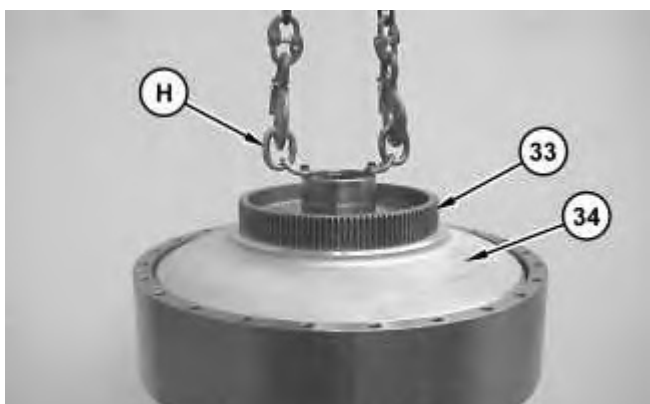

Illustration 14

g01322108

15. Attach Tooling (H) and a suitable lifting device to clutch hub (33) and turbine (34). The weight of clutch hub (33) and turbine (34) is approximately 36 kg (80 lb).
16. Remove clutch hub (33) and turbine (34) as a unit.

17. Refer to the following procedure in order to disassemble clutch hub (33) and turbine (34):



Illustration 15

g01322121

- a. Place the clutch hub and the turbine on suitable cribbing. Remove bolts (35).

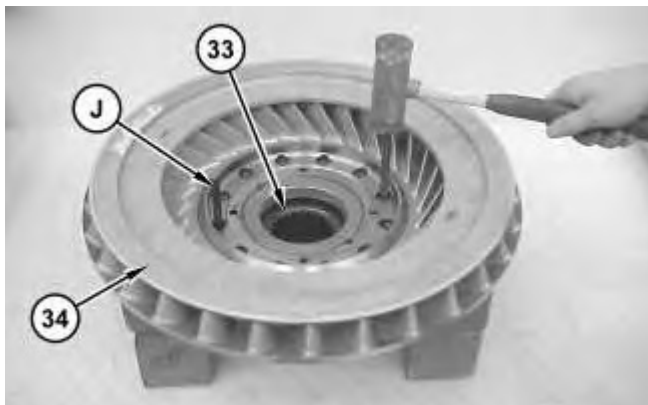

Illustration 16

g01322131

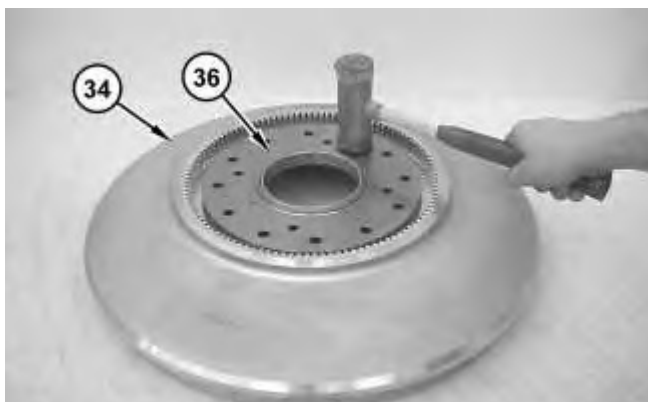

Illustration 17

g01322176

- b. Tooling (J) must be modified in order to be used as guide bolts. Position Tooling (J) in a suitable vise (not shown). Remove the heads of the bolts.

- c. Install Tooling (J) into clutch hub (33), as shown. Apply a downward force on the guide bolts in order to remove clutch hub (33). Turn over turbine (34). Remove hub assembly (36) from turbine (34).

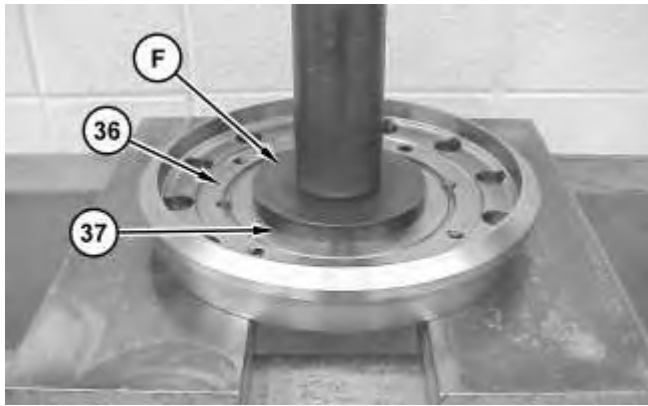

Illustration 18

g01322178

- d. Position hub assembly (36) and Tooling (F) in a suitable press. Remove sleeve bearing (37) (not shown) from hub assembly (36) by using the suitable press and Tooling (F).



Illustration 19

g01322188

18. Remove sleeve (38) and thrust race (39) from stator assembly (40).
19. Remove stator assembly (40).

Note: The rollers inside stator assembly (40) are free to move when the stator assembly is removed.

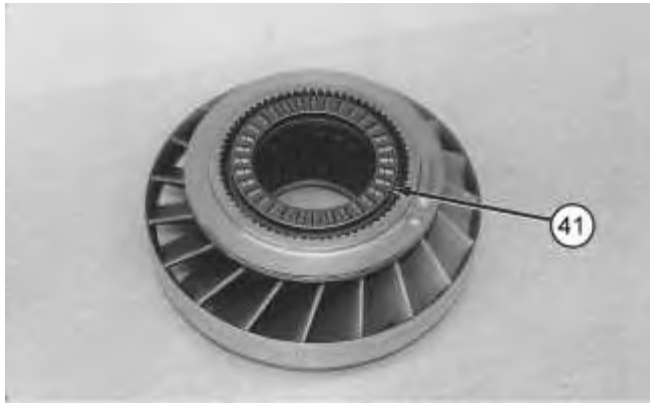

Illustration 20

g01322199

20. Refer to the following procedure in order to disassemble the stator assembly:

- a. Remove thrust bearing (41).

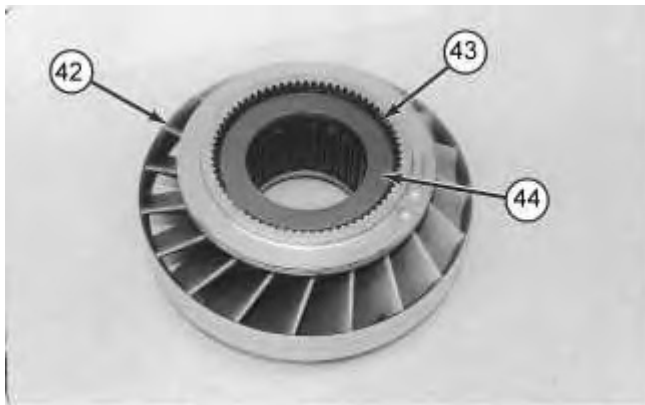

Illustration 21

g01322201

- b. Remove top retaining ring (43) and side plate (44) from stator (42). Remove the bottom retaining ring (not shown).

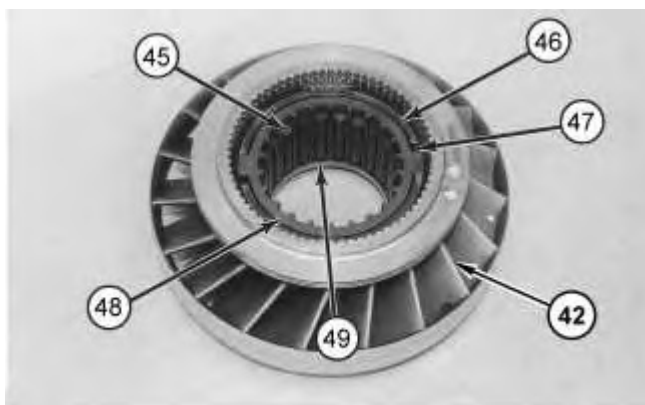

Illustration 22

g01322202

- c. Remove roller cage (48) with freewheel rollers (45) and springs (47) from freewheel cam (46).
- d. Remove freewheel rollers (45) and springs (47) from roller cage (48).
- e. Remove side plate (49) and freewheel cam (46) from stator (42).

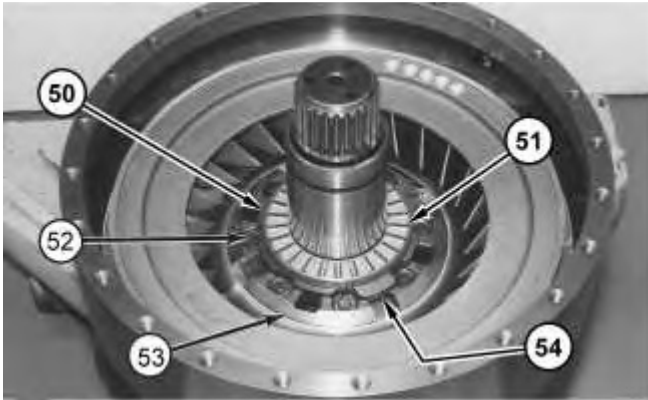

Illustration 23

g01322203

21. Remove sleeve (50), thrust bearing (51), and thrust race (53) (not shown) from impeller hub assembly (54).
22. Remove bolts (52) from impeller hub assembly (54). Remove impeller hub assembly (54).



Illustration 24

g01322209

23. Remove bolts (55) and the washers that hold the impeller to the housing.
-



Illustration 25

g01322213

24. Remove impeller (56).

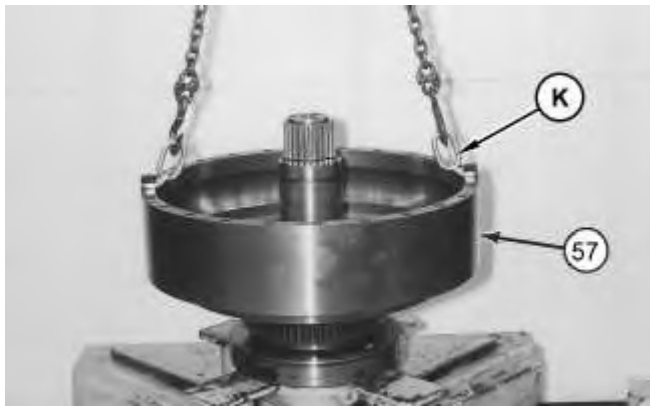

Illustration 26

g01322216

25. Attach Tooling (K) and a suitable lifting device to rotating housing (57). The weight of rotating housing (57) is approximately 82 kg (180 lb).

26. Remove rotating housing (57).



Illustration 27

g01322219

27. Refer to the following procedure in order to disassemble the rotating housing:

- a. Remove bolts (58).
- b. Remove pump drive gear (59).
- c. Remove wear sleeve (60) by using a hammer and a punch.

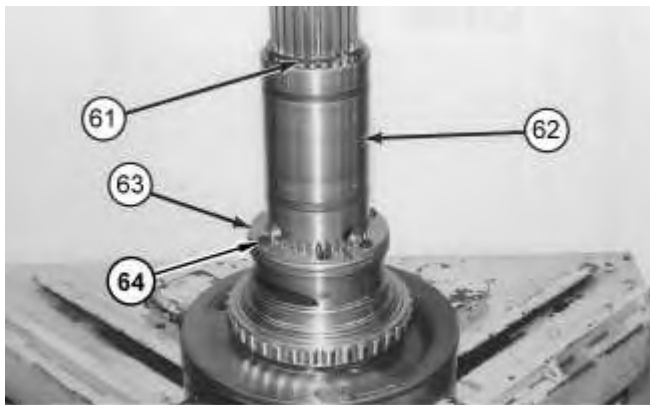

Illustration 28

g01322222

28. Use Tooling (L) in order to remove retaining ring (61).
29. Remove bolts (64) and split washers (63).
30. Remove freewheel race (62).

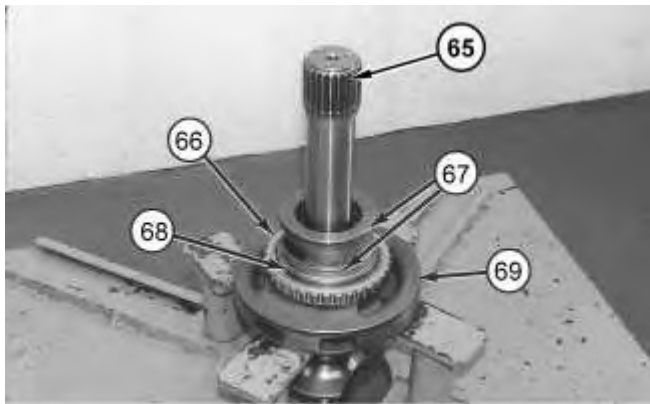

Illustration 29

g01322223

31. Remove seal rings (67) from stator carrier (69).
 32. Use Tooling (L) (not shown) in order to remove retaining ring (68).
 33. Remove inner bearing (66) from stator carrier (69).
 34. Attach Tooling (A) (not shown) and a suitable lifting device to output shaft (65).
 35. Remove output shaft (65) and the other components as an assembly. The weight of output shaft assembly (65) is approximately 73 kg (160 lb).
-

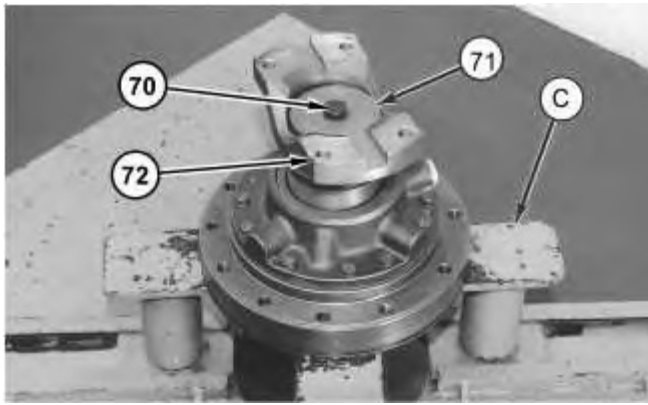

Illustration 30

g01322224

36. Attach Tooling (K) (not shown) and a suitable lifting device to yoke (72). Lift the yoke and place the assembly in Tooling (C), as shown.
37. Remove bolt (70) and shaft retainer (71).

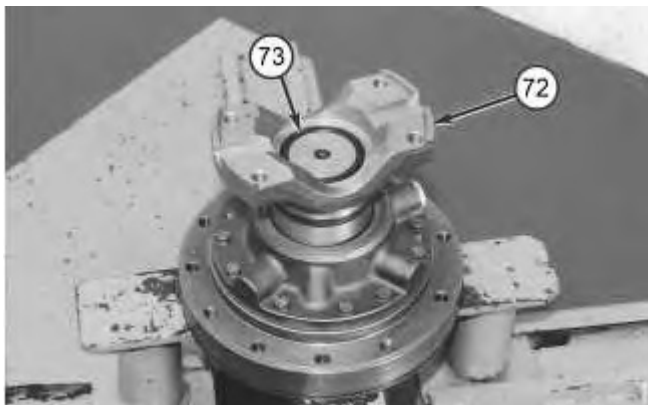

Illustration 31

g01322226

38. Remove O-ring seal (73) and yoke (72).

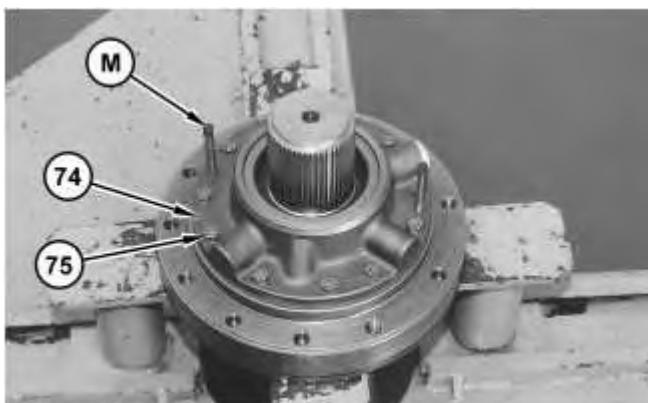

Illustration 32

g01322259

39. Install Tooling (M) in fluid distributor (74).

40. Remove bolts (75) and remove fluid distributor (74).



Illustration 33

g01322261

41. Remove lip seal (76) from fluid distributor (74).

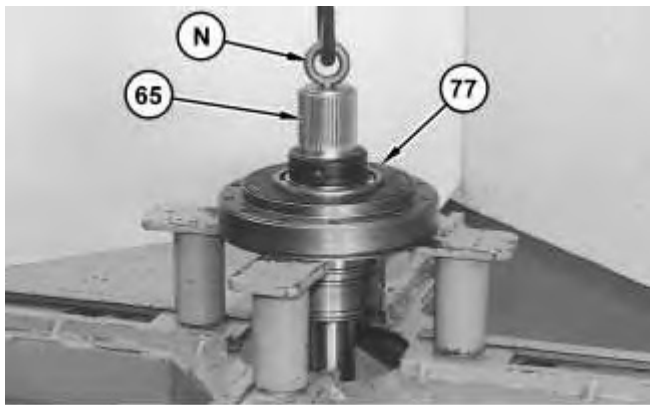

Illustration 34

g01322264

42. Attach Tooling (N) and a suitable lifting device to output shaft (65).

43. Remove output shaft (65) and remove flat gasket (77).



Illustration 35

g01322269

44. Remove seal rings (79) from ring carrier (78). Remove seal ring (82) from ring carrier (81).

45. Remove ring carrier (81), ball bearing (80), and ring carrier (78).

Product: TRUCK

Model: 777G TRUCK T4Y

Configuration: 777G OEM Off-Highway Truck T4Y00001-UP (MACHINE) POWERED BY C32 Engine

Disassembly and Assembly 777G Off-Highway Truck Power Train

Media Number -KENR9931-06

Publication Date -01/09/2018

Date Updated -26/09/2018

i07358548

Torque Converter - Assemble

SMCS - 3101-016

Assembly Procedure

Table 1

Required Tools			
Tool	Part Number	Part Description	Qty
A	439-3940	Link Bracket	2
C	1P-2420	Transmission Repair Stand	1
F	1P-0520	Driver Group	1
H	138-7573	Link Bracket	2
J	4F-7226	Bolt	2
K	138-7574	Link Bracket	2
L	2P-8312	Retaining Ring Pliers	1
N	2D-1201	Eyebolt	1
P	1P-0808	Multipurpose Grease	1
R	8S-9191	Bolt	2
S	1P-0808	Multipurpose Grease	1
T	4F-7226	Bolt	2
U	6V-4876	Lubricant	1

Note: Check all the O-ring seals and the components for wear or for damage. Replace the components, if necessary. Lubricate all the O-ring seals lightly with the lubricant that is being sealed. Clean all the components with a cloth that is free of loose material (lint).

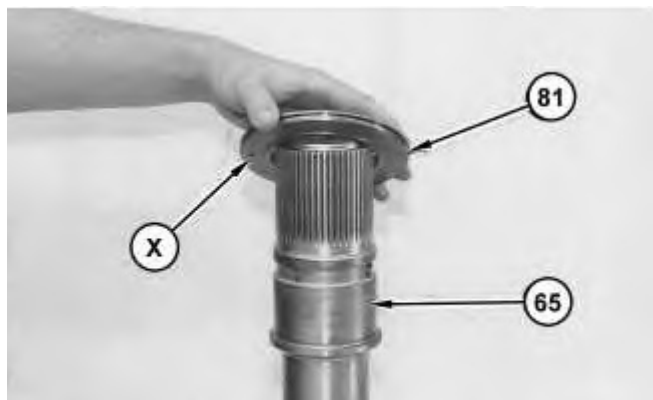

Illustration 1

g01322307

1. Install ring carrier (81) on output shaft (65) with the counterbore of hole (X) in the downward position.

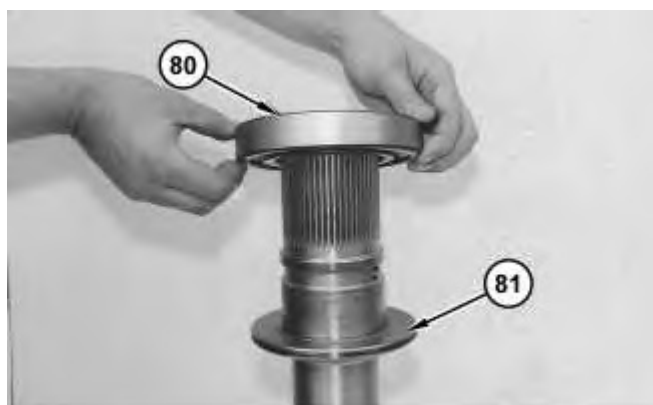

Illustration 2

g01322311

2. Install ball bearing (80) on top of ring carrier (81).



3. Install ring carrier (78) on top of ball bearing (80).

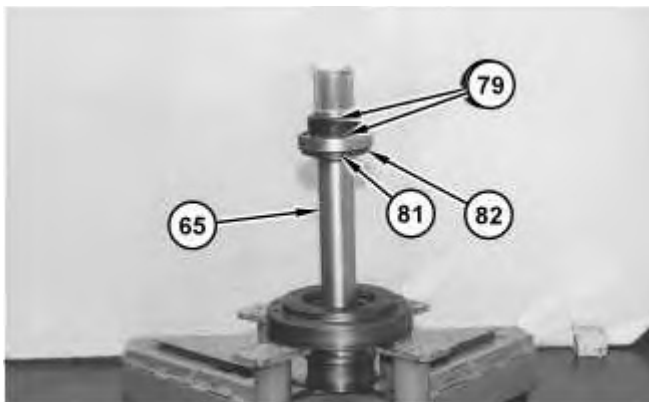

Illustration 4

4. Install seal rings (79) on ring carrier (78). Install seal ring (82) on ring carrier (81). Make sure that the ends of the seal rings are engaged.
5. Attach Tooling (N) (not shown) and a suitable lifting device to output shaft assembly (65). Install output shaft assembly (65).

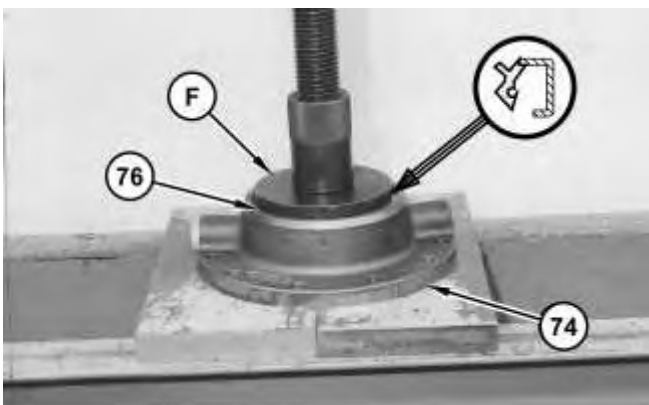

Illustration 5

6. Use Tooling (F) to install a new lip seal (76) in fluid distributor (74). Install the lip seal with the lips toward the inside.
-

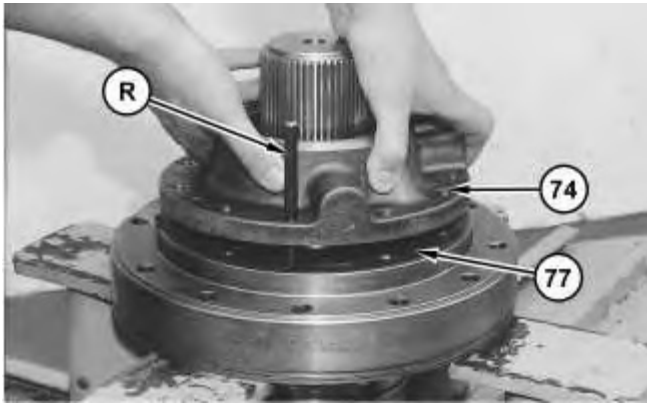

Illustration 6

g01322326

7. Tooling (R) must be modified to be used as guide bolts. Position Tooling (R) in a suitable vise (not shown). Remove the heads of the bolts.
8. Install Tooling (R) in the stator carrier. Install a new flat gasket (77). Install fluid distributor (74).

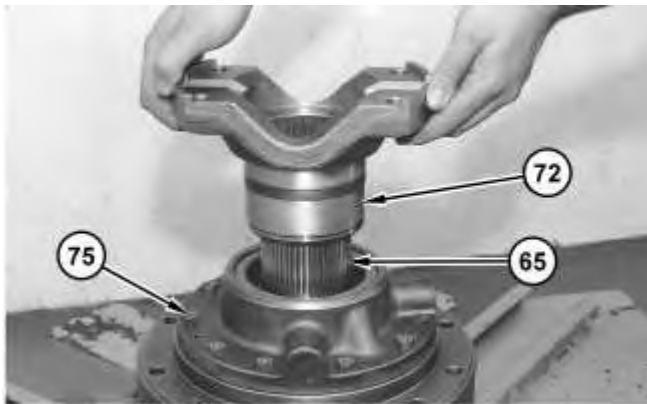

Illustration 7

g01322333

9. Install bolts (75). Tighten bolts (75) to a torque of 50 ± 7 N·m (37 ± 5 lb ft).
10. Install yoke (72) on the splines of output shaft (65).

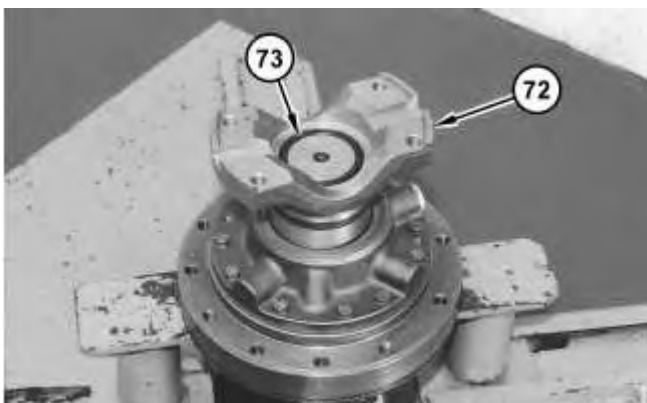

Illustration 8

g01322341



Suggest:

For more complete manuals. Please go to the home page.

<https://www.ebooklibonline.com>

If the above button click is invalid. Please download this document first, and then click the above link to download the complete manual.

Thank you so much for reading

11. Install O-ring seal (73) on yoke (72).

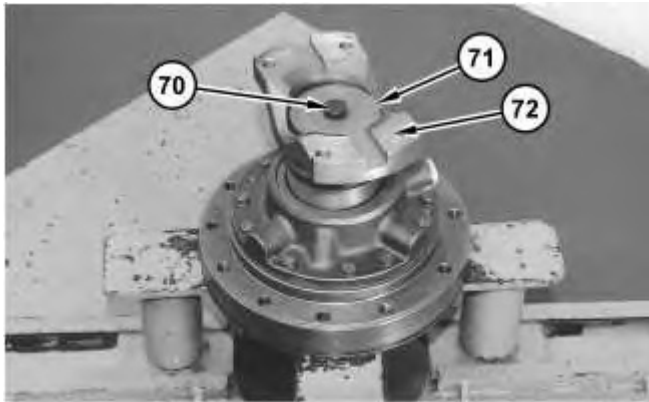

Illustration 9

g01322348

12. Install shaft retainer (71) and install bolt (70) that holds the shaft retainer in place. Tighten bolt (70) to a torque of $240 \pm 25 \text{ N}\cdot\text{m}$ ($177 \pm 18 \text{ lb ft}$).
13. Attach Tooling (K) (not shown) and a suitable lifting device to yoke (72).
14. Lift yoke (72) and the other components as a single unit. The weight of the assembly is approximately 73 kg (160 lb). Lay the assembly on a flat surface.

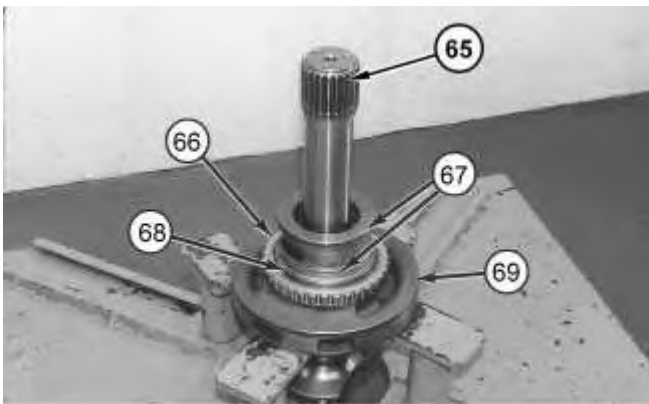
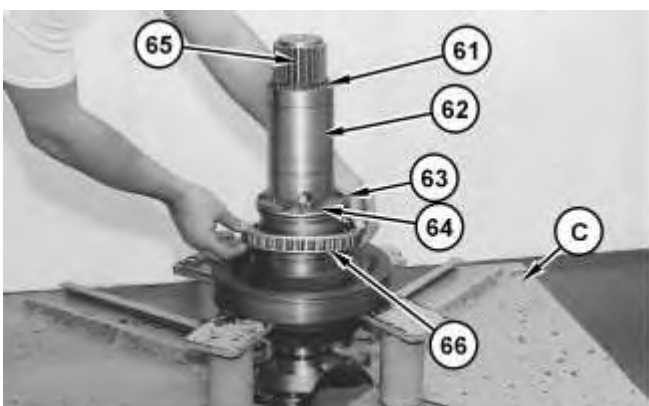

Illustration 10

g01322223



15. Attach Tooling (A) (not shown) and a suitable lifting device to output shaft (65).
16. Lift output shaft (65) and the other components as an assembly. Place the assembly in Tooling (C), as shown.
17. Install freewheel race (62) on output shaft (65).
18. Install split washers (63) and bolts (64).
19. Use Tooling (L) (not shown) to install retaining ring (61).
20. Install inner bearing (66) onto stator carrier (69) with the large inner radius in a downward position. Install seal rings (67).
21. Use Tooling (L) (not shown) to install retaining ring (68) on top of inner bearing (66).

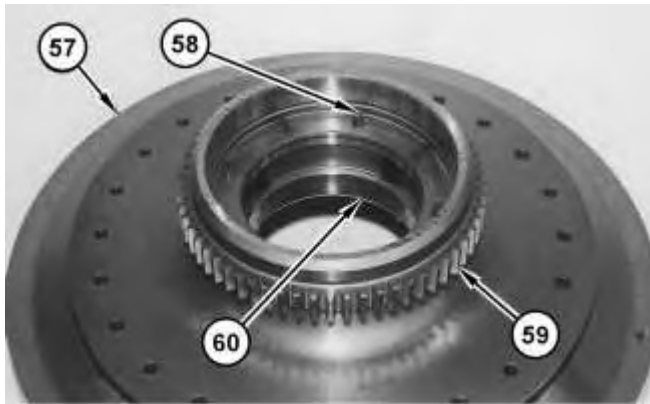

Illustration 12

22. Install pump drive gear (59) on rotating housing (57).
 23. Install bolts (58). Tighten bolts (58) to a torque of $50 \pm 7 \text{ N}\cdot\text{m}$ ($37 \pm 5 \text{ lb ft}$).
 24. Attach Tooling (K) (not shown) and a suitable lifting device to rotating housing (57). The weight of rotating housing (57) is approximately 82 kg (180 lb).
 25. Invert rotating housing (57).
 26. Install wear sleeve (60) on rotating housing (57).
-

<https://www.ebooklibonline.com>

Hello dear friend!

Thank you very much for reading.

Enter the link into your browser.

The full manual is available for immediate download.

<https://www.ebooklibonline.com>