

Product: TRUCK

Model: 777B TRUCK 4YC

Configuration: 776B TRACTOR & 777B TRUCK 4YC00001-UP (MACHINE) POWERED BY 3508 ENGINE

Disassembly and Assembly

3500 and 3500B High Displacement Engines for Caterpillar Built Machines

Media Number -SEN1126-33

Publication Date -01/07/2015

Date Updated -14/09/2018

i02429716

Engine Oil Cooler - Install

SMCS - 1378-012

Installation Procedure

NOTICE

Keep all parts clean from contaminants.

Contaminants may cause rapid wear and shortened component life.

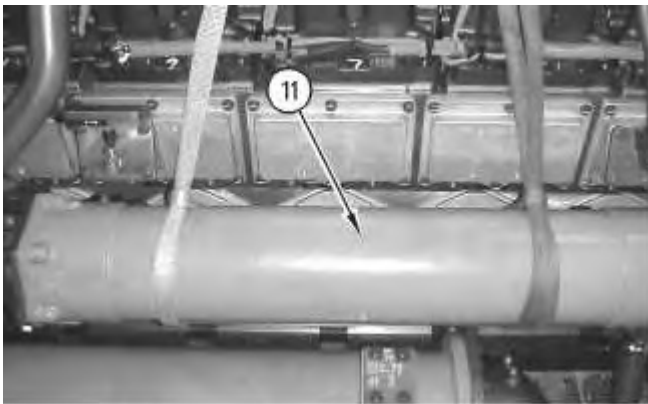

Illustration 1

g00916150

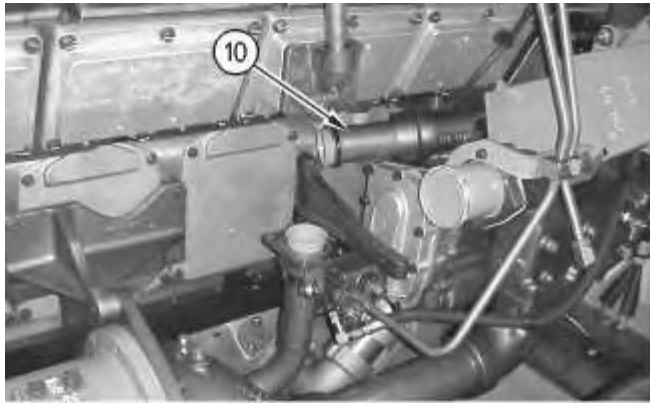

Illustration 2

g00915024

1. Install a suitable lifting device onto engine oil cooler (11). The weight of engine oil cooler (11) is approximately 95 kg (210 lb).
2. Slide engine oil cooler (11) into tube assembly (10).

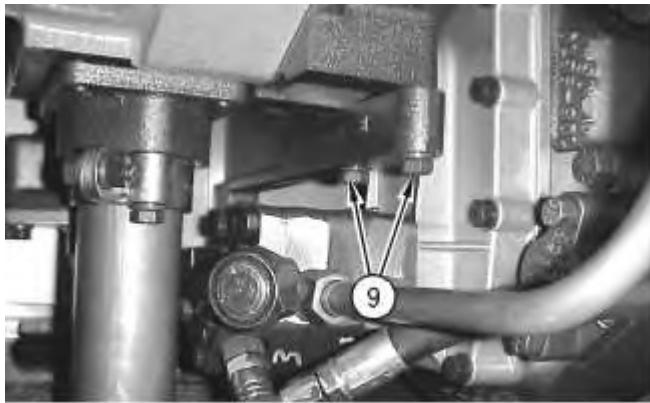

Illustration 3

g00915021

3. Install mount bolts (9).

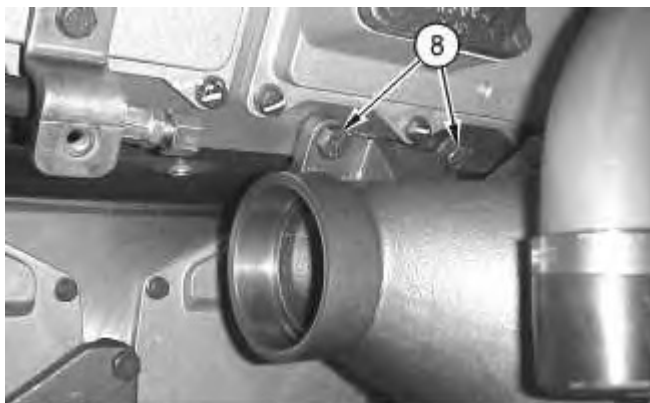

Illustration 4

g00915012

4. Install mount bolts (8) into the rear of the engine oil cooler.

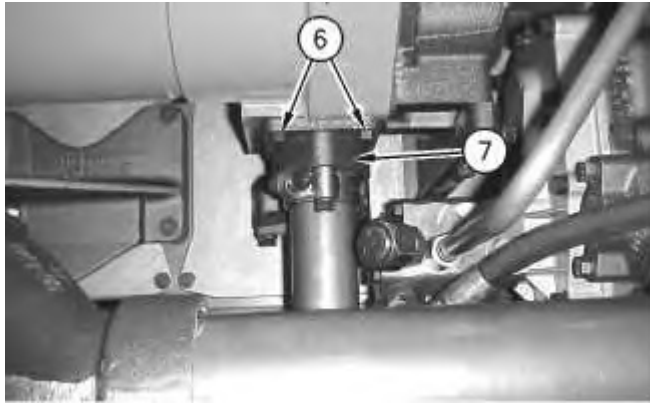

Illustration 5

g00914993

5. Install bolts (6) into flange (7).

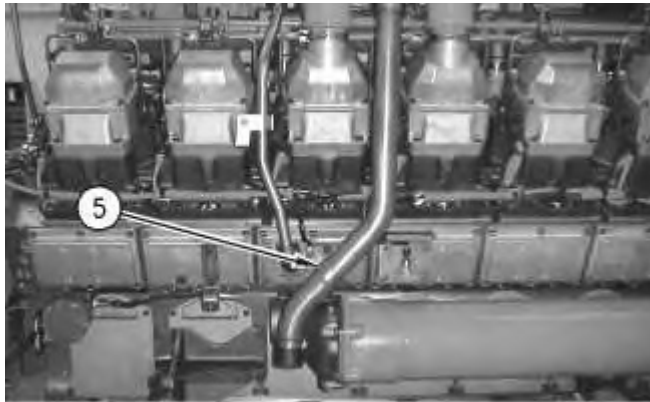

Illustration 6

g00915174

6. Install clamp (5).

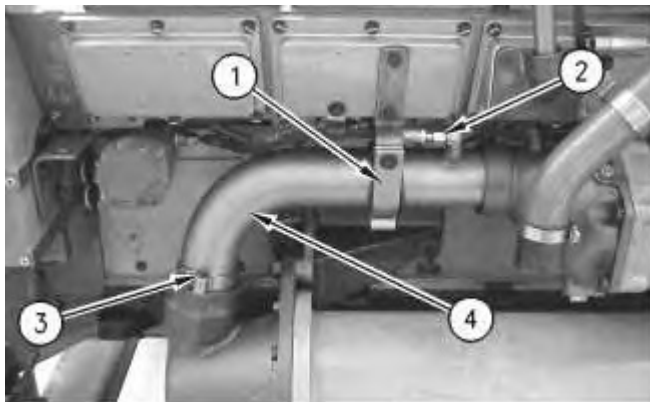

Illustration 7

g00915172

7. Install tube assembly (4). Install bolts (3) into the flange. Connect hose assembly (2). Install clamp (1).

<https://www.ebooklibonline.com>

Hello dear friend!

Thank you very much for reading.

Enter the link into your browser.

The full manual is available for immediate download.

<https://www.ebooklibonline.com>

Product: TRUCK

Model: 777B TRUCK 4YC

Configuration: 776B TRACTOR & 777B TRUCK 4YC00001-UP (MACHINE) POWERED BY 3508 ENGINE

Disassembly and Assembly

3500 and 3500B High Displacement Engines for Caterpillar Built Machines

Media Number -SEN1126-33

Publication Date -01/07/2015

Date Updated -14/09/2018

i02433907

Engine Oil Cooler Bypass Valve - Remove and Install

SMCS - 1314-010

Removal Procedure

Start By:

- a. Remove the engine oil cooler. Refer to Disassembly and Assembly, "Engine Oil Cooler - Remove".

NOTICE

Care must be taken to ensure that fluids are contained during performance of inspection, maintenance, testing, adjusting, and repair of the product. Be prepared to collect the fluid with suitable containers before opening any compartment or disassembling any component containing fluids.

Refer to Special Publication, NENG2500, "Dealer Service Tool Catalog" for tools and supplies suitable to collect and contain fluids on Cat[®] products.

Dispose of all fluids according to local regulations and mandates.

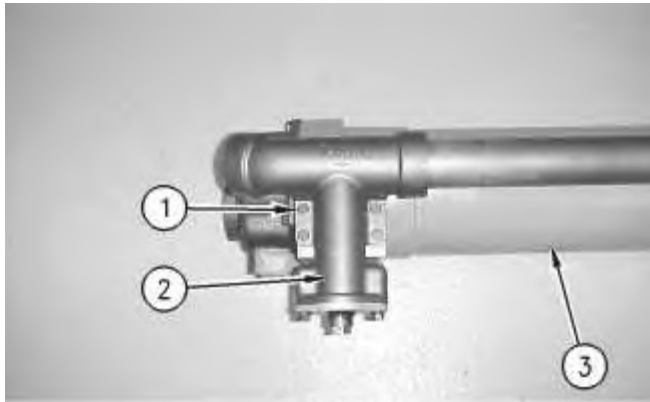

Illustration 1

g00892677

1. Remove bolts (1) and housing (2) from engine oil cooler (3).



Illustration 2

g00892681



Personal injury can result from being struck by parts propelled by a released spring force.

Make sure to wear all necessary protective equipment.

Follow the recommended procedure and use all recommended tooling to release the spring force.

2. Remove bolts (7) and cover (6). Remove spring (5) and plunger (4).

Note: The engine oil cooler bypass valve can be removed while the engine oil cooler is still on the engine.

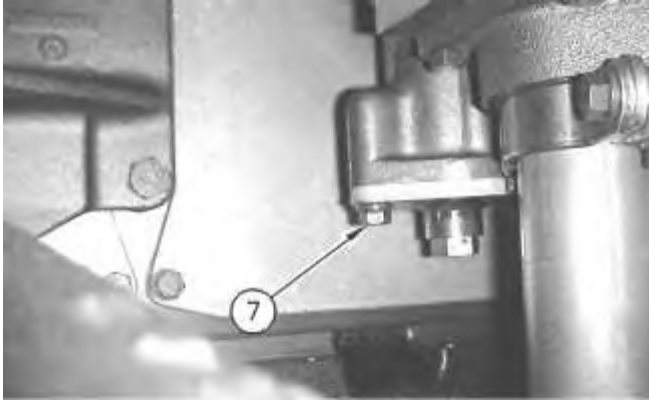

Illustration 3

g00892694

WARNING

Personal injury can result from being struck by parts propelled by a released spring force.

Make sure to wear all necessary protective equipment.

Follow the recommended procedure and use all recommended tooling to release the spring force.

3. Remove bolts (7) and disassemble the bypass valve.

Installation Procedure



Illustration 4

g00892681

WARNING

Improper assembly of parts that are spring loaded can cause bodily injury.

To prevent possible injury, follow the established assembly procedure and wear protective equipment.

1. Install plunger (4) and spring (5). Position cover (6) and install bolts (7).

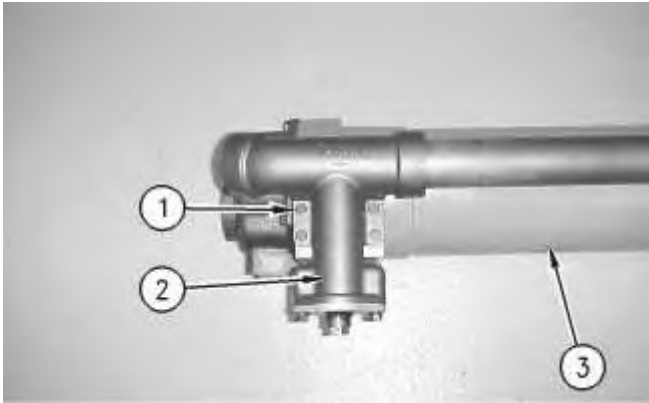

Illustration 5

g00892677

2. Position housing (2) on engine oil cooler (3) and install bolts (1).

Note: The engine oil cooler bypass valve can be installed while the engine oil cooler is still on the engine.

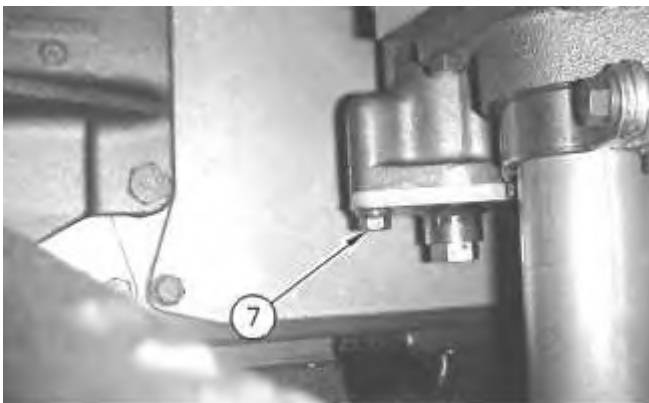

Illustration 6

g00892694

 **WARNING**

Improper assembly of parts that are spring loaded can cause bodily injury.

To prevent possible injury, follow the established assembly procedure and wear protective equipment.

3. Assemble the bypass valve and install bolts (7).

End By:

a. Install the engine oil cooler. Refer to Disassembly and Assembly, "Engine Oil Cooler - Install".

Product: TRUCK

Model: 777B TRUCK 4YC

Configuration: 776B TRACTOR & 777B TRUCK 4YC00001-UP (MACHINE) POWERED BY 3508 ENGINE

Disassembly and Assembly

3500 and 3500B High Displacement Engines for Caterpillar Built Machines

Media Number -SEN1126-33

Publication Date -01/07/2015

Date Updated -14/09/2018

i02431859

Transmission Oil Cooler - Remove and Install

SMCS - 1375-010

S/N - 2GR1-UP

S/N - 7TR1-UP

S/N - 7YG1-UP

S/N - 8BR1-UP

S/N - 8NZ1-UP

S/N - 8WM1-UP

S/N - JDM1-UP

Removal Procedure

NOTICE

Care must be taken to ensure that fluids are contained during performance of inspection, maintenance, testing, adjusting, and repair of the product. Be prepared to collect the fluid with suitable containers before opening any compartment or disassembling any component containing fluids.

Refer to Special Publication, NENG2500, "Dealer Service Tool Catalog" for tools and supplies suitable to collect and contain fluids on Cat[®] products.

Dispose of all fluids according to local regulations and mandates.

1. Drain the cooling system coolant into a suitable container for storage or disposal.

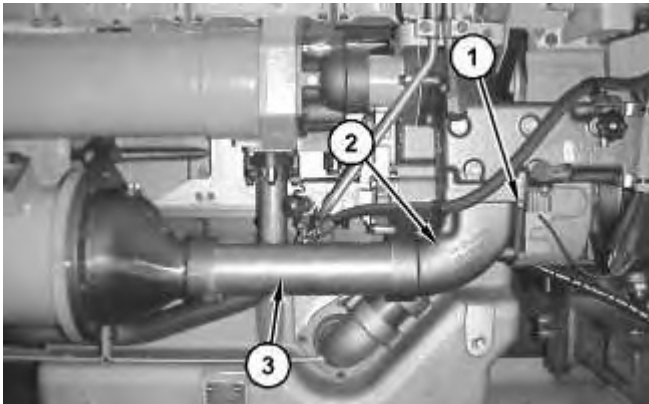

Illustration 1

g01052354

2. Remove bolts (1). Remove elbow (2) and tube assembly (3).
3. Attach a suitable lifting device onto the transmission oil cooler.

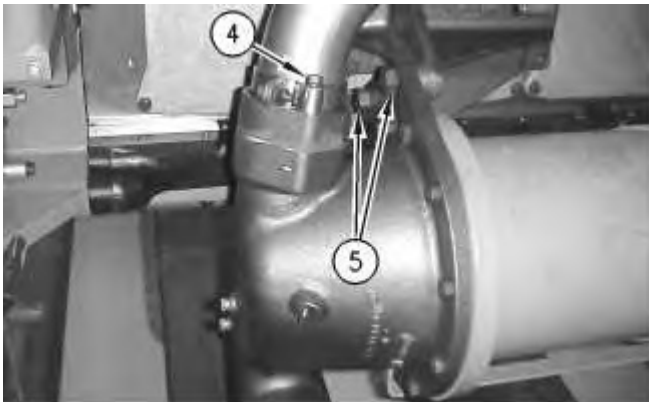

Illustration 2

g00917854

4. Remove bolts (4). Remove bolts (5).

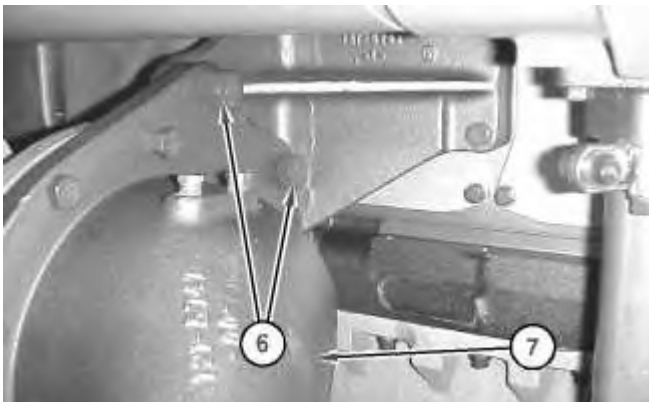

Illustration 3

g01052355

5. Remove bolts (6) and remove transmission oil cooler (7). The weight of transmission oil cooler (7) is approximately 181 kg (400 lb).

Installation Procedure

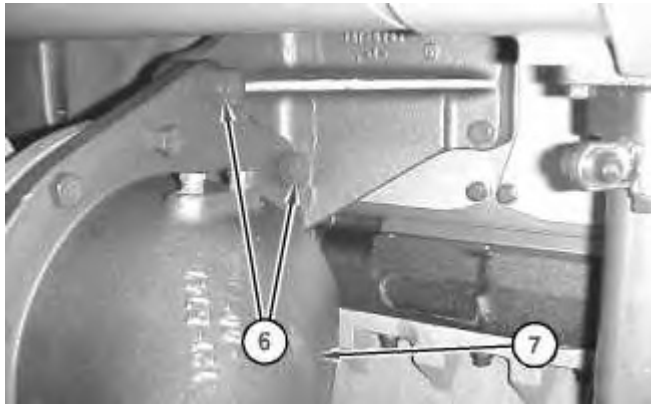

Illustration 4

g01052355

1. Attach a suitable lifting device onto transmission oil cooler (7). Install transmission oil cooler (7). The weight of transmission oil cooler (7) is approximately 181 kg (400 lb).
2. Install bolts (6).

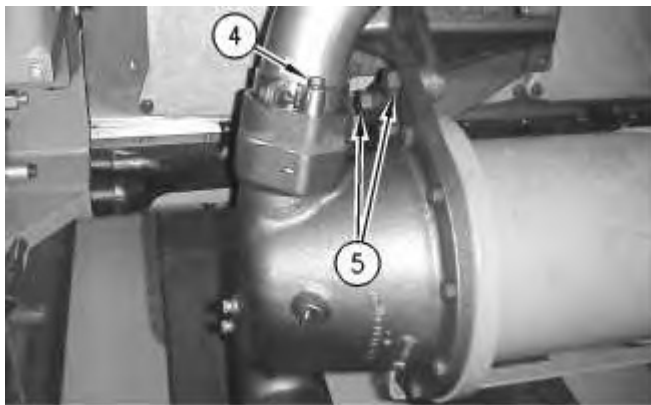

Illustration 5

g00917854

3. Install bolts (5). Install bolts (4).
-

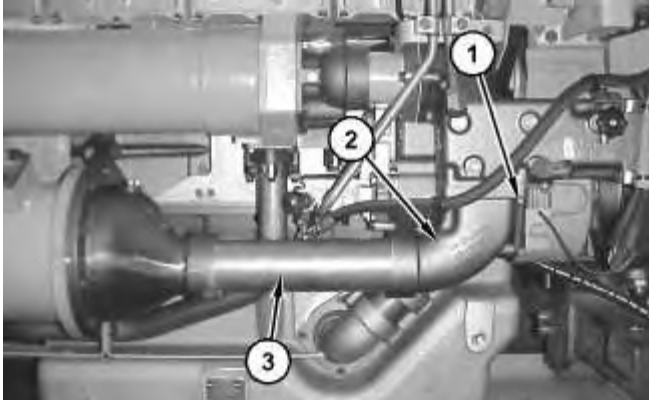

Illustration 6

g01052354

4. Install tube assembly (3) and elbow (2). Install bolts (1).
 5. Fill the cooling system.
-

Product: TRUCK

Model: 777B TRUCK 4YC

Configuration: 776B TRACTOR & 777B TRUCK 4YC00001-UP (MACHINE) POWERED BY 3508 ENGINE

Disassembly and Assembly

3500 and 3500B High Displacement Engines for Caterpillar Built Machines

Media Number -SEN1126-33

Publication Date -01/07/2015

Date Updated -14/09/2018

i06151950

Engine Oil Pump - Remove

SMCS - 1304-011

Removal Procedure

Table 1

Required Tools			
Tool	Part Number	Part Description	Qty
A	138-7573	Link Bracket	1

Start By:

- A. Remove the fuel transfer pump. Refer to Disassembly and Assembly, "Fuel Transfer Pump - Remove".

NOTICE

Care must be taken to ensure that fluids are contained during performance of inspection, maintenance, testing, adjusting, and repair of the product. Be prepared to collect the fluid with suitable containers before opening any compartment or disassembling any component containing fluids.

Refer to Special Publication, NENG2500, "Dealer Service Tool Catalog" for tools and supplies suitable to collect and contain fluids on Cat products.

Dispose of all fluids according to local regulations and mandates.

1. Drain the coolant from the cooling system into a suitable container for storage or disposal. Refer to the Operation and Maintenance Manual.

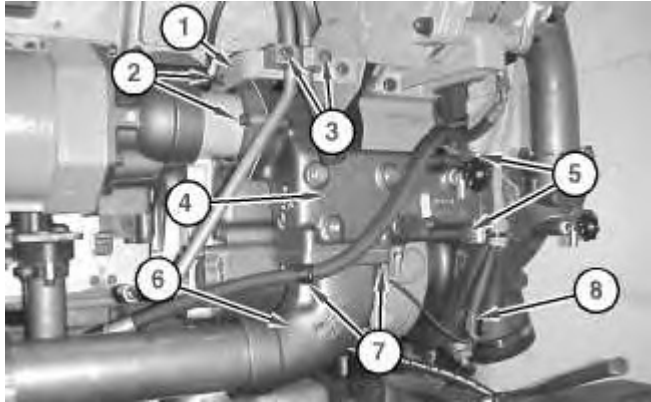

Illustration 1

g01052034

2. Disconnect harness assembly (8) .
3. Remove bolts (7) from elbow (6) .
4. Remove bolts (3) from the clamps.
5. Remove bolts (2) and remove bracket (1) .
6. Remove bolts (5) that hold housing (4) to the water pump. Remove housing (4) .

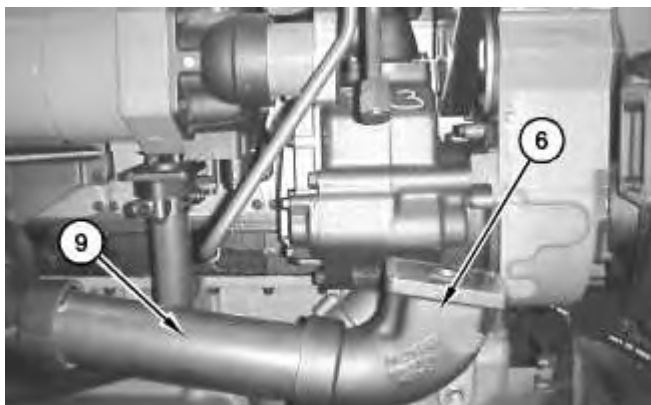

Illustration 2

g01052037

7. Remove elbow (6) and tube (9) .
-

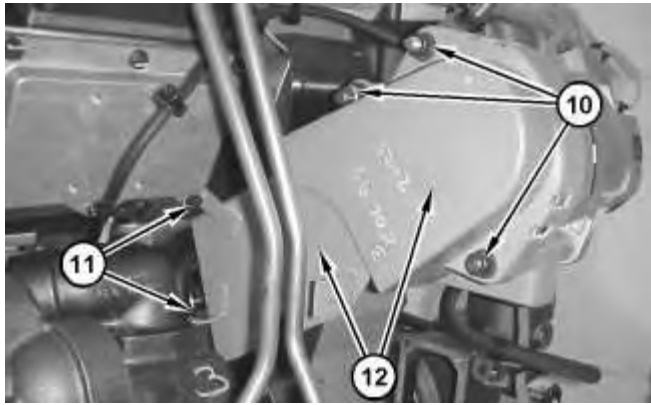

Illustration 3

g01052039

8. Remove bolts (11) and nuts (10) . Remove guards (12) .

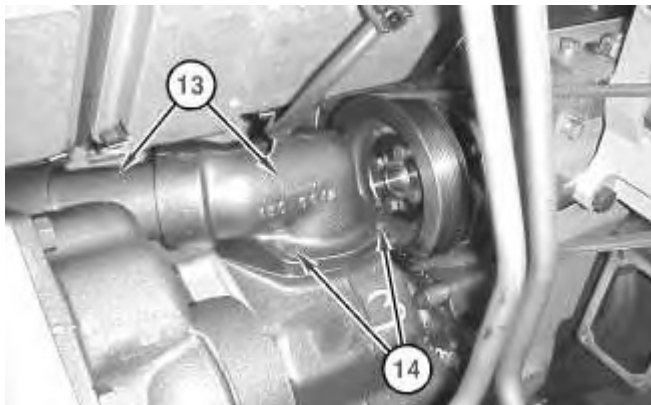

Illustration 4

g01052041

9. Remove bolts (14) and remove the elbow and tube (13) .

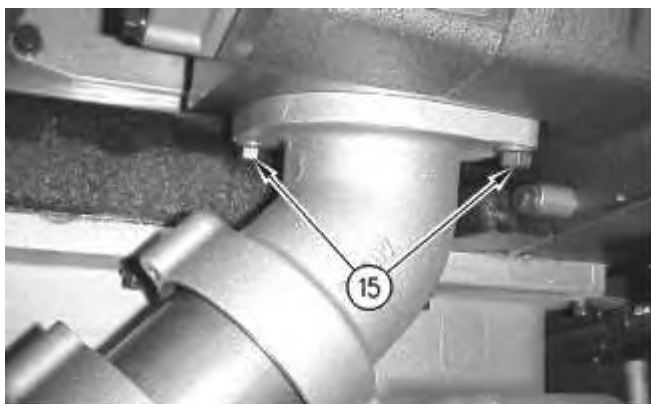

Illustration 5

g00916836

10. Remove bolts (15) .

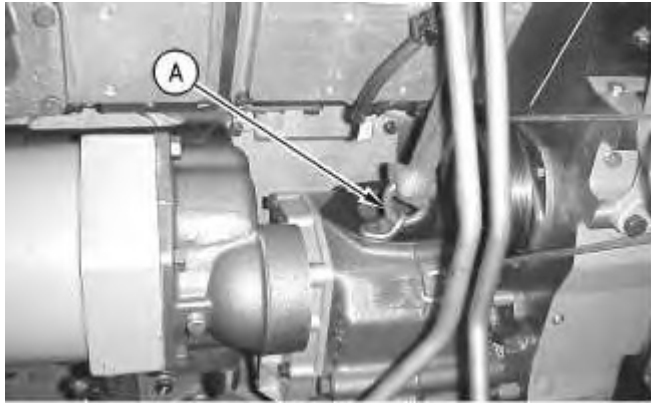

Illustration 6

g00916838

11. Install Tooling (A) and a suitable lifting device onto the oil pump.



Illustration 7

g03830107

12. Remove bolts (16) and slide the oil pump away from the drive. Remove oil pump (17) . The weight of oil pump (17) is approximately 45 kg (100 lb).
-

Product: TRUCK

Model: 777B TRUCK 4YC

Configuration: 776B TRACTOR & 777B TRUCK 4YC00001-UP (MACHINE) POWERED BY 3508 ENGINE

Disassembly and Assembly

3500 and 3500B High Displacement Engines for Caterpillar Built Machines

Media Number -SEN1126-33

Publication Date -01/07/2015

Date Updated -14/09/2018

i03392900

Engine Oil Pump - Disassemble

SMCS - 1304-015

Disassembly Procedure

Table 1

Required Tools			
Tool	Part Number	Part Description	Qty
A	1P-0510	Driver Group	1
B	156-7100	Slide Hammer Puller Gp	1

Start By:

- A. Remove the engine oil pump. Refer to Disassembly and Assembly, "Engine Oil Pump - Remove".

NOTICE

Keep all parts clean from contaminants.

Contaminants may cause rapid wear and shortened component life.



Illustration 1

g00921216

1. Remove adapter (1) .

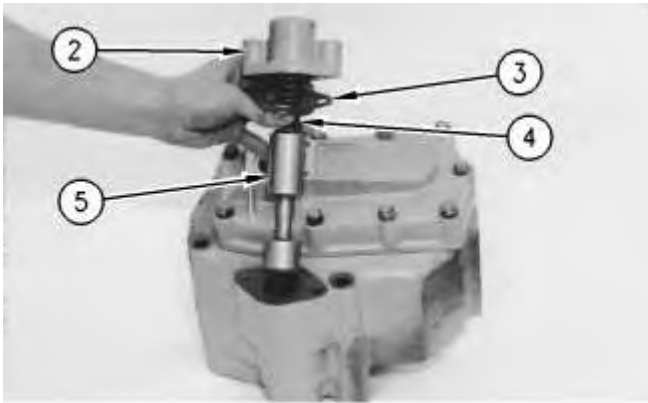

Illustration 2

g00921219

WARNING

Personal injury can result from parts and/or covers under spring pressure.

Spring force will be released when covers are removed.

Be prepared to hold spring loaded covers as the bolts are loosened.

2. Remove cover (2) , gasket (3) , spring (4) , and valve spool (5) .



Suggest:

For more complete manuals. Please go to the home page.

<https://www.ebooklibonline.com>

If the above button click is invalid. Please download this document first, and then click the above link to download the complete manual.

Thank you so much for reading



Illustration 3

g00921232

3. Remove cover assembly (6) and the gasket.



Illustration 4

g00921234

4. Remove cover assembly (7) .

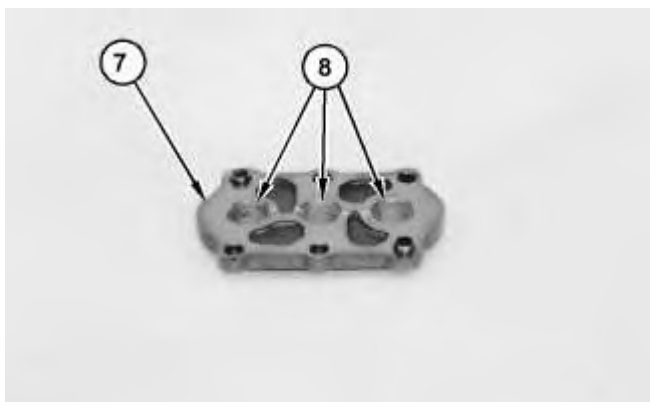

Illustration 5

g01050749

5. Use Tooling (A) to remove bearings (8) from cover assembly (7) .

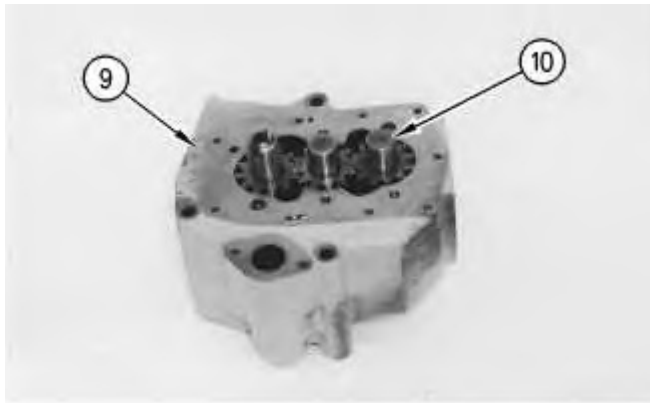

Illustration 6

g00921264

6. Remove shaft assemblies (10) from body (9) .

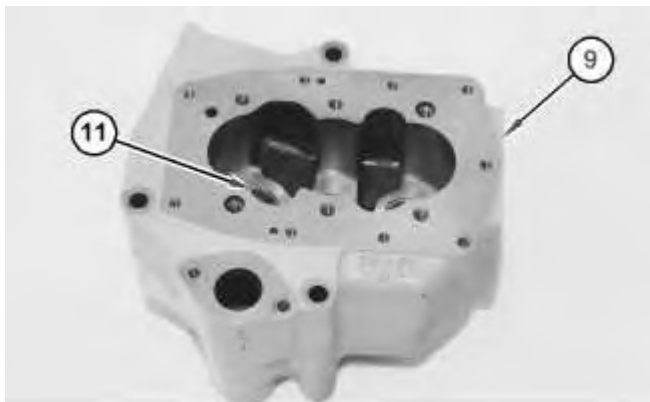

Illustration 7

g01052070

7. Remove bearings (11) from body (9) . Tooling (B) may be necessary in order to remove bearing (8) that is located in the blind hole.
-

<https://www.ebooklibonline.com>

Hello dear friend!

Thank you very much for reading.

Enter the link into your browser.

The full manual is available for immediate download.

<https://www.ebooklibonline.com>