

Product: TRUCK

Model: 777 TRUCK 84A

Configuration: 777 TRUCK 84A01284-UP (MACHINE) POWERED BY D348 ENGINE

Disassembly and Assembly

3500 and 3500B High Displacement Engines for Caterpillar Built Machines

Media Number -SEN1126-33

Publication Date -01/07/2015

Date Updated -14/09/2018

i02414981

Cylinder Head - Remove

SMCS - 1100-011

Removal Procedure

Table 1

Required Tools			
Tool	Part Number	Part Description	Qty
A	138-7573	Link Bracket	2

Start By:

- Remove the valve cover base. Refer to Disassembly and Assembly, "Valve Cover Base - Remove and Install".

NOTICE

Keep all parts clean from contaminants.

Contaminants may cause rapid wear and shortened component life.

NOTICE

Do not allow dirt to enter the fuel system. Thoroughly clean the area around a fuel system component that will be disconnected. Fit a suitable cover over disconnected fuel system component.

NOTICE

Care must be taken to ensure that fluids are contained during performance of inspection, maintenance, testing, adjusting, and repair of the product. Be prepared to collect the fluid with suitable containers before opening any compartment or disassembling any component containing fluids.

Refer to Special Publication, NENG2500, "Dealer Service Tool Catalog" for tools and supplies suitable to collect and contain fluids on Cat products.

Dispose of all fluids according to local regulations and mandates.

1. Drain the coolant from the cooling system. Refer to Operation and Maintenance Manual, "Cooling System Coolant - Change".

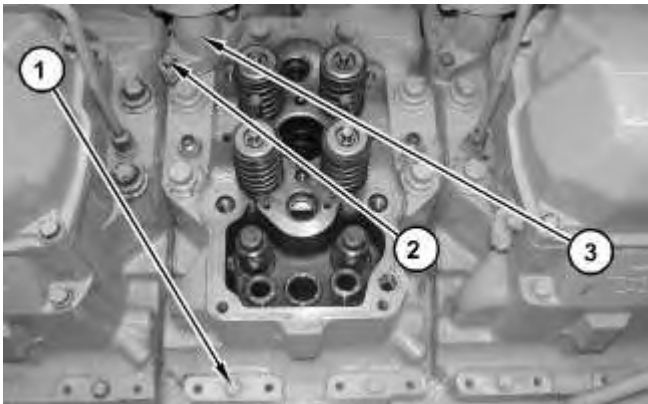

Illustration 1

g01053854

2. Remove bolts (1) and (2). Remove tube (3).

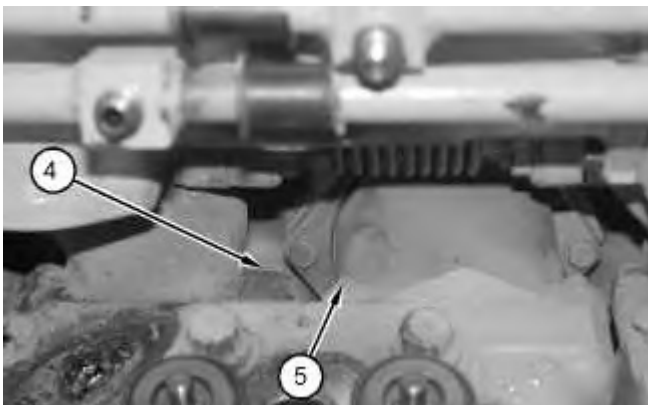

Illustration 2

g01053859

3. Remove four bolts (4) (not shown) from exhaust tube assembly and remove four bolts (5) (not shown) from inlet tube assembly.
-

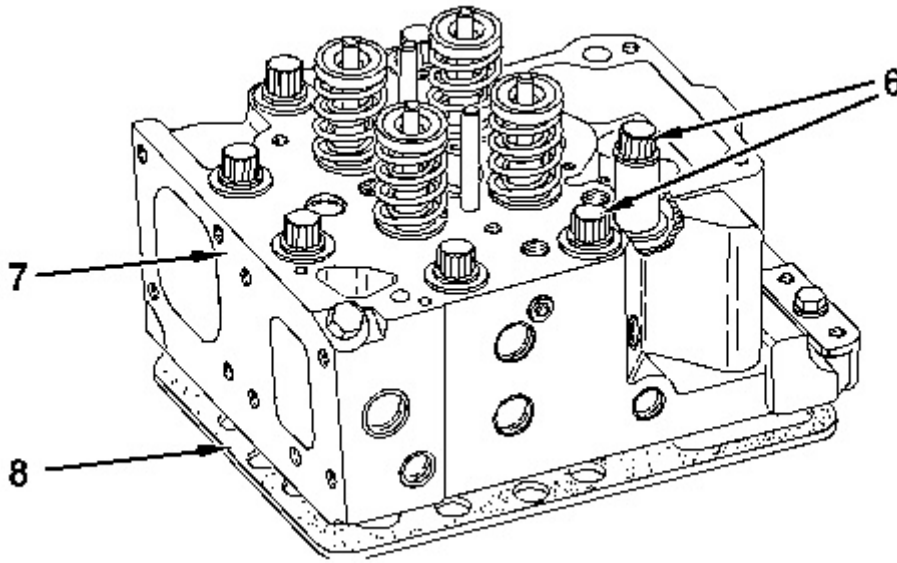

Illustration 3

g01053860

4. Remove bolts (6). Use a suitable lifting device and Tooling (A) in order to remove cylinder head assembly (7). The weight of cylinder head assembly (7) is approximately 47 kg (104 lb). Remove gasket (8).
-

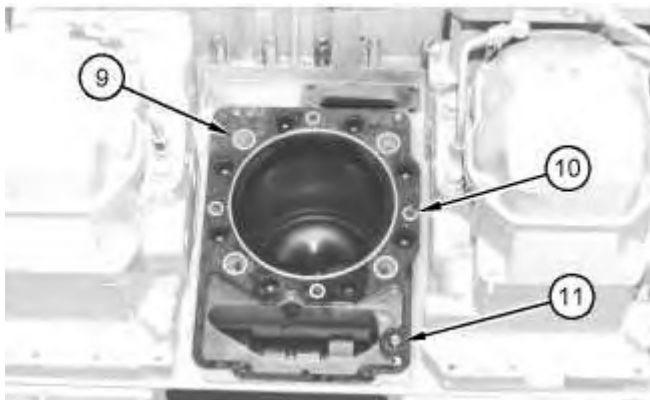

Illustration 4

g01053975

5. Remove seals (9) and (10), and O-ring seal (11) from the spacer plate.
-

<https://www.ebooklibonline.com>

Hello dear friend!

Thank you very much for reading.

Enter the link into your browser.

The full manual is available for immediate download.

<https://www.ebooklibonline.com>

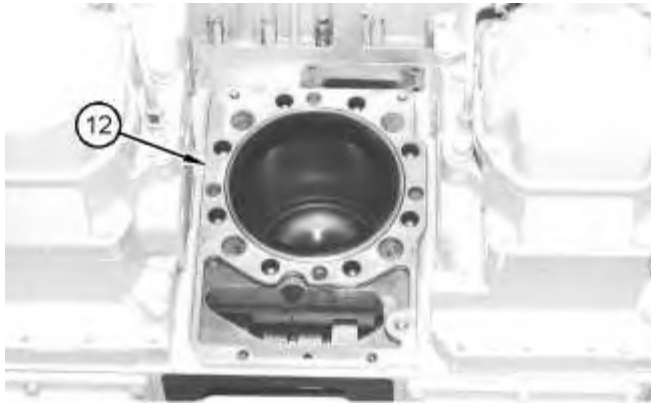

Illustration 5

g01053977

6. Remove spacer plate (12) from the dowels in the cylinder block.



Illustration 6

g01053978

7. Remove gasket (13) from the dowels.

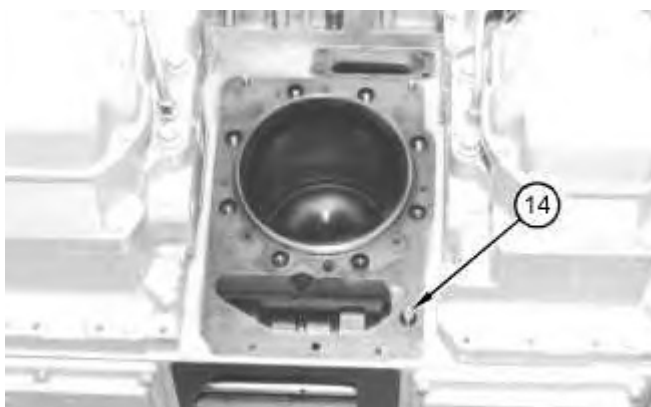

Illustration 7

g01053983

8. Remove the O-ring seal from dowel (14).
-

Product: TRUCK

Model: 777 TRUCK 84A

Configuration: 777 TRUCK 84A01284-UP (MACHINE) POWERED BY D348 ENGINE

Disassembly and Assembly

3500 and 3500B High Displacement Engines for Caterpillar Built Machines

Media Number -SEN1126-33

Publication Date -01/07/2015

Date Updated -14/09/2018

i02048542

Cylinder Head - Disassemble

SMCS - 1100-015

Disassembly Procedure

Start By:

- a. Remove the cylinder head. Refer to Disassembly and Assembly, "Cylinder Head - Remove".

Inlet and Exhaust Valves

Table 1

Required Tools			
Tool	Part Number	Part Description	Qty
A	5S-1330	Valve Spring Compressor	1
B	8S-2263	Spring Tester	1

NOTICE

Keep all parts clean from contaminants.

Contaminants may cause rapid wear and shortened component life.

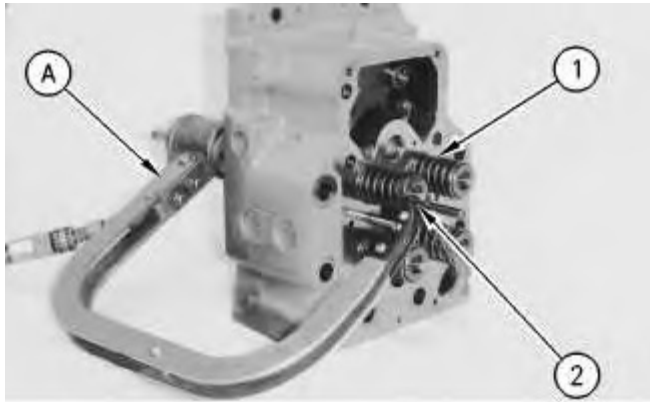

Illustration 1

g00905560

 **WARNING**

Personal injury can result from being struck by parts propelled by a released spring force.

Make sure to wear all necessary protective equipment.

Follow the recommended procedure and use all recommended tooling to release the spring force.

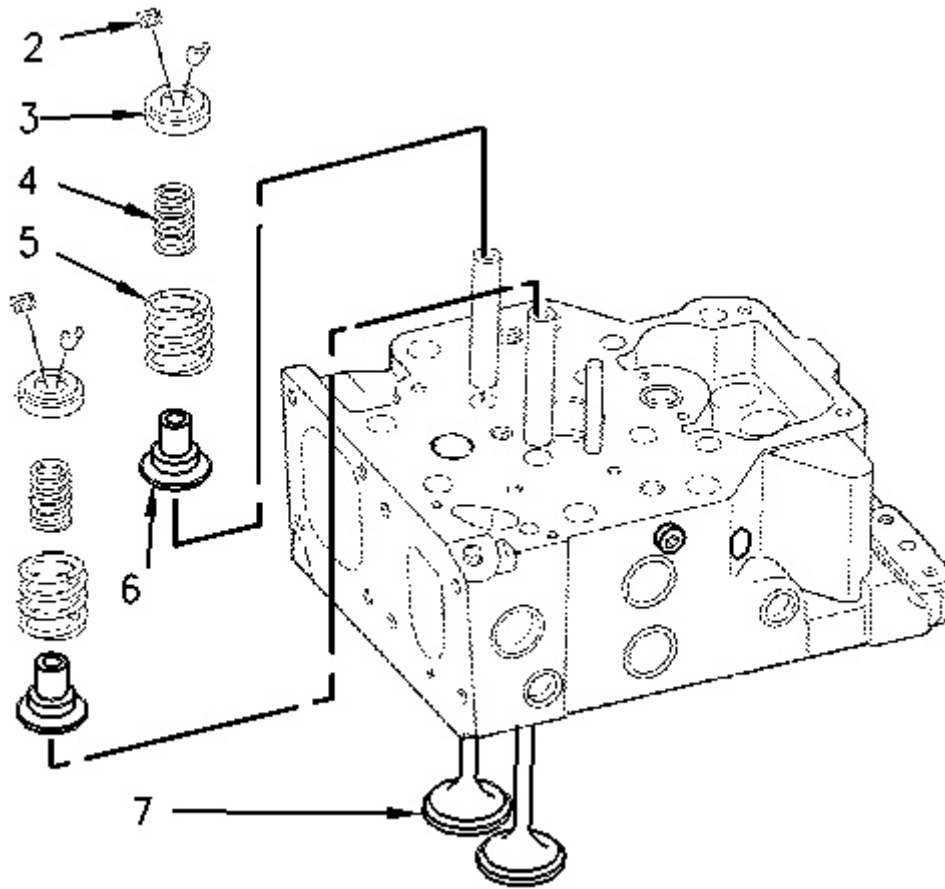

Illustration 2

g00618922

1. Use Tooling (A) to compress valve spring (1).
2. Remove retainer lock (2).
3. Release the tension on Tooling (A). Remove Tooling (A).
4. Remove valve rotator (3), outer spring (5), inner spring (4), and seal (6).

Note: If the valves will be reused, mark the valves for identification upon assembly.

5. Remove valve (7) from the cylinder head.
6. Use Tooling (B) to measure the force of the valve springs. Refer to Specifications for the correct spring force.
7. Repeat Steps 1 through 6 for the remaining valves.

Bridge Dowels

Table 2

Required Tools			
Tool	Part Number	Part Description	Qty
C	5P-0944	Dowel Puller Group	1

NOTICE

Keep all parts clean from contaminants.

Contaminants may cause rapid wear and shortened component life.

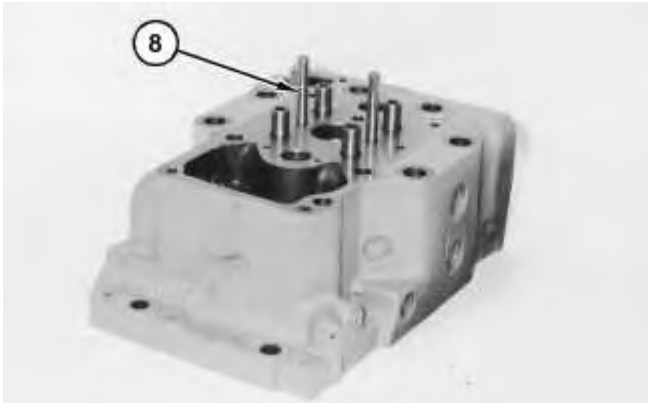

Illustration 3

g01051069

1. If the bridge dowels will be replaced, use Tooling (C) to remove bridge dowel (8) from the cylinder head.

Inlet and Exhaust Valve Seat Inserts

Table 3

Required Tools			
Tool	Part Number	Part Description	Qty
D	166-7441	Valve Seat Extractor Tool	1

NOTICE

Keep all parts clean from contaminants.

Contaminants may cause rapid wear and shortened component life.

1. Use Tooling (D) to remove the valve seat inserts from the cylinder head.
2. Thoroughly clean valve seat bores in the cylinder head.

Inlet and Exhaust Valve Guides

Table 4

Required Tools			
Tool	Part Number	Part Description	Qty
E	7M-3975	Valve Guide Driver	1
	5P-1729	Valve Guide Bushing	1

NOTICE

Keep all parts clean from contaminants.

Contaminants may cause rapid wear and shortened component life.

1. Use Tooling (E) and a hammer to remove the valve guides from the cylinder head.

Valve Lifters

NOTICE

Keep all parts clean from contaminants.

Contaminants may cause rapid wear and shortened component life.

Note: The valve lifters may also be removed with the cylinder head on the engine. Remove the camshaft and use the following steps in order to remove the valve lifters with the cylinder head on the engine.

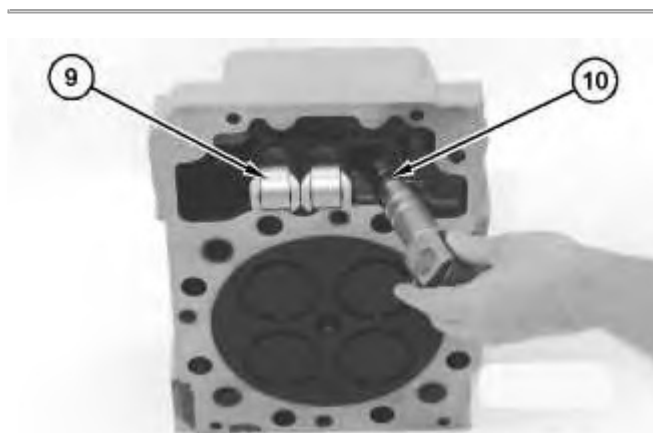

Illustration 4

g01051072

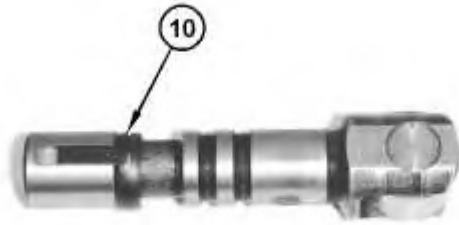

Illustration 5

g01051073

 **WARNING**

Personal injury can result from being struck by parts propelled by a released spring force.

Make sure to wear all necessary protective equipment.

Follow the recommended procedure and use all recommended tooling to release the spring force.

-
1. Pull valve lifter (9) out of the cylinder head.
 2. Remove guide spring (10) from the valve lifter.
-

Product: TRUCK

Model: 777 TRUCK 84A

Configuration: 777 TRUCK 84A01284-UP (MACHINE) POWERED BY D348 ENGINE

Disassembly and Assembly

3500 and 3500B High Displacement Engines for Caterpillar Built Machines

Media Number -SEN1126-33

Publication Date -01/07/2015

Date Updated -14/09/2018

i06795257

Cylinder Head - Assemble

SMCS - 1100-016

Assembly Procedure

Valve Lifters

NOTICE

Keep all parts clean from contaminants.

Contaminants may cause rapid wear and shortened component life.



Illustration 1

g01051073

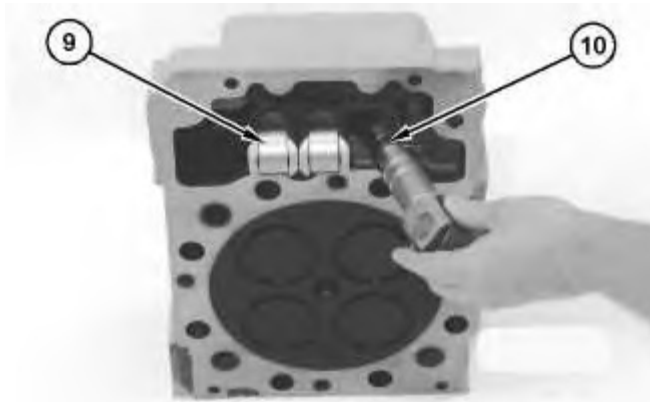

Illustration 2

g01051072

! WARNING

Improper assembly of parts that are spring loaded can cause bodily injury.

To prevent possible injury, follow the established assembly procedure and wear protective equipment.

Note: Install the lifter assembly into the cylinder head. Ensure that the word "LEFT" stamped on end of the bronze pin is always oriented to the LEFT as viewed from the side of the engine regardless of left side or right side bank. Immerse the lifter assembly in engine oil before assembled in the cylinder head lifter bore.

1. Install new guide spring (10) for valve lifter (9).
2. Place valve lifter (9) in a container of clean engine oil prior to installation.
3. Install valve lifter (9) into the cylinder head.

Note: Refer to Specifications, "Valve Mechanism".

Inlet and Exhaust Valve Guides

Table 1

Required Tools			
Tool	Part Number	Part Description	Qty
E	7M-3975	Valve Guide Driver	1
	5P-1729	Valve Guide Bushing	1

NOTICE

Keep all parts clean from contaminants.

Contaminants may cause rapid wear and shortened component life.

Note: Use new valve guides for assembly.

1. Coat the outside of the valve guides with clean engine oil prior to installation.
2. Use Tooling (E) and a suitable press to install the valve guides. The valve guide must extend 26.0 ± 0.50 mm (1.02 ± 0.020 inch) above the surface of the cylinder head.

Inlet and Exhaust Valve Seat Inserts

Table 2

Required Tools			
Tool	Part Number	Part Description	Qty
F	1P-0510	Driver Gp	1

NOTICE

Keep all parts clean from contaminants.

Contaminants may cause rapid wear and shortened component life.

Note: Use new inserts for assembly.

1. Lower the temperature of the valve seat inserts. Install the valve seat inserts with Tooling (F).

Bridge Dowels

Table 3

Required Tools			
Tool	Part Number	Part Description	Qty
G	6V-4009	Dowel Driver	1

NOTICE

Keep all parts clean from contaminants.

Contaminants may cause rapid wear and shortened component life.

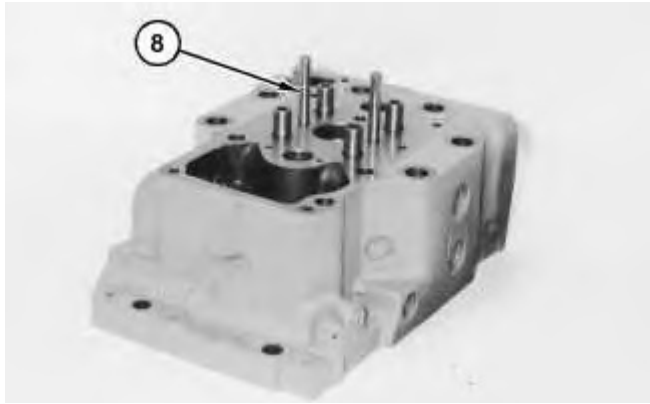

Illustration 3

g01051069

Note: Use new dowels for assembly. Refer to Service Magazine, SEPD1825, "New Cylinder Head Groups and Valve Mechanisms" for the correct procedure.

1. Use Tooling (G) with a hammer to install bridge dowels (8). The bridge dowels must extend 66.5 ± 0.50 mm (2.62 ± 0.020 inch) above the surface of the cylinder head.

Inlet and Exhaust Valves

Table 4

Required Tools			
Tool	Part Number	Part Description	Qty
A	5S-1330	Valve Spring Compressor	1

NOTICE

Keep all parts clean from contaminants.

Contaminants may cause rapid wear and shortened component life.

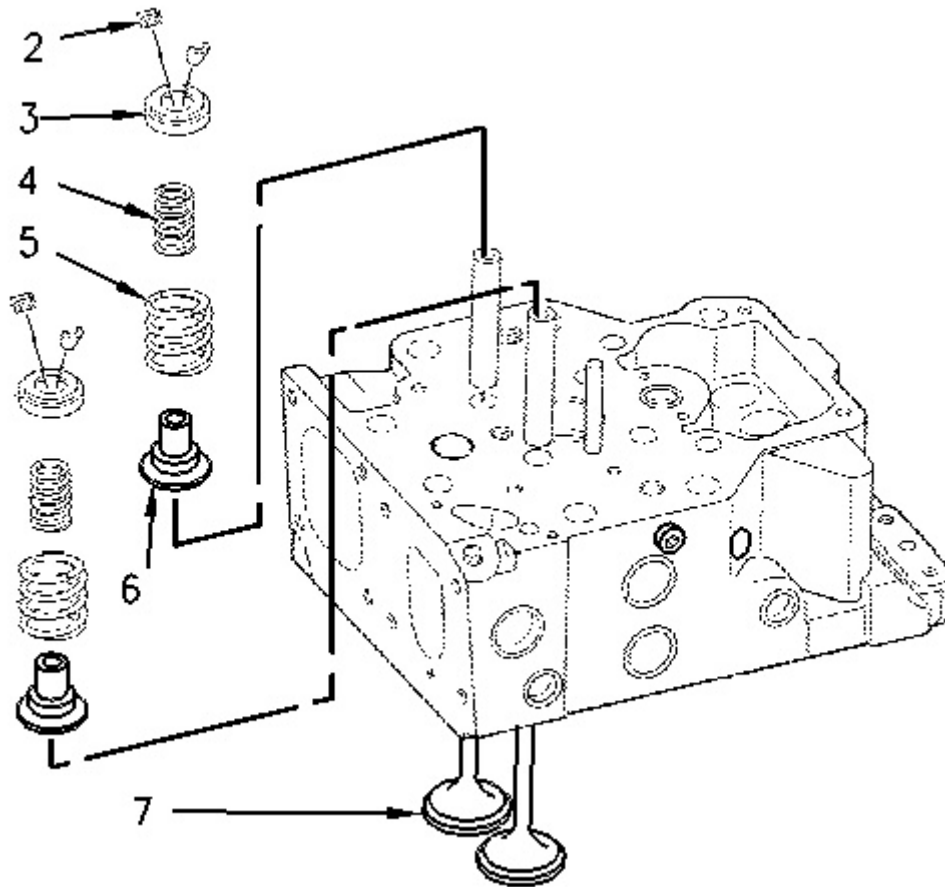

Illustration 4

g00618922

! WARNING

If the valve locks are not positioned correctly, the locks can be expelled when the spring pressure is released.

To help prevent personal injury, stay away from the front of the valve retainer and springs. Ensure that the valve locks are positioned correctly.

Note: Do not reuse valve rotocoils.

1. Coat valves (7) with clean engine oil. Install the valves into the cylinder head.
2. Install seal (6), inner spring (4), outer spring (5), and valve rotocoil (3) over the valve stem and the valve guide.
3. Compress the valve spring with Tooling (A) and install retainer lock (2).
4. Release the pressure on Tooling (A). Remove Tooling (A). Lightly tap the top of the valve with a hammer to ensure that the retainer locks are in the proper position.

5. Repeat Steps 1 through 4 for the remaining valves.

End By:

a. Install the cylinder head.

Product: TRUCK

Model: 777 TRUCK 84A

Configuration: 777 TRUCK 84A01284-UP (MACHINE) POWERED BY D348 ENGINE

Disassembly and Assembly

3500 and 3500B High Displacement Engines for Caterpillar Built Machines

Media Number -SEN1126-33

Publication Date -01/07/2015

Date Updated -14/09/2018

i07511232

Cylinder Head - Install

SMCS - 1100-012

Installation Procedure

Table 1

Required Tools			
Tool	Part Number	Part Description	Qty
A	439-3938	Link Bracket	2

NOTICE

Keep all parts clean from contaminants.

Contaminants may cause rapid wear and shortened component life.

1. Ensure that the spacer plate and the surface of the cylinder block are clean.

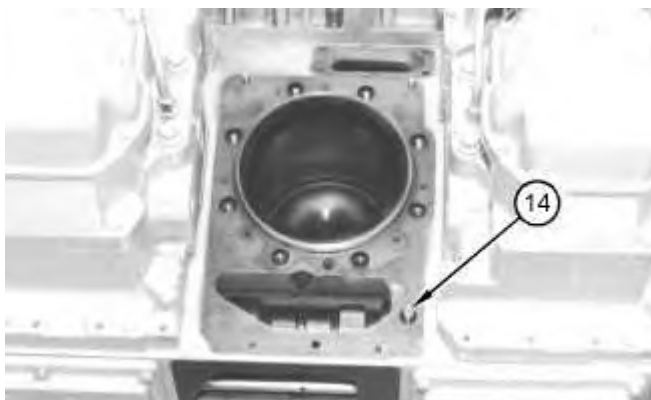

Illustration 1

g01053983

2. Install the O-ring seal on dowel (14).



Illustration 2

g01053978

NOTICE

Ensure that the surface of the spacer plate gasket and the surface of the cylinder block are clean. Do not use a gasket adhesive on these surfaces.

3. Install a new gasket (13) on the dowels in the cylinder block.

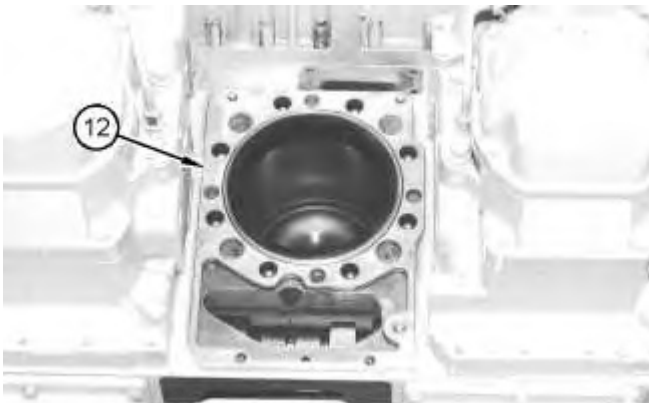

Illustration 3

g01053977

4. Install spacer plate (12) on the dowels.
 5. Check the cylinder liner projection. Refer to Testing and Adjusting, "Cylinder Liner Projection" for the correct procedure.
-

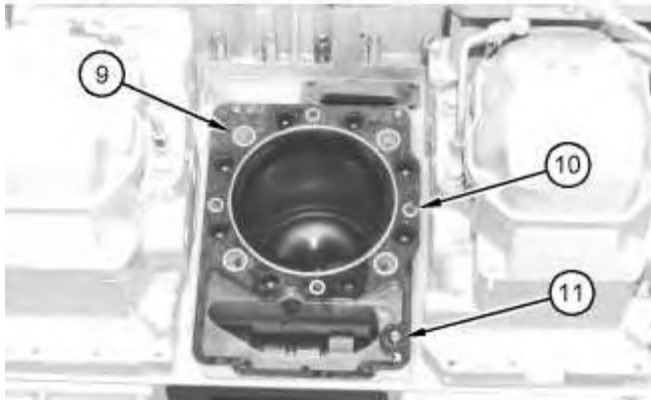

Illustration 4

g01053975

6. Install new seals (9) and (10) in the spacer plate.
7. Install a new O-ring seal (11) on the dowel.
8. Ensure that the bottom of the cylinder head assembly is thoroughly clean.

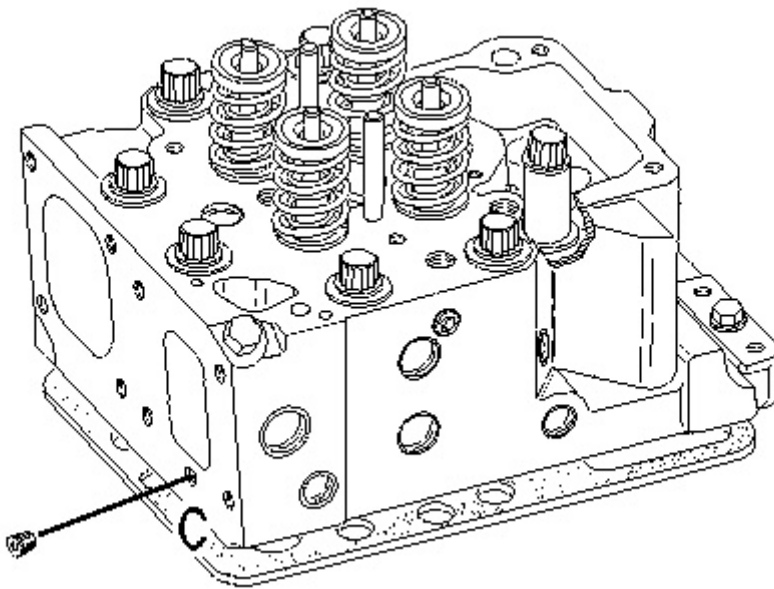

Illustration 5

g00618255

NOTICE

The plug for Location (C) MUST be installed in the cylinder head.

9. Install Tooling (A) into the threaded holes for the valve cover base in the cylinder head. Attach a suitable lifting device to Tooling (A).



Suggest:

For more complete manuals. Please go to the home page.

<https://www.ebooklibonline.com>

If the above button click is invalid. Please download this document first, and then click the above link to download the complete manual.

Thank you so much for reading

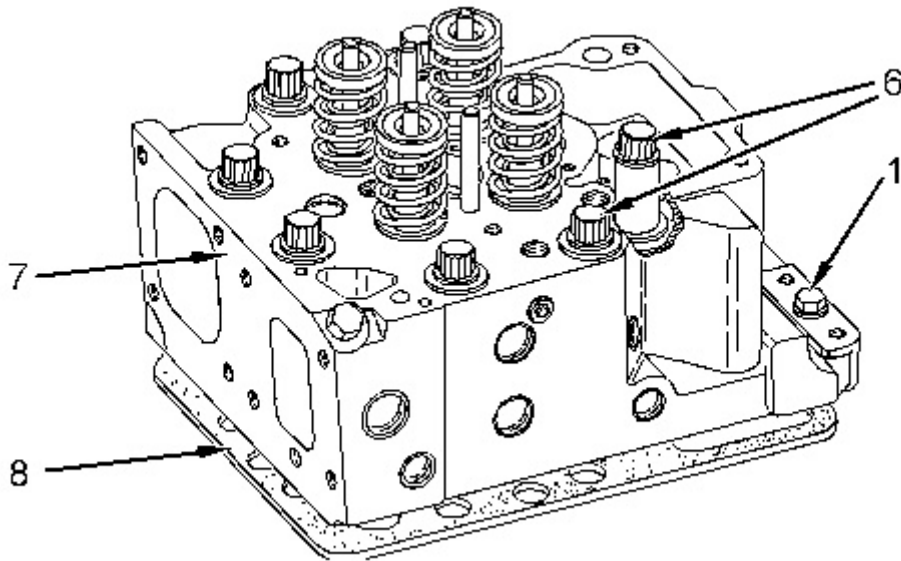

Illustration 6

g01053935

Note: The weight of cylinder head assembly (7) is approximately 47 kg (104 lb).

10. Install a new head gasket (8). Lift cylinder head assembly (7) into position on the cylinder block. Install bolts (6) and (1) according to the instructions in Step 11, Step 12, or Step 13.

Note: Only 216 mm (8.5 inch) bolts (6) can be used for the following torque procedures.

Note: Refer to Specifications, "Cylinder Head".

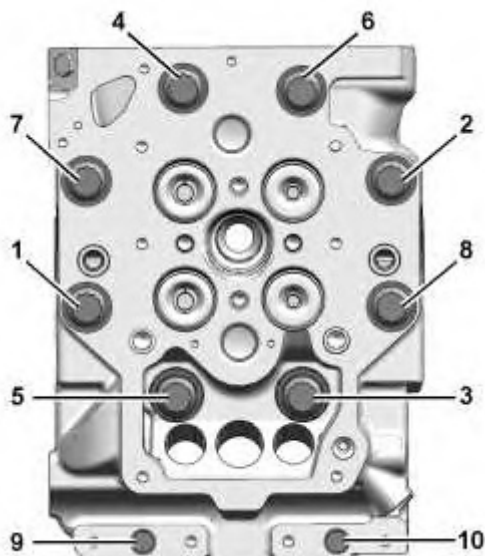

Illustration 7

g06344184

11. **Tightening sequence with 362-8264 Cylinder Head Gasket (MLS) and 519-7297 Spacer Plate (Iron).**

Note: Refer to Illustration 7 for the correct tightening sequence.

- a. Coat the threads of the bolts with clean engine oil.
- b. Tighten bolt (1) through bolt (8) to a torque of 30 ± 5 N·m (22 ± 4 lb ft).
- c. Tighten bolt (1) through bolt (8) to a torque of 145 ± 15 N·m (107 ± 11 lb ft).
- d. Tighten bolt (1) through bolt (8) to a torque of 145 ± 15 N·m (107 ± 11 lb ft).
- e. Turn bolt (1) through bolt (8) an angle of 180 ± 5 degrees.
- f. Tighten bolts (9) and (10) to a torque of 55 ± 10 N·m (40 ± 7 lb ft).

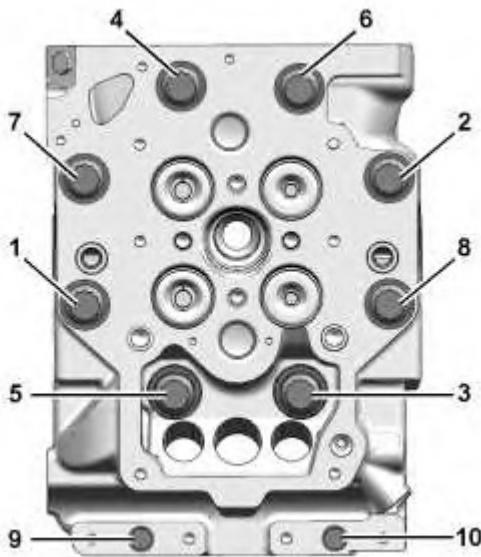

Illustration 8

g06344184

12. Tightening sequence with 362-8264 Cylinder Head Gasket (MLS) and 110-6994 Spacer Plate (Aluminum) or 362-9677 Spacer Plate (Aluminum).

Note: Refer to Illustration 8 for the correct tightening sequence.

- a. Coat the threads of the bolts with clean engine oil.
 - b. Tighten bolt (1) through bolt (8) to a torque of 30 ± 5 N·m (22 ± 4 lb ft).
 - c. Tighten bolt (1) through bolt (8) to a torque of 100 ± 15 N·m (75 ± 11 lb ft).
 - d. Tighten bolt (1) through bolt (8) to a torque of 450 ± 15 N·m (332 ± 11 lb ft).
 - e. Loosen bolt (1) through bolt (8) an angle of 90 degrees.
 - f. Tighten bolt (1) through bolt (8) to a torque of 490 ± 15 N·m (361 ± 11 lb ft).
 - g. Tighten bolt (9) and bolt (10) to a torque of 55 ± 10 N·m (40 ± 7 lb ft).
-

<https://www.ebooklibonline.com>

Hello dear friend!

Thank you very much for reading.

Enter the link into your browser.

The full manual is available for immediate download.

<https://www.ebooklibonline.com>