

Product: TRUCK

Model: 777 TRUCK 84A

Configuration: 777 TRUCK 84A00001-01283 (MACHINE) POWERED BY D348 ENGINE

Disassembly and Assembly

3500 and 3500B High Displacement Engines for Caterpillar Built Machines

Media Number -SEN1126-33

Publication Date -01/07/2015

Date Updated -14/09/2018

i02465569

Camshaft - Remove

SMCS - 1210-011

Removal Procedure

Table 1

Required Tools			
Tool	Part Number	Part Description	Qty
A	238-9586	Camshaft Drive Group	1
B	1P-0820	Hydraulic Puller	1
	8B-7548	Push-Puller Tool Group	1
	8B-7559	Adapter	2
	5H-1504	Hard Washer	3
	9U-6600	Hand Hydraulic Pump	1
C	125-0200	Camshaft Pilot As	2
D	125-0201	Camshaft Guide As	1
E	8T-3169	Crank Assembly	1

Start By:

- Remove the valve cover base. Refer to Disassembly and Assembly, "Valve Cover Base - Remove and Install".
- Remove the speed/timing sensor. Refer to the Service Manual, "Electronic Troubleshooting" module.

- c. Remove the electronic control module. Refer to Disassembly and Assembly, "Electronic Control Module (ECM) and Personality Module (PM) - Remove and Install".

NOTICE

Keep all parts clean from contaminants.

Contaminants may cause rapid wear and shortened component life.

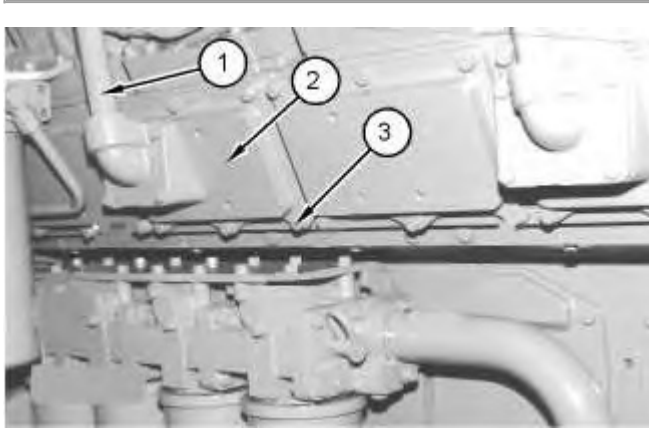

Illustration 1

g01007161

1. Remove tube assemblies (1).
2. Remove bolts (3) and covers (2) from both sides of the engine.

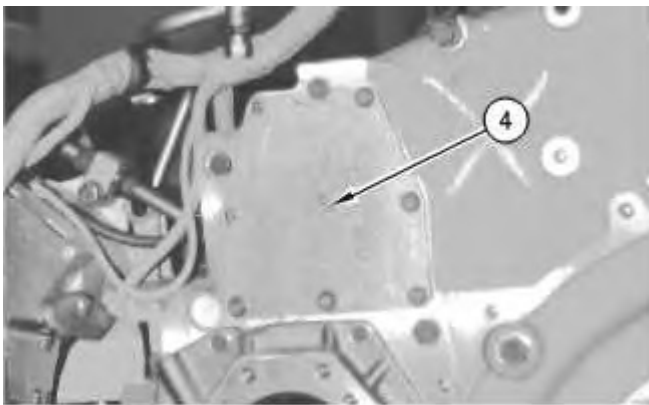

Illustration 2

g00914348

3. Remove covers (4) from both sides of the front housing.
-

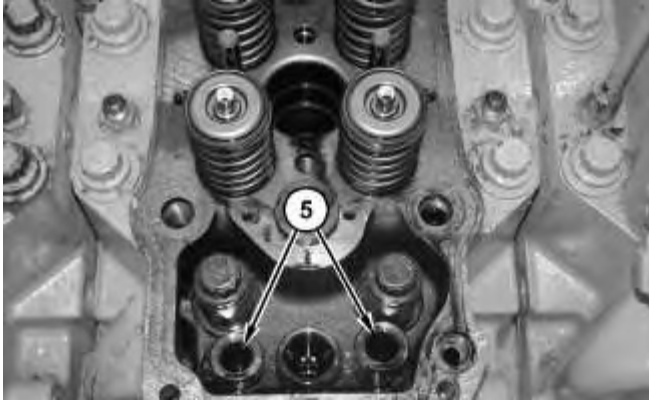

Illustration 3

g01053356

4. Pull valve lifters (5) away from the camshaft. Hold valve lifters (5) in position with O-ring seals.

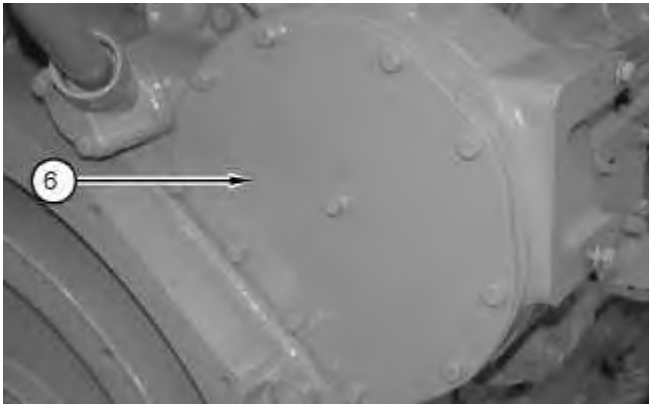

Illustration 4

g01053366

5. Remove covers (6) for the camshaft drive gears from the flywheel housing.

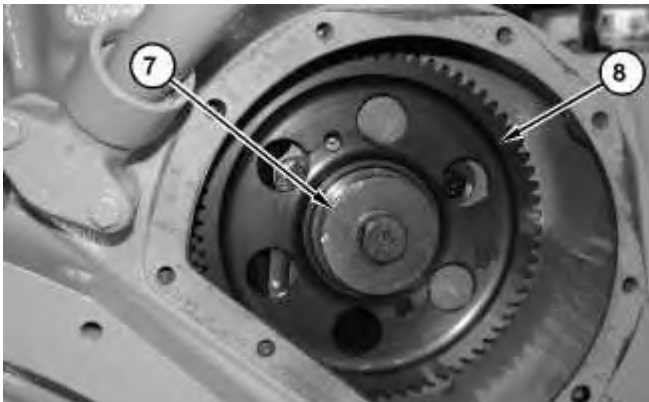

Illustration 5

g01053357

6. Remove the bolt and plate (7) that fastens camshaft drive gear (8) to the camshaft.

<https://www.ebooklibonline.com>

Hello dear friend!

Thank you very much for reading.

Enter the link into your browser.

The full manual is available for immediate download.

<https://www.ebooklibonline.com>

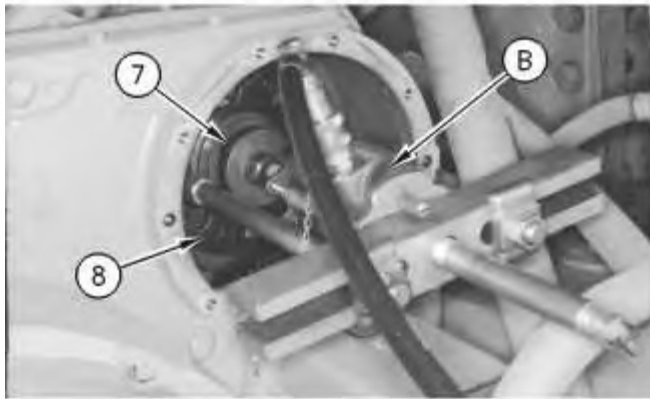

Illustration 6

g00914453

7. Place the three washers from Tooling (B) behind plate (7) and install the bolt.

NOTICE

Do not apply more than 51675 kPa (7500 psi) pressure to the hydraulic puller. The adapters are rated at 6 1/2 tons each and the hydraulic puller is rated at 17 tons at 68900 kPa (10000 psi). If too much pressure is applied, the gear may be damaged.

8. Install Tooling (B) on camshaft drive gear (8). Apply 51675 kPa (7500 psi) to Tooling (B). Strike the screw on Tooling (B) with a hammer until camshaft drive gear (8) is free from the camshaft. Remove Tooling (B) and camshaft drive gear (8).

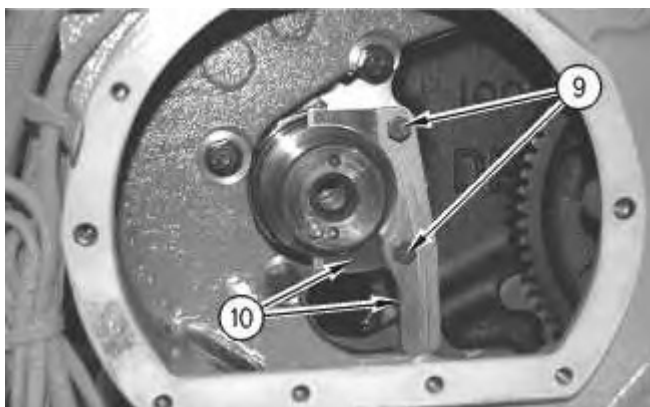

Illustration 7

g00613686

9. Remove bolts (9) and thrust washers (10) that fasten the camshaft to the engine block.
 10. Perform Steps 5 through 9 for the camshaft on the other side of the engine.
-

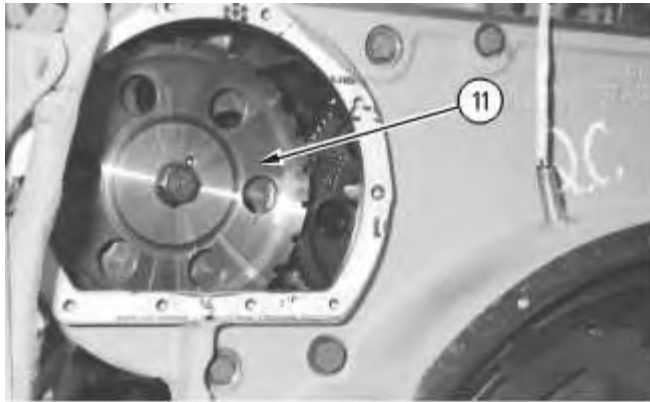

Illustration 8

g00914454

11. Remove timing ring (11) from the camshaft.

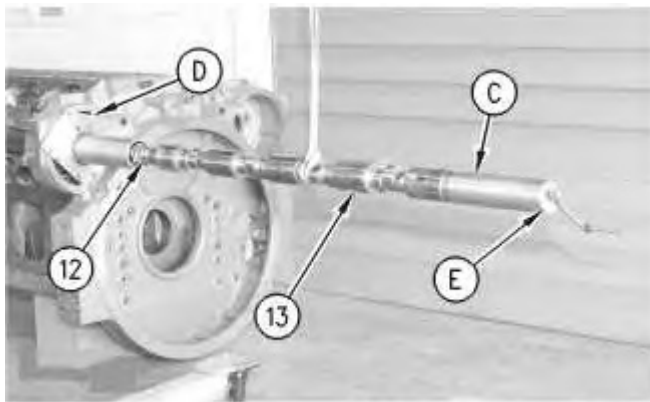

Illustration 9

g00914462

12. Install Tooling (C) on each end of the camshaft.

Note: Tooling (D) can be installed on the flywheel housing in order to remove the camshaft from the rear. Tooling (D) can also be installed on the front housing in order to remove the camshaft from the front of the engine.

13. Install Tooling (D) on the flywheel housing.
14. Install Tooling (E) on the end of Tooling (C).

Note: The following Step is for 3508B Engines.

Note: The weight of the camshaft for 3508 Engines is approximately 46 kg (101 lb). The camshaft is one piece.

15. Rotate the camshaft with Tooling (E). Pull the camshaft out of the engine until a suitable lifting device can be attached. Remove the camshaft from the engine.

Note: The following Steps are for 3512B and 3516B Engines.

Note: The weight of the camshaft for 3512B Engines is approximately 72 kg (158 lb). The weight of the camshaft for 3516B Engines is approximately 82 kg (181 lb).

16. Rotate the camshaft with Tooling (E). Pull the camshaft out of the engine until a suitable lifting device can be attached. Remove front camshaft (12) and rear camshaft (13) as a unit.

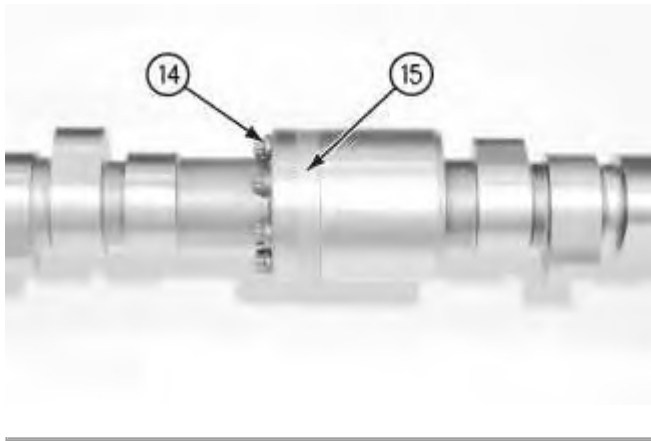

Illustration 10

g00579149

17. Remove bolts (14). Separate the camshafts and remove spacer (15).
 18. Remove the dowel from the front of the camshaft, if necessary.
 19. Repeat Steps 11 through 18 for the other camshaft.
-

Product: TRUCK

Model: 777 TRUCK 84A

Configuration: 777 TRUCK 84A00001-01283 (MACHINE) POWERED BY D348 ENGINE

Disassembly and Assembly

3500 and 3500B High Displacement Engines for Caterpillar Built Machines

Media Number -SEN1126-33

Publication Date -01/07/2015

Date Updated -14/09/2018

i03725162

Camshaft Bearings - Remove

SMCS - 1211-011

Removal Procedure

Table 1

Required Tools			
Tool	Part Number	Part Description	Qty
A	6V-4077	Camshaft Bearing Tool	1
	125-2739 ⁽¹⁾	Bearing Pilot	1
	125-2740 ⁽¹⁾	Back Up Plate	1
	125-2741 ⁽¹⁾	Bearing Sleeve	1
B	8S-2241	Camshaft Bearing Tool Group	1
C	5P-5247	Hydraulic Puller	1
D	8H-0684	Ratchet Wrench	1

⁽¹⁾ Alternate Tooling for camshaft bearings with a large diameter

Start By:

A. Remove the camshafts. Refer to Disassembly and Assembly, "Camshaft - Remove".

NOTICE

Keep all parts clean from contaminants.

Contaminants may cause rapid wear and shortened component life.



Illustration 1

g01208871

1. Use the following steps to install Tooling (A) .
 - a. Install the pilot group in camshaft bearing (1) (not shown).
 - b. Place the backup plate in position and ensure that camshaft bearing (1) (not shown) is between the two parts.
 - c. Install the bolt that holds Tooling (A) together.
 - d. Use the extensions to obtain the correct length for Tooling (A) .
 - e. Install the puller plate on the bolt and the flywheel housing or the front housing.

Note: Tooling (B) can be used to remove the camshaft bearings when the flywheel housing and the front housing have been removed.

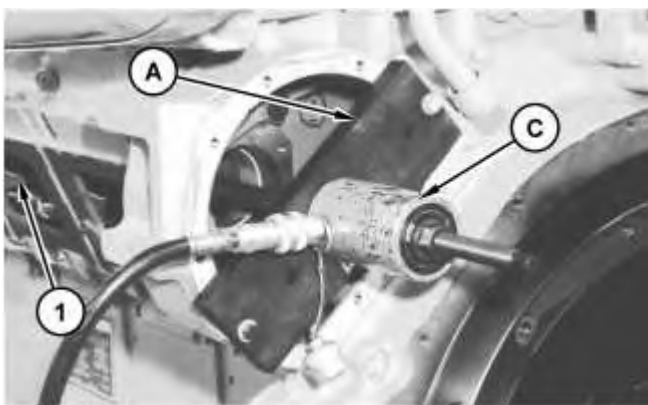

Illustration 2

g01208875

2. Install Tooling (C) on Tooling (A) . Pull camshaft bearing (1) from the cylinder block.

Note: Tooling (D) can be used in place of Tooling (C) , if necessary.

Product: TRUCK

Model: 777 TRUCK 84A

Configuration: 777 TRUCK 84A00001-01283 (MACHINE) POWERED BY D348 ENGINE

Disassembly and Assembly

3500 and 3500B High Displacement Engines for Caterpillar Built Machines

Media Number -SEN1126-33

Publication Date -01/07/2015

Date Updated -14/09/2018

i03725502

Camshaft Bearings - Install

SMCS - 1211-012

Installation Procedure

Table 1

Required Tool			
Tool	Part Number	Part Description	Qty
A	6V-4077	Camshaft Bearing Tool	1
	125-2739 ⁽¹⁾	Bearing Pilot	1
	125-2740 ⁽¹⁾	Back Up Plate	1
	125-2741 ⁽¹⁾	Bearing Sleeve	1
B	8S-2241	Camshaft Bearing Tool Group	1
C	5P-5247	Hydraulic Puller	1
D	8H-0684	Ratchet Wrench	1

⁽¹⁾ Alternate Tooling for camshaft bearings with a large diameter

NOTICE

Keep all parts clean from contaminants.

Contaminants may cause rapid wear and shortened component life.

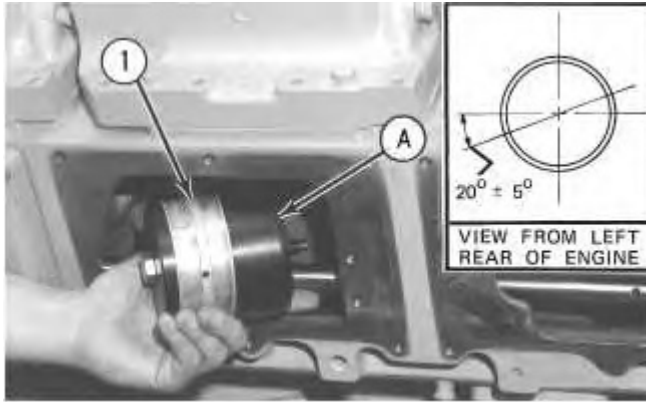

Illustration 1

g00578338

1. Install camshaft bearing (1) on Tooling (A) .

Note: Tooling (B) can be used to install the camshaft bearings when the flywheel housing and the front housing have been removed.

2. Position camshaft bearing (1) and Tooling (A) in the bore.

Note: The joint in camshaft bearing (1) must be on the horizontal centerline of the bore. The upper oil hole must be 20 ± 5 degrees above the horizontal centerline of the bore. The lower oil hole of camshaft bearing (1) should be 20 ± 5 degrees below the horizontal centerline of the bore. The joints of camshaft bearing (1) on the right side of the engine must face the inside of the cylinder block. The joints of camshaft bearing (1) on the left side of the engine must face the outside of the cylinder block.

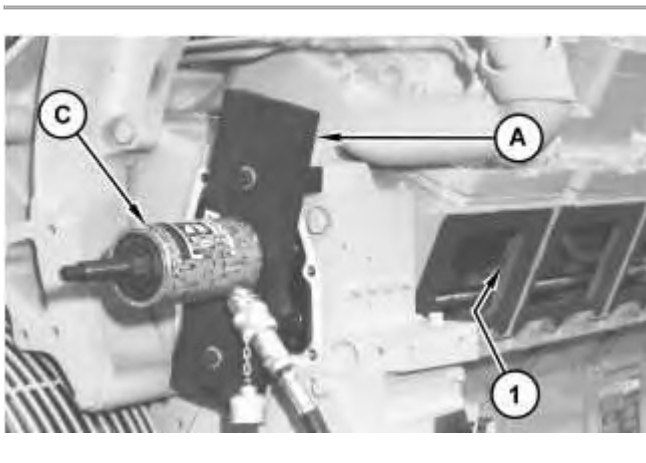

Illustration 2

g01208939

3. Install Tooling (C) on Tooling (A) and pull camshaft bearing (1) (not shown) into the bore.

Note: Tooling (D) can be used in place of Tooling (C) .

4. After camshaft bearing (1) (not shown) is installed, measure the bore. The bore must be 92.00 ± 0.06 mm (3.620 ± 0.002 inch).

End By: Install the camshafts. Refer to Disassembly and Assembly, "Camshaft - Install".

Product: TRUCK

Model: 777 TRUCK 84A

Configuration: 777 TRUCK 84A00001-01283 (MACHINE) POWERED BY D348 ENGINE

Disassembly and Assembly

3500 and 3500B High Displacement Engines for Caterpillar Built Machines

Media Number -SEN1126-33

Publication Date -01/07/2015

Date Updated -14/09/2018

i06883891

Camshaft - Install

SMCS - 1210-012

Installation Procedure

Table 1

Required Tools			
Tool	Part Number	Part Description	Qty
A	238-9586	Camshaft Drive Group	1
C	125-0200	Camshaft Pilot As	2
D	125-0201	Camshaft Guide As	1
E	8T-3169	Crank As	1

NOTICE

Keep all parts clean from contaminants.

Contaminants may cause rapid wear and shortened component life.

- The following steps are for the installation of a camshaft in the 3512B Engines and 3516B Engines.** The camshaft is in two pieces.

Note: Ensure that the camshafts are assembled and installed according to the marks on the ends of the camshafts.

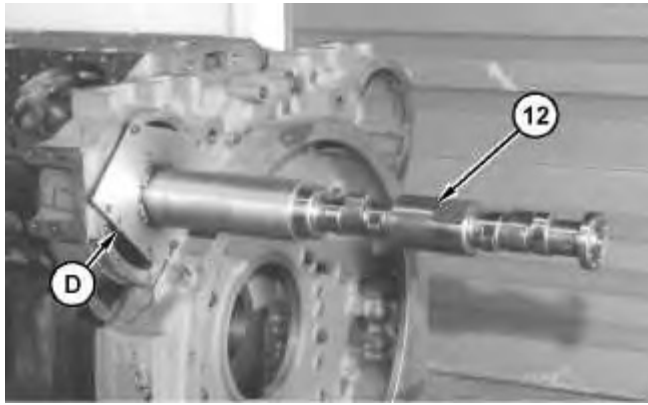

Illustration 1

g01053512

- a. Install Tooling (D) on the flywheel housing. Do not tighten the bolts on Tooling (D).
- b. Install Tooling (C) on the end of the front half of the camshaft.
- c. Ensure that the camshaft and the camshaft bearings are clean. Place clean engine oil on the lobes and the journals of the camshaft. Also place clean engine oil on the camshaft bearings.
- d. Attach a suitable lifting device to the camshaft. The weight of one-half of the camshaft for 3512B Engines is approximately 36 kg (80 lb). The weight of one-half of the camshaft for 3516B Engines is approximately 41 kg (90 lb).
- e. Position the front half of camshaft (12) in the engine until Tooling (C) is in the first camshaft bearing.
- f. Rotate camshaft (12) and tighten the bolts for Tooling (D).
- g. Rotate camshaft (12) and insert the camshaft until the camshaft is slightly protruding from Tooling (D).

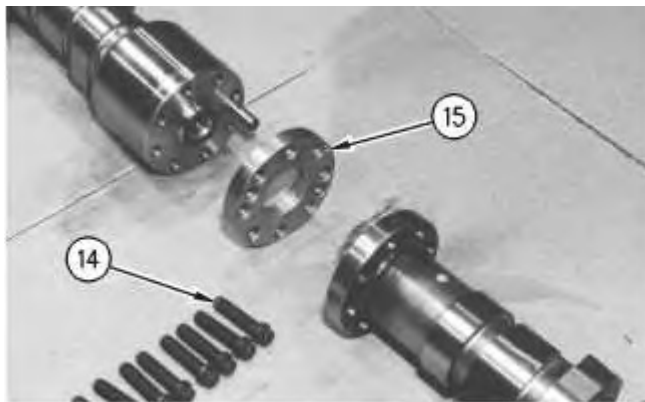

Illustration 2

g00914670

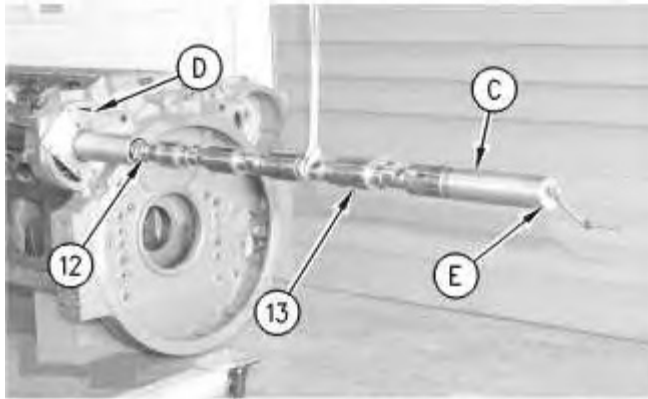

Illustration 3

g00914462

- h. If the dowel was removed from the front half of camshaft (12), install the dowel. Install the dowel to 22 ± 0.5 mm (0.9 ± 0.02 inch) from the surface of the camshaft.
 - i. Attach a suitable lifting device to rear half of camshaft (13). The weight of one-half of the camshaft for 3512B Engines is approximately 36 kg (80 lb). The weight of one-half of the camshaft for 3516B Engines is approximately 41 kg (90 lb). Install spacer (15) and the rear half of camshaft (13) onto the front half of camshaft (12). Install bolts (14) and tighten to a torque of 55 ± 7 N·m (41 ± 5 lb ft).
 - j. Install Tooling (C) and Tooling (E) on the rear half of camshaft (13).
 - k. Rotate the rear half of camshaft (13) and insert the camshaft into the engine.
 - l. Remove all Tooling. Repeat Steps 1.a through 1.k for the camshaft on the opposite side of the engine. Go to Step 3.
2. **The following steps are for the installation of the camshaft in 3508B Engines.** The camshaft is one piece.
- a. Install Tooling (D) on the flywheel housing. Do not tighten the bolts on Tooling (D).
 - b. Install Tooling (C) on the end of the camshaft.
 - c. Ensure that the camshaft and the camshaft bearings are clean. Place clean engine oil on the lobes and the journals of the camshaft. Also place clean engine oil on the camshaft bearings.
- Note:** Ensure that the camshafts are installed according to the marks on the ends of the camshafts.
- d. Attach a suitable lifting device to the camshaft. The weight of the camshaft is approximately 46 kg (101 lb). Insert the camshaft in the engine until Tooling (C) is in the first camshaft bearing.
 - e. Install Tooling (E). Rotate the camshaft and tighten the bolts on Tooling (D).
 - f. Rotate the camshaft and insert the camshaft into the engine.
 - g. Repeat Steps 2.a through 2.f for the camshaft on the opposite side of the engine. Go to Step 3.

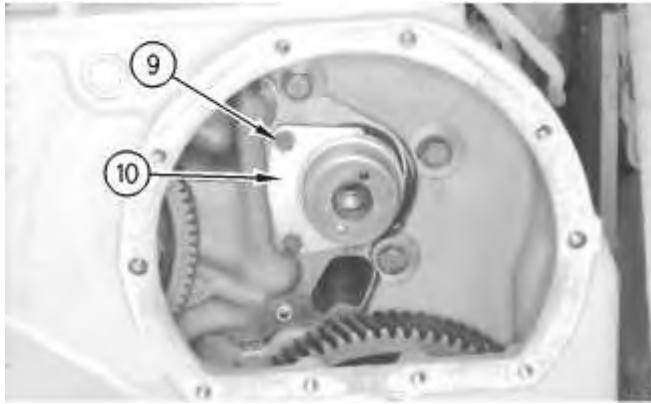

Illustration 4

g00914691

3. Install thrust washers (10). Install bolts and washers (9) that fasten the camshaft to the engine.

NOTICE

If the camshaft is out of time more than 18 degrees (approximately 1/2 of the timing pin is out of the groove), the valves can make contact with the pistons. This will cause damage to the engine. Refer to Testing and Adjusting, "Camshaft Timing" for more information.



Illustration 5

g00914693

4. Remove timing pin (16) from the storage position on the side of the engine.
 5. Turn the camshaft until timing pin (16) can be installed through the cylinder block and into groove (17) that is in the camshaft.
 6. Repeat Steps 4 and 5 for the camshaft on the opposite side of the engine.
-

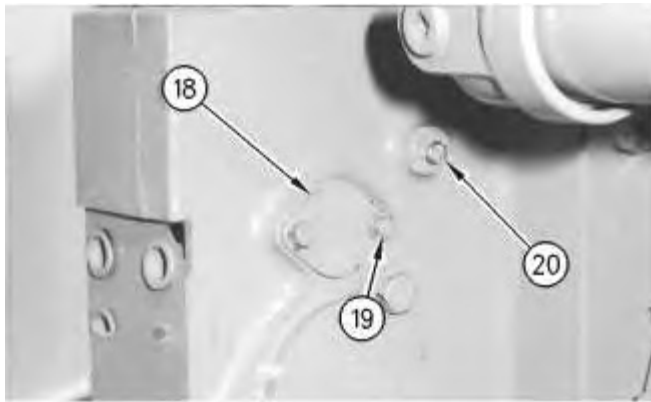

Illustration 6

g00914707

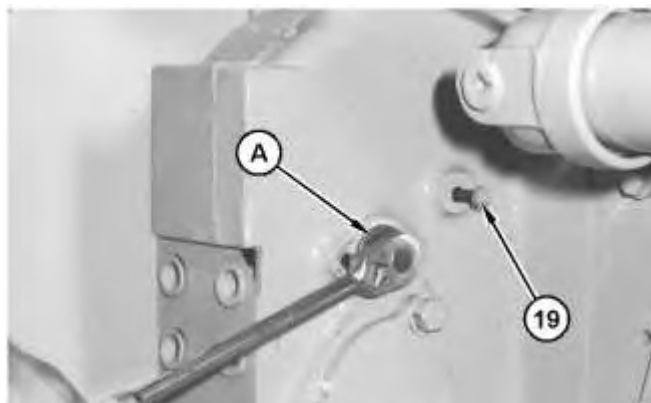

Illustration 7

g01053668

7. Remove bolts (19), cover (18), and plug (20).
8. Install one bolt (19) into the flywheel housing through the hole for plug (20). Use Tooling (A) and a ratchet to turn the flywheel until bolt (19) can be installed through the hole and into the flywheel. Doing so will position the No. 1 cylinder at the top center. Refer to Testing and Adjusting, "Finding the Top Center Position for the No. 1 Piston" for more information.



Illustration 8

g00914726

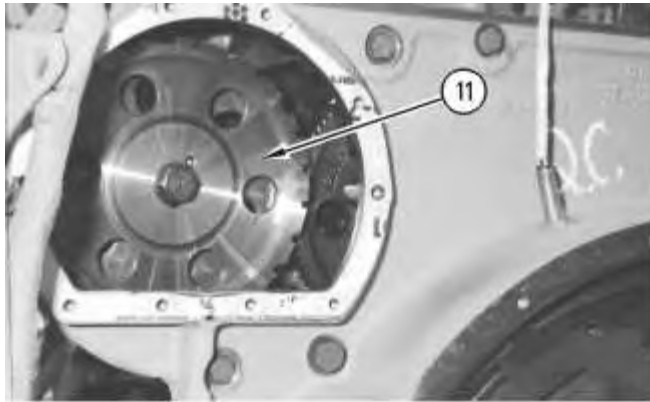

Illustration 9

g00914728

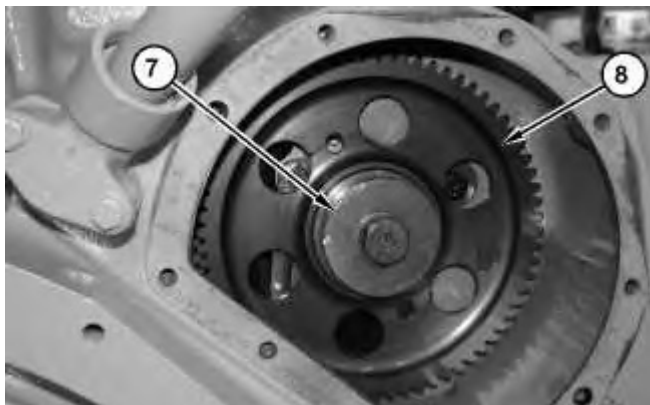

Illustration 10

g01053357

9. Use the following procedure to install camshaft drive gears (8).

- a. Clean the taper of the camshaft and the tapered bore of the camshaft gear with a lint free cloth saturated with solvent to remove oil. Clean the parts again with a lint free alcohol wipe to remove any residue. The alcohol wipe will dirty after cleaning the parts. Clean the parts again with a lint free alcohol wipe until no residue is left on the alcohol wipe.

Note: The taper of the camshaft and the tapered bore of the camshaft gear must be clean, dry, and free of residue before assembly.

- b. Ensure that the camshaft timing pins and the timing pin for the flywheel are installed.
- c. Place camshaft drive gears (8) in position. Remove the backlash by rotating the gears in the opposite direction of camshaft rotation.

Note: For "Standard Rotation" engines, turn the camshaft drive gears COUNTERCLOCKWISE. For "Reverse Rotation" engines, turn the camshaft drive gears CLOCKWISE.

- d. Install the bolt and plate (7).
- e. Install the bolt and timing ring (11). Ensure that the hole in the timing ring is properly seated on the locating pin.

- f. Tighten the bolt to a torque of 360 N·m (265 lb ft).
- g. Place a Mark on the bolt.
- h. Place a driver against the retaining plate of the camshaft gear. Strike the driver solidly with a hammer 3 to 4 times.
- i. Tighten the bolt again to a torque of 360 N·m (265 lb ft).
- j. Repeat Steps 9.h and 9.i until the Mark has turned at least 90 degrees.

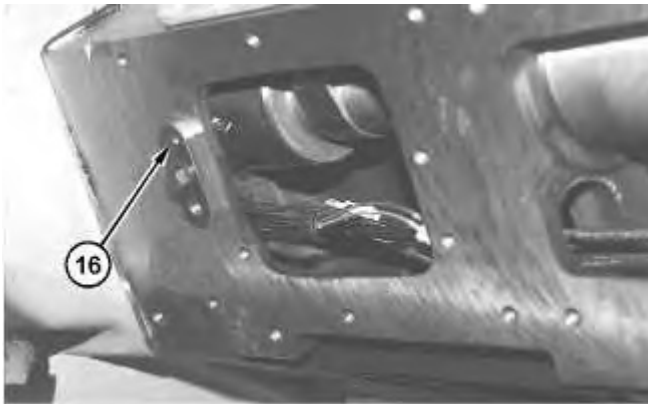

Illustration 11

g01053666

10. Remove the timing pins from the camshafts. Install timing pins (16) in the original locations.

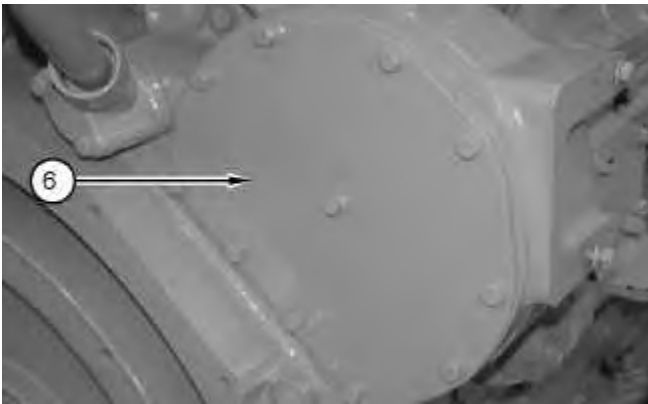

Illustration 12

g01053366

11. Install the gaskets and covers (6) over the camshaft drive gears on both sides of the engine.
-



Suggest:

For more complete manuals. Please go to the home page.

<https://www.ebooklibonline.com>

If the above button click is invalid. Please download this document first, and then click the above link to download the complete manual.

Thank you so much for reading

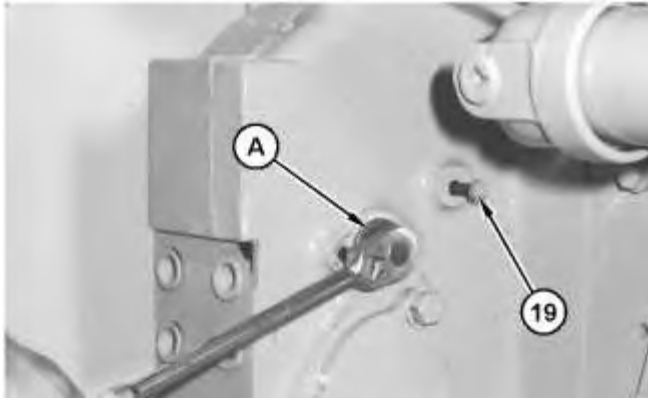

Illustration 13

g01053668

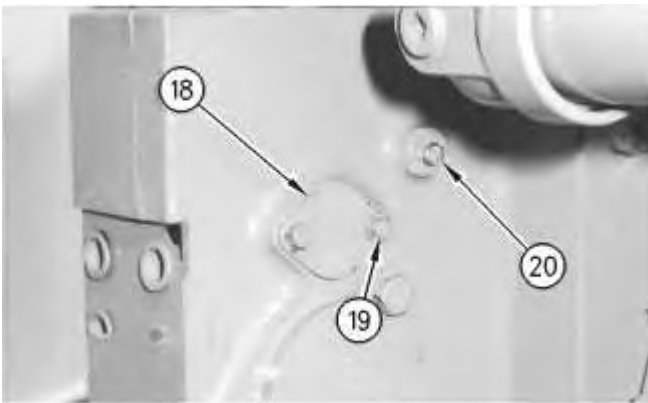

Illustration 14

g00914707

12. Remove bolt (19) from the flywheel. Install plug (20) in the timing hole. Remove Tooling (A) and install cover (18) with bolts (19) on the flywheel housing.

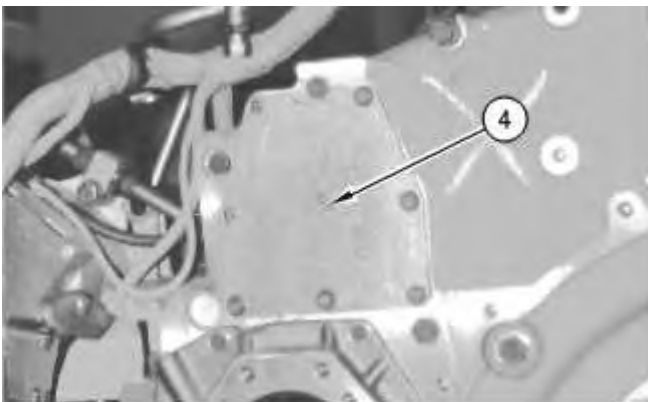

Illustration 15

g00914348

13. Install covers (4) on the front housing.

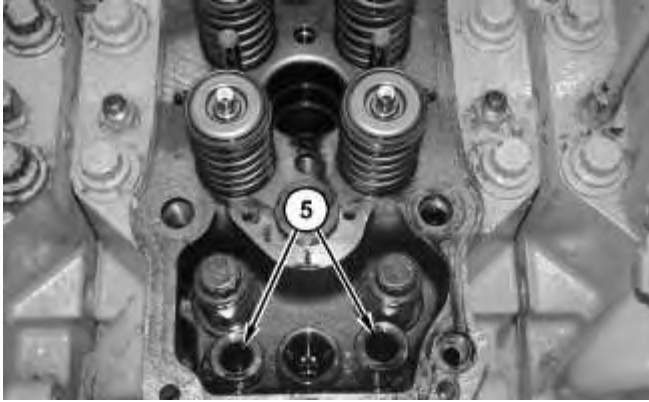

Illustration 16

g01053356

14. Remove the O-ring seals from valve lifters (5). Push the valve lifters (5) against the camshaft.

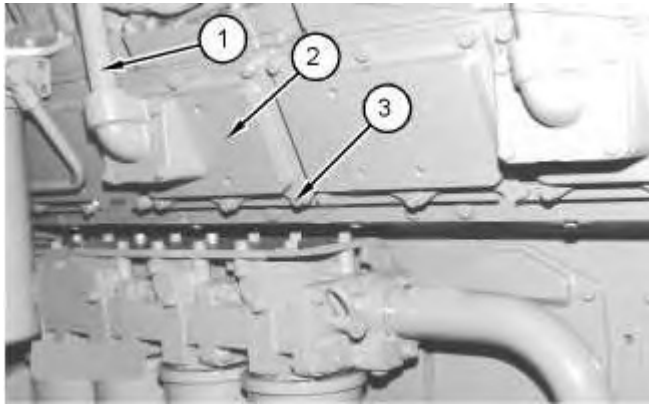

Illustration 17

g01007161

15. Position covers (2) and install bolts (3) on both sides of the engine.
16. Install tube assemblies (1).

End By:

- a. Install the electronic control module. Refer to Disassembly and Assembly, "Electronic Control Module (ECM) and Personality Module (PM) - Remove and Install".
 - b. Install the speed/timing sensor. Refer to the Service Manual, "Electronic Troubleshooting" module.
 - c. Install the valve cover base. Refer to Disassembly and Assembly, "Valve Cover Base - Remove and Install".
-

<https://www.ebooklibonline.com>

Hello dear friend!

Thank you very much for reading.

Enter the link into your browser.

The full manual is available for immediate download.

<https://www.ebooklibonline.com>