

Product: EXCAVATOR

Model: 312B L EXCAVATOR 9FS

Configuration: 312B & 312B L Excavators 9FS00001-UP (MACHINE) POWERED BY 3054 Engine

Operation and Maintenance Manual 312B Excavator

Media Number -SEBU7549-00

Publication Date -01/03/2001

Date Updated -09/10/2001

s00037320

Foreword

SMCS - 6501-086; 6502-086; 6513-086

Literature Information

This manual should be stored in the operator's compartment in the literature holder or seat back literature storage area.

This manual contains safety information, operation instructions, transportation information, lubrication information and maintenance information.

Some photographs or illustrations in this publication show details or attachments that can be different from your machine. Guards and covers might have been removed for illustrative purposes.

Continuing improvement and advancement of product design might have caused changes to your machine which are not included in this publication. Read, study and keep this manual with the machine.

Whenever a question arises regarding your machine, or this publication, please consult your Cat dealer for the latest available information.

Safety

The safety section lists basic safety precautions. In addition, this section identifies the text and locations of warning signs and labels used on the machine.

Read and understand the basic precautions listed in the safety section before operating or performing lubrication, maintenance and repair on this machine.

Operation

The operation section is a reference for the new operator and a refresher for the experienced operator. This section includes a discussion of gauges, switches, machine controls, attachment controls, transportation and towing information.

Photographs and illustrations guide the operator through correct procedures of checking, starting, operating and stopping the machine.

Operating techniques outlined in this publication are basic. Skill and techniques develop as the operator gains knowledge of the machine and its capabilities.

Maintenance

The maintenance section is a guide to equipment care. The Maintenance Interval Schedule (MIS) lists the items to be maintained at a specific service interval. Items without specific intervals are listed under the "When Required" service interval. The Maintenance Interval Schedule lists the page number for the step-by-step instructions required to accomplish the scheduled maintenance. Use the Maintenance Interval Schedule as an index or "one safe source" for all maintenance procedures.

Maintenance Intervals

Use the service hour meter to determine servicing intervals. Calendar intervals shown (daily, weekly, monthly, etc.) can be used instead of service hour meter intervals if they provide more convenient servicing schedules and approximate the indicated service hour meter reading. Recommended service should always be performed at the interval that occurs first.

Under extremely severe, dusty or wet operating conditions, more frequent lubrication than is specified in the maintenance intervals chart might be necessary.

Perform service on items at multiples of the original requirement. For example, at every 500 service hours or 3 months, also service those items listed under every 250 service hours or monthly and every 10 service hours or daily.

California Proposition 65 Warning

Diesel engine exhaust and some of its constituents are known to the State of California to cause cancer, birth defects, and other reproductive harm.

Battery posts, terminals and related accessories contain lead and lead compounds. **Wash hands after handling.**

Certified Engine Maintenance

Proper maintenance and repair is essential to keep the engine and machine systems operating correctly. As the heavy duty off-road diesel engine owner, you are responsible for the performance of the required maintenance listed in the Owner Manual, Operation and Maintenance Manual, and Service Manual.

It is prohibited for any person engaged in the business of repairing, servicing, selling, leasing, or trading engines or machines to remove, alter, or render inoperative any emission related device or element of design installed on or in an engine or machine that is in compliance with the

regulations (40 CFR Part 89). Certain elements of the machine and engine such as the exhaust system, fuel system, electrical system, intake air system and cooling system may be emission related and should not be altered unless approved by Caterpillar.

Machine Capacity

Additional attachments or modifications may exceed machine design capacity which can adversely affect performance characteristics. Included would be stability and system certifications such as brakes, steering, and rollover protective structures (ROPS). Contact your Cat dealer for further information.

Cat Product Identification Number

Effective First Quarter 2001 the Cat Product Identification Number (PIN) has changed from 8 to 17 characters. In an effort to provide uniform equipment identification, Caterpillar and other construction equipment manufacturers are moving to comply with the latest version of the product identification numbering standard. Non-road machine PINs are defined by ISO 10261. The new PIN format will apply to all Cat machines and generator sets. The PIN plates and frame marking will display the 17 character PIN. The new format will look like the following:



Illustration 1

g00751314

Where:

1. Caterpillar's World Manufacturing Code (characters 1-3)
2. Machine Descriptor (characters 4-8)
3. Check Character (character 9)
4. Machine Indicator Section (MIS) or Product Sequence Number (characters 10-17). These were previously referred to as the Serial Number.

<https://www.ebooklibonline.com>

Hello dear friend!

Thank you very much for reading.

Enter the link into your browser.

The full manual is available for immediate download.

<https://www.ebooklibonline.com>

Machines and generator sets produced before First Quarter 2001 will maintain their 8 character PIN format.

Components such as engines, transmissions, axles, etc. and work tools will continue to use an 8 character Serial Number (S/N).

Product: EXCAVATOR

Model: 312B L EXCAVATOR 9FS

Configuration: 312B & 312B L Excavators 9FS00001-UP (MACHINE) POWERED BY 3054 Engine

Operation and Maintenance Manual 312B Excavator

Media Number -SEBU7549-00

Publication Date -01/03/2001

Date Updated -09/10/2001

i01503037

Model View Illustrations - Offset Boom

SMCS - 7000

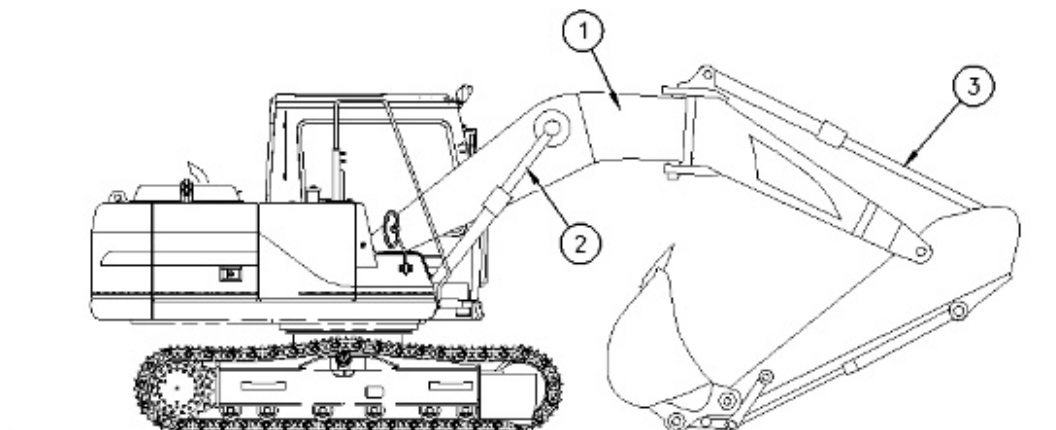

Illustration 2

g00780454

- (1) Offset boom
 - (2) Boom cylinder
 - (3) Stick cylinder
-

Product: EXCAVATOR

Model: 312B L EXCAVATOR 9FS

Configuration: 312B & 312B L Excavators 9FS00001-UP (MACHINE) POWERED BY 3054 Engine

Operation and Maintenance Manual 312B Excavator

Media Number -SEBU7549-00

Publication Date -01/03/2001

Date Updated -09/10/2001

i01503284

Working Ranges - Offset Boom

SMCS - 7000

Table 1

	Short Stick (2.1 m)	Medium Stick (2.6 m)	Long Stick (3.0 m)
Maximum digging depth	5.35 m	5.75 m	6.26 m
Maximum digging depth for a vertical wall	4.16 m	4.62 m	4.98 m
Maximum digging depth at a 2.44 m flat floor	5.06 m	5.49 m	6.01 m
Maximum reach at ground level	7.94 m	8.30 m	8.72 m
Maximum cutting height	8.10 m	8.31 m	8.44 m
Maximum loading height	5.79 m	5.99 m	6.14 m
Minimum loading height	2.64	2.25 m	1.74 m

Product: EXCAVATOR

Model: 312B L EXCAVATOR 9FS

Configuration: 312B & 312B L Excavators 9FS00001-UP (MACHINE) POWERED BY 3054 Engine

Operation and Maintenance Manual 312B Excavator

Media Number -SEBU7549-00

Publication Date -01/03/2001

Date Updated -09/10/2001

i01503170

Lifting Capacities - 312B Excavator with Offset Boom

SMCS - 7000



Illustration 1

g00586902

(H) Height

(F) Lifting capacity over the front or rear of the machine

(S) Lifting capacity over the side of the machine

(R) Reach

Table 1

312B Excavator with offset boom, 2.6 m stick, 0.54 m ³ bucket, and 500 mm track shoes ⁽¹⁾							
(R)		1.5 m		3.0 m		4.5 m	
(H)		(F)	(S)	(F)	(S)	(F)	(S)
7.5 m	kg						
6.0 m	kg						
4.5 m	kg					2890 ⁽²⁾	
3.0 m	kg			5180 ⁽²⁾		3660 ⁽²⁾	3190
1.5 m	kg			7260 ⁽²⁾	5270	4250	2870

0.0 m	kg			6150 ⁽²⁾	4870	3990	2640
-1.5 m	kg	4570 ⁽²⁾		6620 ⁽²⁾	4840	3890	2550
-3.0 m	kg	6470 ⁽²⁾		7110 ⁽²⁾	4970	3830	2580
-4.5 m	kg			5460 ⁽²⁾	5270		
312B Excavator with offset boom, 2.6 m stick, 0.54 m³ bucket, and 500 mm track shoes							
(R)		6.0 m		Maximum			
(H)		(F)	(S)	(F)	(S)	m	
7.5 m	kg			1430 ⁽²⁾		5.27	
6.0 m	kg			1270 ⁽²⁾		6.82	
4.5 m	kg	2750 ⁽²⁾	2030	1240 ⁽²⁾		7.67	
3.0 m	kg	2800	1940	1290 ⁽²⁾	1110	8.08	
1.5 m	kg	2660	1810	1410 ⁽²⁾	1040	8.15	
0.0 m	kg	2540	1700	1620 ⁽²⁾	1080	7.87	
-1.5 m	kg	2490	1650	1900	1250	7.22	
-3.0 m	kg						
-4.5 m	kg						

⁽¹⁾ "ISO 10567" "SAE J1097"

⁽²⁾ Capacity is limited by hydraulics rather than by a tipping load. The loads do not exceed 87 percent of hydraulic lifting capacity or 75 percent of tipping capacity. Weight of all lifting accessories must be subtracted from the lifting capacities.

Product: EXCAVATOR

Model: 312B L EXCAVATOR 9FS

Configuration: 312B & 312B L Excavators 9FS00001-UP (MACHINE) POWERED BY 3054 Engine

Operation and Maintenance Manual 312B Excavator

Media Number -SEBU7549-00

Publication Date -01/03/2001

Date Updated -09/10/2001

i01503133

Offset Boom Control

SMCS - 6521

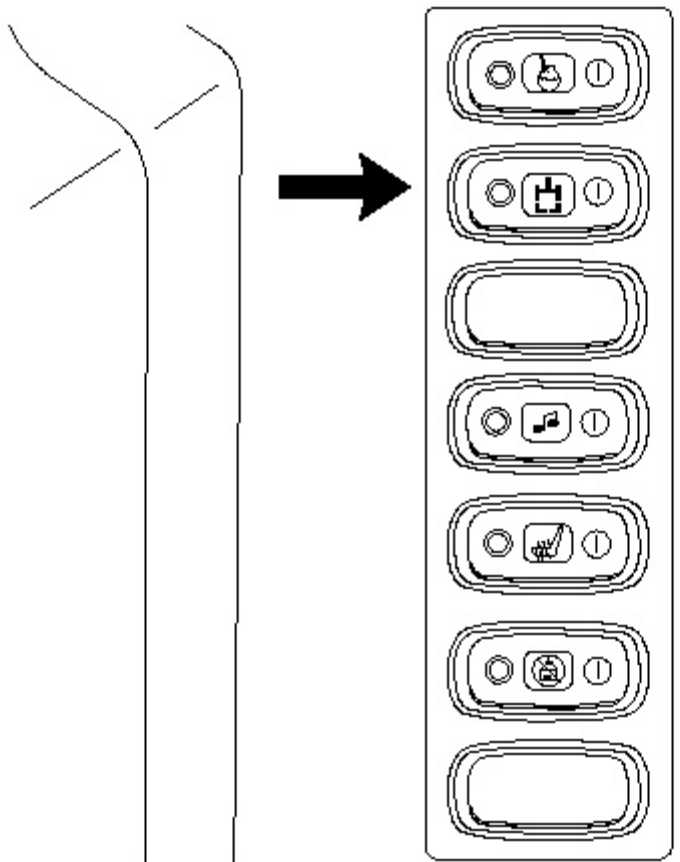

Illustration 1

g00775869

When a machine is equipped with auxiliary equipment, the pedal that operates the auxiliary equipment will also be the pedal that operates the offset boom. Since the auxiliary equipment and

the offset boom are operated by the same pedal, a switch that is located on the right side console must be switched to the function that is desired.

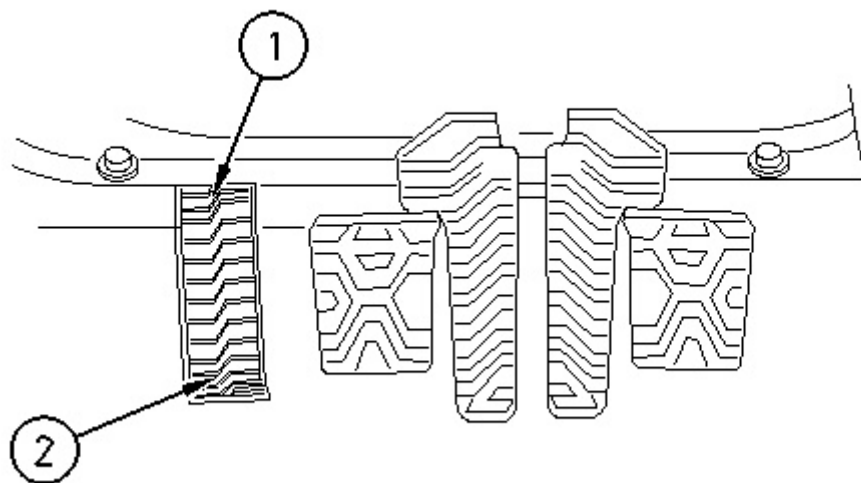

Illustration 2

g00775854

The movement of the offset boom is proportional when the offset boom is operated with the pedal.



Right Offset (1) - Push down on the front of the pedal in order to offset the boom to the right.



Left Offset (2) - Push down on the rear of the pedal in order to offset the boom to the left.

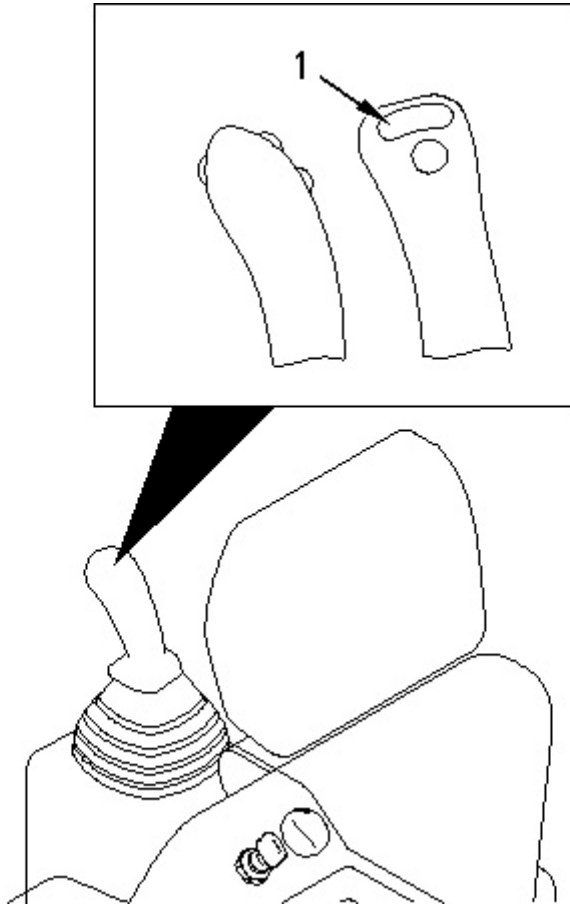

Illustration 3

g00781877

The offset boom can also be operated by using the top left button (1) on the right joystick. Pressing the left button moves the offset boom to the left. Boom movement is not proportional when the boom is operated with the joystick.

Pressing the button corresponds to a full pedal stroke. The offset boom will stop moving when the button is released.

Note: The offset boom cannot be moved to the right by using the button on the joystick.

Product: EXCAVATOR

Model: 312B L EXCAVATOR 9FS

Configuration: 312B & 312B L Excavators 9FS00001-UP (MACHINE) POWERED BY 3054 Engine

Operation and Maintenance Manual

312B Excavator

Media Number -SEBU7549-00

Publication Date -01/03/2001

Date Updated -09/10/2001

i01503125

Shipping Specifications

SMCS - 7000

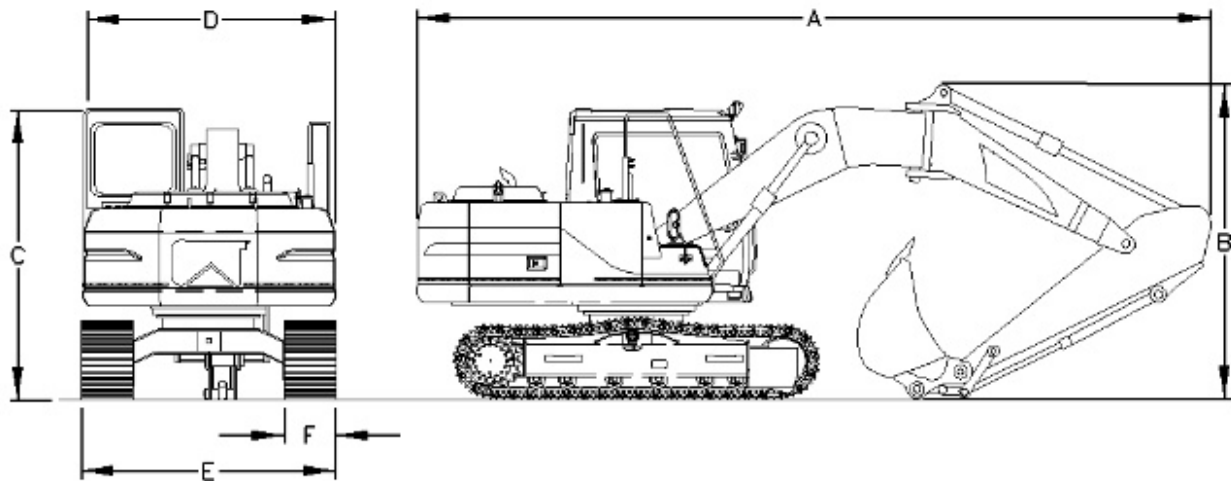

Illustration 1

g00779947

Table 1

312B Excavator with Offset Boom and 500 mm Track Shoes	
Approximate Weight with Medium Stick	13870 kg
Shipping Length with Short Stick (A)	7.78 m
Shipping Length with Medium Stick (A)	7.80 m
Shipping Length with Long Stick (A)	7.87 m
Shipping Height with Short Stick (B)	2.60 m
Shipping Height with Medium Stick (B)	2.67 m

Shipping Height with Long Stick (B) ⁽¹⁾	2.94 m
Height of Cab (C)	2.89 m
Shipping Width (D)	2.55 m
Width of Track (E)	2.49 m
Track Shoe Width (F)	500 mm

⁽¹⁾ The shipping height may be limited by the cab height.

Consult your Caterpillar dealer for specifications that are not included in Table 1.

Product: EXCAVATOR

Model: 312B L EXCAVATOR 9FS

Configuration: 312B & 312B L Excavators 9FS00001-UP (MACHINE) POWERED BY 3054 Engine

Operation and Maintenance Manual 312B & 312B L EXCAVATORS

Media Number -SEBU7086-00

Publication Date -01/10/1997

Date Updated -20/08/2015

Foreword

SMCS - 7000

Literature Information

This manual should be stored in the operator's compartment in the literature holder or seat back literature storage area.

This manual contains safety information, operation instructions, transportation information, lubrication information and maintenance information.

Some photographs or illustrations in this publication show details or attachments that can be different from your machine. Guards and covers might have been removed for illustrative purposes.

Continuing improvement and advancement of product design might have caused changes to your machine which are not included in this publication. Read, study and keep this manual with the machine.

Whenever a question arises regarding your machine, or this publication, please consult your Caterpillar dealer for the latest available information.

Safety

The safety section lists basic safety precautions. In addition, this section identifies the text and locations of warning signs and labels used on the machine.

Read and understand the basic precautions listed in the safety section before operating or performing lubrication, maintenance and repair on this machine.

Operation

The operation section is a reference for the new operator and a refresher for the experienced operator. This section includes a discussion of gauges, switches, machine controls, attachment controls, transportation and towing information.

Photographs and illustrations guide the operator through correct procedures of checking, starting, operating and stopping the machine.

Operating techniques outlined in this publication are basic. Skill and techniques develop as the operator gains knowledge of the machine and its capabilities.

Maintenance

The maintenance section is a guide to equipment care. The illustrated, step-by-step instructions are grouped by service intervals. Items without specific intervals are listed under the when required interval. Items in the maintenance intervals chart are referenced to detailed instructions that follow.

Maintenance Intervals

Use the service hour meter to determine servicing intervals. Calendar intervals shown (daily, weekly, monthly, etc) can be used instead of service hour meter intervals if they provide more convenient servicing schedules and approximate the indicated service hour meter reading. Recommended service should always be performed at the interval that occurs first.

Under extremely severe, dusty or wet operating conditions, more frequent lubrication than is specified in the maintenance intervals chart might be necessary.

Perform service on items at multiples of the original requirement. For example, at every 500 service hours or 3 months, also service those items listed under every 250 service hours or monthly and every 10 service hours or daily.

California Proposition 65

Diesel engine exhaust and some of its constituents are known to the State of California to cause cancer, birth defects, and other reproductive harm.

Product: EXCAVATOR

Model: 312B L EXCAVATOR 9FS

Configuration: 312B & 312B L Excavators 9FS00001-UP (MACHINE) POWERED BY 3054 Engine

Operation and Maintenance Manual 312B & 312B L EXCAVATORS

Media Number -SEBU7086-00

Publication Date -01/10/1997

Date Updated -20/08/2015

Warning Signs And Labels

SMCS - 7000

SMCS Code: 7000; 7405

There are several specific warning signs on this machine. The exact location of the hazards and the description of the hazards are reviewed in this section. Please become familiarized with all warning signs.

Make sure that all of the warning signs are legible. Clean the warning signs or replace the warning signs if you cannot read the words. Replace the illustrations if the illustrations are not visible. When you clean the warning signs, use a cloth, water and soap. Do not use solvent, gasoline, or other harsh chemicals to clean the safety signs. Solvents, gasoline, or harsh chemicals could loosen the adhesive that secures the warning sign. Loose adhesive will allow the warning sign to fall.

Replace any safety sign that is damaged, or missing. If a safety sign is attached to a part that is replaced, install a safety sign on the replacement part. Any Caterpillar dealer can provide new safety signs.

Do Not Operate

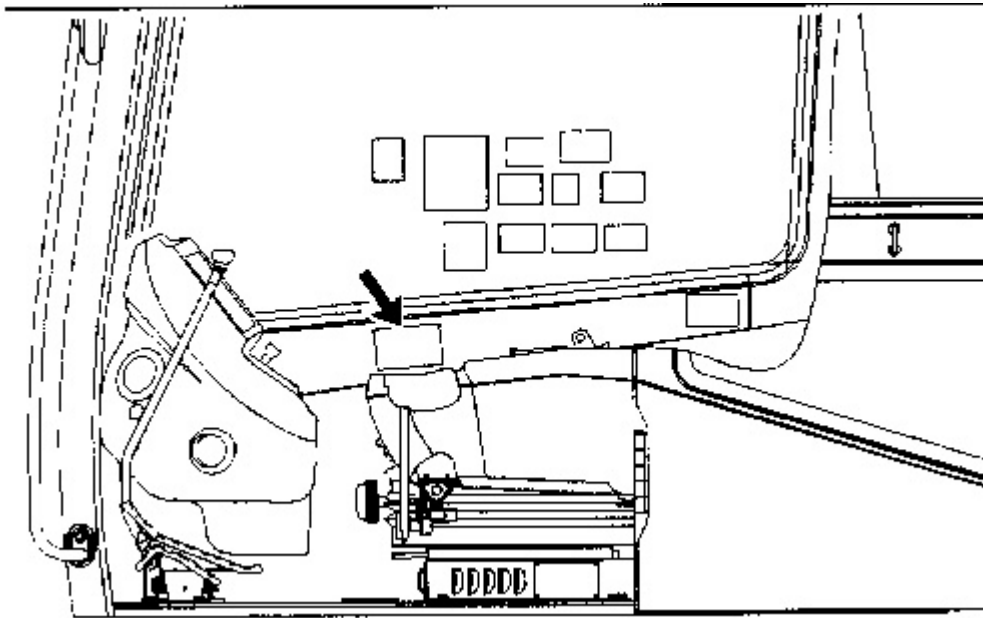
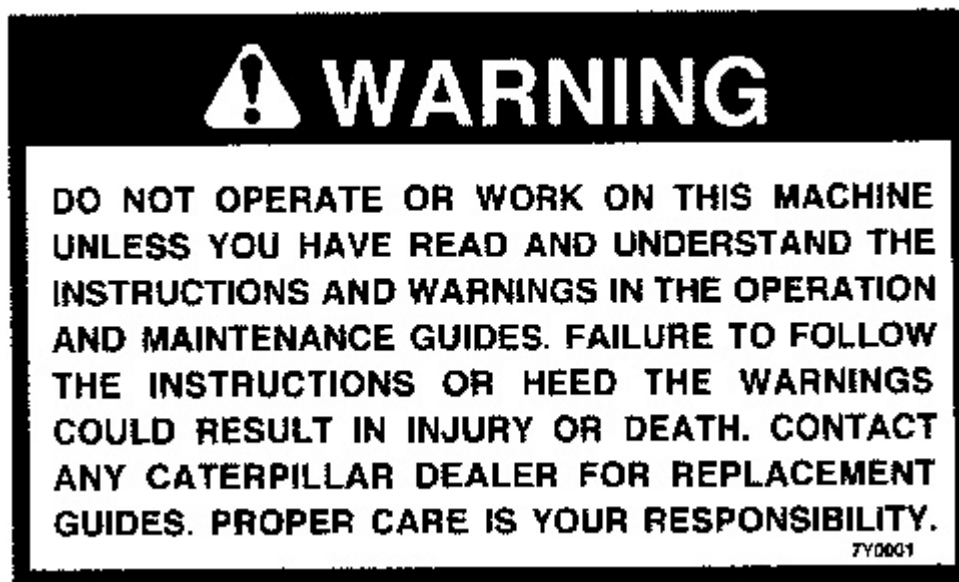

Illustration 1

This warning label is positioned in the cab.



DO NOT OPERATE OR WORK ON THIS MACHINE UNLESS YOU HAVE READ AND UNDERSTAND THE INSTRUCTIONS AND WARNINGS IN THE OPERATION AND MAINTENANCE MANUALS. FAILURE TO FOLLOW THE INSTRUCTIONS OR HEED THE WARNINGS COULD RESULT IN INJURY OR DEATH. CONTACT ANY CATERPILLAR DEALER FOR REPLACEMENT MANUALS. PROPER CARE IS YOUR RESPONSIBILITY.

Height And Reach Of Machine

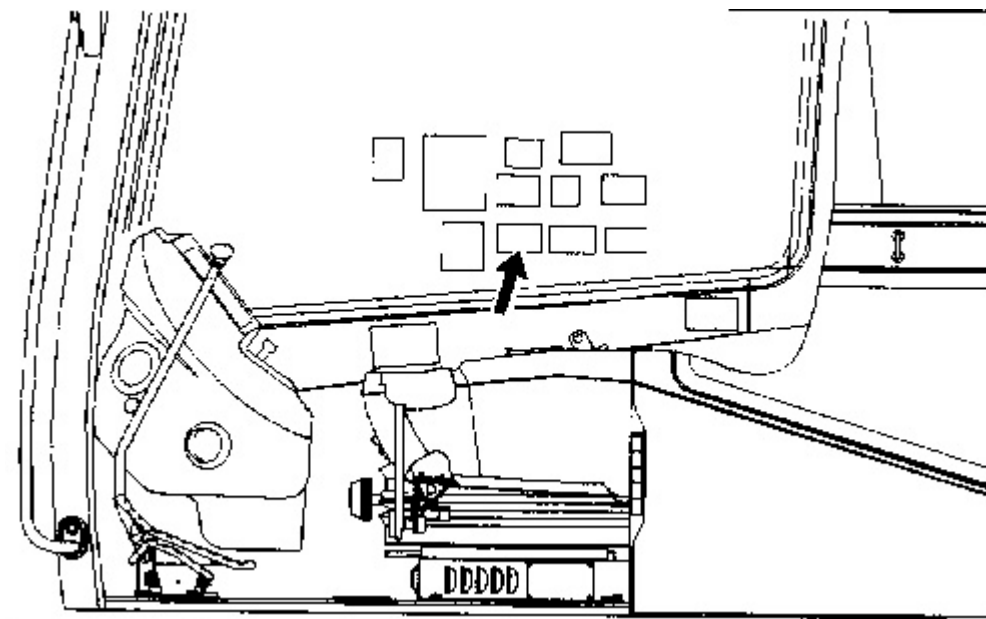
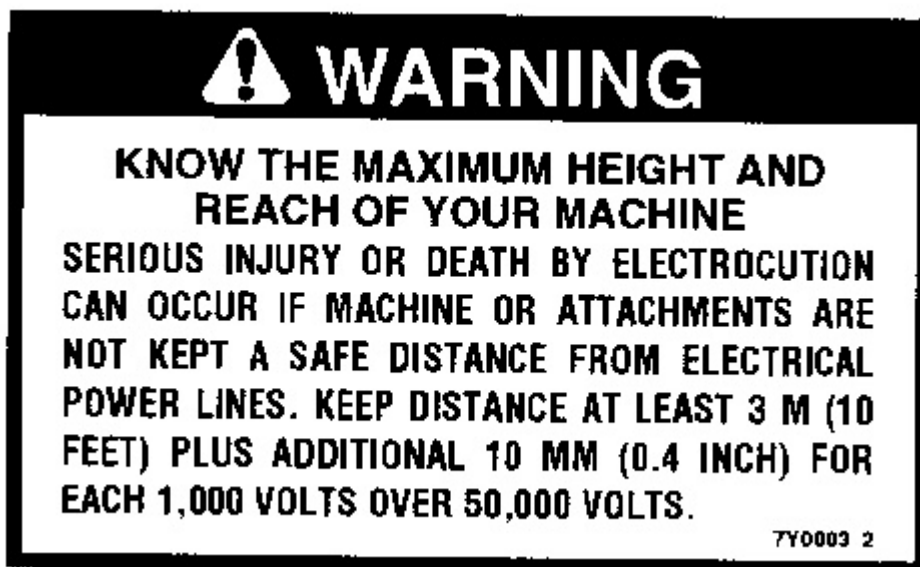

Illustration 2

This warning label is positioned in the cab.



KNOW THE MAXIMUM HEIGHT AND REACH OF YOUR MACHINE. SERIOUS INJURY OR DEATH BY ELECTROCUTION CAN OCCUR IF MACHINE OR ATTACHMENTS ARE NOT KEPT A SAFE DISTANCE FROM ELECTRICAL POWER LINES. KEEP DISTANCE AT LEAST 3 M (10 FEET) PLUS ADDITIONAL 10 MM (0.4 INCH) FOR EACH 1,000 VOLTS OVER 50,000 VOLTS.

Improper Connections For Jump Start Cables

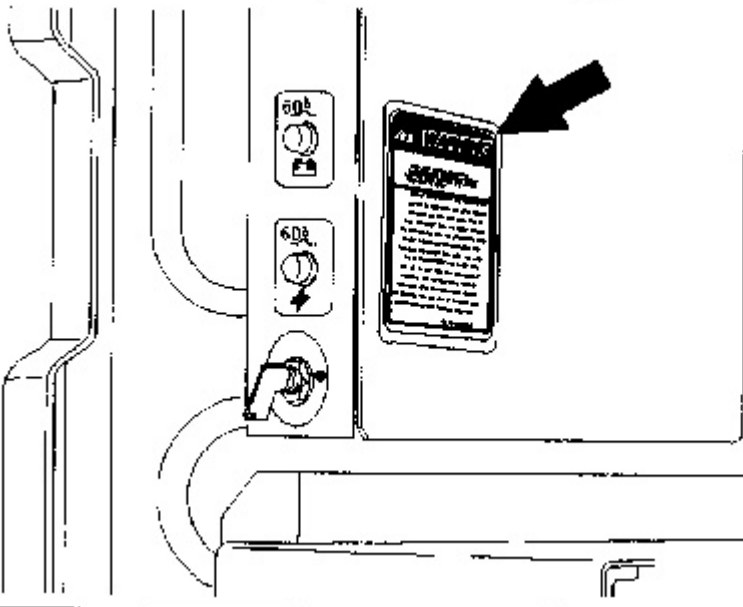

Illustration 3

This warning label is positioned on the circuit breaker panel.



Suggest:

For more complete manuals. Please go to the home page.

<https://www.ebooklibonline.com>

If the above button click is invalid. Please download this document first, and then click the above link to download the complete manual.

Thank you so much for reading

 **WARNING**

IMPROPER JUMPER CABLE CONNECTIONS CAN CAUSE EXPLOSION RESULTING IN PERSONAL INJURY.

BATTERIES MAY BE LOCATED IN SEPARATE COMPARTMENTS. WHEN USING JUMPER CABLES, ALWAYS CONNECT POSITIVE (+) CABLE TO POSITIVE (+) TERMINAL OF BATTERY CONNECTED TO STARTER SOLENOID AND NEGATIVE (-) CABLE FROM EXTERNAL SOURCE TO STARTER NEGATIVE (-) TERMINAL (IF MACHINE NOT EQUIPPED WITH STARTER NEGATIVE TERMINAL, CONNECT TO ENGINE BLOCK.) FOLLOW PROCEDURE IN THE OPERATION MANUAL.

6V-4611 4

 **WARNING**

IMPROPER JUMPER CABLE CONNECTIONS CAN CAUSE EXPLOSION RESULTING IN PERSONAL INJURY.

BATTERIES MAY BE LOCATED IN SEPARATE COMPARTMENTS. WHEN USING JUMPER CABLES, ALWAYS CONNECT POSITIVE (+) CABLE TO POSITIVE (+) TERMINAL OF BATTERY CONNECTED TO STARTER SOLENOID AND NEGATIVE (-) CABLE FROM EXTERNAL SOURCE TO STARTER NEGATIVE (-) TERMINAL (IF MACHINE NOT EQUIPPED WITH STARTER NEGATIVE TERMINAL, CONNECT TO ENGINE BLOCK.) FOLLOW PROCEDURE IN THE OPERATION MANUAL.

Relieve Hydraulic Tank Pressure

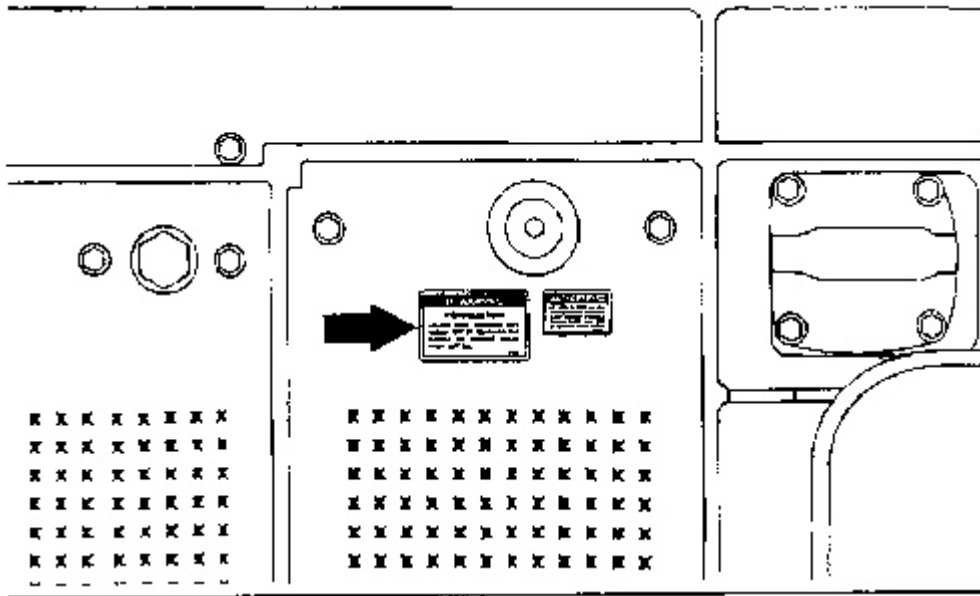

Illustration 4

This warning label is located on the top of the hydraulic tank.



Relieve tank pressure with engine off by removing cap slowly to prevent burns from hot oil.

<https://www.ebooklibonline.com>

Hello dear friend!

Thank you very much for reading.

Enter the link into your browser.

The full manual is available for immediate download.

<https://www.ebooklibonline.com>