

Product: EXCAVATOR

Model: 213B EXCAVATOR 1EJ

Configuration: 213B EXCAVATOR TRACK TYPE 1EJ00001-UP (MACHINE) POWERED BY 3116 ENGINE

Operation and Maintenance Manual 213B LC TRACK-TYPE EXCAVATOR

Media Number -SEBU6049-00

Publication Date -01/04/1989

Date Updated -11/10/2001

Foreword

SMCS - 7606

This guide contains safety precautions, operation instructions and lubrication and maintenance information.

The operation section is a reference for the new operator and a refresher for the experienced one. Read - study - and keep it handy.

Photographs or illustrations guide the operator through correct procedures of checking, starting, operating and stopping the machine.

Operating techniques outlined in this publication are basic. Skill and techniques develop as the operator gains knowledge of the machine and its capabilities.

The maintenance section is a guide to equipment care. The illustrated, step-by-step instructions are grouped by servicing intervals. Items without specific intervals are listed under "When Required." Items in the "Maintenance Intervals" are referenced to detailed instructions that follow.

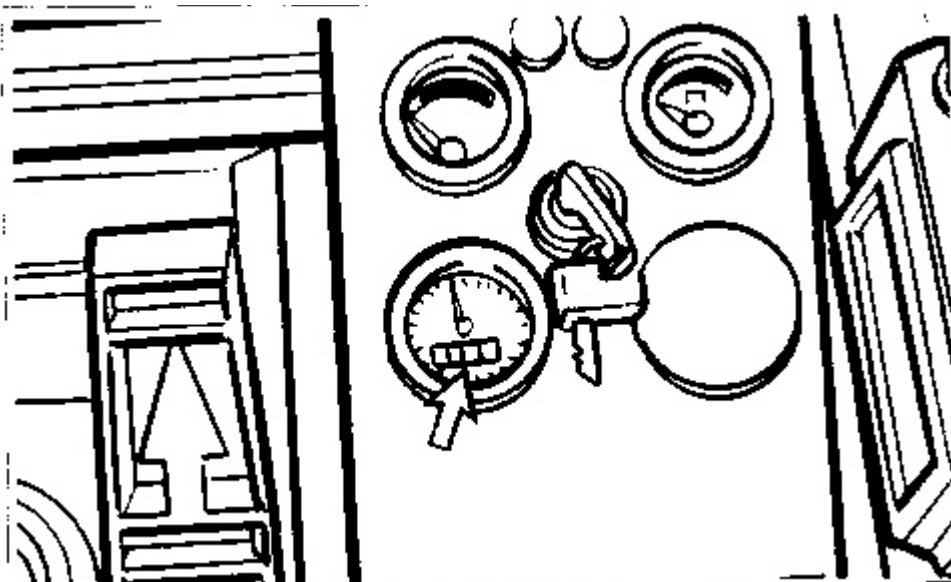

Use the service hour meter to determine servicing intervals. Calendar intervals shown (daily, weekly, monthly, etc.) may be used instead of service hour meter intervals if they provide more

convenient servicing schedules and approximate the indicated service hour meter reading. Recommended service should always be performed at the interval that occurs first.

Under extremely severe, dusty or wet operating conditions, more frequent lubrication than is specified in the "Maintenance Intervals" may be necessary.

Perform service on items at multiples of the original requirement. For example, at Every 500 Service Hours or 3 Months, also service those items listed under Every 250 Service Hours or Monthly, Every 50 Service Hours or Weekly and Every 10 Service Hours or Daily.

Some photographs or illustrations in this publication show details or attachments that may be different from your machine. Also, guards and covers may have been removed for illustrative purposes.

Continuing improvement and advancement of product design may have caused changes to your machine which are not included in this publication.

Whenever a question arises regarding your machine, or this publication, please consult your Caterpillar dealer for the latest available information.

Product: EXCAVATOR

Model: 213B EXCAVATOR 1EJ

Configuration: 213B EXCAVATOR TRACK TYPE 1EJ00001-UP (MACHINE) POWERED BY 3116 ENGINE

Operation and Maintenance Manual 213B LC TRACK-TYPE EXCAVATOR

Media Number -SEBU6049-00

Publication Date -01/04/1989

Date Updated -11/10/2001

Safety

SMCS - 7606

Warning Signs and Labels

There are several specific safety signs on your machine. Their exact location and description of the hazard are reviewed in this section. Please take the time to familiarize yourself with these safety signs.

Make sure that you can read all safety signs. Clean or replace these if you cannot read the words or see the pictures. When cleaning the labels use a cloth, water and soap. Do not use solvent, gasoline, etc.

You must replace a label if it is damaged, missing or cannot be read. If a label is on a part that is replaced, make sure a new label is installed on the replaced part. See your Caterpillar dealer for new labels.



Do not operate or work on this machine unless you have read and understand the instructions and warnings in the Operation and Maintenance guides. Failure to follow the instructions or heed the warnings could result in injury or death. Contact any Caterpillar dealer for replacement guides. Proper care is your responsibility.

<https://www.ebooklibonline.com>

Hello dear friend!

Thank you very much for reading.

Enter the link into your browser.

The full manual is available for immediate download.

<https://www.ebooklibonline.com>

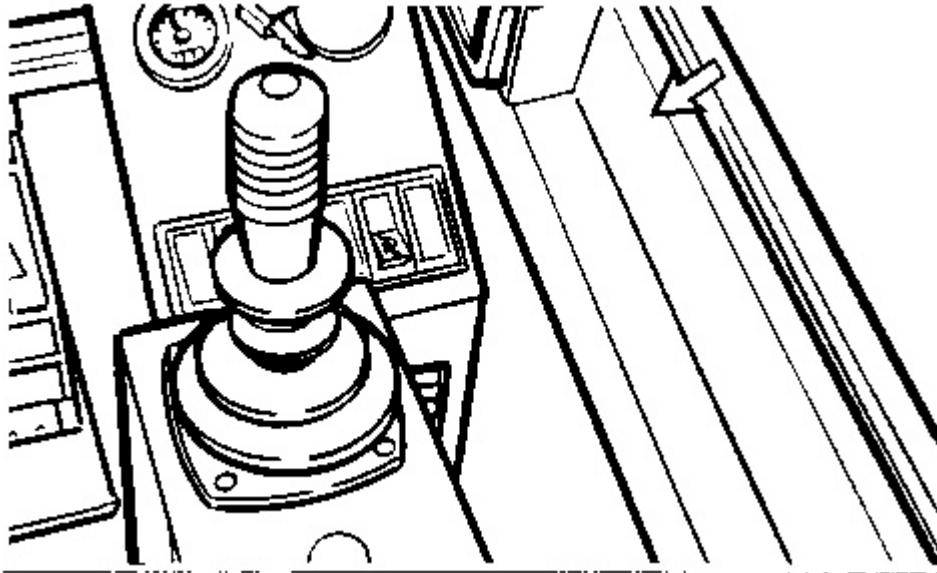

Located in the operator's compartment.

 **WARNING**

Swing Lock Control Swing lock must be engaged before shipping machine. If lock is not engaged, upper structure can swing, resulting in possible personal injury.

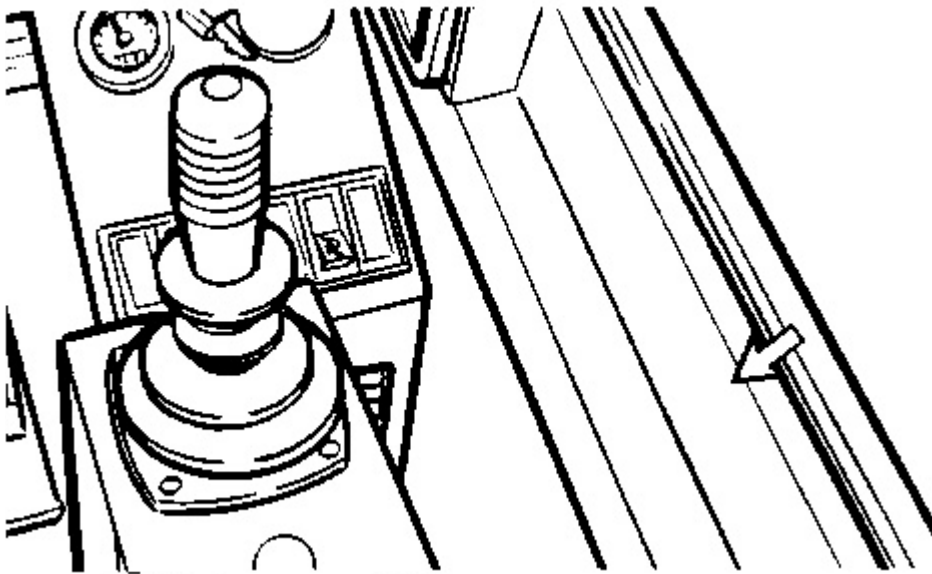

Located in the operator's compartment.

 **WARNING**

Know the maximum height and reach of your machine. Serious injury or death by electrocution can occur if machine or attachments are not kept a safe distance from electrical power lines. Keep distance at least 3 m (10 feet) plus additional 10 mm (0.4 inch) for each 1,000 volts over 50,000 volts.

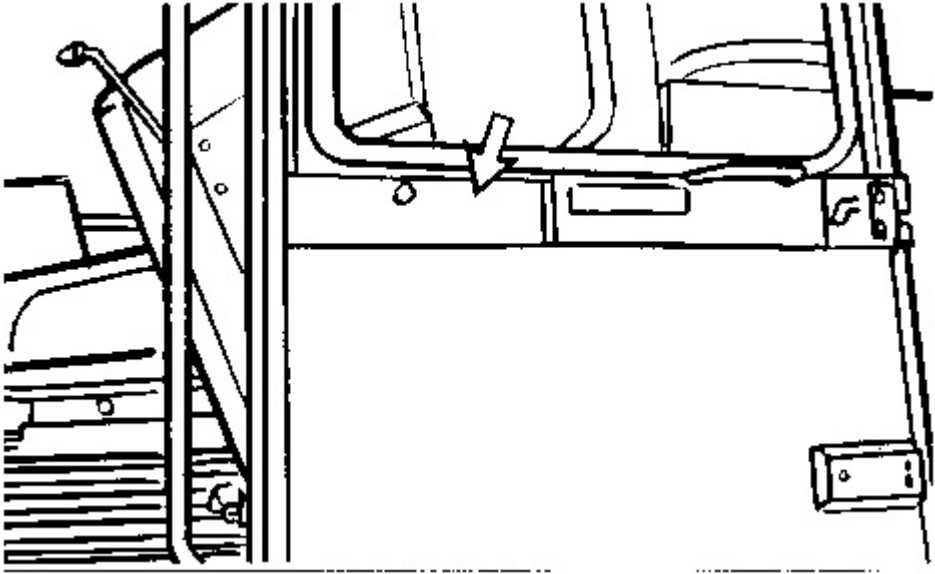

Located on the door.



WARNING

HIGH PRESSURE CYLINDER Do not remove any parts until all pressure has been relieved to avoid possible personal injury. Relieve pressure by opening relief valve 3 turns maximum. See "Maintenance" Guide for track adjustment procedure.

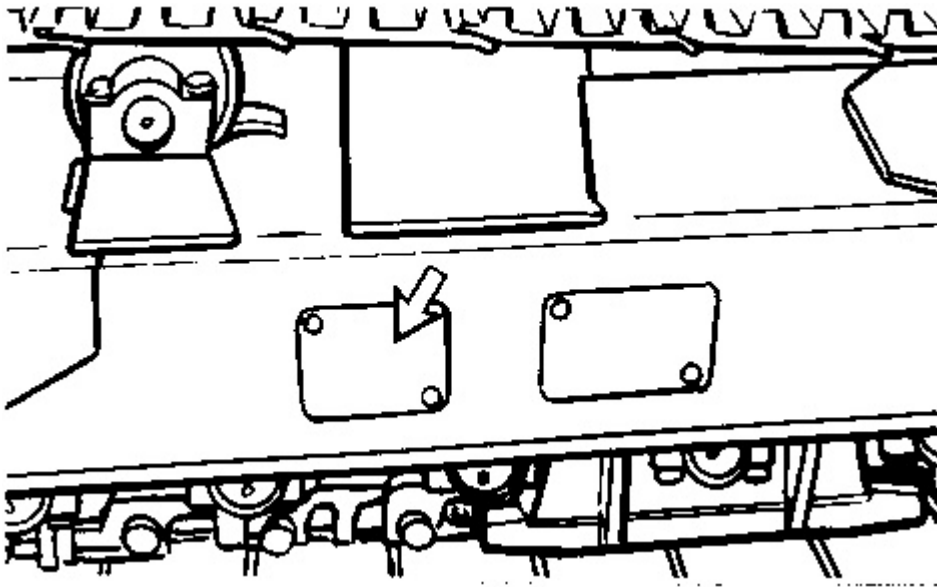

Located on both track roller frames.

⚠ WARNING

Improper jumper cable connections can cause an explosion resulting in personal injury. Batteries may be located in separate compartments. When using jumper cables always connect positive (+) cable to positive (+) terminal of battery connected to starter solenoid and negative (-) cable from external source to starter negative (-) terminal. (If machine not equipped with starter negative terminal, connect to engine block.)

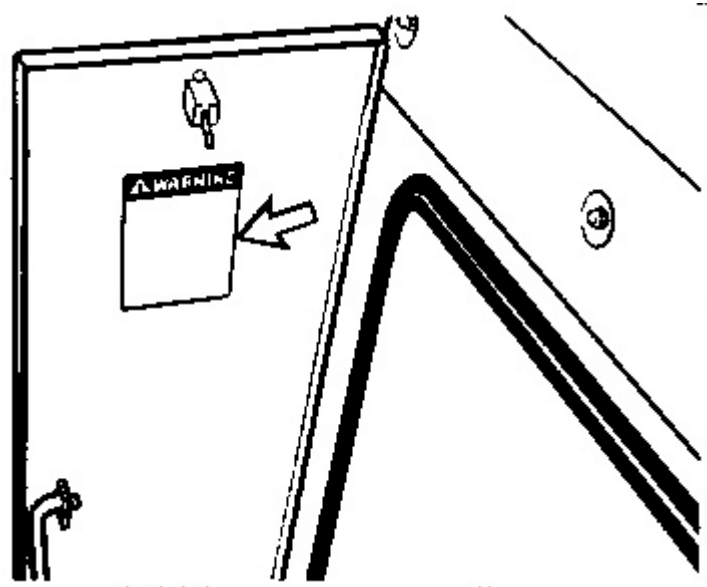

Located in the battery compartment.

To remove rear window, pull ring and push out.

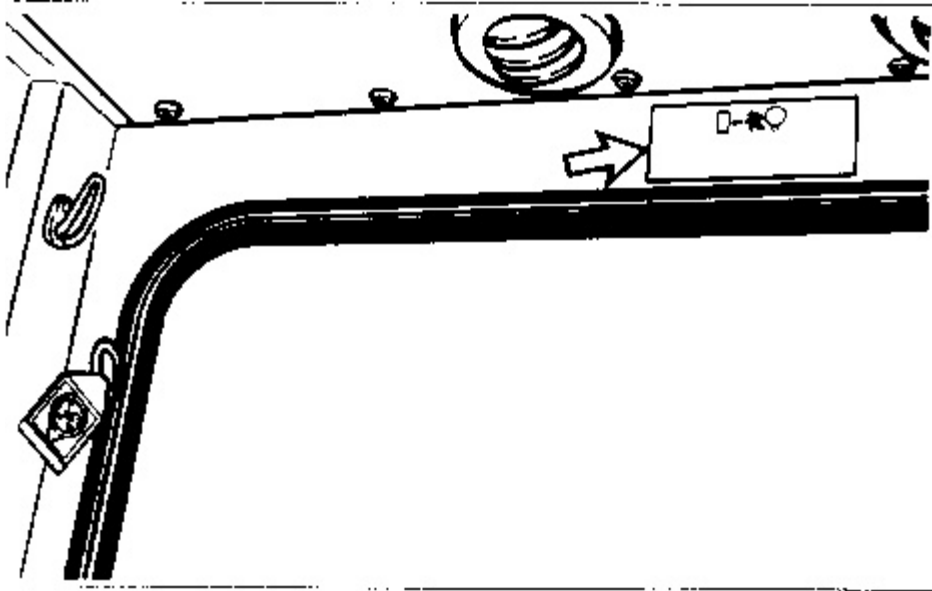

Located above the rear window.

General Hazard Information



Attach "DO NOT OPERATE" or similar warning tag to start switch or controls before servicing or repairing the machine. These tags, Form SEHS7332, are available from your Caterpillar dealer.

Know the width of your implements so proper clearance can be maintained when operating near fences, boundary obstacles, etc.

Perform all maintenance unless otherwise specified as follows:

- * Park the machine on level ground.
- * The swing lock pin locked.
- * The implements lowered to the ground.
- * The hydraulic armrest control pulled up to the disengaged position.
- * The engine stopped.
- * The start switch key removed.
- * The disconnect switch off and the key removed.

With the parking brake system disconnected, the machine has no brakes. To prevent unexpected machine movement, block the tracks before the parking brake and transmission are disconnected.

Use the front windshield or rear window as a secondary exit if the door is blocked.

Wear a hard hat, protective glasses and other protective equipment as required by job conditions.

Do not wear loose clothing or jewelry that can catch on controls or other parts of the machine.

Make certain all protective guards and covers are secured in place on the machine.

Keep the machine, especially the cab floor, deck, walkways and steps, free of foreign material, such as debris, oil, tools and other items which are not part of the machine.

Secure all loose items such as lunch boxes, tools and other items which are not part of the machine.

Know the hand signals and who gives them. Accept signals from one person only.

Never put maintenance fluids into glass containers.

Report all needed repairs.

Do not allow unauthorized personnel on the machine.

Pressure air can cause personal injury. When using pressure air for cleaning, wear a protective face shield and protective clothing.

Asbestos Information

Caution should be used to avoid breathing dust that may be generated when handling components containing asbestos fibers. If this dust is inhaled, it can be hazardous to your health. Components in Caterpillar products that may contain asbestos fibers are brake pads, brake band and lining assemblies, clutch plates and some gaskets. The asbestos used in these components is usually bound in a resin or sealed in some way. Normal handling is not hazardous as long as airborne dust which contains asbestos is not generated.

If dust which may contain asbestos is present, there are several common sense guidelines that should be followed.

1. Never use compressed air for cleaning.
2. Avoid brushing or grinding of asbestos containing materials.
3. For clean up, use wet methods or a vacuum equipped with a high efficiency particulate air (HEPA) filter.
4. Use exhaust ventilation on permanent machining jobs.
5. Wear an approved respirator if there is no other way to control the dust.
6. Comply with applicable rules and regulations for the work place (for example in the U.S.A., OSHA requirements as set forth in 29 CFR 1910.1001).
7. Follow environmental rules and regulations for disposal of asbestos.

8. Avoid areas where asbestos particles may be in the air.

Crushing or Cutting Prevention

Never attempt adjustments while the machine is moving or the engine is running unless otherwise specified.

Support equipment and implements properly when working beneath them. Do not depend on hydraulic cylinders to hold it up. Any implement can fall if a control is moved, or if a hydraulic line breaks.

Where there are implement linkages, the clearance in the linkage area will increase or decrease with movement of the implement.

Stay clear of all rotating and moving parts.

Keep objects away from moving fan blades. They will throw or cut any object or tool that falls or is pushed into them.

Do not use a kinked or frayed wire rope cable. Wear gloves when handling the wire rope cable.

Retainer pins, when struck with force, can fly out and injure nearby persons.

Wear protective glasses when striking a retainer pin to avoid injury to your eyes.

Chips or other debris can fly off objects when struck. Make sure no one can be injured by flying debris before striking any object.

Falling Object Protective Structure (FOPS)

This is an attachment guard located on and secured to the top of the cab.

To avoid possible weakening of this FOPS, consult a Caterpillar dealer before altering the FOPS in any way. The protection offered by this FOPS will be impaired if it or the cab has been subjected to structural damage or has been involved in an overturn incident.

Burn Prevention

At operating temperature, the engine coolant is hot and under pressure. The radiator and all lines to heaters or the engine contain hot water or steam. Any contact can cause severe burns.

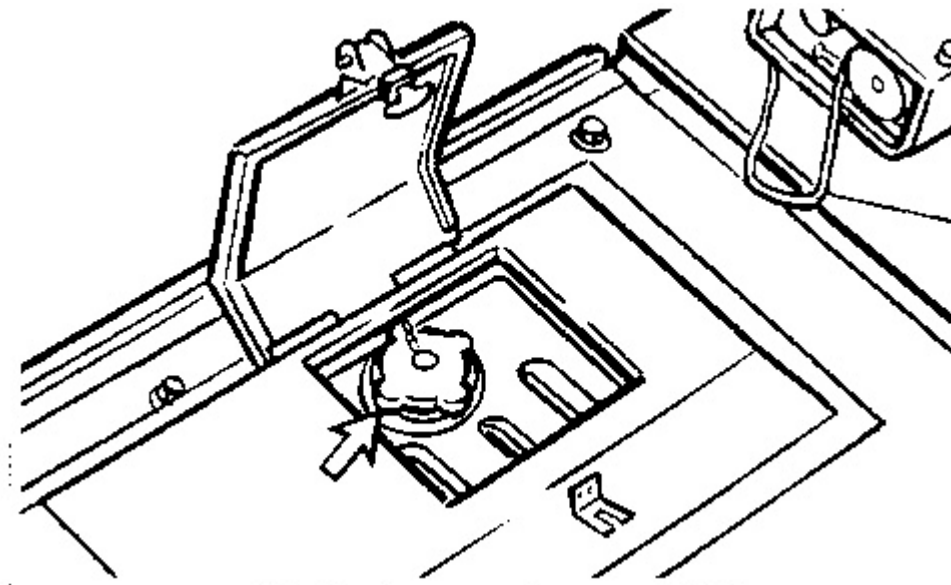

Check the coolant level only after the engine has been stopped and the filler cap is cool enough to remove with your bare hand.

Remove the cooling system filler cap slowly to relieve pressure.

Cooling system conditioner contains alkali that can cause personal injury. Avoid contact with the skin and eyes and do not drink.

Allow cooling system components to cool before draining.

Hot oil and components can cause personal injury. Do not allow hot oil or components to contact the skin.

At operating temperature, the hydraulic tank is hot and can be under pressure.

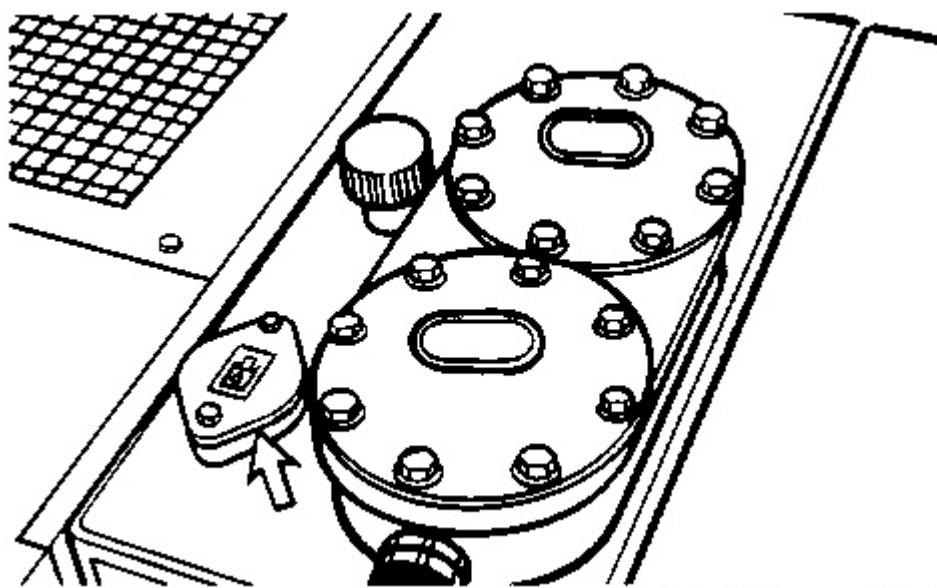

Remove the hydraulic tank filler cover only after the engine has been stopped and the filler cover is cool enough to remove with your bare hand.

Remove the hydraulic tank filler cover slowly to relieve pressure.

Relieve all pressure in air, oil, fuel or cooling systems before any lines, fittings or related items are disconnected or removed.

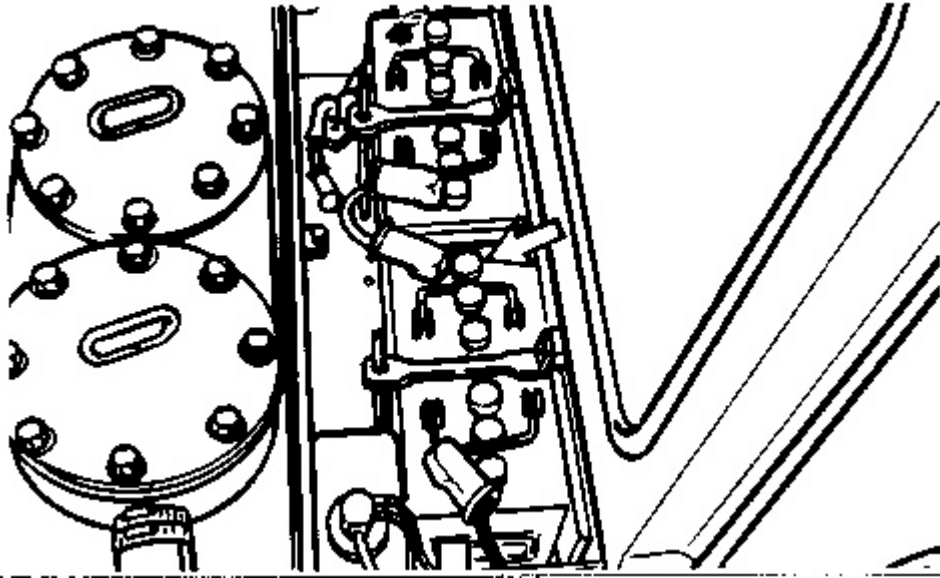

Battery electrolyte contains acid that can cause injury. Avoid contact with the skin and eyes.

Fire or Explosion Prevention

All fuels, most lubricants and some coolant mixtures are flammable.

Do not smoke while refueling or in a refueling area.

Do not smoke in areas where batteries are charged, or where flammable materials are stored.

Batteries may be located in separate compartments. When using jumper cables always connect positive (+) cable to positive (+) terminal of battery connected to starter solenoid and negative (-) cable from external source to starter negative (-) terminal. (If not equipped with starter negative terminal, connect to engine block.)

See the "Starting the Engine" section of this guide for specific instructions.

Clean and tighten all electrical connections. Check daily for loose or frayed electrical wires. Have all loose or frayed electrical wires tightened, repaired or replaced before operating the machine.

Keep all fuels and lubricants stored in properly marked containers and away from all unauthorized persons.

Store all oily rags or other flammable material in a protective container, in a safe place.

Do not weld or flame cut on pipes or tubes that contain flammable fluids. Clean them thoroughly with nonflammable solvent before welding or flame cutting on them.

Remove all flammable materials such as fuel, oil and other debris before they accumulate on the machine.

Do not expose the machine to flames, burning brush, etc., if at all possible.

Shields, which protect hot exhaust components from oil or fuel spray in the event of a line, tube or seal failure, must be installed correctly.

Have a fire extinguisher available and know how to use it. Inspect and have it serviced as recommended on its instruction plate.

Ether

Ether is flammable. Do not smoke while changing ether cylinders.

Use ether only in well ventilated areas.

Keep ether cylinders out of the reach of unauthorized persons.

Do not store replacement ether cylinders in living areas or in the operator's compartment.

Do not store ether cylinders in direct sunlight. Discard cylinders in a safe place. Do not puncture or burn cylinders.

Lines, Tubes and Hoses

Do not bend or strike high pressure lines. Do not install bent or damaged lines, tubes or hoses.

Repair any loose or damaged fuel and oil lines, tubes and hoses. Leaks can cause fires.

Check lines, tubes and hoses carefully. Do not use your bare hand to check for leaks. Use a board or cardboard to check for leaks.

Escaping fluid under pressure, even a pin-hole size leak, can penetrate body tissue, causing serious injury, and possible death. If fluid is injected into your skin, it must be removed surgically by a doctor familiar with this type of injury within a few hours.

Tighten all connections to the recommended torque. Replace if any of the following conditions are found:

1. End fittings damaged or leaking.
2. Outer covering chafed or cut and wire reinforcing exposed.
3. Outer covering ballooning locally.
4. Evidence of kinking or crushing of the flexible part of hose.
5. Armouring embedded in the outer cover.
6. End fittings displaced.

Make sure that all clamps, guards and heat shields are installed correctly to prevent vibration, rubbing against other parts, and excessive heat during operation.

Mounting and Dismounting

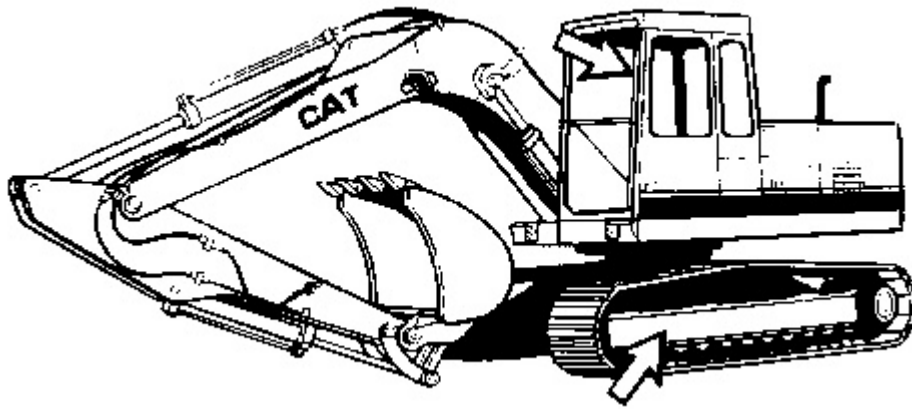

Mount and dismount the machine only where steps and/or handholds are provided.

Use both hands and face the machine, when mounting and dismounting.

Never get on or off a moving machine. Never jump off the machine.

Do not try to climb on or off the machine when carrying tools or supplies. Use a hand line to pull equipment up onto the platform.

Engine Starting Preparation

Start the engine only from the operator's station. Never short across the starter terminals or across the batteries, as this could bypass the engine neutral-start system as well as damage the electrical system.

Inspect the condition of the seat belt and mounting hardware. Replace any damaged or worn parts. Replace the seat belt regardless of appearance, after three years of use.

Adjust the seat so that full pedal travel can be obtained with the operator's back against the seat back.

Make sure the machine is equipped with a lighting system as required by conditions.

Make sure all lights are working properly.

Make sure no one is working on, underneath or close to the machine before starting the engine or beginning to move the machine. Make sure the area is free of personnel.

Engine Starting



Do not start the engine or move any of the controls if there is a "DO NOT OPERATE" or similar warning tag attached to the start switch or controls.

Move all attachment controls to the HOLD position before starting the engine.

The left armrest must be raised to allow the engine starter circuit to activate when the key is turned to the START position. The raised armrest also disengages the hydraulic controls except steering.

Start and operate the engine in a well ventilated area only. In an enclosed area, vent the exhaust to the outside.

Machine Operating Preparation

Clear all personnel from the machine and the area.

Clear all obstacles from the path of the machine. Beware of hazards such as wires, ditches, etc.

Be sure all windows are clean. Secure the doors and windows in either the open or closed position.

For best vision, especially close to the machine, adjust the rear view mirrors.

Make sure the machine horn, the backup alarm (if equipped) and all other warning devices are working properly.

Fasten the seat belt securely.

Check for proper operation of all controls and protective devices while moving slowly in an open area.

Machine Operation

Operate the machine only while seated.

Operate the controls only with the engine running.

The operator must satisfy himself that no one will be endangered before moving the machine.

Do not allow riders on the machine unless additional seat, seat belt and Falling Object Protective Structure (FOPS) are provided.

Report any needed repairs noted during operation.

Carry implements close to the ground, approximately 40 cm (15 inch) above ground level, for normal travel. As the machine ground speed increases, move linkage into a tucked position close to the machine.

Stay a safe distance from the edge of cliffs, overhangs and slide areas.

Be careful to avoid the condition which could lead to tipping when working on hills, banks or slopes, and when crossing ditches, ridges or other obstructions.

Keep the machine under control and do not work it over its capacity.

Be sure hitch points and the towing device are adequate.

Connect trailing equipment to a drawbar or hitch only.

Never straddle a wire rope cable or similar device, nor allow others to do so.

No personnel should be between the machine and trailing equipment when maneuvering to connect them. Block the tongue or hitch of trailing equipment to align it with the drawbar or hitch.

Watch boom clearances when moving the machine. Uneven ground can cause the boom to move from side to side or up and down.

Know the maximum height and reach of your machine.

Always keep the Falling Object Protective Structure (FOPS) (if equipped) installed when operating the machine.

Work up and down slopes, rather than sideways, whenever possible.

Machine Parking

Park on a level surface if possible. If necessary to park on a grade, block the machine.

Lower all implements to the ground and apply slight down pressure.

Raise the left armrest up to disengage the hydraulics.

Turn the start switch key to the OFF position to stop the engine.

Remove the start switch key and the disconnect switch key.

Product: EXCAVATOR

Model: 213B EXCAVATOR 1EJ

Configuration: 213B EXCAVATOR TRACK TYPE 1EJ00001-UP (MACHINE) POWERED BY 3116 ENGINE

Operation and Maintenance Manual 213B LC TRACK-TYPE EXCAVATOR

Media Number -SEBU6049-00

Publication Date -01/04/1989

Date Updated -11/10/2001

Towing

SMCS - 7606



WARNING

Personal injury or death could result when towing a disabled machine incorrectly.

Block the machine to prevent movement before releasing the brakes. The machine can roll free if it is not blocked.

Follow the recommendations below, to properly perform the towing procedure.

These towing instructions are for moving a disabled machine a short distance, only a few feet at low speed, no faster than 2 km/h (1.2 mph), to a convenient location for repair. These instructions are for emergencies only. Always haul the machine if long distance moving is required.

Shielding must be provided on the towing machine, to protect the operator if the tow line or bar should break.

Do not allow riders on the machine being towed, unless the operator can control the steering and/or braking.

Before towing, make sure the tow line or bar is in good condition and has enough strength for the towing situation involved. Use a towing line or bar with a strength of at least 1.5 times the gross weight of the towing machine, for a disabled machine stuck in mud or when towing on a grade.

Do not use a chain for pulling. A chain link may break causing possible personal injury. Use a wire rope cable with loop or ring ends. Use an observer in a safe position to stop the pulling procedure if cable starts to break or unravel. Stop pulling whenever the pulling machine moves without the towed machine.

Keep the tow line angle to a minimum. Do not exceed a 30° angle from the straight ahead position.

Quick machine movement could overload the tow line or bar and cause it to break. Gradual and smooth machine movement will work better.

Normally, the towing machine should be as large as the disabled machine. Satisfy yourself that the towing machine has enough brake capacity, weight and power, to control both machines for the grade and distance involved.

To provide sufficient control and braking when moving a disabled machine downhill, a larger towing machine or additional machines connected to the rear could be required. This will prevent it from rolling uncontrolled.

The different situation requirements cannot be given, as minimal towing machine capacity is required on smooth level surfaces to maximum on inclines or poor surface conditions.

When short distance towing is necessary, drain the final drives in a clean pan. Remove the covers. Remove the retaining rings from the sun gears. Remove the sun gears.

NOTE: Without the sun gears in place, the vehicle brakes are ineffective. Provide other means to hold or stop the vehicle.

Install the covers. Be sure the O-rings are not damaged. Fill the final drives again with clean oil. The machine can now be towed.

NOTE: Drain the oil and make sure the sun gears and retaining rings are installed again after towing is completed. Fill the final drives with clean oil.

Consult your Caterpillar dealer for additional towing information for a disabled machine.

Product: EXCAVATOR

Model: 213B EXCAVATOR 1EJ

Configuration: 213B EXCAVATOR TRACK TYPE 1EJ00001-UP (MACHINE) POWERED BY 3116 ENGINE

Operation and Maintenance Manual 213B LC TRACK-TYPE EXCAVATOR

Media Number -SEBU6049-00

Publication Date -01/04/1989

Date Updated -11/10/2001

Product Identification and Serial Number Locations

SMCS - 7606

The Product Identification Number (PIN) will be used to identify powered earthmoving equipment that is designed for an operator to ride. The PIN will have the same prefixes and continue in the sequence as the current Serial Numbers.

Caterpillar products such as earthmoving equipment not designed for an operator to ride (scrapers, engines, transmissions, etc.) are identified by Serial Numbers. Also, most major Caterpillar attachments are identified by Serial Numbers.

For quick reference, record the identification numbers in the spaces provided below the photographs.

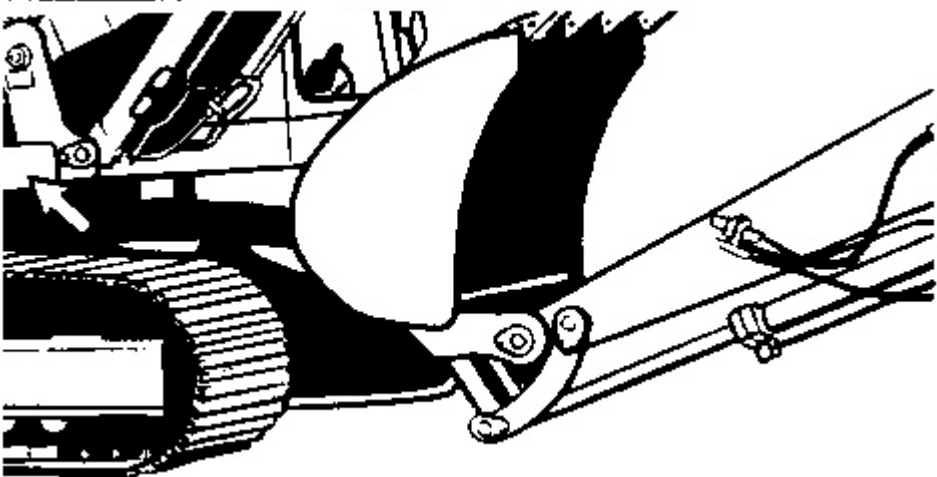

Product Identification Number (PIN) _____



Suggest:

For more complete manuals. Please go to the home page.

<https://www.ebooklibonline.com>

If the above button click is invalid. Please download this document first, and then click the above link to download the complete manual.

Thank you so much for reading

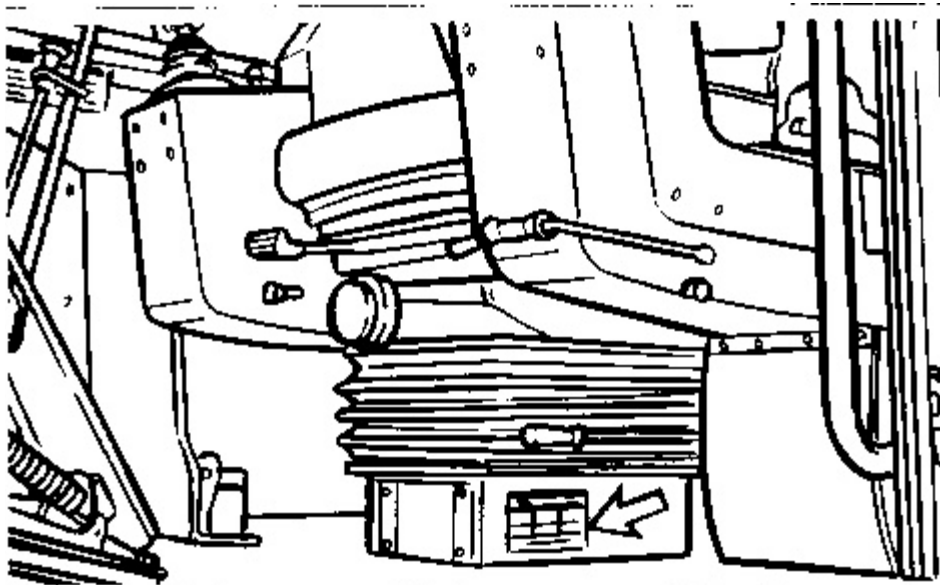

Service Information Number Plate (SIN)

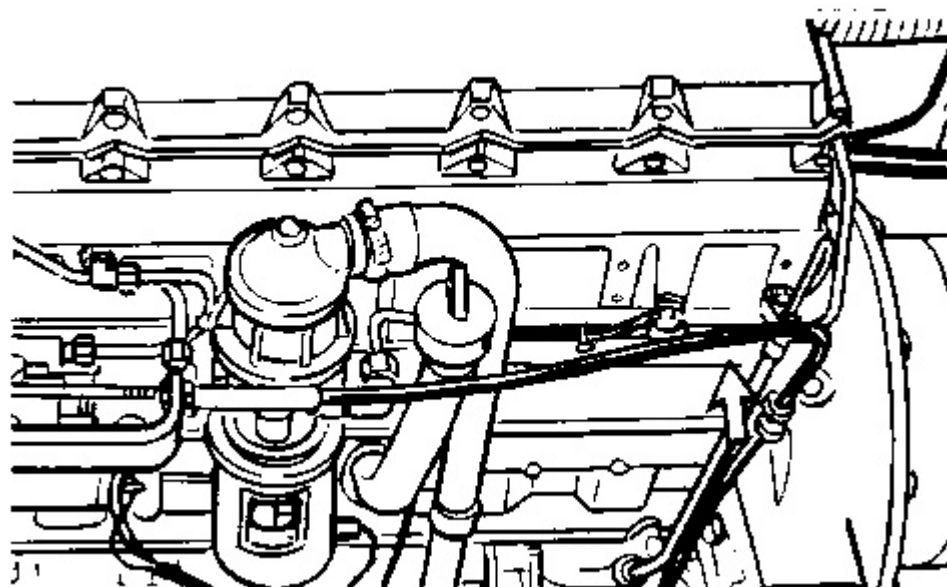

Engine Serial Number Plate _____

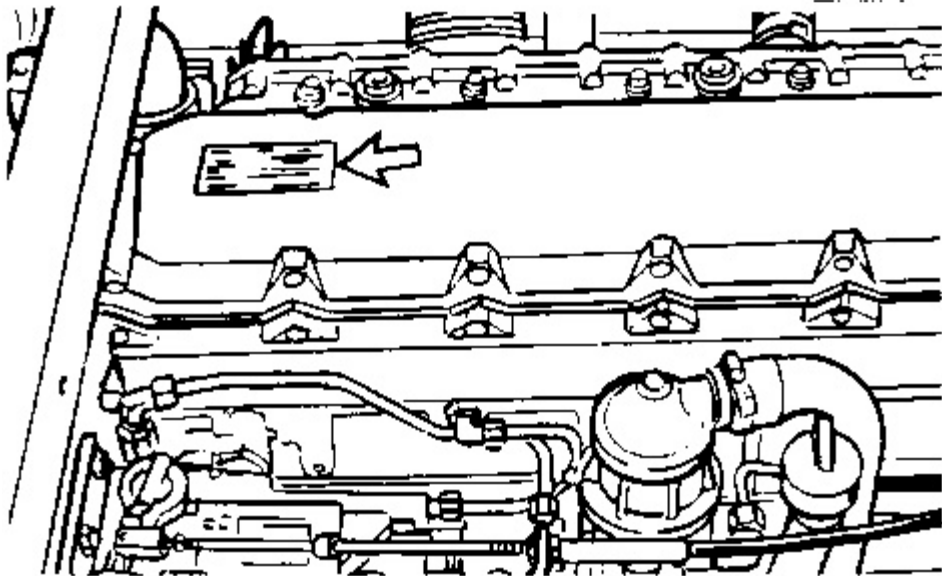

Engine Information Plate

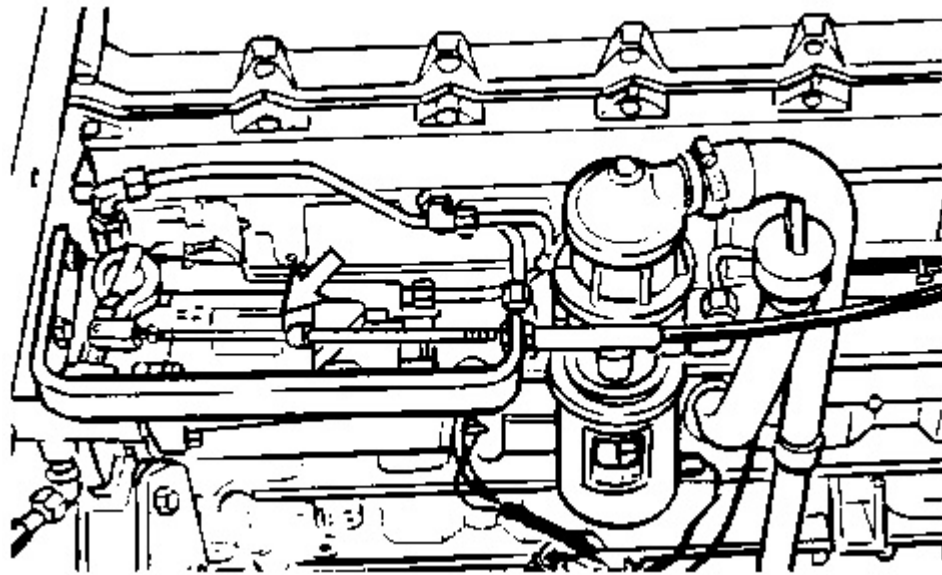

Governor Information Plate

<https://www.ebooklibonline.com>

Hello dear friend!

Thank you very much for reading.

Enter the link into your browser.

The full manual is available for immediate download.

<https://www.ebooklibonline.com>