

Product: TRACK-TYPE TRACTOR

Model: D3G TRACK-TYPE TRACTOR CFF

Configuration: D3G XL & LGP TRACK TYPE TRACTORS CFF00001-UP (MACHINE) POWERED BY 3046 Engine

Disassembly and Assembly D3G, D4G and D5G Hystat Track-Type Tractors Power Train

Media Number -REN5569-03

Publication Date -01/07/2018

Date Updated -31/07/2018

i01600683

Final Drive and Sprocket - Disassemble

SMCS - 4050-015; 4164-015

Disassembly Procedure

Table 1

Required Tools			
Tool	Part Number	Part Description	Qty
A	1P-0510	Driver Gp	1
B	8H-0663	Bearing Puller Gp	1
C	1P-2321	Combination Puller	1
	5P-7311	Bearing Puller	1
D	1P-7461	Leg	1
	1P-0074	Slide Hammer Puller Gp	1
E	138-7575	Link Bracket	3
F	1P-2420	Transmission Repair Stand	1
	8B-7548	Push-Puller Tool Gp	1
	150-1782	Crossblock	1
	8B-7559	Adapter	2
	5F-7369	Puller Leg	2
G	6B-6682	Full Nut	2
	3H-0465	Push-Puller Plate	2
	H	1P-0520	Driver Gp

J	1H-3112	Bearing Cup Puller	1
	1P-0074	Slide Hammer Puller Gp	1
K	1P-2322	Combination Puller	1

Start By:

- a. Remove the final drive. Refer to Disassembly and Assembly, "Final Drive - Remove".

NOTICE

Care must be taken to ensure that fluids are contained during performance of inspection, maintenance, testing, adjusting, and repair of the product. Be prepared to collect the fluid with suitable containers before opening any compartment or disassembling any component containing fluids.

Refer to Special Publication, NENG2500, "Dealer Service Tool Catalog" for tools and supplies suitable to collect and contain fluids on Cat[®] products.

Dispose of all fluids according to local regulations and mandates.

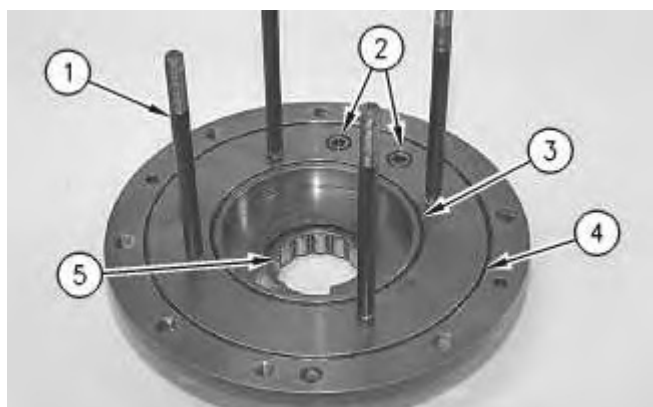

Illustration 1

g00833234

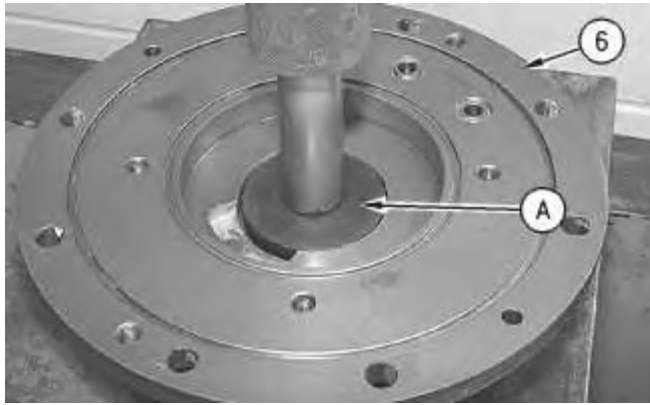

Illustration 2

g00833235

1. Remove studs (1), two O-ring seals (2), O-ring seal (3), and O-ring seal (4) from the cage.
2. Use a suitable press and Tooling (A) in order to remove bearing (5) from cage (6).

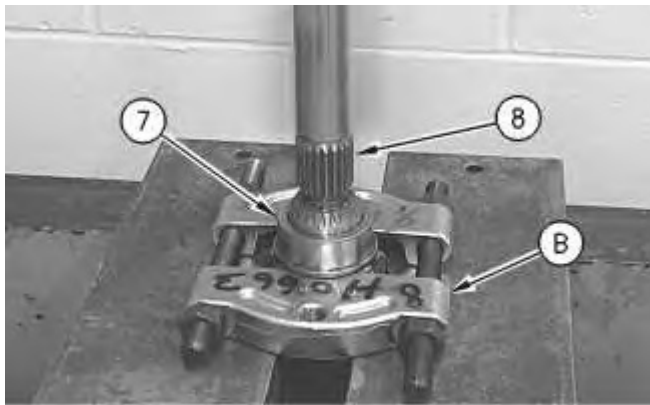

Illustration 3

g00833237

3. Use a press and Tooling (B) in order to remove race (7) from gear (8). Repeat this Step in order to remove the race on the other end of the gear.



Illustration 4

g00833238

4. Remove gear (9) from the case.

<https://www.ebooklibonline.com>

Hello dear friend!

Thank you very much for reading.

Enter the link into your browser.

The full manual is available for immediate download.

<https://www.ebooklibonline.com>

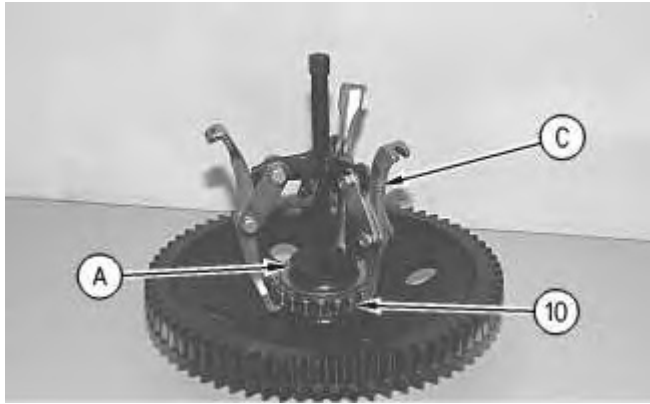

Illustration 5

g00833236

5. Use Tooling (A) and Tooling (C) to remove bearing (10) from the gear.

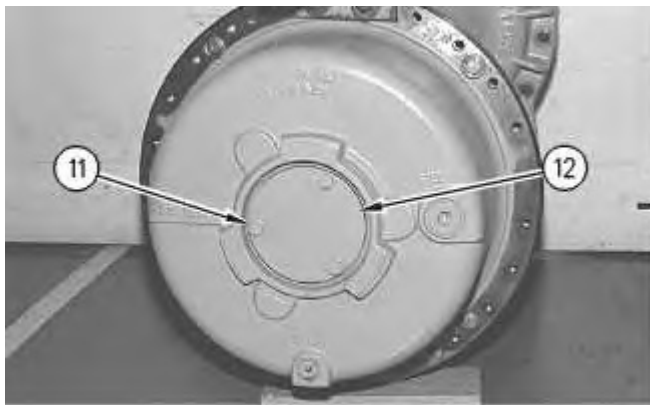

Illustration 6

g00833239

6. Remove bolts (11) and cover (12) from the carrier assembly.

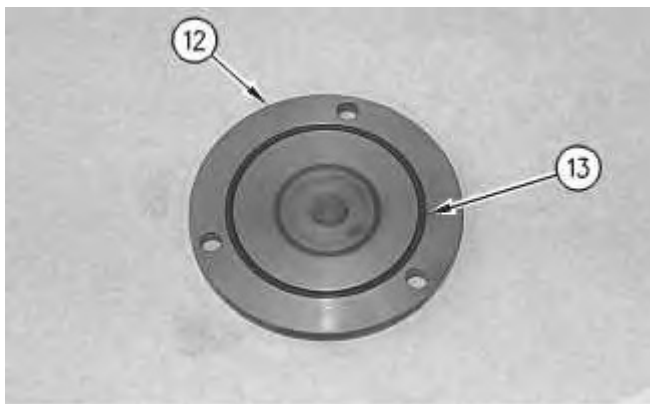

Illustration 7

g00833486

7. Remove O-ring seal (13) from cover (12).

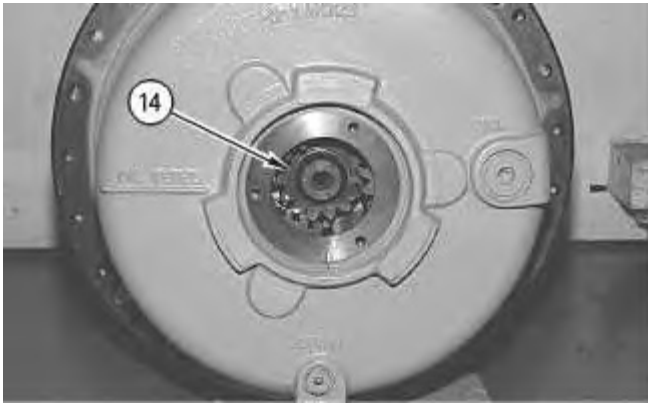

Illustration 8

g00833489

8. Remove shaft (14) by pushing the shaft from the opposite side.

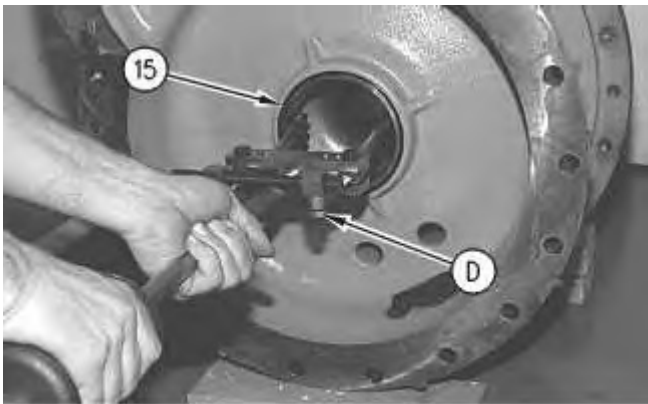

Illustration 9

g00833490

9. Use Tooling (D) in order to remove race (15).

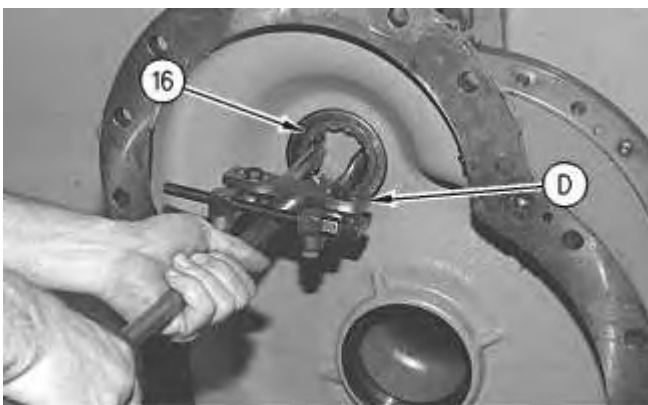

Illustration 10

g00833492

10. Use Tooling (D) in order to remove bearing (16).

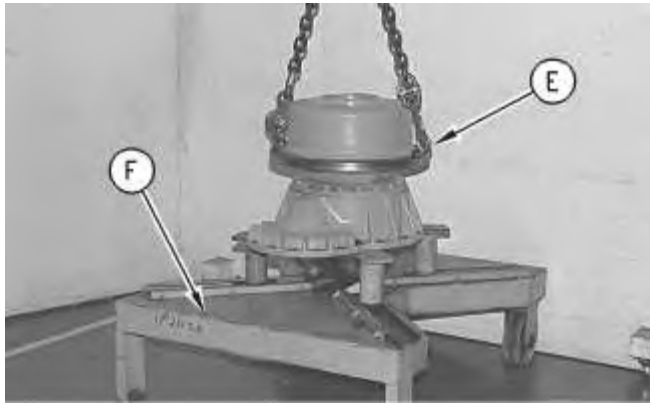

Illustration 11

g00833494

11. Attach Tooling (E) to the carrier assembly. Use chains, Tooling (E), and a suitable lifting device in order to install the final drive assembly on Tooling (F).
12. Remove Tooling (E).

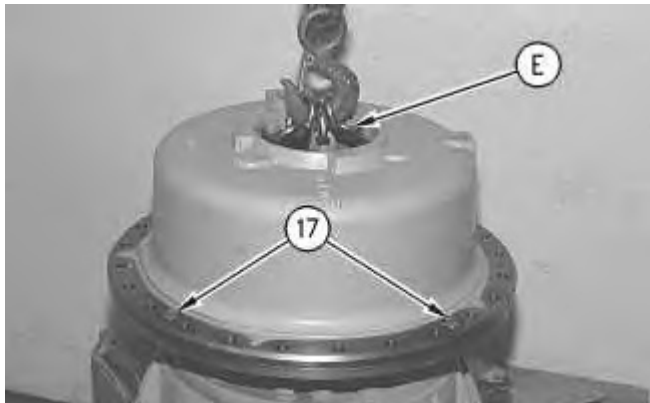

Illustration 12

g00833495

13. Attach Tooling (E) to the top of the carrier assembly with three M10 by 35 mm bolts and washers. Use a chain and a suitable lifting device in order to support the carrier assembly. Remove bolts (17).



Illustration 13

g00833496

14. Install two M12 by 175 mm forcing bolts and remove carrier assembly (18). The weight of the carrier assembly is approximately 75 kg (165 lb).



Illustration 14

g00833497

15. Remove bolts (19).

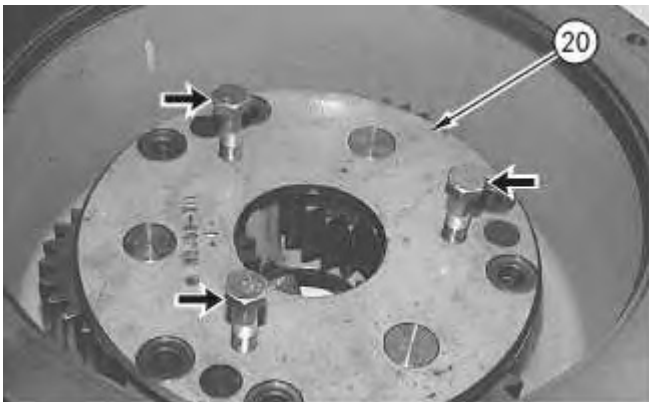

Illustration 15

g00833536

16. Install three M16 by 60 mm forcing bolts and remove plate (20).

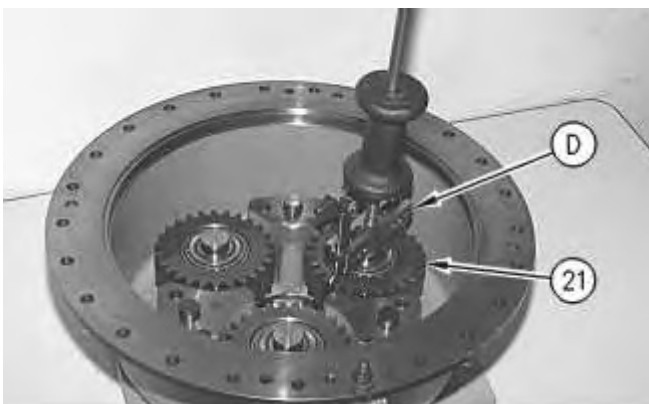

Illustration 16

g00833537

17. Use Tooling (D) and remove gear (21), the shaft, and the bearings.

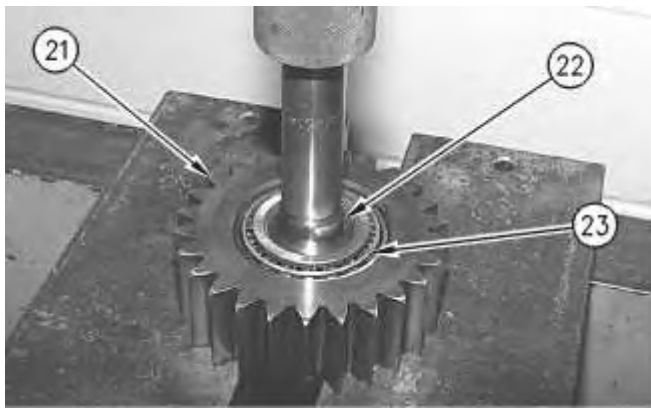

Illustration 17

g00833538

18. Use a suitable press in order to remove shaft (22) from bearing (23), and gear (21).
19. Place the shaft and the bearing in a position in order to remove the remaining bearing on the other end of the shaft.

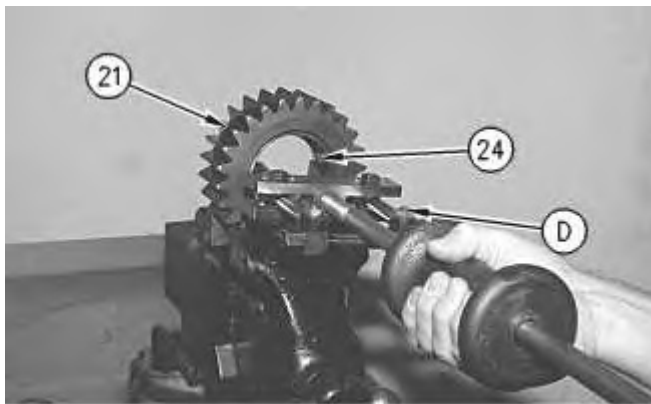

Illustration 18

g00833540

20. Use Tooling (D) in order to remove cup (24) from gear (21). Repeat this Step for the cup on the other side of the gear.
21. Repeat Steps 17 through 20 for the remaining two gears.

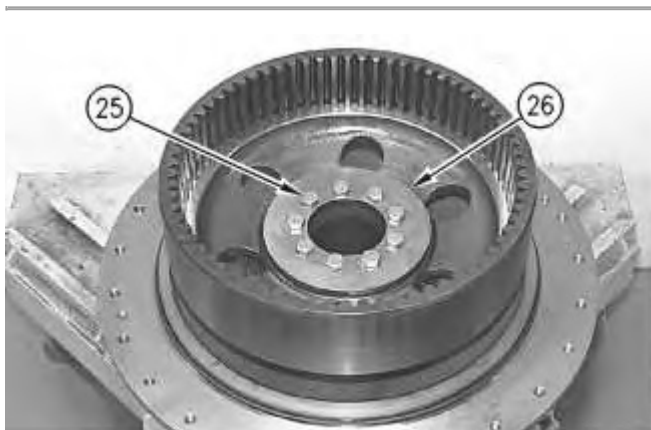

Illustration 19

g00833541

22. Remove bolts (25) and retainer (26) from the hub.

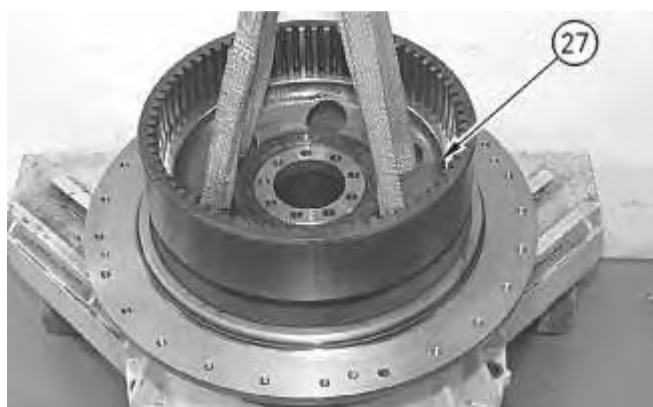

Illustration 20

23. Use straps and a suitable lifting device in order to remove hub (27) and the ring gear. The weight of the hub and ring gear is approximately 27 kg (60 lb).



Illustration 21

24. Remove retainer (28). Remove hub (27) from ring gear (29).

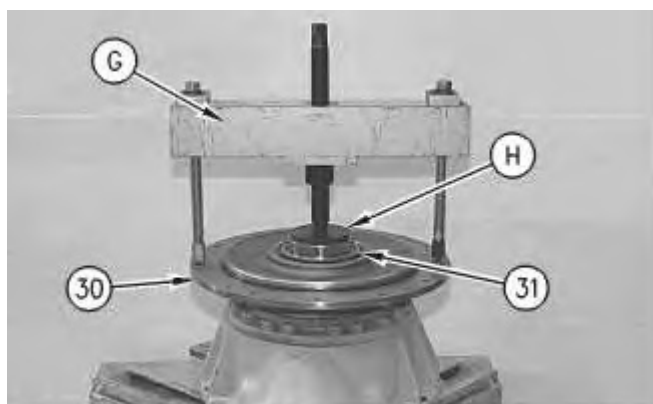

Illustration 22

25. Install Tooling (G) and Tooling (H), as shown. Pull hub (30) and bearing (31) away from the spindle.

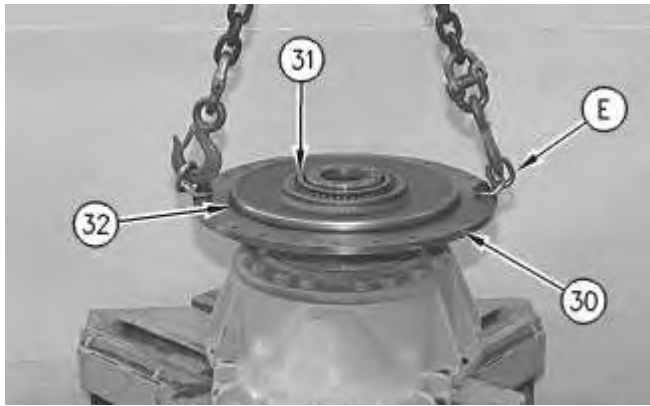

Illustration 23

g00833560

26. Remove bearing (31) and O-ring seal (32). Install Tooling (E). Use chains, Tooling (E), and a suitable lifting device in order to remove hub (30). The weight of the hub is approximately 64 kg (140 lb).
27. Remove Tooling (E).

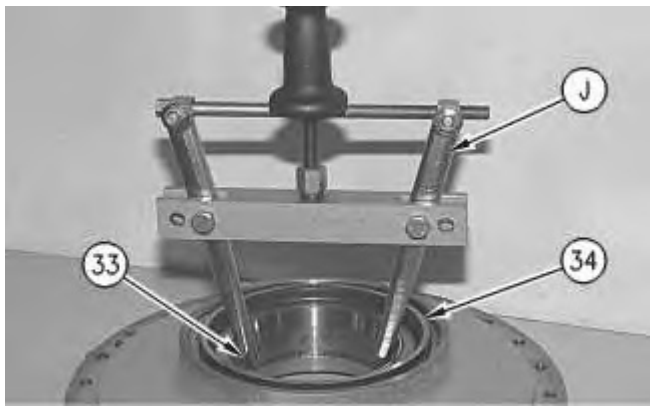

Illustration 24

g00833561

28. Use Tooling (J) in order to remove cup (33).
29. Remove Duo-Cone Seal kit (34).
30. Repeat Steps 27 and 29 for the opposite side of the hub.
-



Illustration 25

g00833562

31. Remove bolts (35).

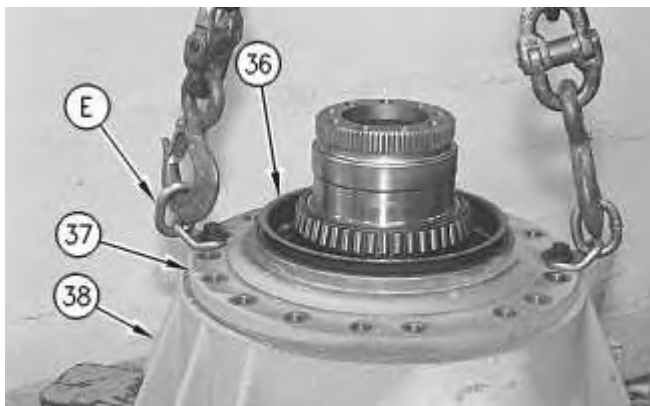

Illustration 26

g00833563

32. Remove Duo-Cone Seal kit (36).
33. Install Tooling (E) with two M12 by 40 mm bolts. Use chains, Tooling (E), and a suitable lifting device in order to remove spindle (37) from case (38). The weight of the spindle is approximately 43 kg (95 lb).
34. Remove Tooling (E).

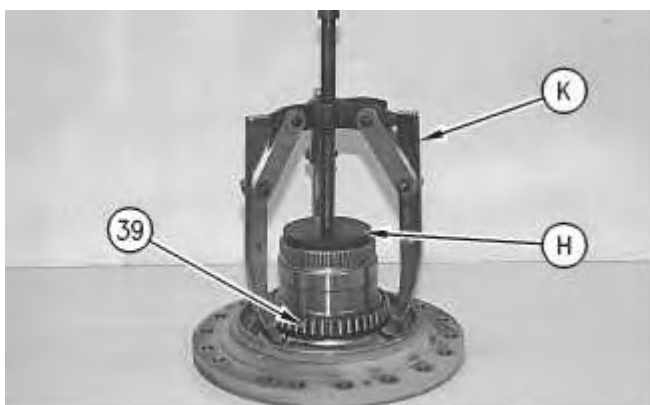

Illustration 27

g00833565

35. Use Tooling (H) and Tooling (K) in order to remove bearing cone (39).

Note: The removal procedure may cause damage to the bearing cone.



Illustration 28

g00833635

36. Place the spindle in this position, as shown. Remove O-ring seal (40).

Product: TRACK-TYPE TRACTOR

Model: D3G TRACK-TYPE TRACTOR CFF

Configuration: D3G XL & LGP TRACK TYPE TRACTORS CFF00001-UP (MACHINE) POWERED BY 3046 Engine

Disassembly and Assembly D3G, D4G and D5G Hystat Track-Type Tractors Power Train

Media Number -REN5569-03

Publication Date -01/07/2018

Date Updated -31/07/2018

i03093946

Final Drive and Sprocket - Assemble

SMCS - 4050-016; 4164-016

Assembly Procedure

Table 1

Required Tools			
Tool	Part Number	Part Description	Qty
A	1U-6437	Duo-Cone Seal Installer As	1
B	138-7575	Link Bracket	3
C	289-2961	Bearing Driver	1
D	1P-0510	Driver Gp	1
E	1P-2420	Transmission Repair Stand	1
G	169-0503	Installation Kit	1

Note: Check the O-ring seals for wear or for damage. Replace the O-ring seals, if necessary.



Illustration 1

g00833635

1. Install O-ring seal (40) on the spindle.

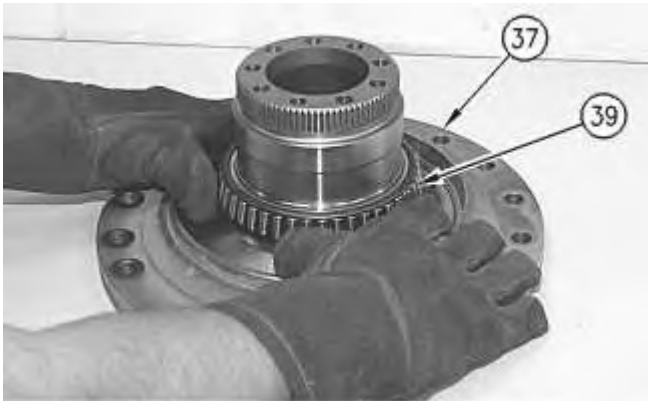

Illustration 2

g00833704

2. Raise the temperature of bearing (39). Install the bearing on spindle (37).

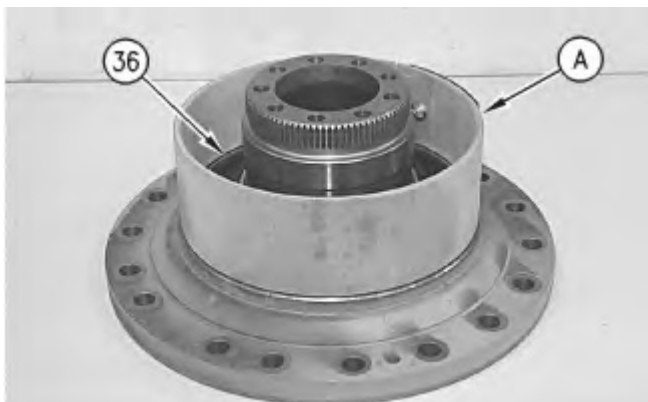

Illustration 3

g00833705

3. Install Duo-Cone Seal Kit (36) on the spindle with Tooling (A) and Tooling (G). Refer to Disassembly and Assembly, "Duo-Cone Conventional Seals - Install".



4. Attach Tooling (B) to spindle (37). Use chains, Tooling (B), and a suitable lifting device in order to install the spindle on case (38). Remove Tooling (B).



Illustration 5

5. Install bolts (35).



Illustration 6

6. Lower the temperature of cup (33) and install the cup in the hub. Repeat this Step for the other side of the hub.



7. Use Tooling (A) in order to install Duo-Cone Seal Kit (34). Refer to Disassembly and Assembly, "Duo-Cone Conventional Seals - Install".



Illustration 8

8. Place hub (27) in ring gear (29). Install retainer (28).

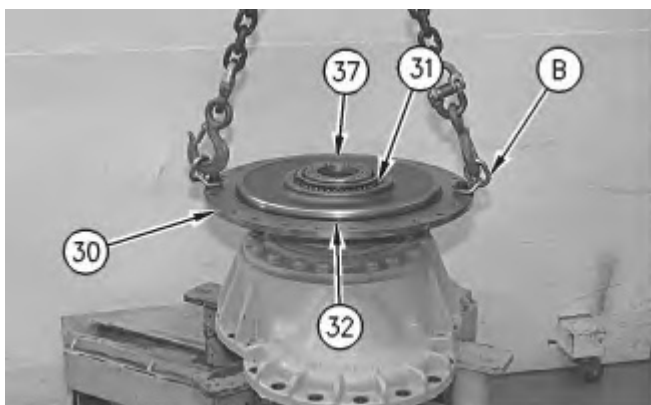

Illustration 9

9. Install Tooling (B), chains and a suitable lifting device in order to place hub (30) on spindle (37). The weight of the hub is approximately 64 kg (140 lb). Remove Tooling (B).
10. Install O-ring seal (32).
11. Raise the temperature of bearing (31). Install the bearing on the spindle.

Note: Proceed to Step 12 before the bearing cools.

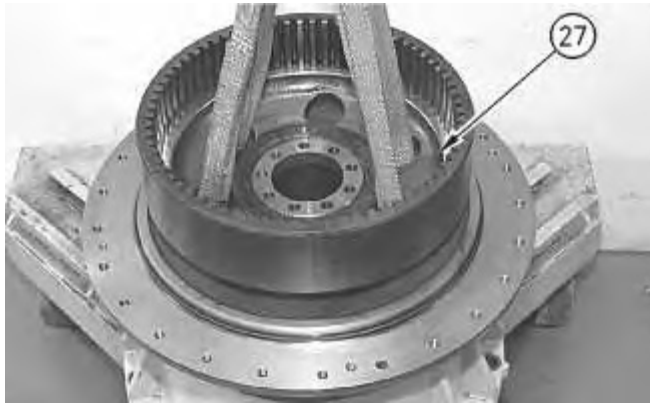

Illustration 10

g00833543

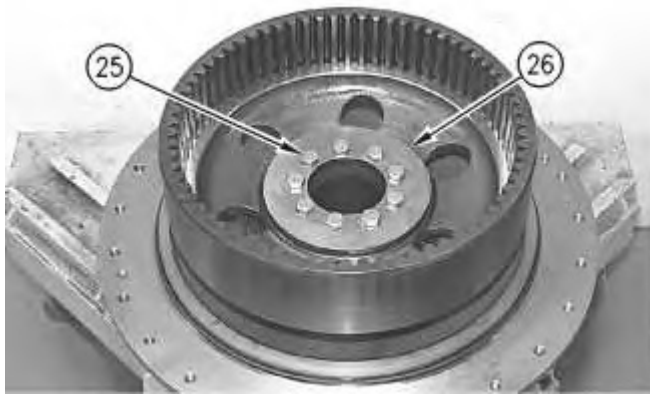

Illustration 11

g00833542

12. Use straps and a suitable lifting device in order to install hub (27) on the spindle.
13. Install retainer (26) and bolts (25). Tighten the bolts to a torque of $120 \pm 20 \text{ N}\cdot\text{m}$ ($89 \pm 15 \text{ lb ft}$).

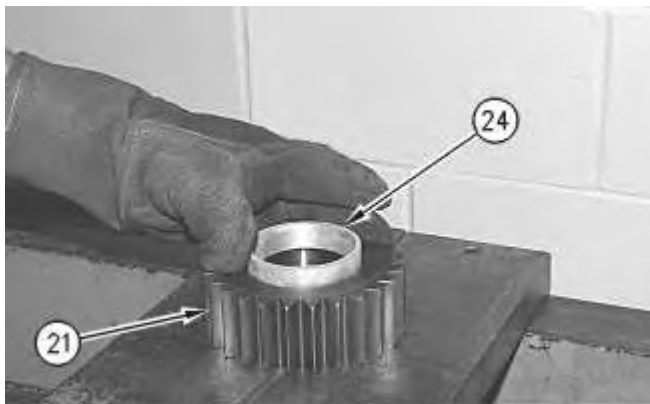

Illustration 12

g00833817

14. Lower the temperature of cup (24). Install the cup in gear (21). Repeat this Step for the cup on the other side of the gear.



Suggest:

For more complete manuals. Please go to the home page.

<https://www.ebooklibonline.com>

If the above button click is invalid. Please download this document first, and then click the above link to download the complete manual.

Thank you so much for reading

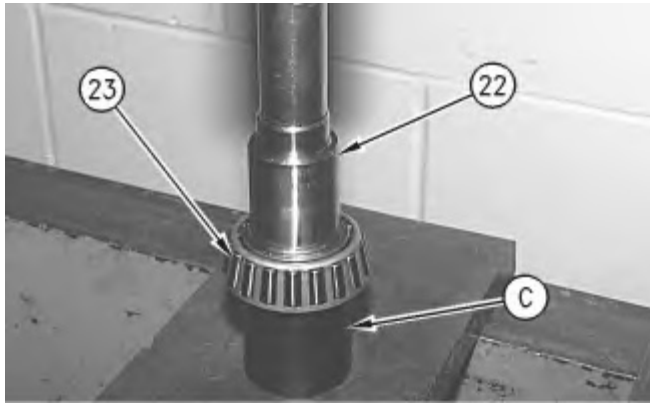

Illustration 13

g00833820

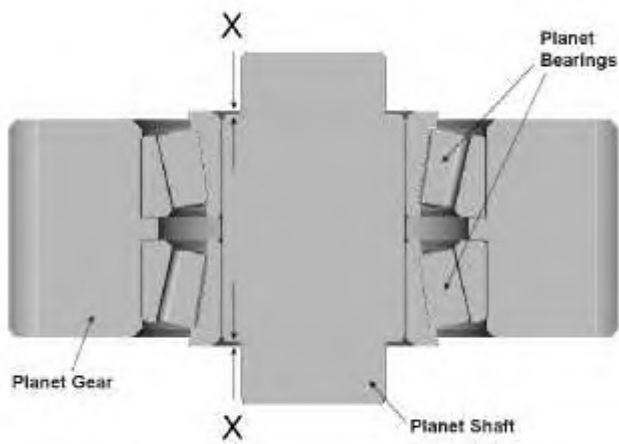

Illustration 14

g01237621

Note: Tooling (C) must be used in order to maintain Dimension (X). Dimension (X) is 1.0 mm (0.04 inch). Bearing cone (23) must extend past the shoulder of shaft (22) by the amount of Dimension (X) in order to create the correct bearing preload.

15. Raise the temperature of bearing cone (23) and place the bearing on Tooling (C). Use a suitable press in order to install shaft (22) until the shaft and bearing cone (23) are seated on Tooling (C).
-

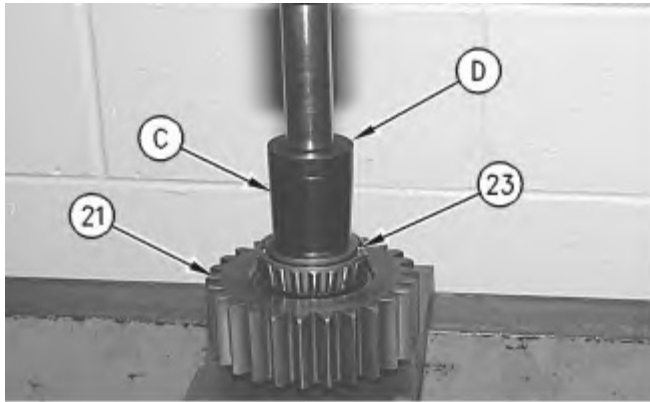

Illustration 15

g00833821

Note: Tooling (C) must be used in order to maintain Dimension (X). Dimension (X) is 1.0 mm (0.04 inch). Bearing cone (23) must extend past the shoulder of shaft (22) by the amount of Dimension (X) in order to create the correct bearing preload. Refer to Illustration 14.

16. Install gear (21) on shaft (22). Raise the temperature of the remaining bearing cone (23). Place bearing cone (23) in position on gear (21). Use a suitable press, Tooling (C), and Tooling (D) in order to install bearing cone (23) in gear (21).

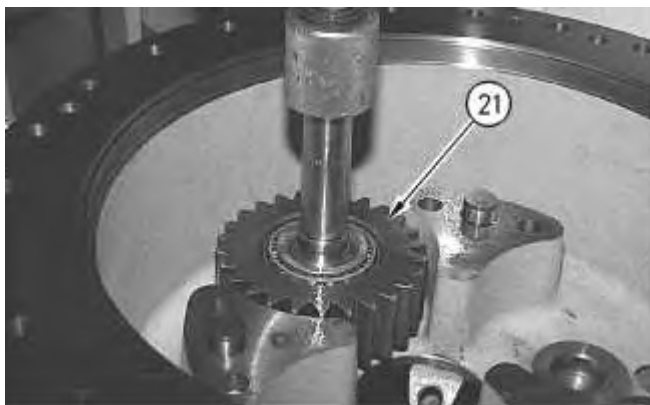
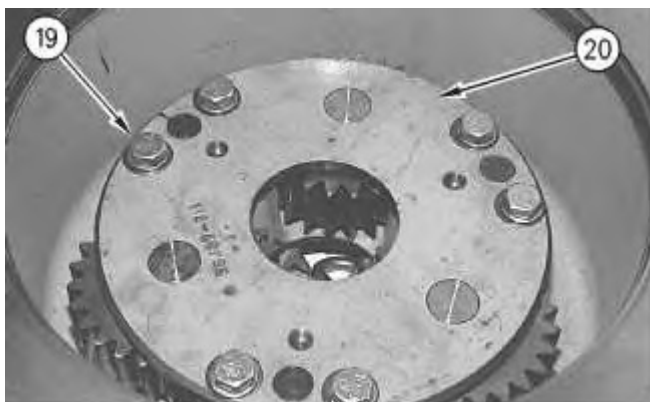

Illustration 16

g00834101

17. Use a suitable press in order to install gear (21) and the other components in the case. Repeat Steps 13 through 17 for the remaining gears and the other components.



<https://www.ebooklibonline.com>

Hello dear friend!

Thank you very much for reading.

Enter the link into your browser.

The full manual is available for immediate download.

<https://www.ebooklibonline.com>