

Product: VIBRATORY COMPACTOR

Model: CB-434B VIBRATORY COMPACTOR 7YN

Configuration: CB-434B Vibratory Compactor 7YN00001-UP (MACHINE) POWERED BY 3054 Engine

Disassembly and Assembly 3054 Engine for Caterpillar Built Machines

Media Number -SEN6241-13

Publication Date -01/08/2008

Date Updated -04/08/2008

i01598347

Exhaust Manifold - Remove and Install - Type 2 Engines and 7BJ Engines

SMCS - 1059-010

Removal Procedure

Start By:

- A. Remove the turbocharger. Refer to Disassembly and Assembly, "Turbocharger - Remove".
- B. Remove the air inlet manifold. Refer to Disassembly and Assembly, "Air Inlet Manifold - Remove and Install".

Note: For a complete description of Type 1 and Type 2 Engines, refer to the Disassembly and Assembly, "Engine Design" topic.

NOTICE

Keep all parts clean from contaminants.

Contaminants may cause rapid wear and shortened component life.

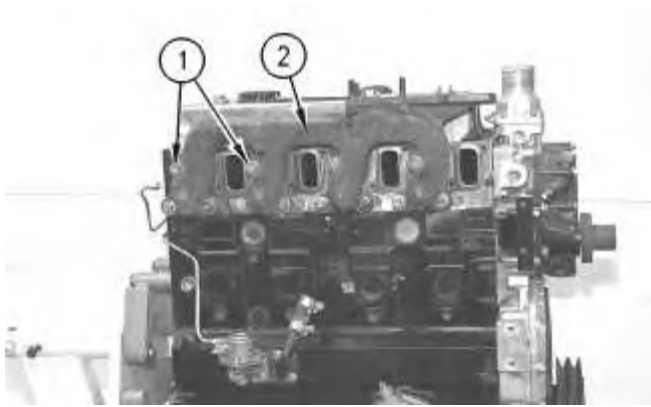

Illustration 1

g00557287

Typical example

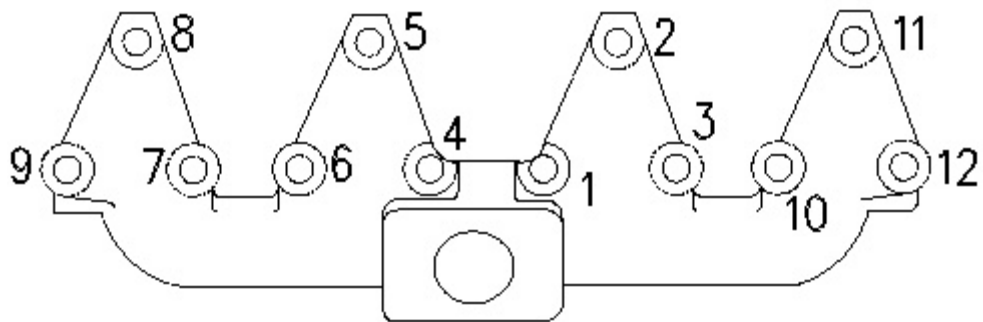

Illustration 2

g00557337

1. Remove exhaust manifold nuts or bolts (1) in reverse order of the numbered sequence.
 2. Remove exhaust manifold (2) from the engine.
-

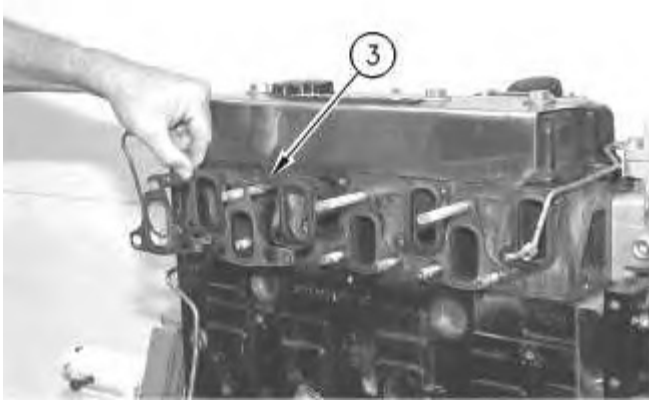

Illustration 3

g00557351

Typical example

3. Remove exhaust manifold gaskets (3) from the engine.
4. Remove old sealant from stud threads.

Installation Procedure

NOTICE

Keep all parts clean from contaminants.

Contaminants may cause rapid wear and shortened component life.

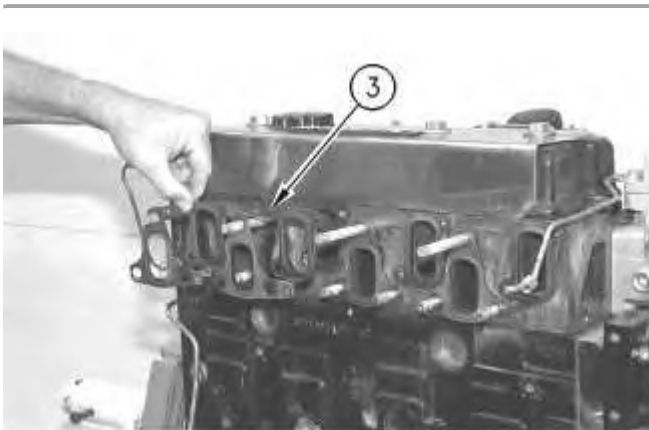

Illustration 4

g00557351

Typical example

<https://www.ebooklibonline.com>

Hello dear friend!

Thank you very much for reading.

Enter the link into your browser.

The full manual is available for immediate download.

<https://www.ebooklibonline.com>

1. Inspect the condition of the gaskets. If the gaskets are damaged, use new parts for replacement. Install exhaust manifold gaskets (3) on the cylinder head. Apply **4C-9507 Retaining Compound** to the stud threads.

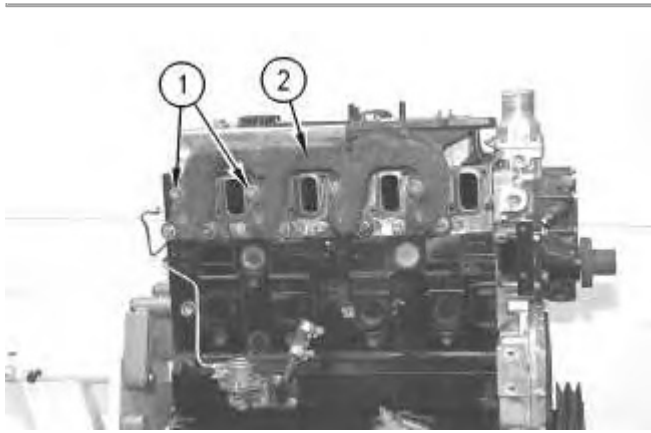

Illustration 5

g00557287

Typical example

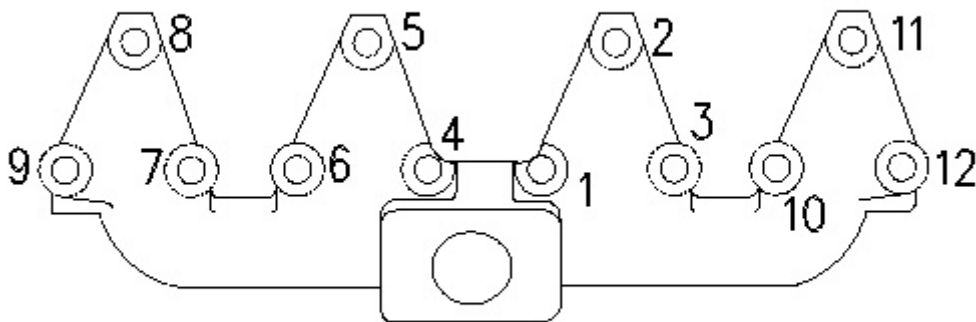

Illustration 6

g00557337

NOTICE

Damage to the exhaust manifold can occur if the exhaust manifold is not aligned and tightened correctly.

2. Install exhaust manifold (2) on the cylinder head.

Note: Some of the exhaust manifolds have large clearance holes for the bolts. If a new exhaust manifold is installed ensure that the **148-7132** Ferrule mountings that are supplied with the exhaust manifold are installed.

3. Install exhaust manifold nuts or bolts (1). Tighten the exhaust manifold nuts or bolts in the numerical sequence to a torque of 44 N·m (33 lb ft).

End By:

- a. Install the air inlet manifold. Refer to Disassembly and Assembly, "Air Inlet Manifold - Remove and Install".
 - b. Install the turbocharger. Refer to Disassembly and Assembly, "Turbocharger - Install".
-

Product: VIBRATORY COMPACTOR

Model: CB-434B VIBRATORY COMPACTOR 7YN

Configuration: CB-434B Vibratory Compactor 7YN00001-UP (MACHINE) POWERED BY 3054 Engine

Disassembly and Assembly 3054 Engine for Caterpillar Built Machines

Media Number -SEN6241-13

Publication Date -01/08/2008

Date Updated -04/08/2008

i01068659

Exhaust Manifold - Remove and Install - Type 1 Engines and 9RM Engines

SMCS - 1059-010

Removal Procedure

Start By:

- A. Remove the turbocharger. Refer to Disassembly and Assembly, "Turbocharger - Remove".

Note: For a complete description of Type 1 and Type 2 Engines, refer to the Disassembly and Assembly, "Engine Design" topic.

NOTICE

Keep all parts clean from contaminants.

Contaminants may cause rapid wear and shortened component life.



Illustration 1

g00542541

Typical example

1. Remove exhaust manifold nuts (1) .
2. Remove exhaust manifold (2) and the gasket.

Installation Procedure

NOTICE

Keep all parts clean from contaminants.

Contaminants may cause rapid wear and shortened component life.



Illustration 2

g00542541

Typical example

1. Inspect the condition of the gasket. Replace the gasket, if necessary.
2. Install the gasket and exhaust manifold (2) .
3. Install exhaust manifold nuts (1). Tighten the plated nuts to a torque of 44 N·m (32 lb ft). Tighten the nuts that are not plated to a torque of 50 N·m (37 lb ft).

End By: Install the turbocharger. Refer to Disassembly and Assembly, "Turbocharger - Install".

Product: VIBRATORY COMPACTOR

Model: CB-434B VIBRATORY COMPACTOR 7YN

Configuration: CB-434B Vibratory Compactor 7YN00001-UP (MACHINE) POWERED BY 3054 Engine

Disassembly and Assembly 3054 Engine for Caterpillar Built Machines

Media Number -SEN6241-13

Publication Date -01/08/2008

Date Updated -04/08/2008

i02870246

Inlet Manifold - Remove - Type 2 Engines and 7BJ Engines

SMCS - 1058-011

Removal Procedure

Note: For a complete description of Type 1 and Type 2 engines, refer to Disassembly and Assembly, "Engine Design".

NOTICE

Keep all parts clean from contaminants.

Contaminants may cause rapid wear and shortened component life.

NOTICE

Care must be taken to ensure that fluids are contained during performance of inspection, maintenance, testing, adjusting and repair of the product. Be prepared to collect the fluid with suitable containers before opening any compartment or disassembling any component containing fluids.

Refer to Special Publication, NENG2500, "Caterpillar Dealer Service Tool Catalog" for tools and supplies suitable to collect and contain fluids on Caterpillar products.

Dispose of all fluids according to local regulations and mandates.

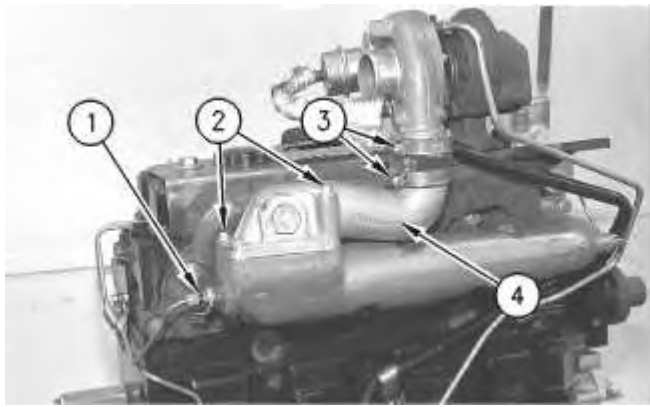

Illustration 1

g00557838

Typical example

1. Disconnect tube (1) from the air inlet heater.
2. Loosen hose clamps (3) and slide the hose toward the turbocharger.
3. Remove four bolts (2) and remove elbow (4) from the air inlet manifold.

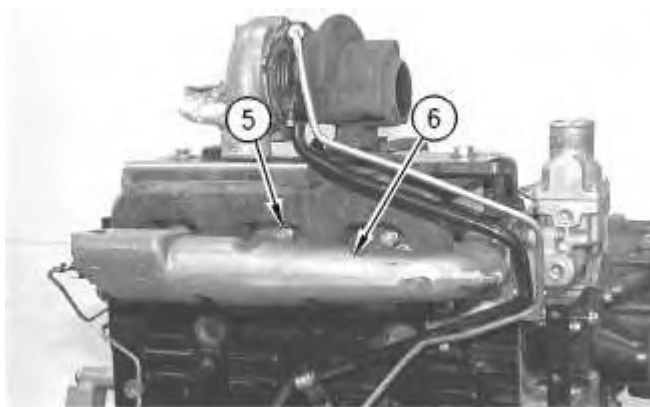

Illustration 2

g00558245

Typical example

4. Remove bolts (5) that fasten air inlet manifold (6) to the engine.
 5. Remove air inlet manifold (6) .
-

Product: VIBRATORY COMPACTOR

Model: CB-434B VIBRATORY COMPACTOR 7YN

Configuration: CB-434B Vibratory Compactor 7YN00001-UP (MACHINE) POWERED BY 3054 Engine

Disassembly and Assembly 3054 Engine for Caterpillar Built Machines

Media Number -SEN6241-13

Publication Date -01/08/2008

Date Updated -04/08/2008

i02870245

Inlet Manifold - Remove - Type 1 Engines and 9RM Engines

SMCS - 1058-011

Removal Procedure

Note: For a complete description of Type 1 and Type 2 engines, refer to Disassembly and Assembly, "Engine Design".

NOTICE

Keep all parts clean from contaminants.

Contaminants may cause rapid wear and shortened component life.

NOTICE

Care must be taken to ensure that fluids are contained during performance of inspection, maintenance, testing, adjusting and repair of the product. Be prepared to collect the fluid with suitable containers before opening any compartment or disassembling any component containing fluids.

Refer to Special Publication, NENG2500, "Caterpillar Dealer Service Tool Catalog" for tools and supplies suitable to collect and contain fluids on Caterpillar products.

Dispose of all fluids according to local regulations and mandates.

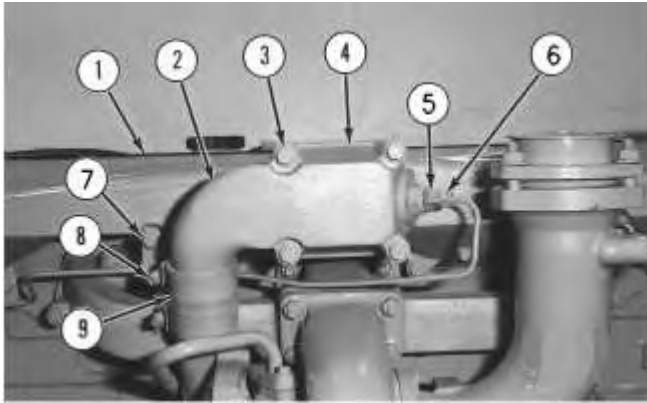

Illustration 1

g00545513

Typical example

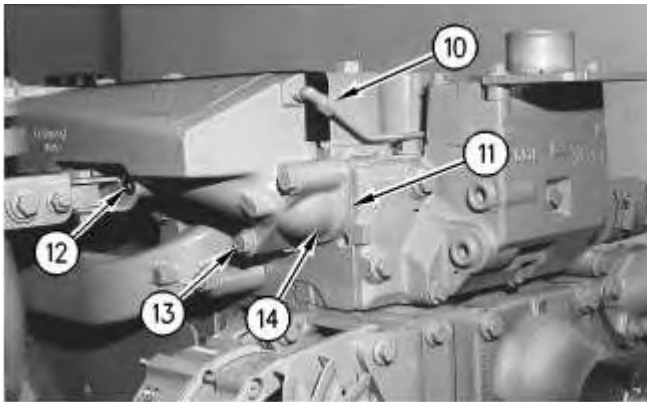

Illustration 2

g00545514

Typical example

1. Disconnect electrical connector (5) for the air inlet heater.
2. Disconnect fuel line (6) to the air inlet heater.
3. Remove two bolts (7) that hold the bracket for fuel line (6) in position.
4. Loosen two hose clamps (8) and slide hose (9) toward the turbocharger.
5. Remove four bolts (3) in order to remove elbow (2) and gasket (4) .
6. Disconnect boost pressure hose (10) .
7. Remove bolts (12) that hold the turbocharger support to air inlet manifold (14) .
8. Remove bolts (13) that hold air inlet manifold (14) to the cylinder head.

9. Remove air inlet manifold (14) and gaskets (11) .

10. Remove seal (1) .



Suggest:

For more complete manuals. Please go to the home page.

<https://www.ebooklibonline.com>

If the above button click is invalid. Please download this document first, and then click the above link to download the complete manual.

Thank you so much for reading

Product: VIBRATORY COMPACTOR

Model: CB-434B VIBRATORY COMPACTOR 7YN

Configuration: CB-434B Vibratory Compactor 7YN00001-UP (MACHINE) POWERED BY 3054 Engine

Disassembly and Assembly 3054 Engine for Caterpillar Built Machines

Media Number -SEN6241-13

Publication Date -01/08/2008

Date Updated -04/08/2008

i02870254

Inlet Manifold - Install - Type 1 Engines and 9RM Engines

SMCS - 1058-012

Installation Procedure

Note: For a complete description of Type 1 and Type 2 engines, refer to Disassembly and Assembly, "Engine Design".

NOTICE

Keep all parts clean from contaminants.

Contaminants may cause rapid wear and shortened component life.

1. Inspect the gaskets for wear or damage. If the gaskets are worn or damaged, use new parts for replacement.

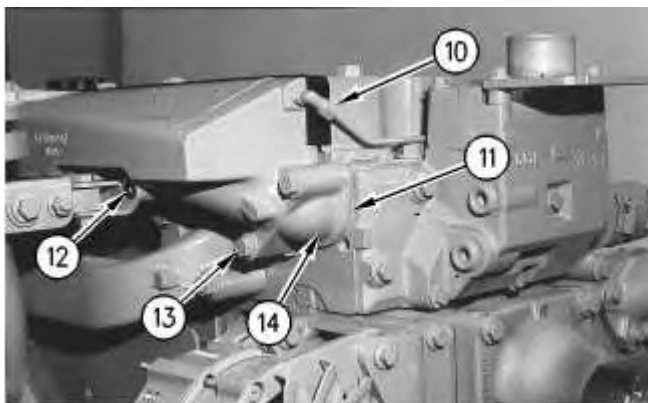

Typical example

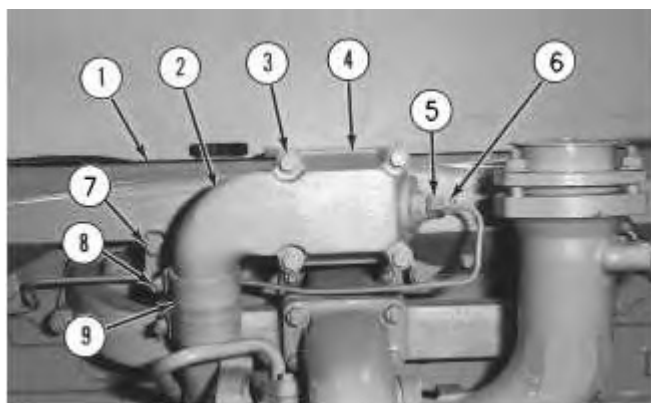

Illustration 2

Typical example

2. Install seal (1) on the engine.
3. Position gaskets (11) and air inlet manifold (14) on the engine.

Note: Ensure that the front gaskets and the rear gaskets are installed with the notch at the top left side. The center gasket can be installed in either direction.

4. Install bolts (13) .
 5. Position the turbocharger support on air inlet manifold (14) and install bolts (12) .
 6. Connect boost pressure hose (10) .
 7. Install gasket (4) and elbow (2) with four bolts (3) .
 8. Slide hose (9) in position and tighten hose clamps (8) .
 9. Place the bracket for fuel line (6) in position and install two bolts (7) .
 10. Connect fuel line (6) to the air inlet heater.
 11. Connect electrical connector (5) for the air inlet heater.
-

<https://www.ebooklibonline.com>

Hello dear friend!

Thank you very much for reading.

Enter the link into your browser.

The full manual is available for immediate download.

<https://www.ebooklibonline.com>