

Product: VIBRATORY COMPACTOR

Model: CB-14 VIBRATORY COMPACTOR DTT

Configuration: CB14 Vibratory Utility Compactor DTT00001-UP (MACHINE) POWERED BY C1.1 Engine

Disassembly and Assembly C1.1, C1.5 and C2.2 Engines for Caterpillar Built Machines

Media Number -KENR8103-03

Publication Date -01/02/2015

Date Updated -09/06/2016

i02236295

Engine Oil Pump - Remove

SMCS - 1304-011

Removal Procedure

Start By:

- a. Remove the engine oil pan. Refer to Disassembly and Assembly, "Engine Oil Pan - Remove and Install".
- b. Remove the front housing. Refer to Disassembly and Assembly, "Housing (Front) - Remove".

NOTICE

Keep all parts clean from contaminants.

Contaminants may cause rapid wear and shortened component life.

NOTICE

**If the front housing is not installed, do not turn the crankshaft.
Damage to the engine may occur.**

NOTICE

Care must be taken to ensure that fluids are contained during performance of inspection, maintenance, testing, adjusting, and repair of the product. Be prepared to collect the fluid with suitable containers before opening any compartment or disassembling any component containing fluids.

Refer to Special Publication, NENG2500, "Dealer Service Tool Catalog" for tools and supplies suitable to collect and contain fluids on Cat products.

Dispose of all fluids according to local regulations and mandates.

Engine Oil Pump

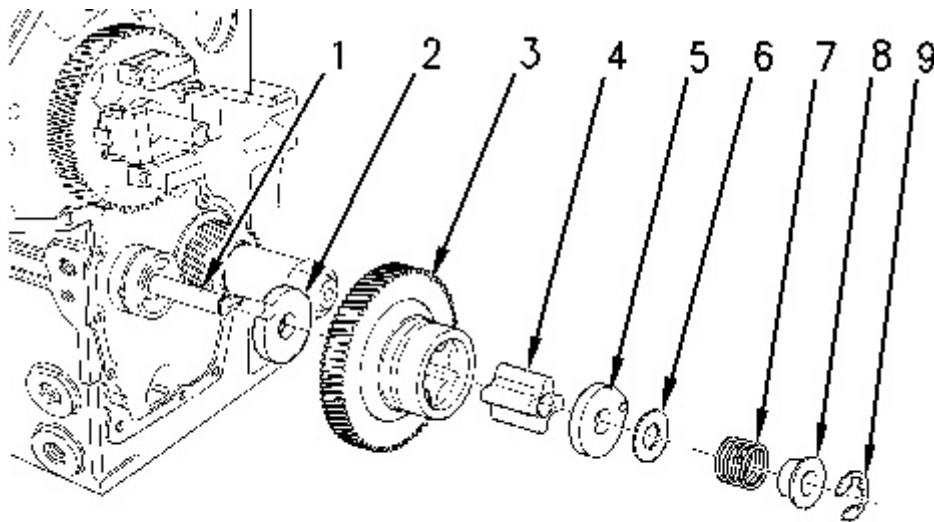

Illustration 1

g00825411

WARNING

Personal injury can result from being struck by parts propelled by a released spring force.

Make sure to wear all necessary protective equipment.

Follow the recommended procedure and use all recommended tooling to release the spring force.

1. Remove the C-clip (9) that retains the idler gear (3) on the idler hub (1).

2. Remove the following items from the idler hub (1):

- Collar (8)
- Spring (7)
- Shim (6)
- Oil pump cover (5)
- Inner rotor (4)

3. Remove the idler gear (3) from the idler hub (1).

4. Remove the thrust washer (2) from the idler hub (1).

5. Inspect all the components for wear or damage. If any components are worn or damaged, use new parts for replacement.

Note: Refer to Specifications, "Engine Oil Pump" for more information.

6. If the engine oil pump has excessive buildup of sludge, inspect the oil strainer. The oil strainer can be removed by using the following procedure:

- a. Remove the engine oil pan. Refer to Disassembly and Assembly, "Engine Oil Pan - Remove and Install".

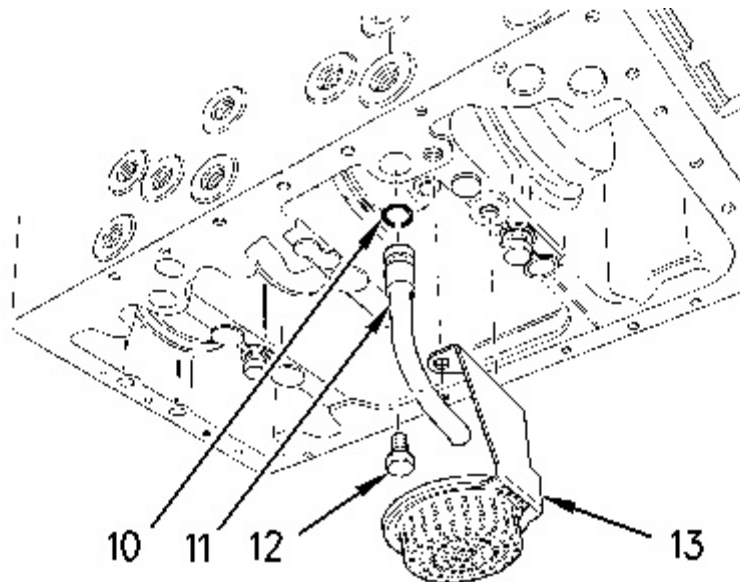

Illustration 2

g00825406

b. Remove the setscrews (12) and the oil strainer (13) from the cylinder block. Inspect the oil strainer for damage. If the oil strainer is damaged, use a new part for replacement.

c. Remove the oil tube (11) from the cylinder block.

d. Remove the O-ring (10) from the oil tube. Discard the used O-ring.

<https://www.ebooklibonline.com>

Hello dear friend!

Thank you very much for reading.

Enter the link into your browser.

The full manual is available for immediate download.

<https://www.ebooklibonline.com>

Idler Hub

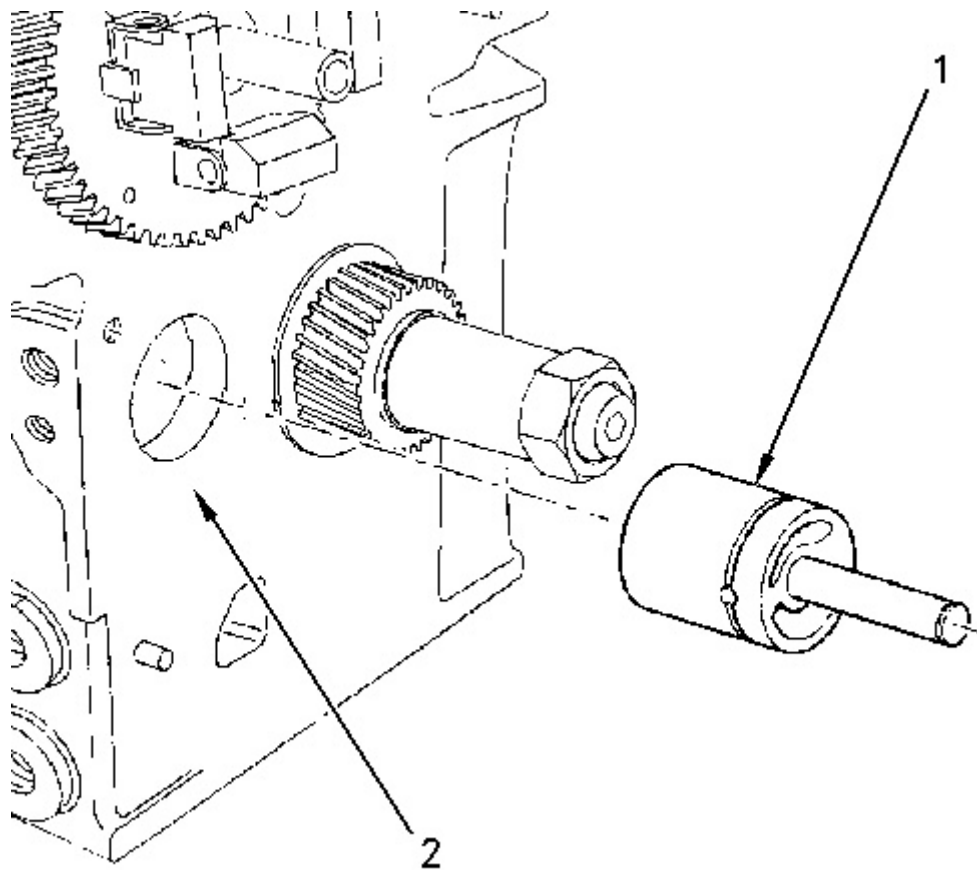

Illustration 3
Typical example

g00831103

1. Remove the crankshaft. Refer to Disassembly and Assembly, "Crankshaft - Remove".
 2. Use a hammer and use a suitable drift to remove idler hub (1) from the cylinder block (2). Align the drift to the rear face of the hub and drive the hub from the inside of the cylinder block outward.
-

Product: VIBRATORY COMPACTOR

Model: CB-14 VIBRATORY COMPACTOR DTT

Configuration: CB14 Vibratory Utility Compactor DTT00001-UP (MACHINE) POWERED BY C1.1 Engine

Disassembly and Assembly C1.1, C1.5 and C2.2 Engines for Caterpillar Built Machines

Media Number -KENR8103-03

Publication Date -01/02/2015

Date Updated -09/06/2016

i02848643

Engine Oil Pump - Install

SMCS - 1304-012

Installation Procedure

Table 1

Required Tools			
Tool	Part Number	Part Description	Qty
A ⁽¹⁾	256-4864	Alignment Tool	1
A ⁽²⁾	241-4232	Alignment Tool	1
B	1P-0808	Multipurpose Grease	1

⁽¹⁾ C1.1 engines

⁽²⁾ C1.5 and C2.2 engines

NOTICE

Keep all parts clean from contaminants.

Contaminants may cause rapid wear and shortened component life.

NOTICE

**If the front housing is not installed, do not turn the crankshaft.
Damage to the engine may occur.**

Idler Hub

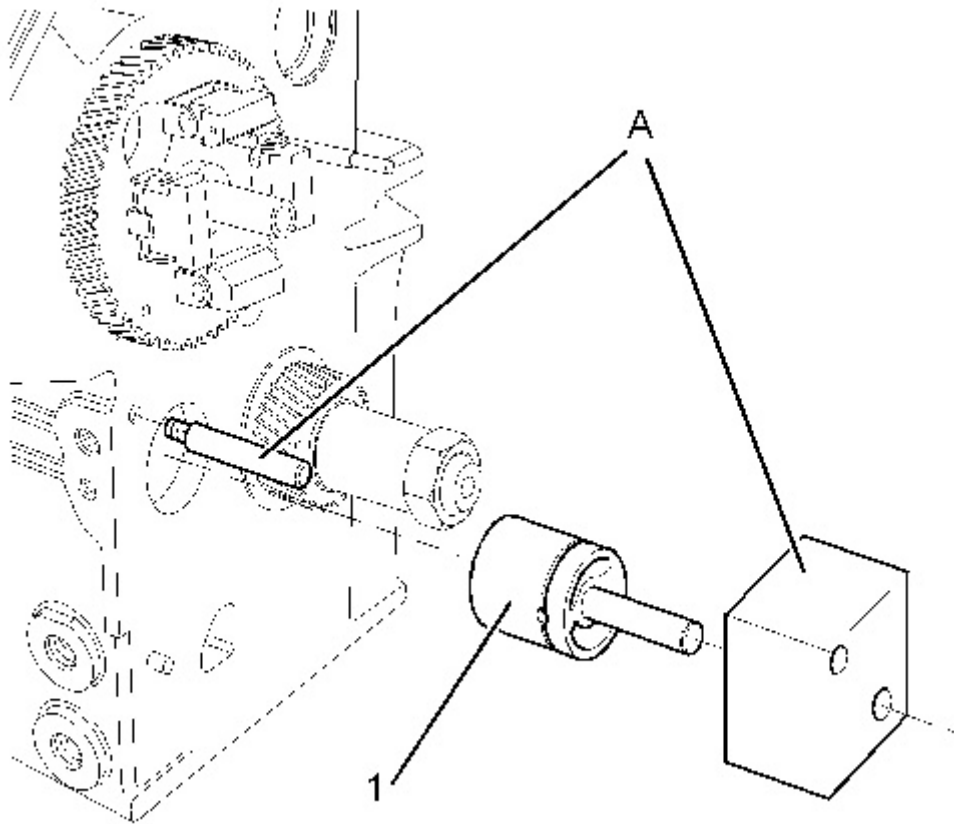

Illustration 1

g01297224

1. Install the pin of Tooling (A) to the cylinder block.
2. Position the guide plate of Tooling (A) onto idler hub (1). Align the guide plate of Tooling (A) with pin of Tooling (A).
3. Use a hammer in order to strike the guide plate of Tooling (A). This will install idler hub (1).
4. Remove Tooling (A).

Engine Oil Pump

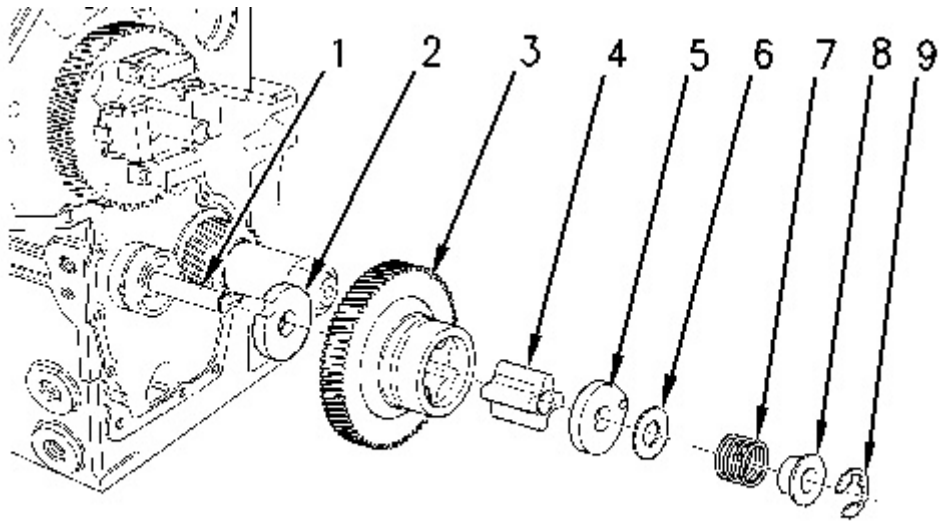

Illustration 2

g00825411

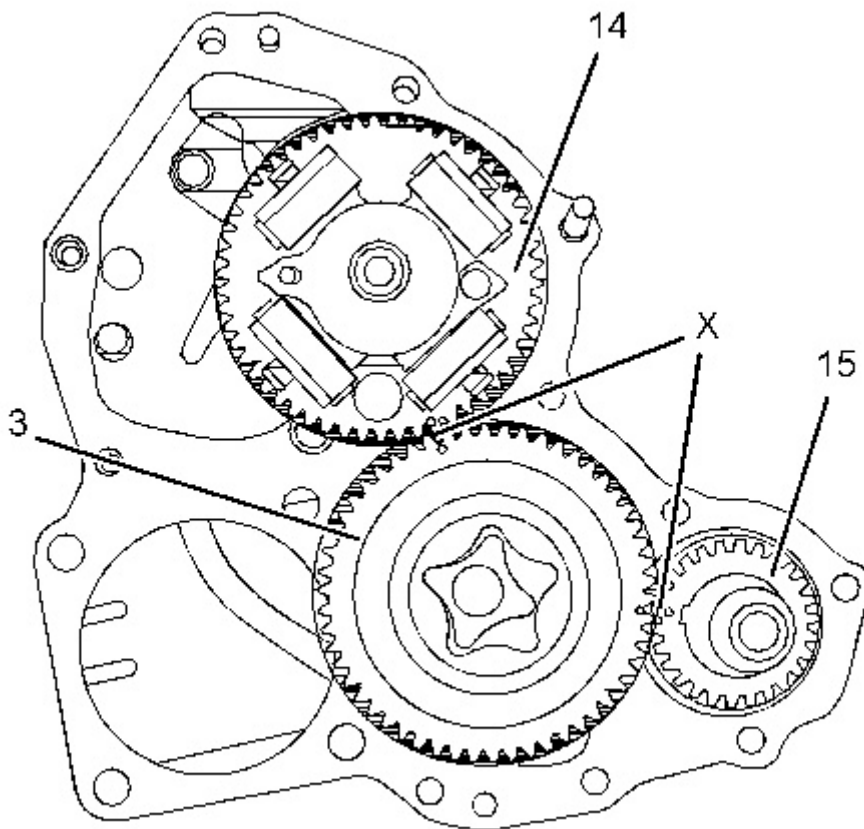

Illustration 3

g01297225



Improper assembly of parts that are spring loaded can cause bodily injury.

To prevent possible injury, follow the established assembly procedure and wear protective equipment.

1. Apply Tooling (B) to the faces of inner rotor (4) and to the vanes of idler gear (3).
2. Align timing marks (X) on idler gear (3) with the respective timing marks on gears (14) and (15). Install idler gear (3) onto idler hub (1).
3. Install inner rotor (4) to idler gear (3).



Personal injury can result from the release of the spring force.

The drive shaft, the piston, and the drive gear are under spring force.

Use a press to slowly release the spring force before the components are removed.

4. Install the following items to idler hub (1):
 - Oil pump cover (5)
 - Shim (6)
 - Spring (7)
 - Collar (8)

Refer to Illustration 2.

5. Install retaining ring (9) on idler hub (1).
-

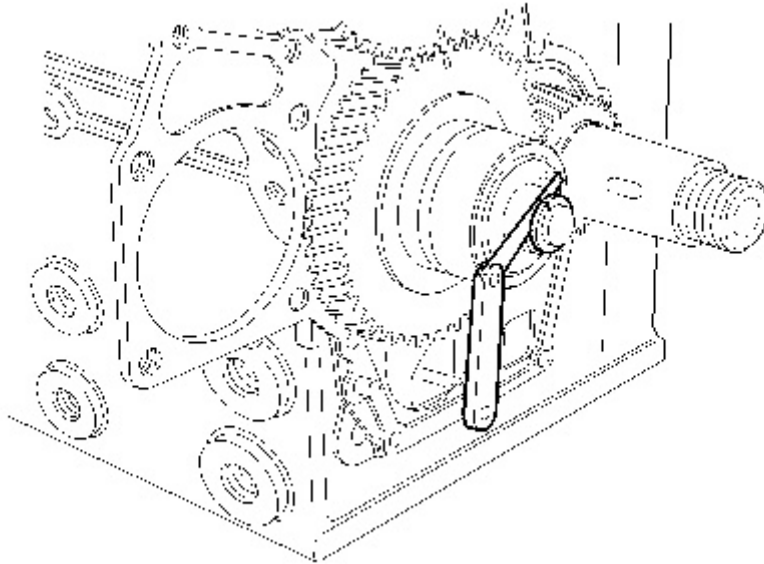

Illustration 4

g01298012

Checking end play by using a feeler gauge

6. Use a feeler gauge in order to measure the end play of engine oil pump. Refer to Specifications, "Engine Oil Pump".
7. If the oil strainer was removed, use the following procedure for installation:

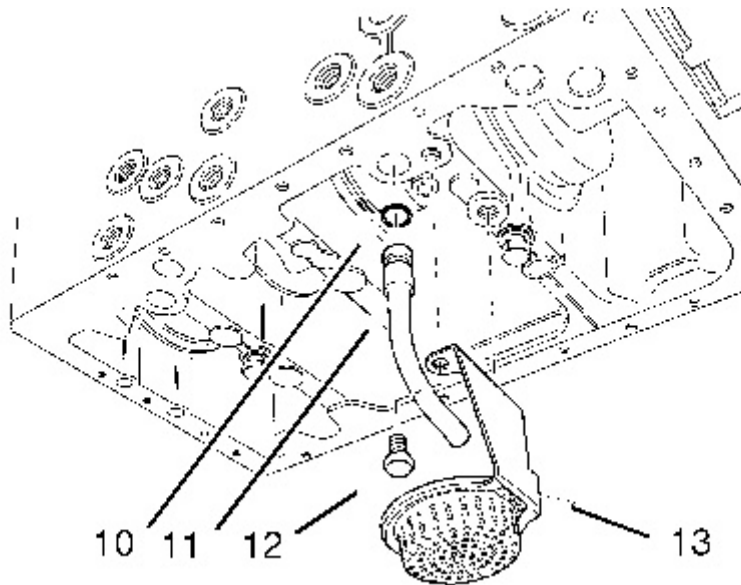

Illustration 5

g01037619

- a. Install a new O-ring seal (10) on oil tube assembly (11).
- b. Install oil tube assembly (11) in the cylinder block.
- c. Install oil strainer (13) to the cylinder block and tighten bolts (12) to a torque of 11 N·m (8 lb ft).

End By:

- a. Install the front housing. Refer to Disassembly and Assembly, "Housing (Front) - Install".
 - b. Install the engine oil pan. Refer to Disassembly and Assembly, "Engine Oil Pan - Remove and Install".
-

Product: VIBRATORY COMPACTOR

Model: CB-14 VIBRATORY COMPACTOR DTT

Configuration: CB14 Vibratory Utility Compactor DTT00001-UP (MACHINE) POWERED BY C1.1 Engine

Disassembly and Assembly C1.1, C1.5 and C2.2 Engines for Caterpillar Built Machines

Media Number -KENR8103-03

Publication Date -01/02/2015

Date Updated -09/06/2016

i02736139

Water Pump - Remove

SMCS - 1361-011

Removal Procedure

Start By:

- a. Remove the fan. Refer to Disassembly and Assembly, "Fan - Remove and Install".
- b. Remove the alternator. Refer to Disassembly and Assembly, "Alternator - Remove and Install".

NOTICE

Keep all parts clean from contaminants.

Contaminants may cause rapid wear and shortened component life.

NOTICE

Care must be taken to ensure that fluids are contained during performance of inspection, maintenance, testing, adjusting, and repair of the product. Be prepared to collect the fluid with suitable containers before opening any compartment or disassembling any component containing fluids.

Refer to Special Publication, NENG2500, "Dealer Service Tool Catalog" for tools and supplies suitable to collect and contain fluids on Cat products.

Dispose of all fluids according to local regulations and mandates.

1. Drain the coolant from the cooling system into a suitable container for storage or disposal. Refer to Operation and Maintenance Manual, "Refill Capacities" for the approximate capacity of the cooling system.
 2. Loosen the clamps and remove the hose from the water pump inlet (not shown).
-

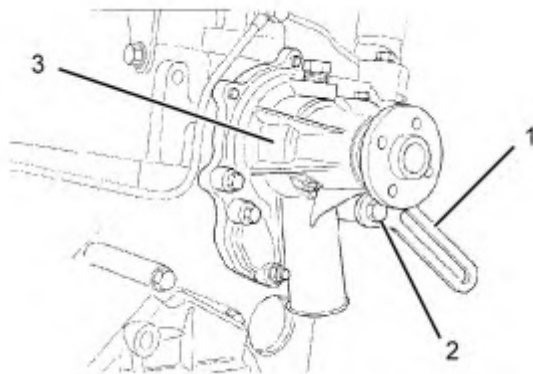
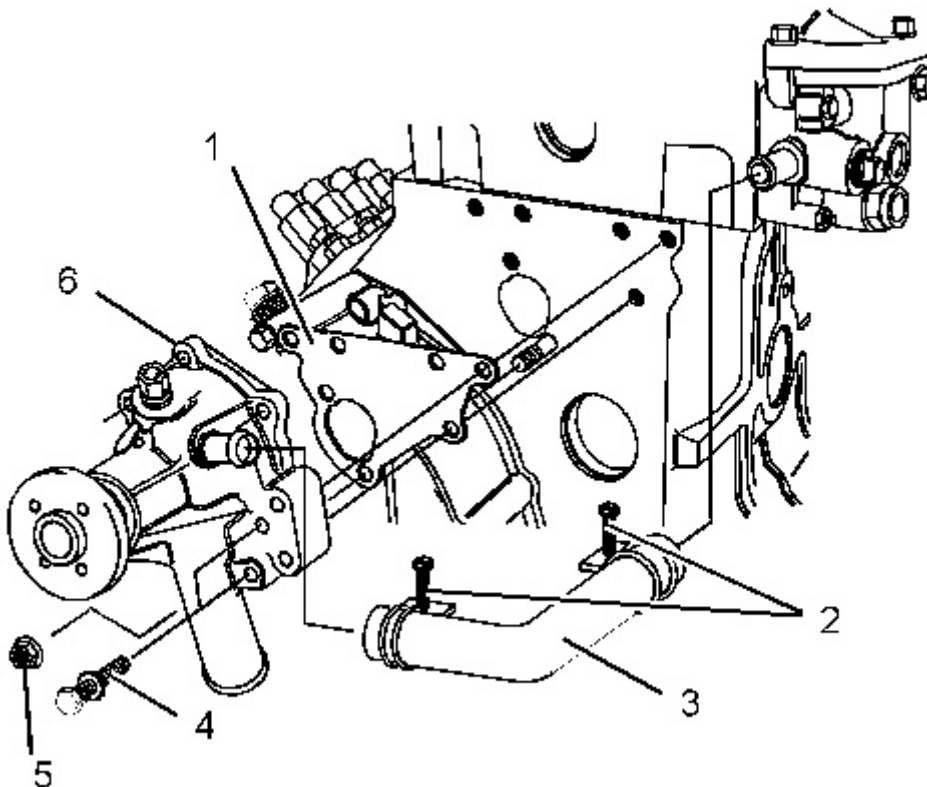

Illustration 1

g01372127

Typical example

3. Remove the fasteners (2) and the alternator bracket (1) from the water pump (3).
-



Typical example

4. Loosen the clamps (2) and remove the bypass hose (3) from the water pump (6).
 5. Remove the setscrews, the washers (4) and the nut (5).
 6. If necessary, gently tap the water pump (6) with a soft faced hammer in order to loosen the water pump (6).
 7. Remove the water pump (6). Remove the joint (1) from the cylinder block. Discard the joint (1).
-

Product: VIBRATORY COMPACTOR

Model: CB-14 VIBRATORY COMPACTOR DTT

Configuration: CB14 Vibratory Utility Compactor DTT00001-UP (MACHINE) POWERED BY C1.1 Engine

Disassembly and Assembly C1.1, C1.5 and C2.2 Engines for Caterpillar Built Machines

Media Number -KENR8103-03

Publication Date -01/02/2015

Date Updated -09/06/2016

i02736650

Water Pump - Install

SMCS - 1361-012

Installation Procedure

NOTICE

Keep all parts clean from contaminants.

Contaminants may cause rapid wear and shortened component life.

1. Remove all debris and gasket material from the mating surfaces of the water pump and the cylinder block.
-

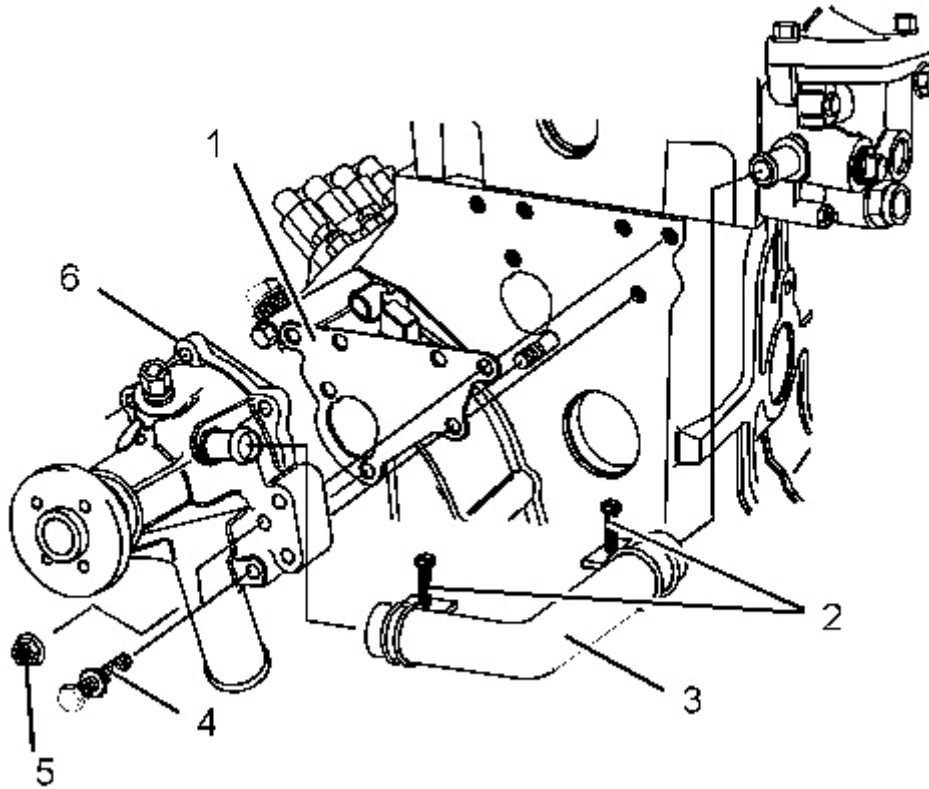

Illustration 1
Typical example

g01372128

2. Install a new gasket (1) in position on the engine.
3. Place the water pump (6) in position on the engine and install the setscrews, the washers (4) and the nut (5). Tighten setscrews, the washers (4) and the nut (5) to a torque of 10 N·m (7.4 lb ft).

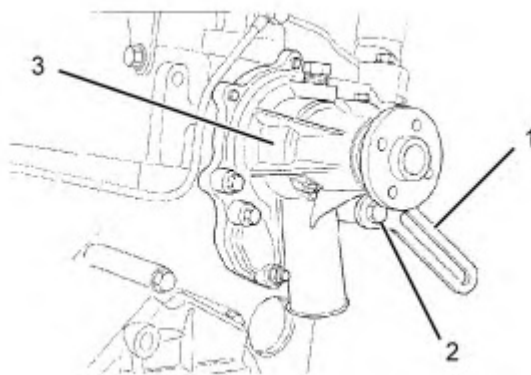

Illustration 2
Typical example

g01372127

4. Place the alternator bracket (1) into position on water pump (6). Install the fasteners (2) on the water pump (6) and hand tighten the fasteners (2).
5. Install the lower hose and install the hose clamp (not shown). Hand tighten the hose clamp. Install the hose (3) on the water pump (6) and tighten the hose clamps (2) to a torque of 2.5 N·m (22.1 lb in).

End By:

- a. Install the fan. Refer to Disassembly and Assembly, "Fan - Remove and Install".
 - b. Install the V-Belts. Refer to Disassembly and Assembly, "V-Belts - Remove and Install".
-

Product: VIBRATORY COMPACTOR

Model: CB-14 VIBRATORY COMPACTOR DTT

Configuration: CB14 Vibratory Utility Compactor DTT00001-UP (MACHINE) POWERED BY C1.1 Engine

Disassembly and Assembly C1.1, C1.5 and C2.2 Engines for Caterpillar Built Machines

Media Number -KENR8103-03

Publication Date -01/02/2015

Date Updated -09/06/2016

i02234872

Water Temperature Regulator Housing - Remove and Install

SMCS - 1393-010

Removal Procedure

NOTICE

Keep all parts clean from contaminants.

Contaminants may cause rapid wear and shortened component life.

NOTICE

Care must be taken to ensure that fluids are contained during performance of inspection, maintenance, testing, adjusting, and repair of the product. Be prepared to collect the fluid with suitable containers before opening any compartment or disassembling any component containing fluids.

Refer to Special Publication, NENG2500, "Dealer Service Tool Catalog" for tools and supplies suitable to collect and contain fluids on Cat products.

Dispose of all fluids according to local regulations and mandates.

1. Drain the coolant from the cooling system into a suitable container for storage or disposal. Refer to the OEM for the approximate capacity of the cooling system. Refer to the

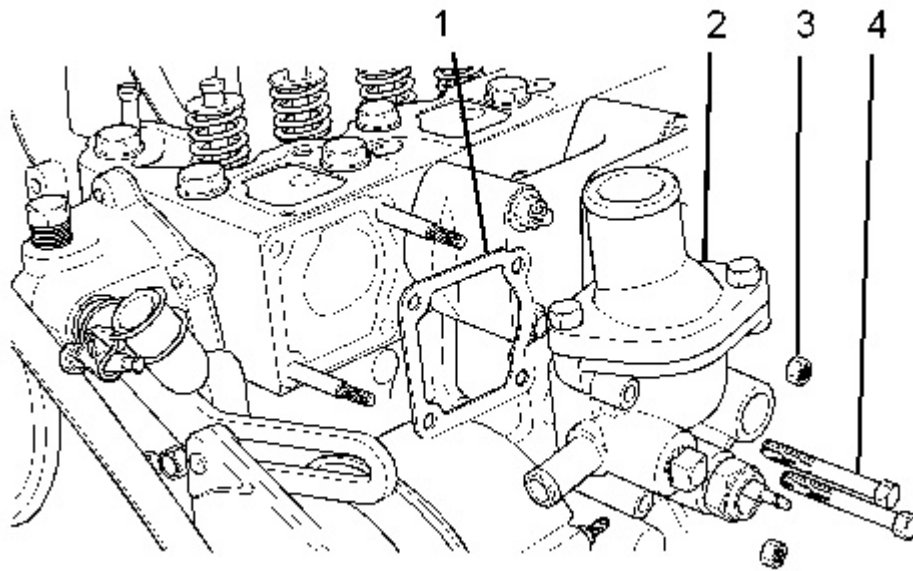

Illustration 1
Typical example

g01124076

2. Remove the setscrews (4) and the nuts (3).
3. Remove the water temperature regulator housing (2) from the cylinder head.
4. Remove the gasket (1) from the cylinder head. Discard the gasket.

Installation Procedure

NOTICE

Keep all parts clean from contaminants.

Contaminants may cause rapid wear and shortened component life.

1. Clean the mating surfaces of the cylinder head. Clean the mating surfaces of the water temperature regulator housing.
-

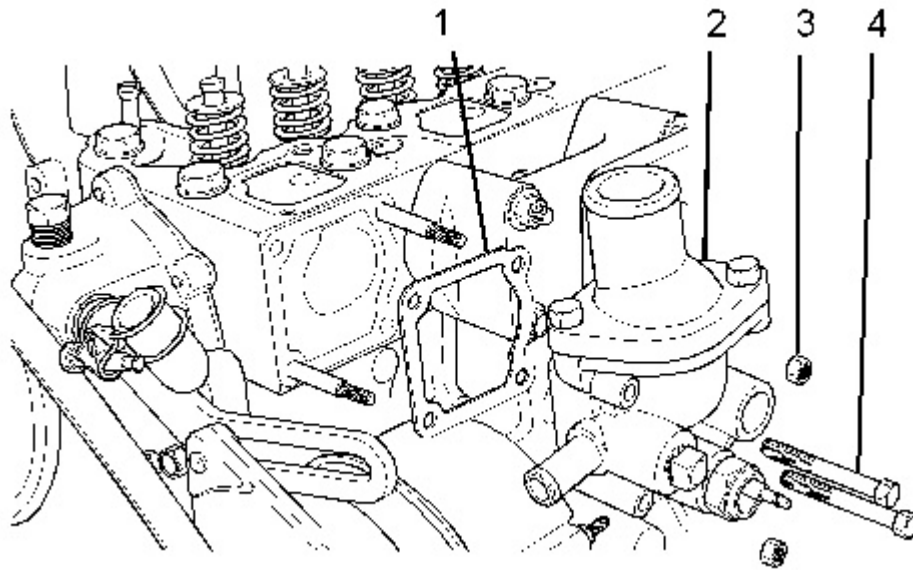

Illustration 2

g01124076

Typical example

2. Install a new gasket (1) on the cylinder head.
 3. Install the water temperature regulator housing (2) to the cylinder head.
 4. Install the setscrews (4) and the nuts (3) that fasten the water temperature regulator housing to the cylinder head. Tighten the fasteners to a torque of 10 N·m (7.4 lb ft).
 5. Fill the cooling system with coolant to the correct level. Refer to the Operation and Maintenance Manual, "Refill Capacities" for more information.
-

Product: VIBRATORY COMPACTOR

Model: CB-14 VIBRATORY COMPACTOR DTT

Configuration: CB14 Vibratory Utility Compactor DTT00001-UP (MACHINE) POWERED BY C1.1 Engine

Disassembly and Assembly C1.1, C1.5 and C2.2 Engines for Caterpillar Built Machines

Media Number -KENR8103-03

Publication Date -01/02/2015

Date Updated -09/06/2016

i02736651

Water Temperature Regulator - Remove and Install

SMCS - 1355-010

Removal Procedure

NOTICE

Keep all parts clean from contaminants.

Contaminants may cause rapid wear and shortened component life.

NOTICE

Care must be taken to ensure that fluids are contained during performance of inspection, maintenance, testing, adjusting, and repair of the product. Be prepared to collect the fluid with suitable containers before opening any compartment or disassembling any component containing fluids.

Refer to Special Publication, NENG2500, "Dealer Service Tool Catalog" for tools and supplies suitable to collect and contain fluids on Cat products.

Dispose of all fluids according to local regulations and mandates.

1. Drain the coolant from the cooling system into a suitable container for storage or disposal. Refer to Operation and Maintenance Manual, "Refill Capacities" for the approximate capacity of the cooling system.

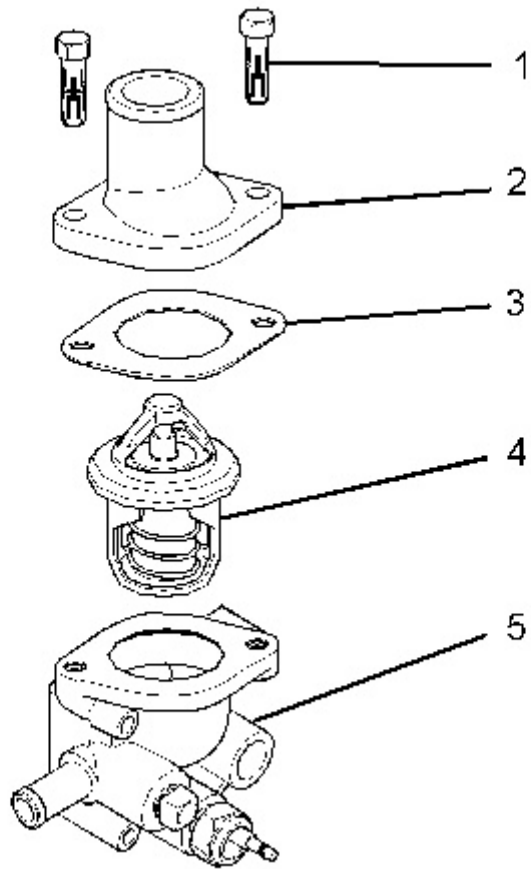

Illustration 1
Typical example

g01125880

2. Remove the setscrews (1).
3. Remove the outlet connection (2) for the water temperature regulator.
Note: Identify the orientation of the outlet connection for installation.
4. Remove the joint (3).
5. Remove the water temperature regulator (4) from the water temperature regulator housing (5).
6. Inspect the water temperature regulator (4) for wear or damage. If the water temperature regulator is worn or damaged, use a new part for replacement. Refer to Systems Operation, Testing and Adjusting, "Water Temperature Regulator - Test" for more information on testing the water temperature regulator.

Installation Procedure

NOTICE

Keep all parts clean from contaminants.



Suggest:

For more complete manuals. Please go to the home page.

<https://www.ebooklibonline.com>

If the above button click is invalid. Please download this document first, and then click the above link to download the complete manual.

Thank you so much for reading

Contaminants may cause rapid wear and shortened component life.

NOTICE

Care must be taken to ensure that fluids are contained during performance of inspection, maintenance, testing, adjusting, and repair of the product. Be prepared to collect the fluid with suitable containers before opening any compartment or disassembling any component containing fluids.

Refer to Special Publication, NENG2500, "Dealer Service Tool Catalog" for tools and supplies suitable to collect and contain fluids on Cat products.

Dispose of all fluids according to local regulations and mandates.

1. Remove all debris and all gasket material from the mating surfaces of both the outlet connection (2) and the water temperature regulator housing (5).

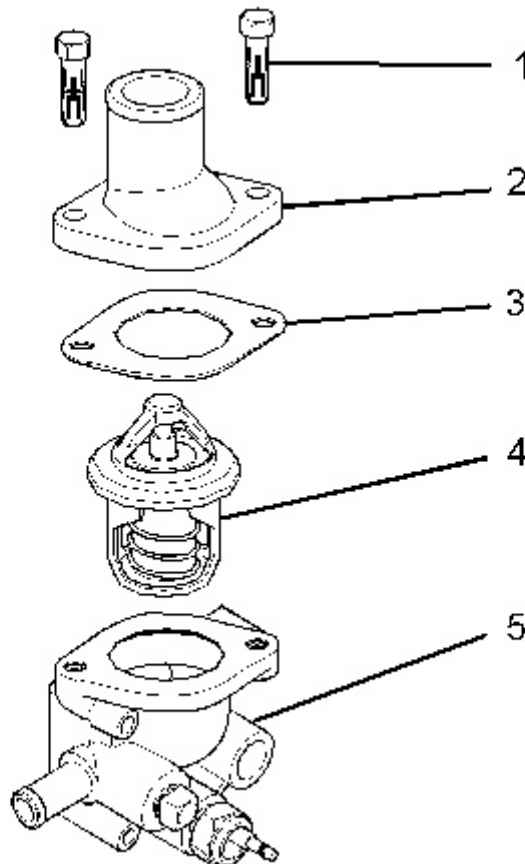

2. Install the water temperature regulator (4) to the water temperature regulator housing (5). Refer to Specifications, "Water Regulator Housing" for the correct orientation of the water temperature regulator.
 3. Install a new joint (3) to the cylinder head.
 4. Install the outlet connection (2) to the water temperature regulator housing (5).
Note: Ensure the correct orientation of the outlet connection.
 5. Install the setscrews (1) to the outlet connection (2).
 6. Tighten the setscrews to a torque of 14 N·m (10 lb ft).
 7. Fill the cooling system with coolant to the correct level. Refer to Operation and Maintenance Manual, "Refill Capacities" for more information.
-

<https://www.ebooklibonline.com>

Hello dear friend!

Thank you very much for reading.

Enter the link into your browser.

The full manual is available for immediate download.

<https://www.ebooklibonline.com>