

Product: VIBRATORY COMPACTOR

Model: CB-14 VIBRATORY COMPACTOR DST

Configuration: CB14 Vibratory Compactor DST00001-UP (MACHINE) POWERED BY C1.1 Engine

Disassembly and Assembly

C1.1, C1.5 and C2.2 Engines for Caterpillar Built Machines

Media Number -KENR8103-03

Publication Date -01/02/2015

Date Updated -09/06/2016

i02736119

Inlet and Exhaust Valves - Remove and Install

SMCS - 1105-010

Removal Procedure

Table 1

Required Tools			
Tool	Part Number	Part Description	Qty
A	9U-6195	Valve Spring Compressor	1

Start By:

- a. Remove the cylinder head. Refer to Disassembly and Assembly, "Cylinder Head - Remove".

NOTICE

Keep all parts clean from contaminants.

Contaminants may cause rapid wear and shortened component life.

1. Clean the bottom face of the cylinder head. Check the depth of the valves below the face of the cylinder head before the valve springs are removed. Refer to Specifications, "Cylinder Head Valves" for the correct dimensions.

2. Place an identification mark on the heads of the valves for installation purposes.

Note: The head of the inlet valve has a larger diameter than the head of the exhaust valve.

3. Position the cylinder head on a suitable surface with the valve springs facing upward.

Note: Ensure that the machined face of the cylinder head is kept on a clean, soft surface in order to prevent damage to the machined surface.

WARNING

Personal injury can result from being struck by parts propelled by a released spring force.

Make sure to wear all necessary protective equipment.

Follow the recommended procedure and use all recommended tooling to release the spring force.

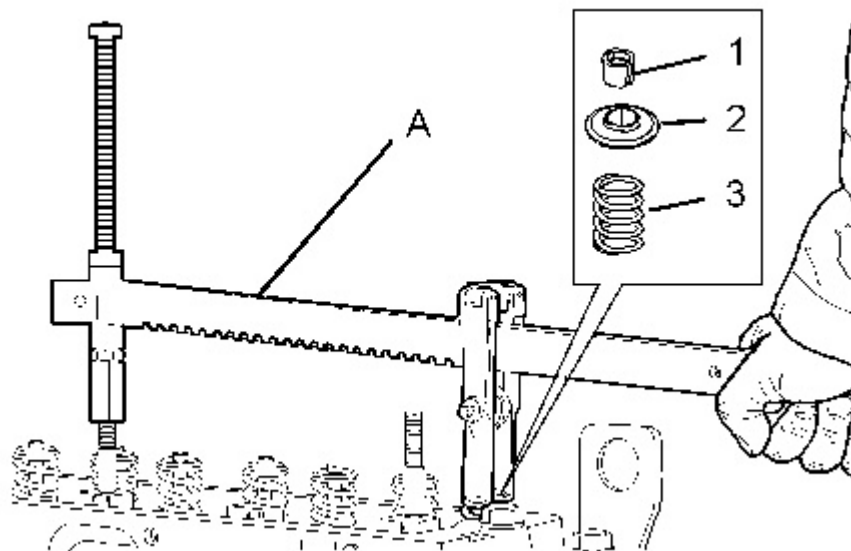

Illustration 1
Typical example

g01129177

4. Install tool (A) in position on the cylinder head in order to compress the appropriate valve spring (3).

NOTICE

Ensure that the valve spring is compressed squarely or damage to the valve stem may occur.

5. Apply pressure to tool (A). Remove the valve keepers (1).
6. Slowly release the pressure on tool (A).

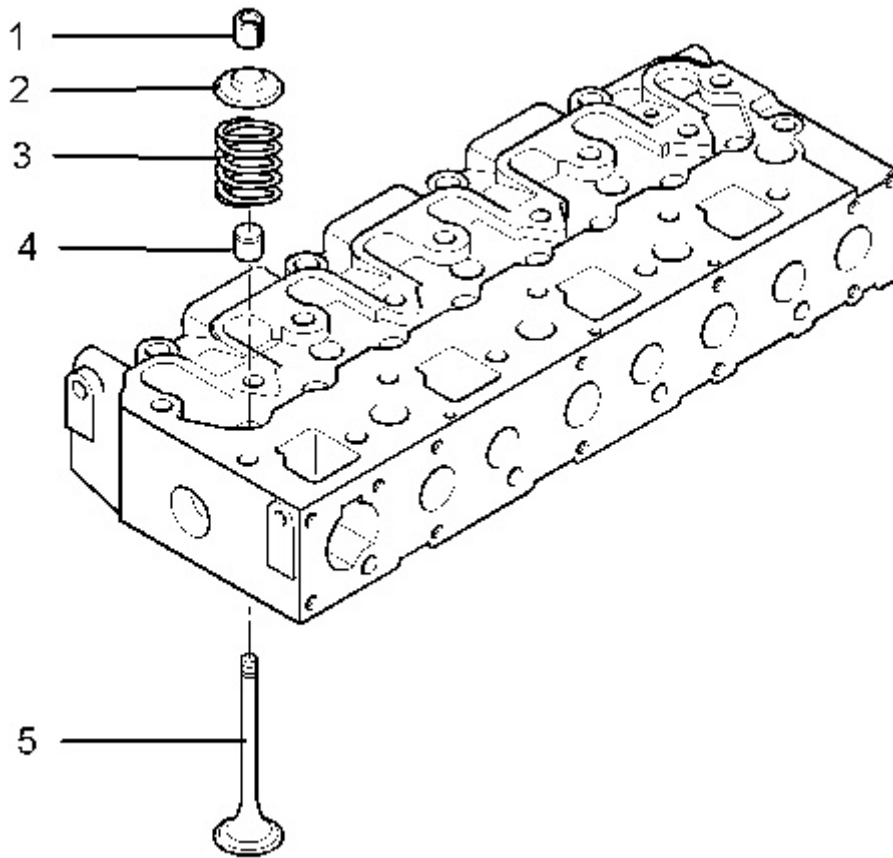

Illustration 2
Typical example

g01129220

7. Remove the valve spring retainer (2).
8. Remove valve spring (3).
9. Repeat steps 4 to 8 for the remaining valves.
10. Remove tool (A).
11. Remove the valve stem seals (4).
12. Carefully turn over the cylinder head.
13. Remove the valves (5).

Installation Procedure

Table 2

Required Tools			
Tool	Part Number	Part Description	Qty
A	9U-6195	Valve Spring Compressor	1

<https://www.ebooklibonline.com>

Hello dear friend!

Thank you very much for reading.

Enter the link into your browser.

The full manual is available for immediate download.

<https://www.ebooklibonline.com>

NOTICE

Keep all parts clean from contaminants.

Contaminants may cause rapid wear and shortened component life.

1. Clean all parts. Ensure that all ports, all coolant passages and all lubrication passages are free from debris. To inspect the cylinder head, refer to Systems Operation, Testing and Adjusting, "Cylinder Head Inspect" for further information.
 2. Inspect all of the valve seats for wear and for damage. Refer to Specifications, "Cylinder Head Valves" and refer to Systems Operation, Testing and Adjusting, "Valve Depth - Inspect " for further information.
 3. Inspect all of the valve guides for wear and for damage. Refer to Specifications, "Cylinder Head Valves" and refer to Systems Operation, Testing and Adjusting, "Valve Guide - Inspect" for further information.
-

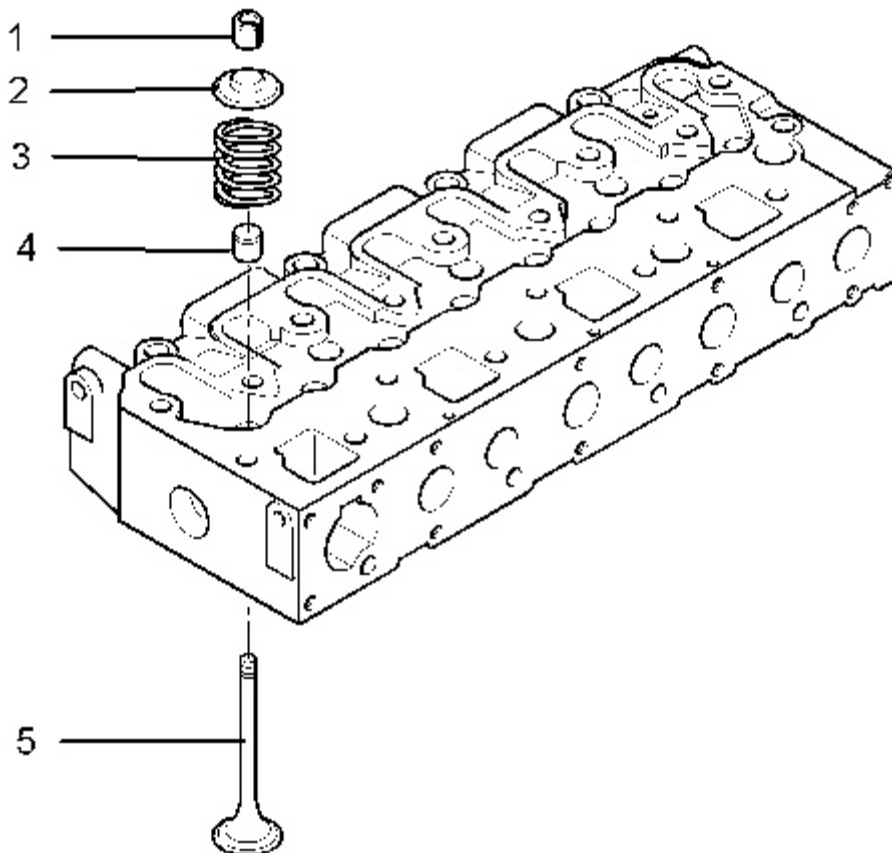

Illustration 3
Typical example

g01129220

4. Lubricate the stems of all valves (5) with clean engine oil. Install the valves (5) in the appropriate positions.

5. Carefully turn over the cylinder head and ensure that all of the valves remain in place.
6. Use a suitable tool to install the new valve stem seals (4) onto each of the valve guides.

Note: The outer face of the valve guides must be clean and dry before installing the valve stem seals (4). The inlet valve stem and the exhaust valve stem use seals that are different parts.

7. Inspect the valve springs (3) for wear and for the correct installed length. Refer to Specifications, "Cylinder Head Valves " for further information.
8. Install the valve spring (3) onto the cylinder head.
9. Install the valve spring retainer (2).



Personal injury can result from being struck by parts propelled by a released spring force.

Make sure to wear all necessary protective equipment.

Follow the recommended procedure and use all recommended tooling to release the spring force.

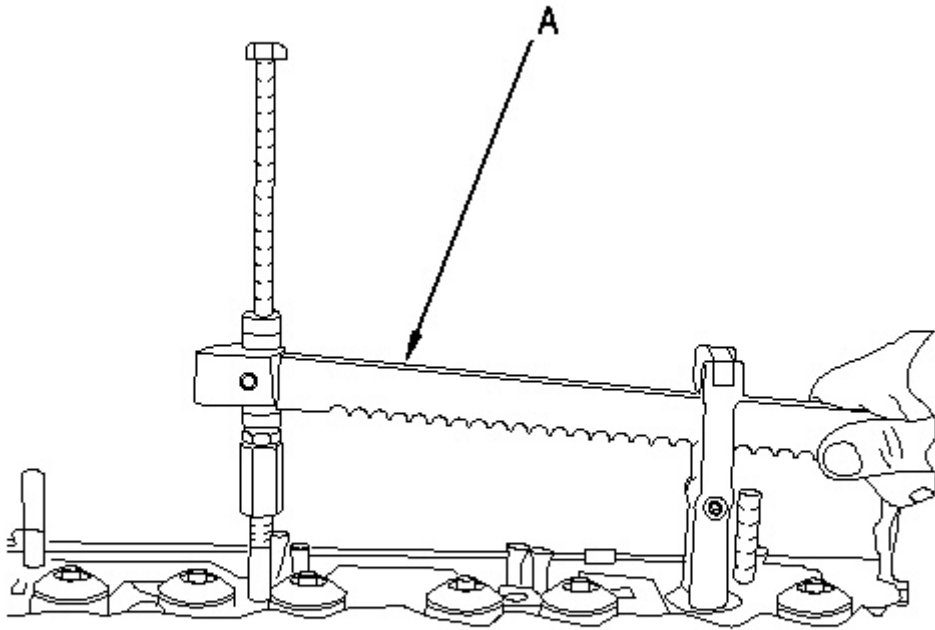

Illustration 4
Typical example

g00825742

10. Install tool (A) in position on the cylinder head in order to compress the appropriate valve spring (3).

NOTICE

Ensure that the valve spring is compressed squarely or damage to the valve stem may occur.

11. Apply pressure to tool (A). Install the valve keepers (1).



The valve spring keepers can be thrown from the valve when the valve spring compressor is released. Ensure that the valve spring keepers are properly installed on the valve stem. To help prevent personal injury, keep away from the front of the valve spring keepers and valve springs during the installation of the valves.

-
12. Carefully release the pressure on tool (A).
 13. Repeat steps 8 to 12 for all of the valves.
 14. Remove tool (A) from the cylinder head.
 15. Place the cylinder head on a suitable support. Ensure that the heads of the valves are not obstructed. Gently strike the top of the valves with a soft hammer in order to ensure that the valve keepers (1) are properly installed.
 16. Turn over the cylinder head and check the depth of the valves below the face of the cylinder head. Refer to Specifications, "Cylinder Head Valves" for more information.

End By:

- a. Install the cylinder head. Refer to Disassembly and Assembly, "Cylinder Head - Install".
-

Product: VIBRATORY COMPACTOR

Model: CB-14 VIBRATORY COMPACTOR DST

Configuration: CB14 Vibratory Compactor DST00001-UP (MACHINE) POWERED BY C1.1 Engine

Disassembly and Assembly C1.1, C1.5 and C2.2 Engines for Caterpillar Built Machines

Media Number -KENR8103-03

Publication Date -01/02/2015

Date Updated -09/06/2016

i02848641

Engine Oil Line - Remove and Install

SMCS - 1307-010

Removal Procedure

NOTICE

Keep all parts clean from contaminants.

Contaminants may cause rapid wear and shortened component life.

NOTICE

Care must be taken to ensure that fluids are contained during performance of inspection, maintenance, testing, adjusting, and repair of the product. Be prepared to collect the fluid with suitable containers before opening any compartment or disassembling any component containing fluids.

Refer to Special Publication, NENG2500, "Dealer Service Tool Catalog" for tools and supplies suitable to collect and contain fluids on Cat products.

Dispose of all fluids according to local regulations and mandates.

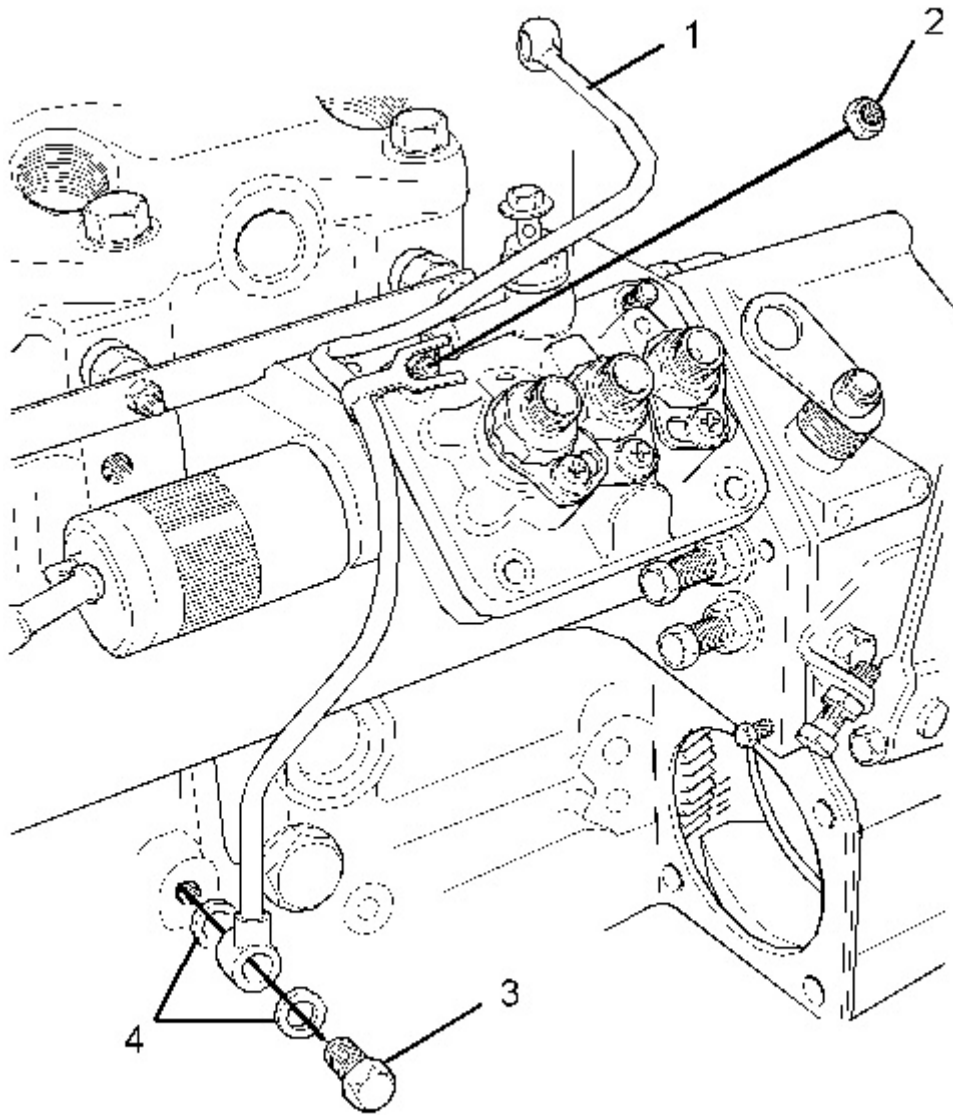

Illustration 1
Typical example

g01117696

1. Loosen the nut (2) that attaches the oil line (1) to the cylinder block.
 2. Remove the banjo bolt (3) and remove the washers (4) from the cylinder block. Discard the washers (4).
-

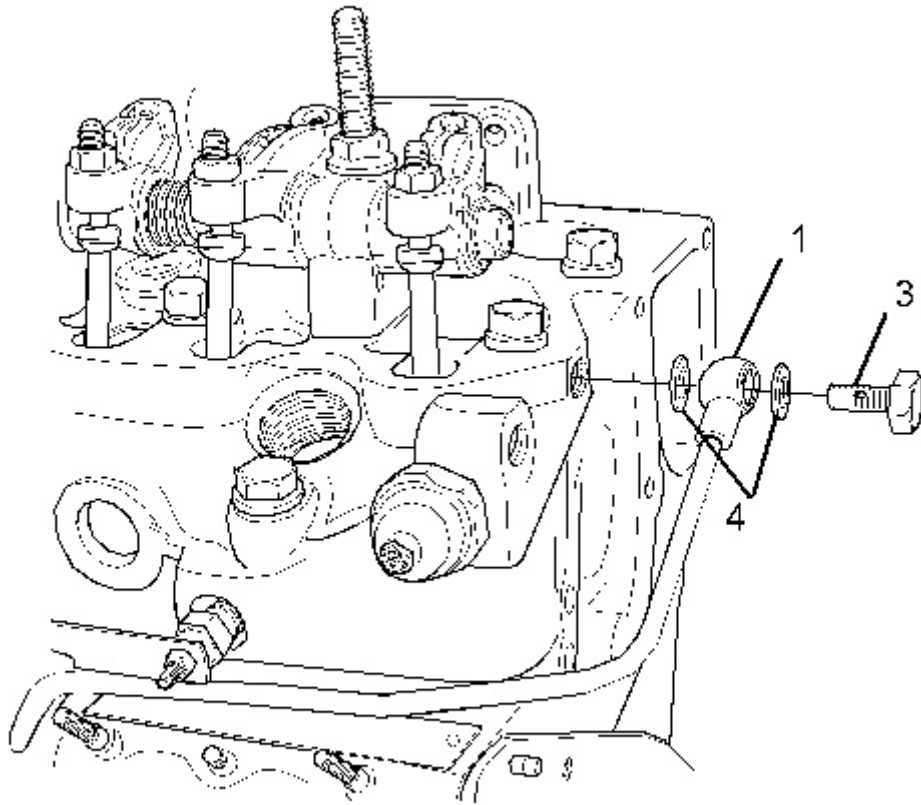

Illustration 2
Typical example

g01117697

3. Remove the banjo bolt (3) and remove the washers (4) from the cylinder head. Discard the washers (4).
4. Remove the oil line (1) from the engine.

Installation Procedure

NOTICE

Keep all parts clean from contaminants.

Contaminants may cause rapid wear and shortened component life.

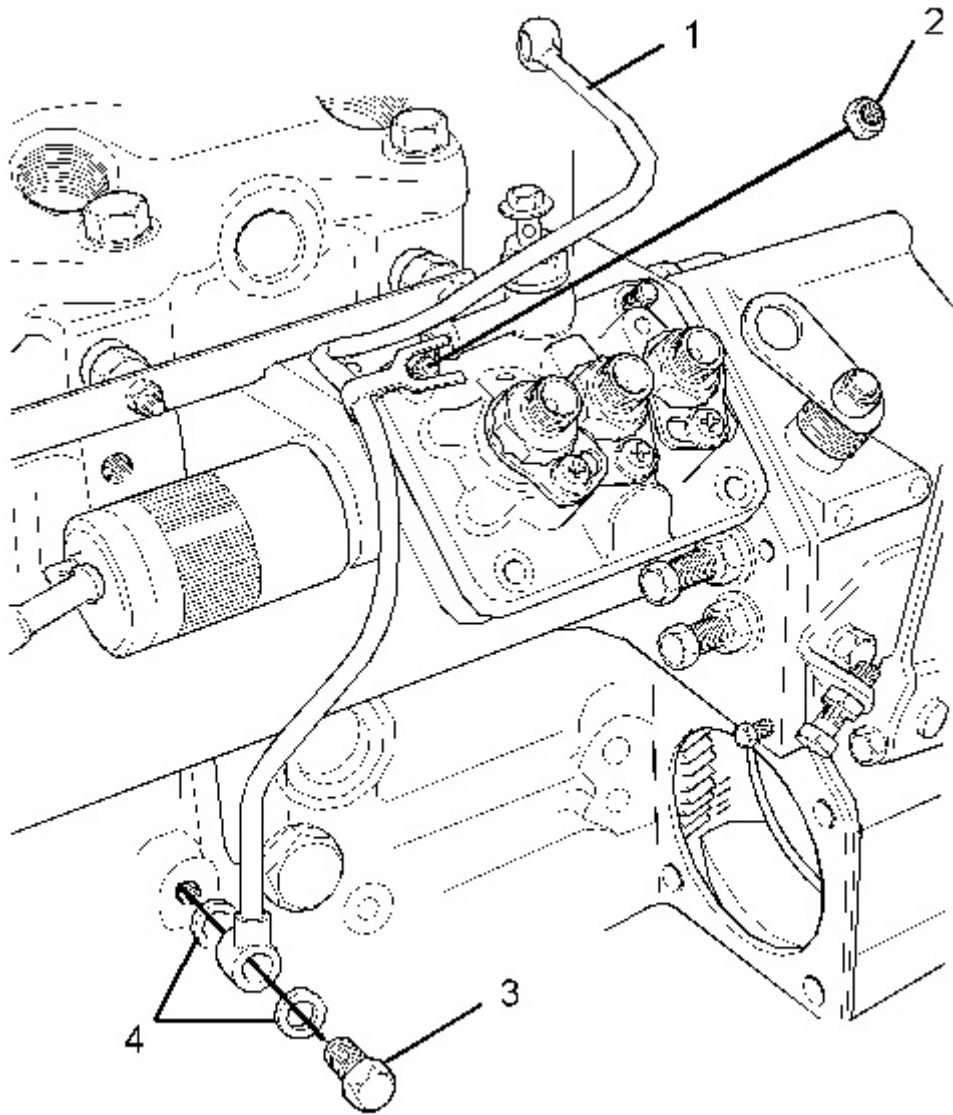

Illustration 3
Typical example

g01117696

1. Position the oil line (1) on the engine.
 2. Position the banjo bolt (3) and the new washers (4) on the oil line (1). Install the oil line to the cylinder block.
-

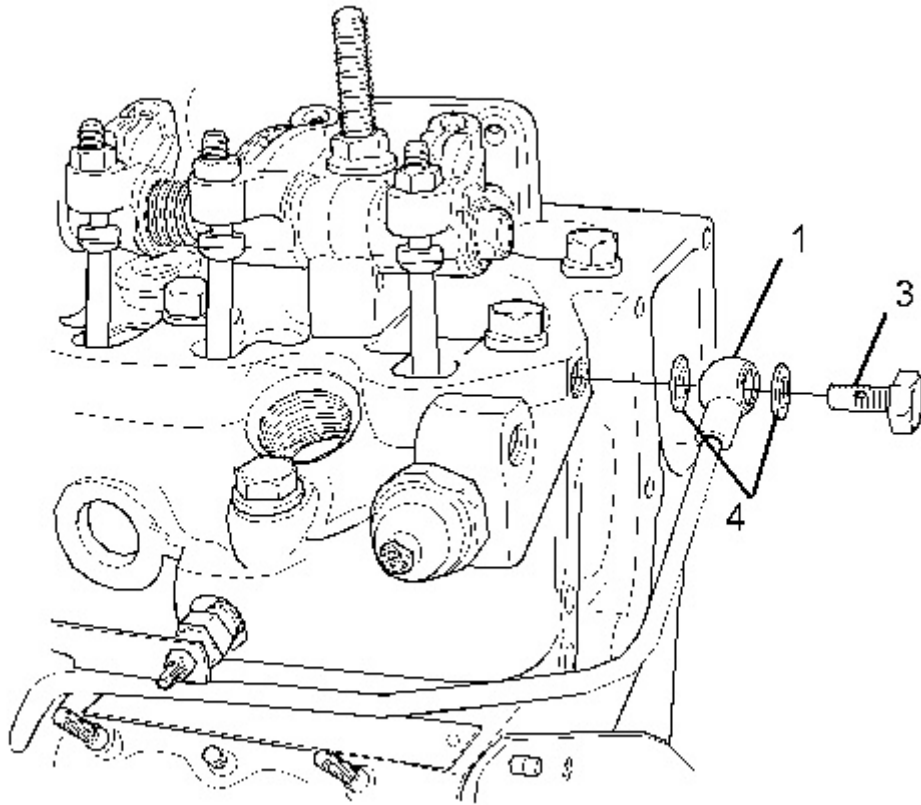

Illustration 4

g01117697

Typical example

3. Position the banjo bolt (3) and the new washers (4) to the oil line (1). Install the oil line to the cylinder head.
 4. For C1.1 engines, install the nut (2) that attaches the oil line (1) to the cylinder block. Tighten the nut (2) to a torque of 6 N·m (4.4 lb ft). For C1.5 and C2.2 engines, install the nut (2) that attaches the oil line (1) to the cylinder block. Tighten the nut (2) to a torque of 15 N·m (11 lb ft).
 5. Tighten the banjo bolts (3) to 11.5 N·m (8.5 lb ft).
-

Product: VIBRATORY COMPACTOR

Model: CB-14 VIBRATORY COMPACTOR DST

Configuration: CB14 Vibratory Compactor DST00001-UP (MACHINE) POWERED BY C1.1 Engine

Disassembly and Assembly C1.1, C1.5 and C2.2 Engines for Caterpillar Built Machines

Media Number -KENR8103-03

Publication Date -01/02/2015

Date Updated -09/06/2016

i02236297

Engine Oil Relief Valve - Remove and Install

SMCS - 1315-010

Removal Procedure

NOTICE

Keep all parts clean from contaminants.

Contaminants may cause rapid wear and shortened component life.

NOTICE

Care must be taken to ensure that fluids are contained during performance of inspection, maintenance, testing, adjusting, and repair of the product. Be prepared to collect the fluid with suitable containers before opening any compartment or disassembling any component containing fluids.

Refer to Special Publication, NENG2500, "Dealer Service Tool Catalog" for tools and supplies suitable to collect and contain fluids on Cat products.

Dispose of all fluids according to local regulations and mandates.

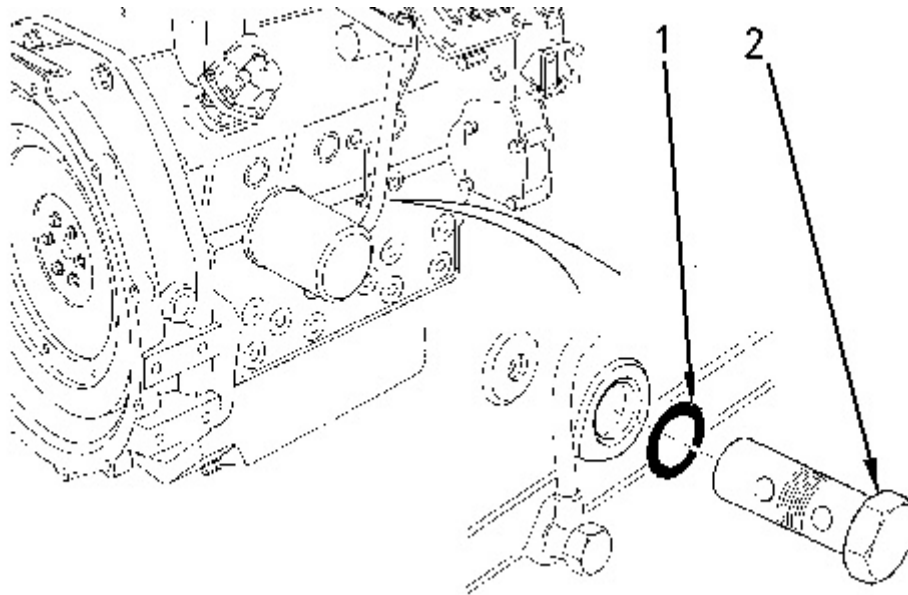

Illustration 1

g00820218

1. Remove the engine oil relief valve (2) from the cylinder block.
2. Remove the O-ring (1) from the engine oil relief valve. Discard the O-ring.

Installation Procedure

NOTICE

Keep all parts clean from contaminants.

Contaminants may cause rapid wear and shortened component life.

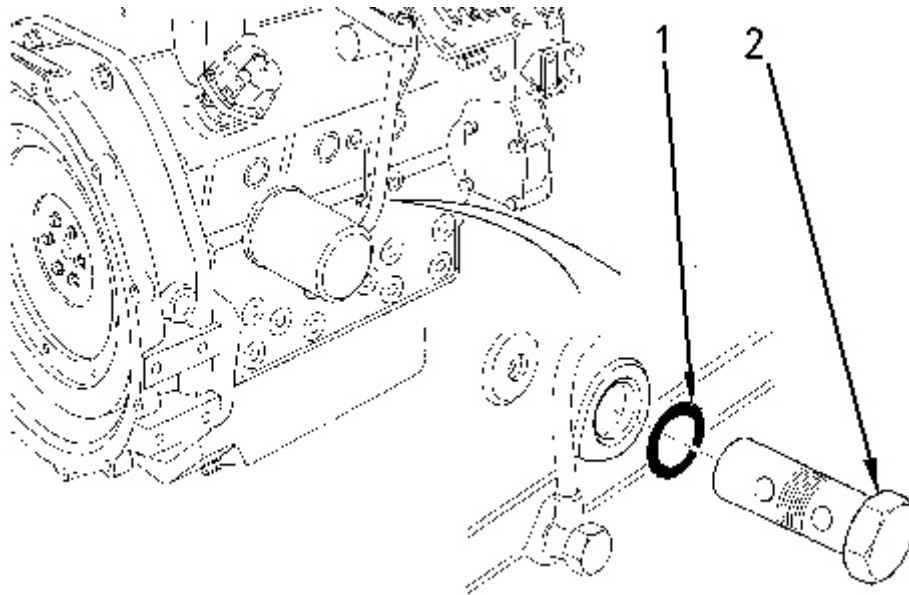

Illustration 2

g00820218

1. Install a new O-ring (1) on the engine oil relief valve (2).
 2. Lubricate the engine oil relief valve (2) with clean engine oil.
 3. Install the engine oil relief valve (2) in the cylinder block. Tighten the engine oil relief valve to a torque of 64 N·m (47 lb ft).
-

Product: VIBRATORY COMPACTOR

Model: CB-14 VIBRATORY COMPACTOR DST

Configuration: CB14 Vibratory Compactor DST00001-UP (MACHINE) POWERED BY C1.1 Engine

Disassembly and Assembly C1.1, C1.5 and C2.2 Engines for Caterpillar Built Machines

Media Number -KENR8103-03

Publication Date -01/02/2015

Date Updated -09/06/2016

i02236295

Engine Oil Pump - Remove

SMCS - 1304-011

Removal Procedure

Start By:

- a. Remove the engine oil pan. Refer to Disassembly and Assembly, "Engine Oil Pan - Remove and Install".
- b. Remove the front housing. Refer to Disassembly and Assembly, "Housing (Front) - Remove".

NOTICE

Keep all parts clean from contaminants.

Contaminants may cause rapid wear and shortened component life.

NOTICE

**If the front housing is not installed, do not turn the crankshaft.
Damage to the engine may occur.**

NOTICE

Care must be taken to ensure that fluids are contained during performance of inspection, maintenance, testing, adjusting, and repair of the product. Be prepared to collect the fluid with suitable containers before opening any compartment or disassembling any component containing fluids.

Refer to Special Publication, NENG2500, "Dealer Service Tool Catalog" for tools and supplies suitable to collect and contain fluids on Cat products.

Dispose of all fluids according to local regulations and mandates.

Engine Oil Pump

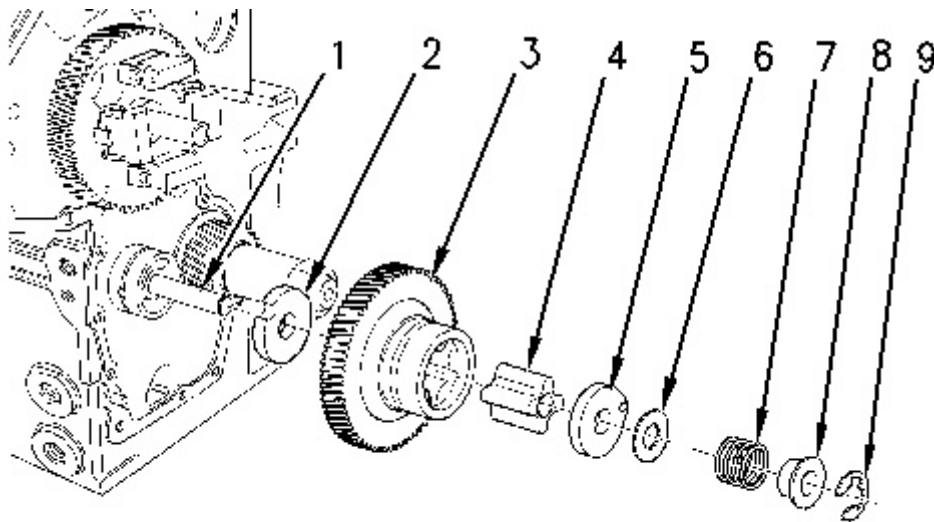

Illustration 1

g00825411

WARNING

Personal injury can result from being struck by parts propelled by a released spring force.

Make sure to wear all necessary protective equipment.

Follow the recommended procedure and use all recommended tooling to release the spring force.

-
1. Remove the C-clip (9) that retains the idler gear (3) on the idler hub (1).



Suggest:

For more complete manuals. Please go to the home page.

<https://www.ebooklibonline.com>

If the above button click is invalid. Please download this document first, and then click the above link to download the complete manual.

Thank you so much for reading

2. Remove the following items from the idler hub (1):

- Collar (8)
- Spring (7)
- Shim (6)
- Oil pump cover (5)
- Inner rotor (4)

3. Remove the idler gear (3) from the idler hub (1).

4. Remove the thrust washer (2) from the idler hub (1).

5. Inspect all the components for wear or damage. If any components are worn or damaged, use new parts for replacement.

Note: Refer to Specifications, "Engine Oil Pump" for more information.

6. If the engine oil pump has excessive buildup of sludge, inspect the oil strainer. The oil strainer can be removed by using the following procedure:

- a. Remove the engine oil pan. Refer to Disassembly and Assembly, "Engine Oil Pan - Remove and Install".

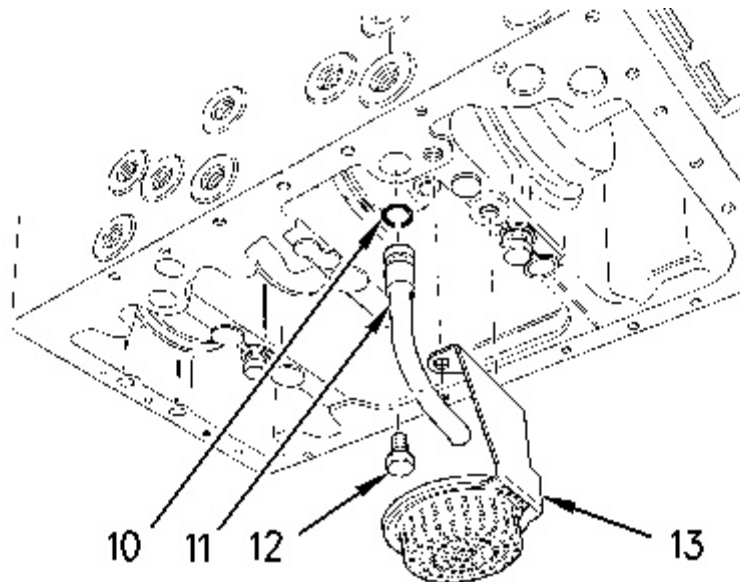

Illustration 2

g00825406

- b. Remove the setscrews (12) and the oil strainer (13) from the cylinder block. Inspect the oil strainer for damage. If the oil strainer is damaged, use a new part for replacement.

- c. Remove the oil tube (11) from the cylinder block.

- d. Remove the O-ring (10) from the oil tube. Discard the used O-ring.

Idler Hub

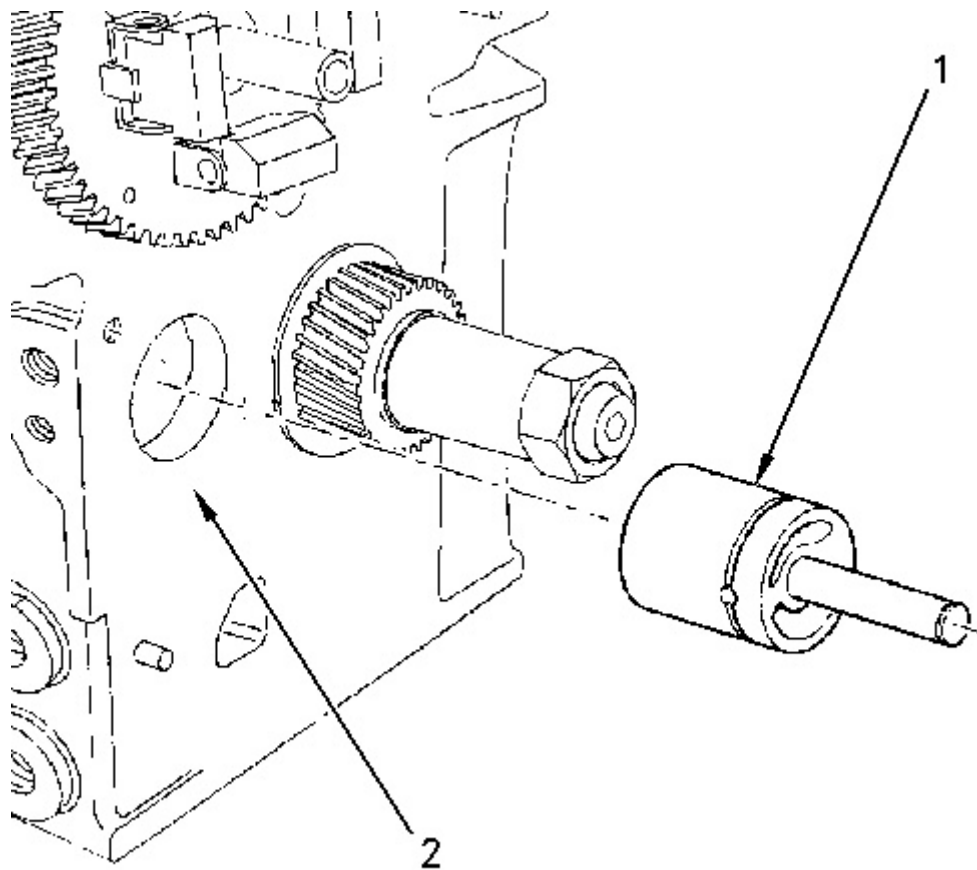

Illustration 3
Typical example

g00831103

1. Remove the crankshaft. Refer to Disassembly and Assembly, "Crankshaft - Remove".
 2. Use a hammer and use a suitable drift to remove idler hub (1) from the cylinder block (2). Align the drift to the rear face of the hub and drive the hub from the inside of the cylinder block outward.
-

<https://www.ebooklibonline.com>

Hello dear friend!

Thank you very much for reading.

Enter the link into your browser.

The full manual is available for immediate download.

<https://www.ebooklibonline.com>