

Product: COMPACTOR

Model: CB8 COMPACTOR JL4

Configuration: CB8 Asphalt Compactor JL400001-UP (MACHINE) POWERED BY C3.4B Engine

Disassembly and Assembly CB7 and CB8 Vibratory Asphalt Compactor Machine Systems

Media Number -M0078953-00

Publication Date -01/01/2017

Date Updated -26/01/2017

i06871302

Drum - Remove and Install - Solid Drum

SMCS - 6605-010

S/N - EL51-UP

S/N - JL41-UP

S/N - NLJ1-UP

Removal Procedure

Table 1

Required Tools			
Tool	Part Number	Part Description	Qty
A	-	Loctite 242	-
B	1U-6130	Guide Stud	2

Start By:

- a. Release system pressure.
- b. Engage steering frame lock.
- c. Remove front drum scraper.



WARNING

Personal injury can result from hydraulic oil pressure and hot oil.

Hydraulic oil pressure can remain in the hydraulic system after the engine has been stopped. Serious injury can be caused if this pressure is not released before any service is done on the hydraulic system.

Make sure all of the work tools have been lowered to the ground, and the oil is cool before removing any components or lines. Remove the oil filler cap only when the engine is stopped, and the filler cap is cool enough to touch with your bare hand.

1. Insure machine is on a flat level surface before drum is removed.



Illustration 1

g03004523



Illustration 2

g02992559

2. Use suitable lifting device and place vibratory compactor on suitable cribbing.
-

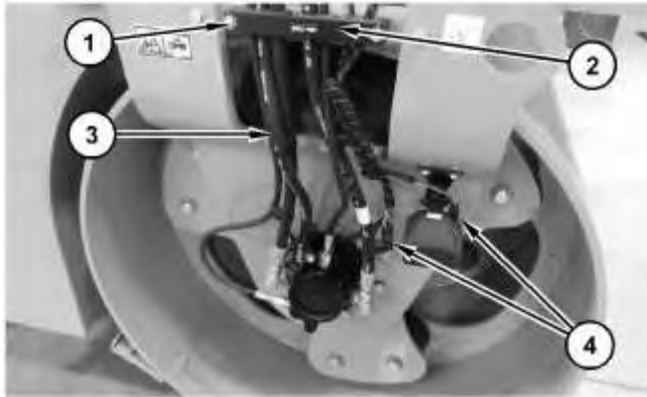

Illustration 3

g06148348

3. Disconnect five hose assemblies (3).
4. Disconnect two harness assemblies (4).
5. Remove two bolts (1), the four washers, the two nuts, and half clamp (2).

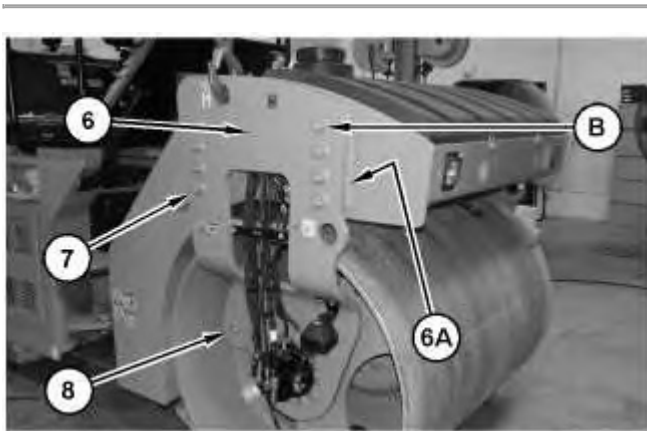

Illustration 4

g06148352

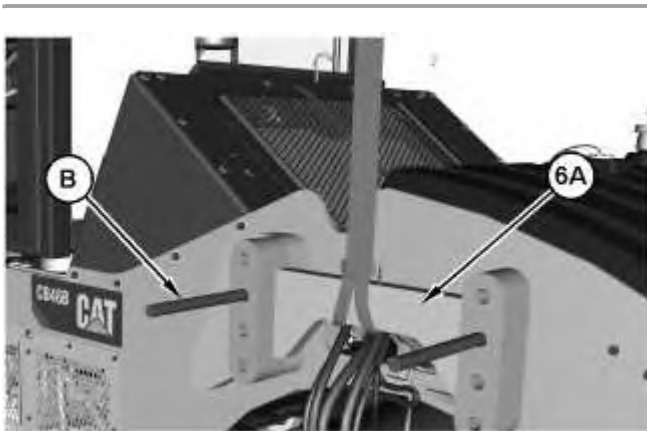

Illustration 5

g06061861

6. Attach a suitable lifting device to support assembly (6). The weight of support assembly (6) is approximately 200 kg (441 lb).

<https://www.ebooklibonline.com>

Hello dear friend!

Thank you very much for reading.

Enter the link into your browser.

The full manual is available for immediate download.

<https://www.ebooklibonline.com>

Note: If the machine is equipped with a wider drum, use Tooling (B) to support spacer (6A) during the removal of support assembly (6).

7. Remove eight bolts (7). Lower the drum assembly and support assembly (6) to the ground. Remove six bolts (8). Remove support assembly (6). If equipped, remove the spacer behind support assembly (6).

Note: If equipped, attach a suitable lifting device to spacer (6A). The weight of spacer (6A) is approximately 50 kg (110 lb). Remove spacer (6A) and remove Tooling (B).

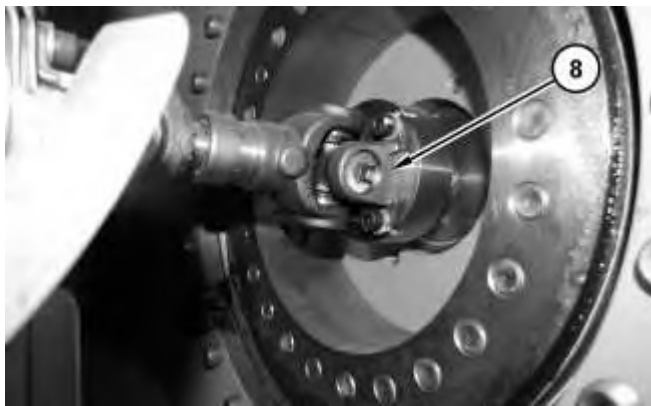

Illustration 6

g03004580

8. Remove the eight bolt, the eight washers, the fan assembly, and drive shaft (8).

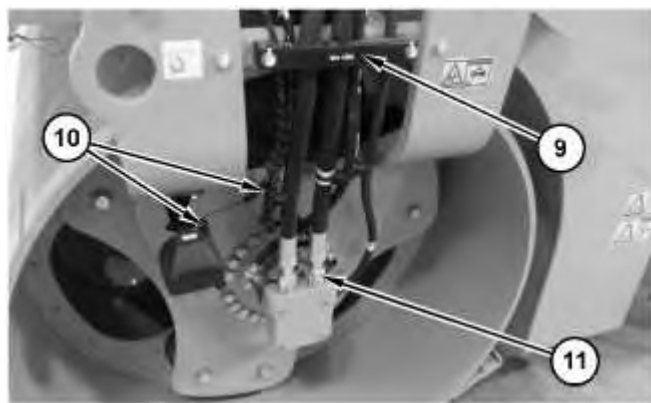

Illustration 7

g06148369

9. Remove the two bolts, the four washers, the two nuts, and half clamp (9).
 10. Disconnect two harness assemblies (10).
 11. Loosen the clamp and remove the hose.
 12. Disconnect hose assemblies (11).
-

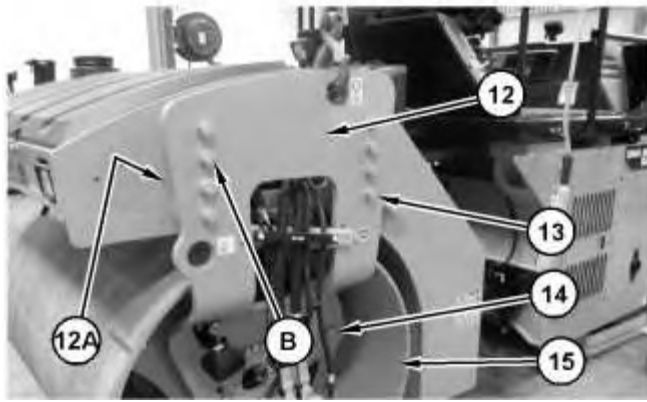

Illustration 8

g06061887

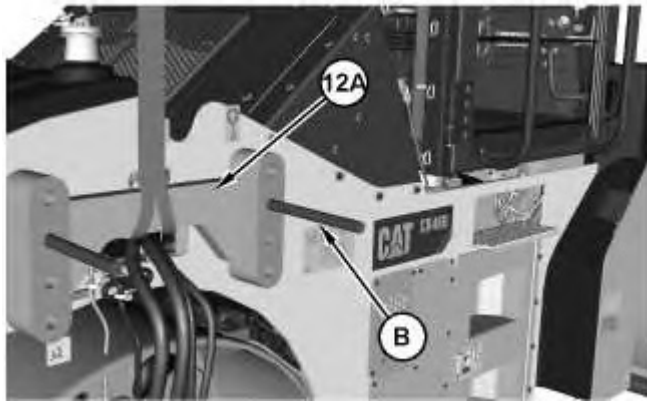

Illustration 9

g06061896

13. Attach a suitable lifting device to support assembly (12). The weight of support assembly (12) is approximately 320 kg (705 lb). Remove bolts (13). Lower bolts (13) and drum assembly (15) to the ground.

Note: If the machine is equipped with a wider drum, Use Tooling (B) to support spacer (12A) during the removal of support assembly (12).

14. Remove six bolts (14) and support assembly (12).

Note: If equipped, attach a suitable lifting device to spacer (12A). The weight of spacer (12A) is approximately 50 kg (110 lb). Remove spacer (12A) and remove Tooling (B).

15. Remove drum (15). Chock drum (15).

Installation Procedure

1. Install drum (15) in the reverse order of removal.
 - a. Apply Tooling (A) to six bolts (14).

Product: COMPACTOR

Model: CB8 COMPACTOR JL4

Configuration: CB8 Asphalt Compactor JL400001-UP (MACHINE) POWERED BY C3.4B Engine

Disassembly and Assembly CB7 and CB8 Vibratory Asphalt Compactor Machine Systems

Media Number -M0078953-00

Publication Date -01/01/2017

Date Updated -26/01/2017

i04785589

Drum Scraper - Remove and Install

SMCS - 6607-010

Removal Procedure

Start By:

- a. Connect the steering frame lock.



Illustration 1

g02894998

1. Attach a suitable lifting device to front scraper assembly (1). The weight of front scraper assembly (1) is approximately 68 kg (150 lb).
 2. Disconnect hose assembly (2).
-

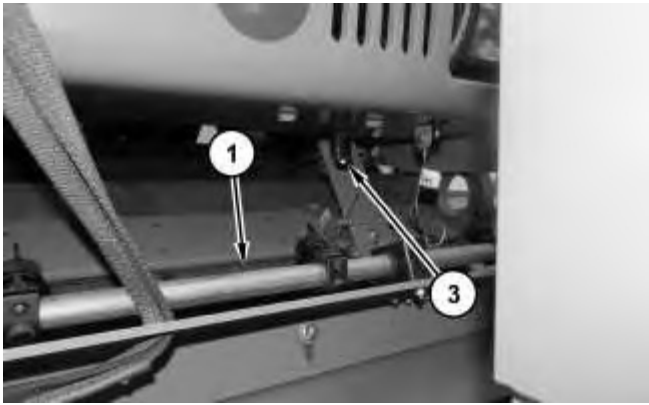

Illustration 2

g02895039

3. Remove bolts (3) and front scrapper assembly (1).

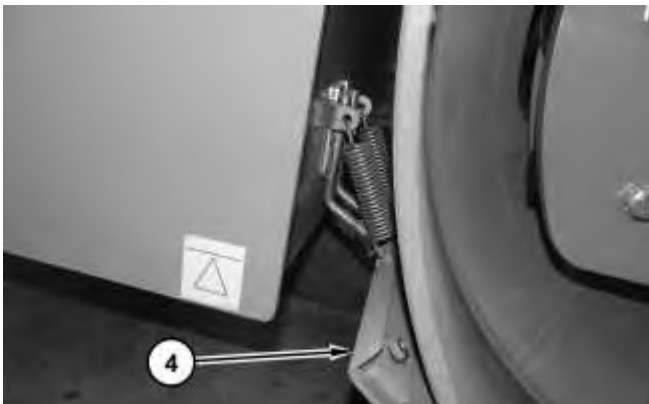

Illustration 3

g02895057

4. Use suitable cribbing for rear scrapper assembly (4).

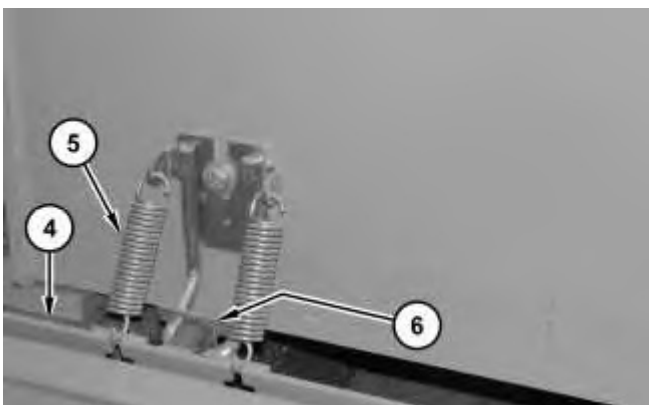

Illustration 4

g02895076

Note: For reference only.

5. Disconnect springs (5).

6. Remove bolts (6). Use two people in order to remove rear scrapper (4). The weight of rear scrapper assembly (4) is approximately 30 kg (66 lb).

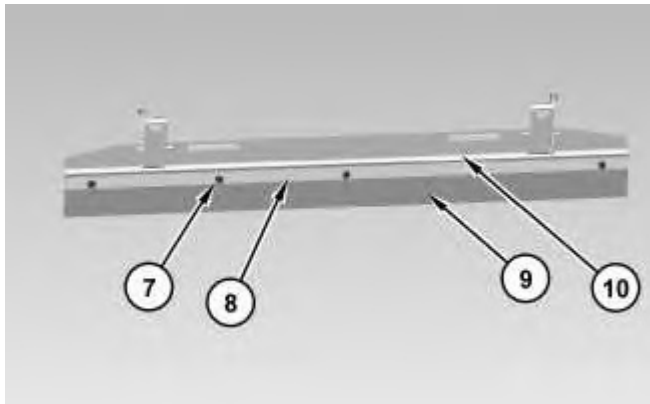

Illustration 5

g02895156

7. Remove bolts (7).
8. Remove plate (8) and scrapper (9) from support assembly (10).
9. Repeat Step 8 for rear scrapper (4).

Installation Procedure

1. Install front scrapper (1) and rear scrapper (4) in the reverse order of removal.
 - a. Tighten bolts (3) and (6) to a torque of 6 ± 1 N·m (53 ± 9 lb in).
 - b. Tighten bolts (10) to a torque of 15 ± 3 N·m (133 ± 27 lb in).
-

Product: COMPACTOR

Model: CB8 COMPACTOR JL4

Configuration: CB8 Asphalt Compactor JL400001-UP (MACHINE) POWERED BY C3.4B Engine

Disassembly and Assembly CB7 and CB8 Vibratory Asphalt Compactor Machine Systems

Media Number -M0078953-00

Publication Date -01/01/2017

Date Updated -26/01/2017

i04786341

Piston Motor (Drum Propel) - Remove and Install - Solid Drum

SMCS - 5058-010

Removal Procedure

Table 1

Required Tools			
Tool	Part Number	Part Description	Qty
A	-	Loctite 242	1

Start By:

- a. Release system pressure.
- b. Engage steering frame lock.



Personal injury can result from hydraulic oil pressure and hot oil.

Hydraulic oil pressure can remain in the hydraulic system after the engine has been stopped. Serious injury can be caused if this pressure is not released before any service is done on the hydraulic system.

Make sure all of the work tools have been lowered to the ground, and the oil is cool before removing any components or lines. Remove the oil filler cap only when the engine is stopped, and the filler cap is cool enough to touch with your bare hand.

1. Drain the hydraulic oil from the hydraulic tank into a suitable container for storage or disposal. Refer to Operation and Maintenance Manual for the correct procedure for the correct draining and filling procedures.



Illustration 1

g02897187

2. Raise machine and place on suitable cribbing.

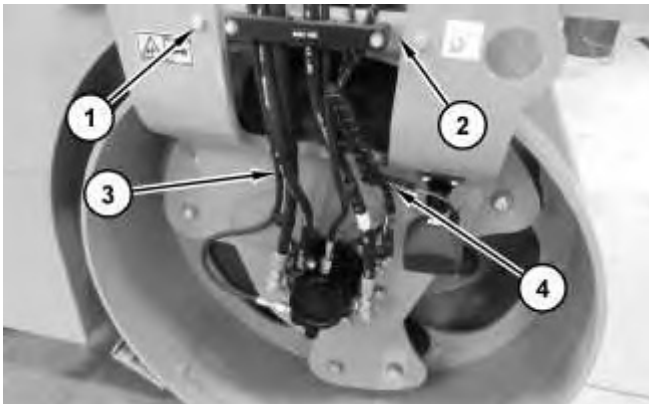

Illustration 2

g02896885

3. Disconnect hose assemblies (3).
 4. Disconnect harness assemblies (4).
 5. Remove bolts (1) and reposition plate assembly (2).
-



Illustration 3

g02897238

6. Remove bolts (5).



Illustration 4

g02897398

7. Attach a suitable lifting device to support assembly (6). The weight of support assembly (6) is approximately 200 kg (441 lb).
8. Remove bolts (7) and support assembly (6).

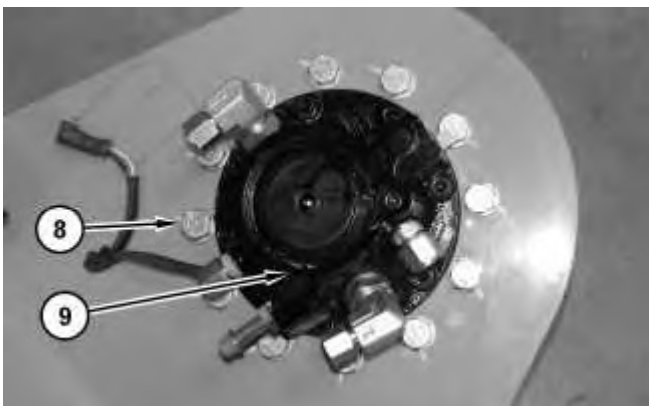

Illustration 5

g02897477

9. Remove bolts (8) and final drive motor assembly (9).

Installation Procedure

1. Install final drive motor assembly (2) in the reverse order of removal.
 - a. Apply Tooling (A) to bolts (8).
 - b. Tighten bolts (1) to a torque of $15 \pm 3 \text{ N}\cdot\text{m}$ ($133 \pm 27 \text{ lb in}$).
-

Product: COMPACTOR

Model: CB8 COMPACTOR JL4

Configuration: CB8 Asphalt Compactor JL400001-UP (MACHINE) POWERED BY C3.4B Engine

Disassembly and Assembly CB7 and CB8 Vibratory Asphalt Compactor Machine Systems

Media Number -M0078953-00

Publication Date -01/01/2017

Date Updated -26/01/2017

i04791251

Piston Motor (Drum Propel) - Remove and Install - Split Drum

SMCS - 5058-010

Removal Procedure

Start By:

- a. Release system pressure.



Personal injury can result from hydraulic oil pressure and hot oil.

Hydraulic oil pressure can remain in the hydraulic system after the engine has been stopped. Serious injury can be caused if this pressure is not released before any service is done on the hydraulic system.

Make sure all of the work tools have been lowered to the ground, and the oil is cool before removing any components or lines. Remove the oil filler cap only when the engine is stopped, and the filler cap is cool enough to touch with your bare hand.

-
1. Drain the hydraulic oil from the hydraulic tank into a suitable container for storage or disposal. Refer to Operation and Maintenance Manual for the correct procedure for the correct draining and filling procedures.
-

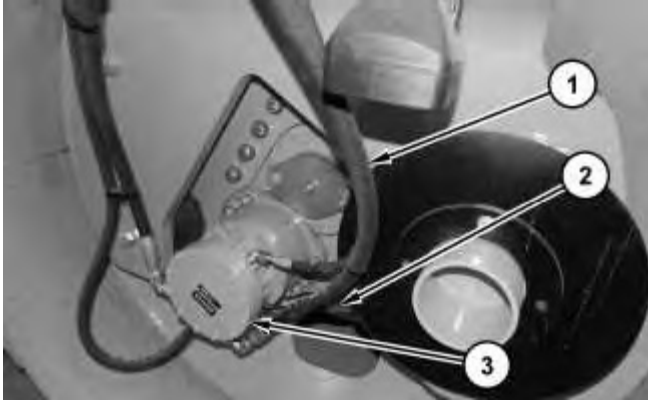

Illustration 1

g02908216

2. Disconnect hose assemblies (1) and harness assembly (2).
3. Remove piston motor (3). Use two people to remove piston motor (3). The weight of piston motor (3) is approximately 36 kg (80 lb).

Installation Procedure

1. Install piston motor (3) in the reverse order of removal.
-

Product: COMPACTOR

Model: CB8 COMPACTOR JL4

Configuration: CB8 Asphalt Compactor JL400001-UP (MACHINE) POWERED BY C3.4B Engine

Disassembly and Assembly CB7 and CB8 Vibratory Asphalt Compactor Machine Systems

Media Number -M0078953-00

Publication Date -01/01/2017

Date Updated -26/01/2017

i04791068

Piston Motor (Vibratory) - Remove and Install - Split Drum

SMCS - 5058-010; 5651-010

Removal Procedure

Table 1

Required Tools			
Tool	Part Number	Part Description	Qty
A	-	Loctite 242	-

Start By:

- a. Release system pressure.



WARNING

Personal injury can result from hydraulic oil pressure and hot oil.

Hydraulic oil pressure can remain in the hydraulic system after the engine has been stopped. Serious injury can be caused if this pressure is not released before any service is done on the hydraulic system.

Make sure all of the work tools have been lowered to the ground, and the oil is cool before removing any components or lines. Remove the oil filler cap only when the engine is stopped, and the filler cap is cool enough to touch with your bare hand.

1. Drain the hydraulic oil from the hydraulic tank into a suitable container for storage or disposal. Refer to Operation and Maintenance Manual for the correct procedure for the correct draining and filling procedures.

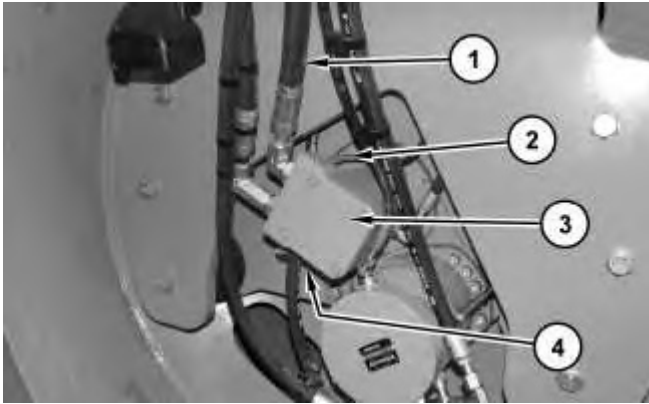

Illustration 1

g02907798

2. Disconnect hose assemblies (1) and harness assembly (2). Remove bolts (4) and piston motor (vibratory) (3).

Installation Procedure

1. Install piston motor (vibratory) (3) in the reverse order of removal.
 - a. Apply Tooling (A) to bolts (4).

Note: Apply lubricant to splines and add 10 mL (0.34 oz) of lubricant to shaft cavity.



Suggest:

For more complete manuals. Please go to the home page.

<https://www.ebooklibonline.com>

If the above button click is invalid. Please download this document first, and then click the above link to download the complete manual.

Thank you so much for reading

Product: COMPACTOR

Model: CB8 COMPACTOR JL4

Configuration: CB8 Asphalt Compactor JL400001-UP (MACHINE) POWERED BY C3.4B Engine

Disassembly and Assembly CB7 and CB8 Vibratory Asphalt Compactor Machine Systems

Media Number -M0078953-00

Publication Date -01/01/2017

Date Updated -26/01/2017

i06870367

Piston Motor (Vibratory) - Remove and Install - Solid Drum

SMCS - 5058-010; 5651-010

Removal Procedure

Table 1

Required Tools			
Tool	Part Number	Part Description	Qty
A	-	Loctite 242	1

Start By:

- a. Release system pressure.



WARNING

Personal injury can result from hydraulic oil pressure and hot oil.

Hydraulic oil pressure can remain in the hydraulic system after the engine has been stopped. Serious injury can be caused if this pressure is not released before any service is done on the hydraulic system.

Make sure all of the work tools have been lowered to the ground, and the oil is cool before removing any components or lines. Remove the oil filler cap only when the engine is stopped, and the filler cap is cool enough to touch with your bare hand.

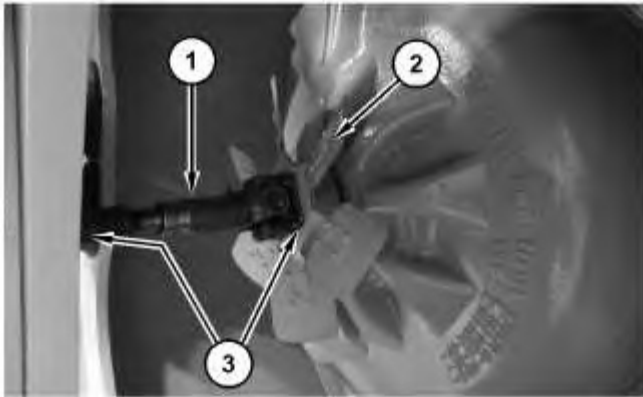

Illustration 1

g06147575

1. Remove eight bolts (3), the eight washers, shaft assembly (1), and fan assembly (2)

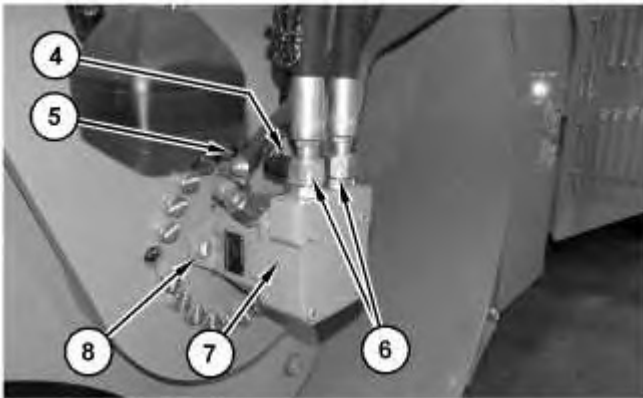

Illustration 2

g06147582

2. Disconnect harness assembly (4).
3. Loosen the clamp and remove hose (5).
4. Disconnect two hose assemblies (6).
5. Remove two bolts (8), the two washers, and piston motor (7).

Installation Procedure

1. Install piston motor (7) in the reverse order of removal.
 - a. Apply Tooling (A) to eight bolts (3).

<https://www.ebooklibonline.com>

Hello dear friend!

Thank you very much for reading.

Enter the link into your browser.

The full manual is available for immediate download.

<https://www.ebooklibonline.com>