

# OPERATOR'S MANUAL

## CARTED RAKE

| WR3008

| WR3010

| WR3012



HSMFG0908



**Suggest:**

**For more complete manuals. Please go to the home page.**

**<https://www.ebooklibonline.com>**

**If the above button click is invalid. Please download this document first, and then click the above link to download the complete manual.**

**Thank you so much for reading**

# TABLE OF CONTENTS

|   |              |
|---|--------------|
| TABLE OF CONTENTS.....                              | INSIDE COVER |
| WARRANTY & WARRANTY STATEMENT.....                  | 1            |
| DEALER PRE-DELIVERY & DELIVERY CHECKLIST.....       | 3            |
| SPECIFICATIONS.....                                 | 5            |
| BOLT TORQUE CHART.....                              | 6            |
| BE ALERT SYMBOL.....                                | 7            |
| SAFETY RULES.....                                   | 8-9          |
| DANGER - WARNING DECALS.....                        | 10           |
| OPERATION WR3008, WR3010 & WR3012.....              | 11-12        |
| ADJUSTMENTS.....                                    | 13-14        |
| OPTIONAL CENTER KICKER WHEEL.....                   | 15           |
| LUBRICATION WR3008, WR3010 & WR3012.....            | 16           |
| DECAL LOCATION.....                                 | 17           |
| TROUBLE SHOOTING.....                               | 18           |
| ORDERING PARTS - ABOUT IMPROVEMENTS.....            | 19           |
| PARTS LISTS & DIAGRAMS WR3008, WR3010 & WR3012..... | 20-27        |
| SERVICE RECORDS.....                                | 28           |

**<https://www.ebooklibonline.com>**

Hello dear friend!

Thank you very much for reading.

Enter the link into your browser.

The full manual is available for immediate download.

**<https://www.ebooklibonline.com>**

# FRONTIER WR3008, WR3010, WR3012 CARTED RAKE

Your new Frontier Carted Rake has been manufactured of the finest quality materials and components. The performance you get from your machine is largely dependent upon how well you read and understand this manual and apply this knowledge. There is a right and a wrong way to do everything. Please do not assume that you know how to operate and maintain your Heavy Duty Wheel Rake before reading this manual carefully. Keep this manual available for ready reference.

## SPECIFICATIONS

|                                 | WR3008          | WR3010                | WR3012     |
|---------------------------------|-----------------|-----------------------|------------|
| Number of Wheels.....           | 8.....          | 10.....               | 12         |
| Wheel Diameter.....             | 55".....        | 55".....              | 55"        |
| Teeth per Wheel.....            | 40.....         | 40.....               | 40         |
| Tooth Diameter.....             | 7mm.....        | 7mm.....              | 7mm        |
| Transport Width.....            | 9'6".....       | 9'6".....             | 10'6"      |
| Transport Length.....           | 13'.....        | 15'6".....            | 18'        |
| Windrow Width Adjustment.....   | 4'-6'.....      | 4'-6'.....            | 4'-6'      |
| Raking Width.....               | 16'-20'.....    | 18'-22'.....          | 20'-24'    |
|                                 | 3 Settings..... | 3 Settings.....       | 3 Settings |
| Weight.....                     | 1125 lbs.....   | 1275 lbs.....         | 1440 lbs.  |
| Number of Transport Wheels..... | 2.....          | 2.....                | 2          |
| Center Kicker Wheel.....        | N/A.....        | Optional.....         | Optional   |
| Rake Wheel Hubs.....            |                 | Tapered Bearings..... |            |
| Wing Flex.....                  |                 | Limited.....          |            |
| Hitch Jack.....                 |                 | Standard.....         |            |
| Tires.....                      |                 | ST175/80D13.....      |            |

**NOTE:**

Determine right or left side of Carted Rake by viewing it from the rear. If instructions or parts lists call for hardened bolts see page 6 to identify.

# CAP SCREW TORQUE VALUES

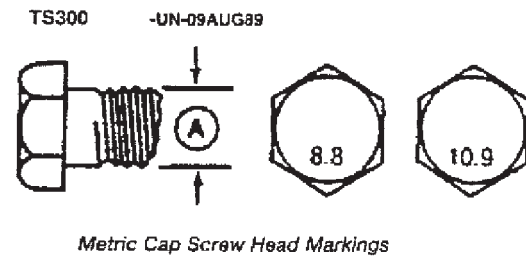
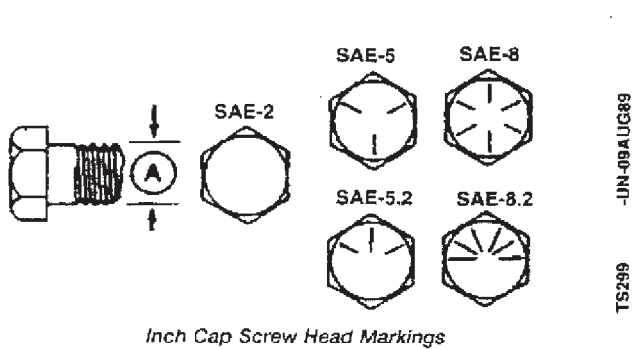

## INCH CAP SCREW TORQUE VALUES

## METRIC CAP SCREW TORQUE VALUES

| Bolt Diameter<br>(A) | Wrench Size | Cap Screw Grade |        |       |        |       |        |
|----------------------|-------------|-----------------|--------|-------|--------|-------|--------|
|                      |             | SAE 2           |        | SAE 5 |        | SAE 8 |        |
|                      |             | N-m             | lb.-ft | N-m   | lb.-ft | N-m   | lb.-ft |
| 1/4"                 | 7/16"       | 7               | (5)    | 11    | (8)    | 16    | (12)   |
| 5/16"                | 1/2"        | 14              | (10)   | 23    | (17)   | 33    | (24)   |
| 3/8"                 | 9/16"       | 24              | (18)   | 41    | (30)   | 54    | (40)   |
| 7/16"                | 5/8"        | 41              | (30)   | 68    | (50)   | 95    | (70)   |
| 1/2"                 | 3/4"        | 61              | (45)   | 102   | (75)   | 142   | (105)  |
| 9/16"                | 13/16"      | 88              | (65)   | 142   | (105)  | 203   | (150)  |
| 5/8"                 | 15/16"      | 122             | (90)   | 197   | (145)  | 278   | (205)  |
| 3/4"                 | 1-1/8"      | 217             | (160)  | 353   | (260)  | 495   | (365)  |
| 7/8"                 | 1-5/16"     | 224             | (165)  | 563   | (415)  | 800   | (590)  |
| 1"                   | 1-1/2"      | 332             | (245)  | 848   | (625)  | 1193  | (880)  |
| 1-1/4"               | 1-7/8"      | 665             | (490)  | 1492  | (1100) | 2393  | (1765) |

| Bolt Diameter<br>(A) | Wrench Size | Markings on Cap Screw Heads |        |      |        |
|----------------------|-------------|-----------------------------|--------|------|--------|
|                      |             | 8.8                         |        | 10.9 |        |
|                      |             | N-m                         | lb.-ft | N-m  | lb.-ft |
| 5 mm                 | 8 mm        | 6                           | (4.5)  | 9    | (6.5)  |
| 6 mm                 | 10 mm       | 10                          | (7.5)  | 15   | (11)   |
| 8 mm                 | 13 mm       | 25                          | (18)   | 35   | (26)   |
| 10 mm                | 16 mm       | 50                          | (37)   | 75   | (55)   |
| 12 mm                | 18 mm       | 85                          | (63)   | 130  | (97)   |
| 16 mm                | 24 mm       | 215                         | (159)  | 315  | (232)  |
| 20 mm                | 30 mm       | 435                         | (321)  | 620  | (457)  |
| 24 mm                | 36 mm       | 750                         | (553)  | 1070 | (789)  |
| 30 mm                | 46 mm       | 1495                        | (1103) | 2130 | (1571) |



**CAUTION:** Use only metric tools on metric hardware. Other tools may not fit properly. They may slip and cause injury.

DO NOT use these values if a different torque value tightening procedure is listed for a specific application. Torque values listed are for general use only. Check tightness of cap screws periodically.

Shear bolts are designed to fail under predetermined loads. Always replace shear bolts with identical grade. Fasteners should be replaced with the same or higher grade. If higher grade fasteners are used, these should only be tightened to the strength of the original.

Make sure fastener threads are clean and you properly start thread engagement. This will prevent them from failing when tightening.

Tighten plastic insert or crimped steel-type lock nuts to approximately 50 percent of amount shown in chart. Tighten toothed or serrated-type lock nuts to full torque value.



**BE  
ALERT!**

**YOUR SAFETY  
IS INVOLVED.**

**THIS SYMBOL IS USED THROUGHOUT THIS BOOK WHENEVER YOUR PERSONAL SAFETY IS INVOLVED. TAKE TIME TO BE CAREFUL. REMEMBER: THE CAREFUL OPERATOR IS THE BEST OPERATOR. MOST ACCIDENTS ARE CAUSED BY HUMAN ERROR. CERTAIN PRECAUTIONS MUST BE OBSERVED TO PREVENT THE POSSIBILITY OF INJURY OR DAMAGE.**

**TRACTORS**

**This operator's manual uses the term "Tractor" when identifying the power source.**

## RECOGNIZE SAFETY INFORMATION

This is the safety-alert symbol. When you see this symbol on your machine or in this manual, be alert to the potential for personal injury.

Follow recommended precautions and safe operating practices.



## UNDERSTAND SIGNAL WORDS

A signal word- DANGER, WARNING, or CAUTION - is used with the safety-alert symbol. DANGER identifies the most serious hazards.

Safety signs with signal word DANGER or WARNING are typically near specific hazards.

General precautions are listed on CAUTION safety signs.



## FOLLOW SAFETY INSTRUCTIONS

Carefully read all safety messages in this manual, and all safety signs on your machine. Follow all recommended precautions and safe operating procedures.

Keep signs in good condition. Immediately replace any missing or damaged signs.



## OBSERVE MAXIMUM TRANSPORT SPEED

**The maximum transport speed for this implement is 32 km/h (20 mph).**

Some tractors are capable of operating at speeds that exceed the maximum transport speed of this implement. Regardless of the maximum speed capability of the tractor being used to tow this implement, do not exceed the implement's maximum transport speed.

Exceeding the implements maximum transport speed can result in:

- Loss of control of the tractor/implement combination
- Reduced or no ability to stop during braking
- Implement tire failure
- Damage to the implement structure or its components

Use additional caution and reduce speed when towing under adverse surface conditions, when turning, and when on inclines.

Do not attempt transport if the fully loaded implement weighs more than 1.5 times the weight of the tractor.



**<https://www.ebooklibonline.com>**

Hello dear friend!

Thank you very much for reading.

Enter the link into your browser.

The full manual is available for immediate download.

**<https://www.ebooklibonline.com>**